

73 TIME- AND MONEY-SAVING TIPS INSIDE

ISSUE 218 MAY 2013

Better Homes and Gardens®

WOOD

The World's Leading Woodworking Resource

Easy-to-Build Raised Planter

p.46

Win
\$5,000
of Jet Tools

p.6

The Easiest Mortise-and- Tenon Joint Ever

p.50

Tested & Rated: Whole-shop Dust Collectors

p.58

Safety Advice from the Wood Whisperer

p.22

Plus more great projects:

- ▶ First of a 5-piece set
Traditional Bed p.34
- ▶ Dual-duty Dust-collecting
Tool Stand p.28
- ▶ Build-in-a-weekend
Coat Rack p.24
- ▶ Zero-footprint
Sofa Server p.42
- ▶ Try timber framing with this first-class
Mailbox Post p.54

Protect Your Shop with a Digital Inventory

p.16

Display until May 7, 2013



\$6.99 U.S.

0 925671 14072 5



Grizzly Industrial

PURVEYORS OF FINE MACHINERY®, SINCE 1983!

- OVER A MILLION SQUARE FEET PACKED TO THE RAFTERS WITH MACHINERY & TOOLS
- 2 OVERSEAS QUALITY CONTROL OFFICES STAFFED WITH QUALIFIED GRIZZLY ENGINEERS
- HUGE PARTS FACILITY WITH OVER 1 MILLION PARTS IN STOCK AT ALL TIMES
- TRAINED SERVICE TECHNICIANS AT ALL 3 LOCATIONS • MOST ORDERS SHIP THE SAME DAY



10" CONTRACTOR TABLE SAWS With Riving Knife

- Motor: 1½ HP or 2HP, 110V/220V, single-phase
- Precision-ground cast iron table wings: 27"D x 44"W
- Arbor: ¾"
- Arbor speed: 4200 RPM
- Table height: 35½"
- Footprint: 26"W x 26¼"D
- Capacity: 3½" @ 90°, 2¼" @ 45°
- Rip capacity: 36" R, 12" L
- Approx. shipping weight: 328 lbs. (G0713) 338 lbs. (G0661)



1-3/4 HP, LEFT-TILTING, SINGLE-PHASE

G0713 ONLY \$895⁰⁰

2 HP, LEFT-TILTING SINGLE-PHASE

G0661 ONLY \$925⁰⁰



10" HYBRID TABLE SAW With Riving Knife

- Motor: 2 HP, 110V/220V, single-phase
- Precision-ground cast iron table size w/ wings : 27" x 40" • Arbor: ¾"
- Arbor speed: 3850 RPM
- Capacity: 3¾" @ 90°, 2½" @ 45°
- Rip capacity: 12" L, 30" R
- Cast iron trunnions
- Approx. shipping weight: 404 lbs.



BEAUTIFUL
WHITE COLOR!

INCLUDES BOTH REGULAR
& DADO BLADE INSERTS



G0715P ONLY \$795⁰⁰



12" BABY DRUM SANDERS

- Sanding motor: 1½ HP, 110V, single-phase
- Conveyor motor: ¼ HP, 110V, single-phase, variable speed 5-35 FPM
- Max. stock thickness: 3½"
- Min. stock length: 8"
- Sanding drum size: 4"
- Sanding belt: 3" x 70" hook & loop
- Dust collection port: 2½"
- Approx. shipping weight: 160 lbs.



MADE IN TAIWAN



CLASSIC GRIZZLY GREEN COLOR

G0459 ONLY \$595⁰⁰

POLAR BEAR® DAZZLING WHITE COLOR

G0459P ONLY \$595⁰⁰



8" JOINTERS

- Motor: 3 HP, 220V, single-phase, TEFC
- Precision-ground cast iron table size: 9" x 72½"
- Max. depth of cut: ¼"
- Max. rabbeting depth: ½"
- Cutterhead dia.: 3"
- Cutterhead speed: 5000 RPM (G0656P) 5350 RPM (G0656PX)
- Cuts per minute: 20,000 (G0656P) 21,400 (G0656PX)
- Approx. shipping weight: 500 lbs.



FREE SAFETY
PUSH BLOCKS
BUILT-IN
MOBILE BASE

WITH 4 KNIFE CUTTERHEAD
G0656P ONLY \$825⁰⁰

WITH SPIRAL CUTTERHEAD
G0656PX ONLY \$1225⁰⁰



15" PLANERS

- Motor: 3 HP, 220V, single-phase
- Precision-ground cast iron table size: 15" x 20"
- Min. stock thickness: ¾"
- Min. stock length: 8"
- Max. cutting depth: ¼"
- Feed rate: 16 FPM & 30 FPM
- Cutterhead speed: 5000 RPM
- Approx. shipping weight: 662 lbs. (G0453P) 666 lbs. (G0453PX)



BUILT-IN
MOBILE BASE

WITH 3 KNIFE CUTTERHEAD
G0453P ONLY \$1095⁰⁰

WITH SPIRAL CUTTERHEAD
G0453PX ONLY \$1695⁰⁰



20" PLANER

- Motor: 5 HP, 240V, single-phase
- Max. cutting width: 20"
- Max. cutting height: 8"
- Min. stock thickness: ¾"
- Min. stock length: 8"
- Max. cutting depth: ½"
- Feed rate: 16 FPM & 20 FPM
- Cutterhead diameter: 3½"
- Cutterhead speed: 4800 RPM
- Feed rolls: solid serrated steel
- Overall dimensions: 55½"L x 39½"W x 45¼"H
- Approx. shipping weight: 920 lbs.



BUILT-IN
MOBILE BASE

G0454 ONLY \$1650⁰⁰



14" DELUXE BANDSAW

- Motor: 1 HP, TEFC, 110V/220V, single-phase (prewired 110V)
- Amps: 11 at 110V, 5.5 at 220V
- Blade size: 93½" long (½" - ¾" wide)
- Cutting cap/throat: 13½"
- Max. cutting height: 6"
- Overall size: 67½"H x 27"W x 30"D
- Footprint: 23½" x 16½"
- Table height above floor: 43"
- Table tilt: 45° right, 10° left
- Approx. shipping weight: 246 lbs.



Cast Iron
Wheels

G0555LX ONLY \$545⁰⁰



14" BANDSAW

- Motor: 1 HP, TEFC, 110V / 220V single-phase, 1725 RPM
- 4" dust port
- Cutting capacity/throat: 13½"
- Max. cutting height: 6"
- Overall size: 66½"H x 26½"W x 30¼"D
- Precision-ground cast iron table size 14" x 14"
- Table height: 43½"
- Tilt: 45° R, 10° L
- Fence construction: Deluxe extruded aluminum
- Blade speeds: 1500 & 3200 FPM
- Blade size: 92½" - 93½" (½" to ¾" wide)
- Approx. shipping weight: 196 lbs.



SA
252003
LIMITED SUPPLIES

G0555P ONLY \$525⁰⁰



2 HP DUST COLLECTOR With Aluminum Impeller

- Motor: 2 HP, 240V, single-phase, 9A, 3450 RPM
- Air suction capacity: 1550 CFM
- Max. static pressure: 11"
- Bag capacity: 5.7 cu. ft.
- Impeller: 12¼" balanced steel, radial fin
- Height w/ bags inflated 78"
- Portable base: 21¼" x 33½"
- Approx. shipping weight: 122 lbs.



SA
247570

G1029Z2P ONLY \$325⁰⁰



PRICING CODE

13WOODM
MENTION THIS CODE
WHEN PLACING YOUR ORDER

15460R

1-800-523-4777 grizzly.com

TECHNICAL SERVICE: 570-546-9663 FAX: 800-438-5901

3 GREAT SHOWROOMS! BELLINGHAM, WA • MUNCY, PA • SPRINGFIELD, MO



FREE CATALOG
764 PAGES
HUGE SELECTION OF
HIGH QUALITY
MACHINES & TOOLS
AT INCREDIBLE PRICES

In this issue



24



34

PROJECTS

- 20 **Shop Helper: Pipe-clamp Risers**
- 24 **Weekend Project: Coat and Hat Hanger**
- 28 **Dust-collecting Tool Stand**
No need to drag a dust collector to your tools; it's built right into this handy stand.
- 34 **Traditional Bed**
The first of a fabulous five-piece bedroom suite.
- 42 **Sofa Server**
- 46 **Raised Planter Box**
Stand tall when you weed or harvest plantings.
- 54 **Timber-frame Mailbox**
Learn old-school methods using contemporary tools.

TOOLS & TECHNIQUES

- 16 **Protect Yourself with a Shop Inventory**
- 50 **Simple and Strong: Loose-tenon Joinery**
Learn this method and you may never make mortise-and-tenon joints any other way.
- 58 **SHOP TEST: Dust Collectors**
These models pack enough punch to pull a small-shop central system.
- 72 **Shop-Proven Products**
Three top drill/countersink sets, lightweight circular saw, and more.



54

DEPARTMENTS

- 3 **Editor's Angle**
- 4 **Sounding Board**
- 6 **Shop Tips**
- 22 **Unvarnished**
Shop-safety lessons from a baby boy
- 66 **Ask WOOD®**
- 84 **What's Ahead**



The **WOOD®** magazine difference:
We build every project, verify every fact, and test every reviewed tool in our workshop to guarantee your success and complete satisfaction.



58



28



42

On our website
woodmagazine.com

IT'S ALL ABOUT SAVING TIME

Forget about sleep; with the switch to Daylight Saving Time, most of us lose a precious hour of shop time! That makes these free tips even more valuable this time of the year:

- **Glue-up tricks**
woodmagazine.com/gluetips
- **When to skip the sealer**
woodmagazine.com/sandingsealer
- **Fit joints faster**
woodmagazine.com/jointtools
- **One-setup half-lap jig**
woodmagazine.com/easyhalflaps
- **Timely tips delivered daily**
woodmagazine.com/tips



JOIN THE GUILD, GET A FREE DVD, EXPERT VIDEOS, AND MORE!

Our partnership with WoodWorkers Guild of America brings you expert woodworking videos viewable any time, anywhere, on your computer, tablet, or smartphone. Upgrade to a premium membership and you'll have unlimited access to:

- ▶ exclusive tip and technique videos
- ▶ DVD-length woodworking how-to videos
- ▶ 10% member discount at the WOOD Store
- ▶ hundreds of online articles, and more!

Sign up for a premium membership at go.wwgoa.com/freedvd before May 21, 2013, and we'll give you the DVD shown plus \$10 off your next purchase at the WOOD Store.



WOODWORKERS
GUILD OF AMERICA
presented by
WOOD
Magazine

QUESTIONS ASKED, QUESTIONS ANSWERED

Share your shop-won wisdom with other woodworkers—or post a puzzler for the community to solve—when you visit **Ask WOOD® Online** at woodmagazine.com/askwood. Remember, it takes a village to grow great woodworkers, so stop by and help a brother out.

Ask **WOOD**
Online

Questions and answers from the woodworking community

Presented by



Better Homes and Gardens®
WOOD

May 2013

Vol. 30, No. 2

Issue No. 218

EDITORIAL CONTENT CHIEF **DAVE CAMPBELL**

DEPUTY EDITOR **CRAIG RUEGSEGGER**

ART DIRECTOR **KARL EHLERS**

DIGITAL CONTENT MANAGER **LUCAS PETERS**

SENIOR DESIGN EDITOR **KEVIN BOYLE**

DESIGN EDITOR **JOHN OLSON**

TOOLS EDITOR **BOB HUNTER**

GENERAL-INTEREST EDITOR **NATE GRANZOW**

ADMINISTRATIVE ASSISTANT **SHERYL MUNYON**

CONTRIBUTING CRAFTSMEN **JIM HEAVEY, ERV ROBERTS, BRIAN SIMMONS, BOB BAKER, TOM BRUMBACK, BOB SAUNDERS, STEVE FEENEY, MATT SEILER, DEAN FIENE, DOUG LEY**
PHOTOGRAPHERS **DEAN SCHOEPFNER, JASON DONNELLY, JAY WILDE**
CONTRIBUTING ILLUSTRATORS **TIM CAHILL, LORNA JOHNSON**
PROOFREADERS **BABS KLEIN, IRA LACHER, STEPHANIE RIVA, JIM SANDERS**

ADVERTISING AND MARKETING

VICE PRESIDENT/GROUP PUBLISHER **TOM DAVIS**
DIRECT RESPONSE ADVERTISING REPRESENTATIVE **LISA GREENWOOD 312-853-1225**
ONLINE MEDIA KIT woodmagazine.com/mediakit

BUSINESS MANAGER **DARREN TOLLEFSON** CONSUMER MARKETING DIRECTOR **LIZ BREDSON**
CONSUMER MARKETING MANAGER **BILL WOOD** RETAIL BRAND MANAGER-NEWSSTAND **JESS LIDDLE**
PRODUCTION MANAGER **SANDY WILLIAMS** ADVERTISING OPERATIONS MANAGER **JIM NELSON**

MEREDITH NATIONAL MEDIA GROUP

PRESIDENT **TOM HARTY**

EXECUTIVE VICE PRESIDENTS

PRESIDENT, MEDIA SALES **RICHARD PORTER** PRESIDENT, BETTER HOMES AND GARDENS **JAMES CARR**
PRESIDENT, PARENTS NETWORK **CAREY WITMER** PRESIDENT, WOMEN'S LIFESTYLE **THOMAS WITSCHI**
CREATIVE CONTENT LEADER **GAYLE GOODSON BUTLER** CHIEF MARKETING OFFICER **NANCY WEBER**
CHIEF DIGITAL OFFICER **LIZ SCHIMMEL** CHIEF REVENUE OFFICER **MICHAEL BROWNSTEIN**
CHIEF INNOVATION OFFICER **JEANNINE SHAO COLLINS** GENERAL MANAGER **MIKE RIGGS**
DIRECTOR, OPERATIONS & BUSINESS DEVELOPMENT **DOUG OLSON**

SENIOR VICE PRESIDENTS

CHIEF TECHNOLOGY OFFICER **JACK GOLDENBERG**
AUDIENCE DEVELOPMENT AND COMMERCE **ANDY WILSON** DIGITAL SALES **CAROLYN BEKEDAH**

VICE PRESIDENTS

CONSUMER MARKETING **JANET DONNELLY** CORPORATE MARKETING **STEPHANIE CONNOLLY**
CORPORATE SALES **BRIAN NIGHTLINGER** DIRECT MEDIA **PATTI FOLLO**
RESEARCH SOLUTIONS **BRITTA WARE** COMMUNICATIONS **PATRICK TAYLOR** NEWSSTAND **MARK PETERSON**

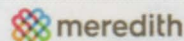

CHAIRMAN AND CHIEF EXECUTIVE OFFICER **STEPHEN M. LACY**
PRESIDENT, MEREDITH LOCAL MEDIA GROUP **PAUL KARPOWICZ**

VICE CHAIRMAN **MELL MEREDITH FRAZIER**
IN MEMORIAM — E.T. MEREDITH III (1933-2003)

HOW TO REACH US

- ▶ **For woodworking advice:** Post your woodworking questions (joinery, finishing, tools, turning, dust collection, etc.) on one of our online forums at woodmagazine.com/forums.
- ▶ **To contact our editors:** E-mail woodmail@woodmagazine.com; post on our Facebook at facebook.com/woodmagazine, or write to WOOD magazine, 1716 Locust St., LS-221, Des Moines, IA 50309.
- ▶ **Subscription assistance:** To contact us about your WOOD subscription, visit woodmagazine.com/help; e-mail wdmcustserv@cdsfulfillment.com; call 800-374-9663, option 1; or write to WOOD, PO Box 37508, Boone, IA 50037. Include your name and address as it appears on the magazine label, renewal notice, or invoice. For digital subscriptions, visit woodmagazine.com/zinio.
- ▶ **To find past articles:** Search our online article index at woodmagazine.com/index.
- ▶ **To order past issues and articles:** For past issues of WOOD magazine in print or on DVD-ROM, our newsstand-only issues, or downloadable articles, visit woodmagazine.com/store.
- ▶ **Updates to previously published projects:** For an up-to-date listing of changes in dimensions and buying-guide sources from issue 1 through today, go to woodmagazine.com/editorial.

Our subscribers list is occasionally made available to carefully selected firms whose products may be of interest to you. If you prefer not to receive information from these companies by mail or by phone, please let us know. Send your request along with your mailing label to Magazine Customer Service, PO Box 37508, Boone, IA 50037.

© Copyright Meredith Corporation 2013. All rights reserved. Printed in the U.S.A.
Retail Sales: Retailers can order copies of WOOD for resale by e-mailing jennifer.buser@meredith.com



Editor's Angle

Winter '13 post script

After Winter Storm Draco blasted across the U.S. late last year (we're naming snowstorms now?), I noticed my mailbox at the curb tilting at an awkward angle. It seems that 12" of slushy snow, when propelled by the blade of a snowplow, possesses enough force to snap a 4x4 mailbox post like a fresh garden-grown green bean.

It saddened me a bit because the little wooden house surrounding the steel mailbox, *below*, was a project I did with my now college-age son, Colby, back in his Cub Scout days. (And because it meant adding "replace mailbox" to my already too long honey-do list.)

But there are no problems, only opportunities, so the next time Colby heads home for a few days, we're planning to hit the shop to build a new mailbox, just like we did umpteen years ago. I'm thinking the timber-frame mailbox on *page 54* looks like a suitable (and more sturdy) replacement.

Make your bed. On *page 34* of this issue, you'll find complete plans for a traditional bed, the first of a five-piece suite that we'll be sharing with you over the next few issues. The set also includes a dresser, nightstand, lingerie chest, and a blanket chest. Design Editor John Olson built them all from affordable poplar, and customized the stain to mimic the rich look of cherry. Don't worry, we'll share John's finishing formula with you.

Speaking of sharing, whenever you complete a project, how about snapping a quick photo? Then post it on our Facebook ([facebook.com/woodmagazine](https://www.facebook.com/woodmagazine)) or gallery ([woodmagazine.com/gallery](https://www.woodmagazine.com/gallery)), or e-mail it to me. I'd love to see your work. 🌲

See you in the shop!



Dave Campbell
dave.campbell@meredith.com

Photo: Colby Campbell

GUHDO®

Advanced Technology Saw Blades



Precision Balanced



Perfect straightness



Superior grinding



Noise reduction



Maximum Life

Electrostatic Coating



Reduces friction



Protects against corrosion



Prevents resin build-up



Maximum Performance



The new GMAXX series from GUHDO

100 years of German Tooling
Innovation

www.guhdo-gmaxx.com

Holy woodworking projects!

Reader "altars" *WOOD* magazine's seating bench plan

When asked to make new altars for my church, I quickly found a plan I could modify to fit the task perfectly—the seating bench in issue 212 (July 2012) of *WOOD* magazine. To keep the eye-pleasing proportions while changing this seating into "standing," I scaled up the plans by 30 percent, made the end panels from 1"-thick oak instead of 3/4", added a blind mortise to the stretcher joints, and covered the screw heads in the end panel with an inlaid cherry cross instead of plugs.

—Joseph Sanger, St. Louis

You can download the seating bench plan for a small fee at woodmagazine.com/seatingbench.

—WOOD Editors



Monks put *WOOD* jigs to use

For years, *WOOD* magazine has exchanged friendly letters with the monks at Saint Gregory Palamas Monastery in Etna, California. Despite belonging to a cloistered monastery and being very private, they've occasionally shared photos of their woodworking projects, including this iconostasis, which they built for a small parish near San Diego. (An iconostasis, or *templon*, is a screen with icons attached to it, separating the altar from the nave—or central part—of the church. In the Orthodox Church, it symbolizes the border between the spiritual realm and the world as we know it.) We found it so stunning, we asked the monks if we could share it with our readers, and they agreed. The monks used *WOOD*'s fluting jig (November 2008, issue 187), hinge-mortising jig (April 2001, issue 132), and fairing stick (June/July 2003, issue 149) during the building process.



The monks built the iconostasis from MDF with wood inserts at the door-hinge locations, stained it, and applied several coats of water-based varnish to give it a high gloss.

When buying supplies, keep it local

I read with interest your article "Tips and Tricks from One-Man Pro Shops", issue 215 (November 2012). Although I picked up some good pointers for my small shop, I was dismayed to read Matt Seiler's suggestion to buy supplies and tools on the Internet.

Your neighborhood lumberyard, hardware store, and home center all support the local infrastructure and rely on the support of their customers to keep their doors open. And, unlike most websites, they have personnel on hand to answer your questions and help you find what you need.

—Rick Roehl, Montpelier, Ohio

Bandsaw bites the bullet

While resawing a log from an elm tree I'd cut down, my bandsaw began acting up, wavering and straying from the straight line it'd been cutting. A quick check showed that everything was still adjusted correctly on the saw. But a closer inspection of the workpiece revealed something I never would have expected to find: a copper-jacketed .45-caliber bullet cut almost through its exact center. 🌲

—Gary Sadoris, West Des Moines, Iowa

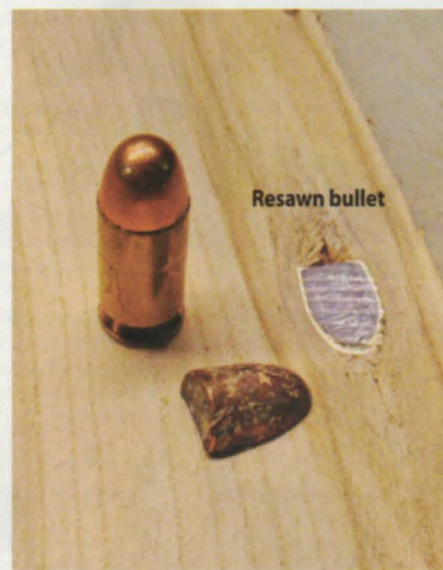

Scanning boards—especially those harvested from "found" wood—with a metal detector will help you avoid surprises such as this bullet, fencing, or nails before they can damage a tool.



INNOVATIVE PRODUCTS SINCE 1989!



SHOP FOX® machines are backed by a 2 Year Warranty!

TRACK SAW

- Motor: 120V, 9A, 1100 watt, 5500 RPM
- Blade diameter: 160mm (6¼")
- Cutting capacity:
 - With track: 1³¹/₃₂" @ 90°, 1⁷/₁₆" @ 45°
 - Without track: 2⁵/₃₂" @ 90°, 1⁵/₈" @ 45°



New

W1832 Track Saw
Track not included

D4362 Guide Rails **D4363** Accessory Pack

14" BANDSAW

- 1 HP, 110V/220V
- Precision ground cast iron table measures 14" x 14" x 1½"
- Blade Size: 93½" (1/8" to 3/4" wide)
- Cutting capacity 13½" (throat)
- Cast iron frame and wheels
- Ball bearing blade guides
- Includes fence and mitre gauge

Feature packed, and an incredible value

W1706 14" Bandsaw



5 HP SPINDLE SHAPER

- Motor: 5 HP, 220V, single-phase, 25A, 3450 RPM
- Precision ground cast iron table measures 35½" x 28" x 2⁵/₁₆"
- Spindle travel: 3¼"
- Spindle sizes: ¾", 1", 1¼"
- Spindle capacity: 4¼", 4⁵/₈", 5¹/₈"

New



W1827 5 HP Spindle Shaper

10" TABLE SAWS with Riving Knife

- 3 HP, 220V, single-phase motor
- Cast iron table size:
 - 27" x 40¼" (W1819) 53⁵/₈" w/extension, (W1820) 74" w/extension)
- Max. rip capacity: (W1819) 29½", (W1820) 50"
- Camlock fence with HDPE face

Free 10" Carbide-Tipped Blade



W1819 10" Table Saw

W1820 10" Table Saw w/ Long Ext. Table

SLIDING TABLE and ROUTER TABLE ATTACHMENTS for W1819 & W1820



SAW NOT INCLUDED

W1821 SLIDING TABLE ATTACHMENT

- Industrial grade anodized aluminum table size: 47" x 9"
- Max. cross cut: 48"

W1822 ROUTER TABLE ATTACHMENT

- Precision-ground cast iron table size: 27" x 20"
- Universal router mount

OSCILLATING BENCHTOP SPINDLE SANDER

- ½ HP, 120V, single-phase, 3.5A
- Table size: 15" L x 11½" W
- 58 Oscillations per minute
- Stroke length: 5/8"
- 2000 RPM (½" spindle)

New



W1831 Oscillating Benchtop Spindle Sander

OUTSTANDING SHOP FOX® DUST COLLECTORS

PORTABLE CYCLONE

New

Only 70½" Tall!

- Motor: 1½ HP, 110V/220V, pre-wired 110V, single-phase
- CFM: 806
- Filter: 2.0 micron, pleated
- 20 gal. steel collection drum with casters
- Inlet: 6" (or 4" x 2" with included Y)
- Maximum static pressure: 10.4"
- Includes remote control

W1823 1½ HP Portable Cyclone Dust Collector



WALL DUST COLLECTOR

SHOP FOX

New

- Motor: 1 HP, 110V/220V, single-phase
- Air suction capacity: 537 CFM
- Bag capacity: 2 cubic feet
- Standard bag filtration: 2.5 micron
- Static pressure: 7.2"

W1826 Wall Dust Collector



3-SPEED HANGING AIR FILTER

SHOP FOX

New

- Motor: ½ HP, 120V, 60Hz, 1A single-phase
- Air flow: 260, 362, and 409 CFM
- Outer filter: 5.0 micron
- Inner filter: 1.0 micron



INCLUDES TIMER AND REMOTE!

W1830 Hanging Air Filter

WOODSTOCK INTERNATIONAL, INC. IS ALSO HOME TO PRO-STICK®, PLANER PAL®, JOINTER PAL®, AND MANY OTHER FINE BRANDS. PLEASE VISIT OUR WEBSITE OR CALL TOLL FREE TO FIND AN AUTHORIZED DEALER NEAR YOU.

SHOPFOX.BIZ

sales@shopfox.biz WHOLESALE ONLY



1-800-840-8420

SHOP FOX® is a registered trademark of Woodstock International, Inc.

Angle finder becomes dead-on height indicator

When setting up my router table for cutting half-lap joints, I figured out a quick and reliable way to adjust router bit height with more accuracy than eyeballing it against a rule.

I needed to raise the router bit $\frac{3}{8}$ " above the table, so I laid a $\frac{3}{8}$ " twist drill bit on the router table and rested a flat piece of scrap atop both bits, as shown. After placing an electronic angle finder on the router table and zeroing the scale, I placed the finder on the scrap and raised the router bit until the angle finder read zero.

—Lester Borja, Lansing, Ill.



Photography by: Lester Borja

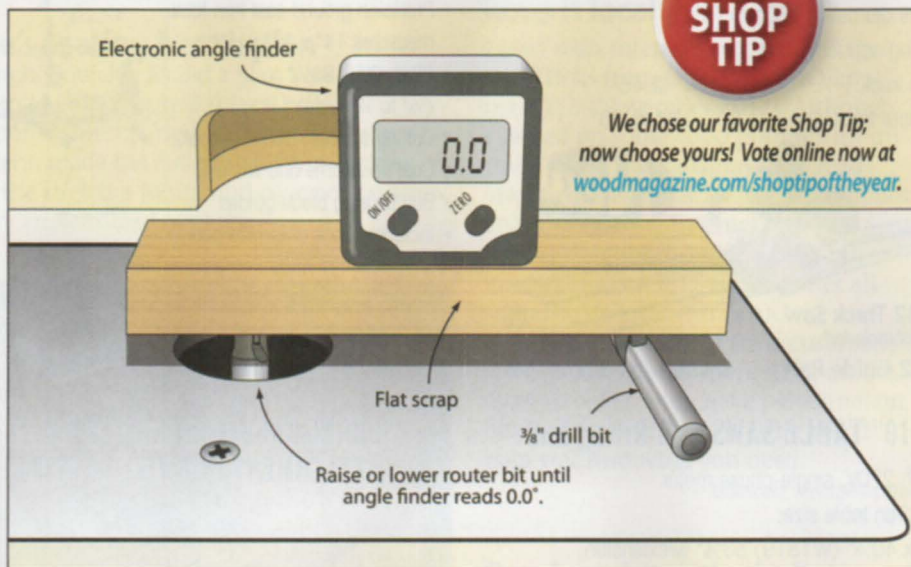

We chose our favorite Shop Tip; now choose yours! Vote online now at woodmagazine.com/shoptipoftheyear.

For sending this issue's Top Shop Tip, Lester receives the Jet 1221VS lathe worth \$800.



HAVE A WOOD-WORTHY TIP?

Tell us how you've solved a workshop stumper. If we print your tip, you'll receive up to \$150. And, if the idea garners Top Shop Tip honors, we'll also reward you with a tool prize from Jet Tools worth at least \$300!

Send your best ideas, along with photos or drawings and contact info, to

shoptips@woodmagazine.com or Shop Tips, WOOD magazine, 1716 Locust St., LS-221, Des Moines, IA 50309-3023.

Because we try to publish original tips, please send yours only to WOOD® magazine. Sorry, submitted materials can't be returned.



DREAM MACHINE GIVEAWAY!



Win woodworking machines worth more than \$5,000 from Jet Tools!

Go online today, and you could be enjoying all of the Jet machines shown at left by the end of this summer! Visit woodmagazine.com/jetdreammachines to sign up. Enter every day, if you like, to increase your chances of winning!

NO PURCHASE NECESSARY TO ENTER OR WIN. Subject to Official Rules at www.woodmagazine.com/jetdreammachines. The Jet Dream Machine Giveaway begins at 12:01 a.m. CT on 01/07/13 and ends at 11:59 p.m. CT on 6/26/13. Open to legal residents of the 50 United States, and the District of Columbia, 21 years or older. Limit one (1) entry per person and per email address per day. Void where prohibited. Sponsor: Meredith Corporation.

EXPERIENCE
REAL
CONTROL



INTRODUCING THE
NEW 1221VS LATHE

60-3600 RPM
VARIABLE SPEED

**FORWARD TO
REVERSE**
SMOOTH TRANSITION

**DIGITAL
READOUT**

**RAPID
BELT CHANGES**



SEE THE VIDEO AT
JETTOOLS.COM/1221VS



STAND BEHIND YOUR WORK™



350+ SERVICE CENTERS NATIONWIDE

INDUSTRY-LEADING WARRANTIES

EXPERT TECHNICAL SERVICE

©2012 Weller Metal Manufacturing Inc. All Rights Reserved.

AWARD-WINNING PERFORMANCE



19-38 Drum Sander



- > INTELISAND™ Technology auto-regulates conveyor, preventing burning or damaging stock
- > Extra wide conveyor to properly support stock over 19" wide
- > Heavy-duty cast iron construction for strength, rigidity and reduced vibration
- > Easiest access to abrasive fasteners of any drum sander on the market

* Shown with optional infeed/outfeed table and supplies

SUPERMAX TOOLS
Makers of Drum, Brush and Wide Belt Sanders

SuperMaxTools.com | 888.454.3401

Shop Tips

Use dowel centers to find centers of dowels

Marking the exact center of a dowel, especially one with a small diameter, can be tricky. To pinpoint dead center each time, try this jig.

First, in a piece of 3/4"-thick stock, use Forstner bits to drill a series of 3/8"-deep holes that match the size of your dowels. Drill a centered 1/4" hole through the dimple made by the Forstner bit's center point.

To use the jig, insert a 1/4" dowel center (no. 42341, \$6.99 for an 8-pack, 800-279-4441, rockler.com) in each hole, point up. Fit the end of a dowel into the appropriate-sized hole and press the dowel into the jig or tap it with a mallet. The resulting dimple clearly marks the dowel's center.

—Len Urban, Rancho Mirage, Calif.

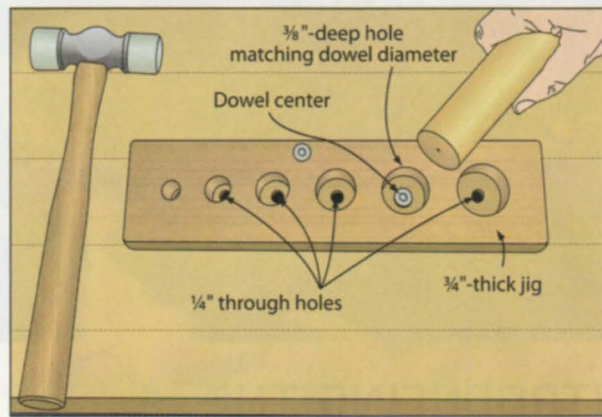

Pop in a liner to eliminate cup cleanup

A high-volume, low-pressure (HVLP) spray unit works great for finishing projects, but it takes just as long to clean up after spraying a small project as it does for big ones. Here's a way to cut down on cleanup time for small jobs, and all you have to do is take a break and grab a soda.

Carefully cut the top off a clean, empty soda can, and drop it into your HVLP sprayer's fluid cup. Fill the can partially with finish. Keep the cup upright while spraying. When done, toss the soda can—no cup to clean up!

—Rud Vrbanic, Indiana, Pa.

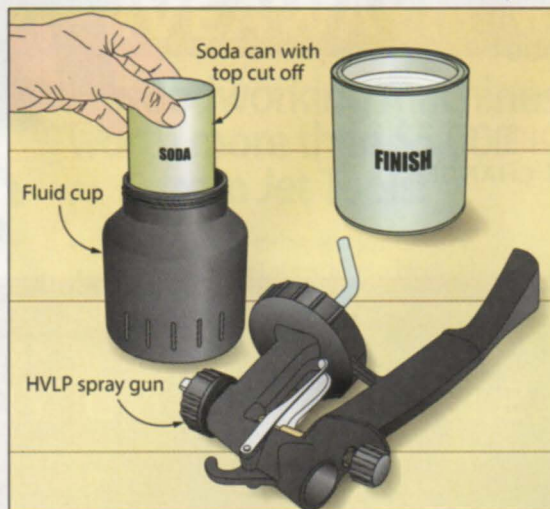

Refinish your future



Let your passion for wood lead you into a new business with a Furniture Medic® franchise.

- Extensive training
- Low initial investment
- Financing available

800-230-2360

furnituremedicfranchise.com

© 2011 Furniture Medic Limited Partnership. All rights reserved.

The world's largest furniture and wood restoration franchise



FURNITURE MEDIC®

Perfect power-strip hanging trick

Lining up protruding screwheads with the keyhole mounting slots on the back of a power strip can be a frustrating trial-and-error process. Here's a foolproof trick that works the first time: Lay a piece of paper over the back of the power strip and, using the side of a pencil lead, make a rubbing of the slots to create a template.

With your pencil, punch a hole through the template where the screws would go. Now tape the template to the mounting location and drive screws through the template holes.

—Serge Duclos, Delson, Que.

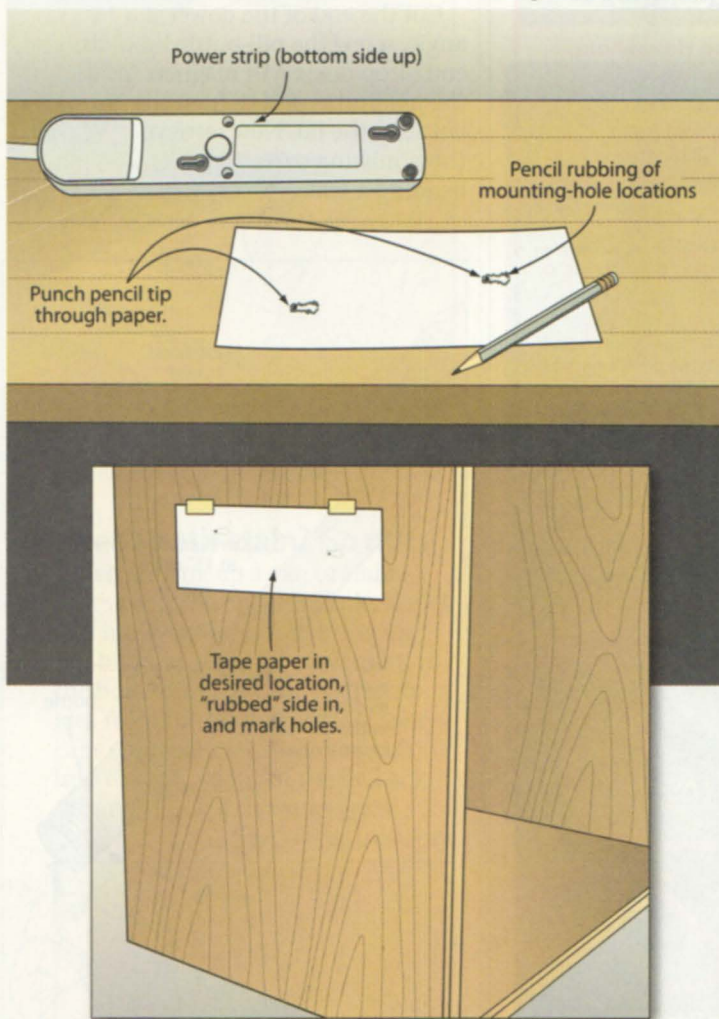

Get a **FREE** Daily Shop Tip
at
woodmagazine.com/tips

Designing and Building High Quality, Made-in- America Dust Collection Systems for 20 years.

Oneida Air V-Systems

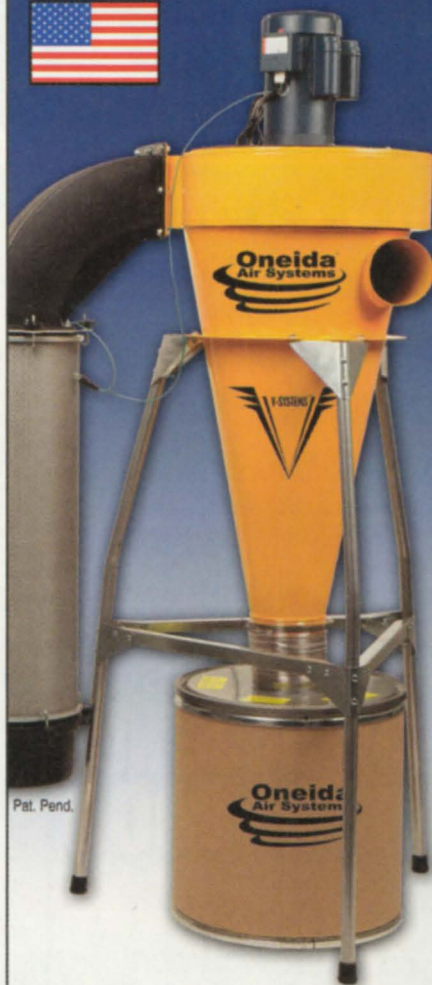

- **GE® HEPA (Certified H-12) Filter Media** for best possible filtration!
See specs on website. Most Systems.
- **High efficiency cyclone** with pat. pend. design - separates 99% of the dust before the filter.
- **Fan / blowers - Premium quality U.S. made industrial motors**, with fan wheels designed for maximum air flow & quiet operation.
- **Built to last a lifetime.**
- **See our complete line of V-Systems at www.oneida-air.com**

Pat. Pend.

Ductwork and Systems

Complete line of 1.5 - 20hp systems and components. Free design consultation.

Free shipping on ductwork orders of \$300+ / 48 states / Some restrictions apply.



Like Dust Collection Systems and Components Since 1993.

Call Today for **FREE** Catalog!
1.800.732.4065
www.oneida-air.com



Dust Collection Since 1993.

NEW!

Burn SAFELY with the STAINLESS STEEL

Portable Burn-Cage™



If you've burned with a steel drum, you know the problems:

- Poor circulation won't allow debris to burn completely.
- Flying embers can ignite surrounding combustibles (like barns and houses).
- Drums are heavy and fill with rain.
- Eventually, the drum will rust.



Old Leaves and Branches
Up in Flames!

Sensitive Financial Documents
Gone Forever!

Burnable Household Waste
Sayonara!

Now Eliminating Your Yard and Household Combustible Waste Couldn't be Easier!

- **Cleaner more efficient fires.** Perforated lid and sidewalls maximize airflow and trap burning embers. High burn temperatures mean thorough incineration with less residue and ash.
- **Lightweight,** portable and folds for easy storage.
- **Peace of Mind.** It's the SAFE way to burn.

77704X © 2013



Order the Burn-Cage™ Today!

TOLL FREE **1-800-657-1008**

www.drpower.com/wood

SPECIAL OFFER

Wood Magazine Readers

SAVE \$70!

Use the phone number or URL at left to save \$70 off list price!

Measure Moisture IN THE WOOD NOT ON THE WOOD



Fast + Accurate!



Deep Readings,
No pins!



Proudly Manufactured & Supported in the USA

Proudly Manufactured & Supported in the USA



800-795-9916

www.wagnermeters.com

Shop Tips

This magnetic grabber is a real pickup artist

It happens to all of us: A small fastener or tool falls off the workbench and rolls to a hard-to-reach spot. Getting down on your hands and knees to recover the lost object gets tiresome. To make the recovery process quick and painless, build this simple magnetic grabber using a hardwood dowel, a pill bottle, and a handful of rare-earth magnets.

Cut the end of the dowel at a 15° angle, screw the pill-bottle lid to its end, drop rare-earth magnets inside the pill bottle, and tighten the bottle to the lid. Now retrieve those missing parts without bending a knee.

—Mark Parenti, Oak Point, Texas

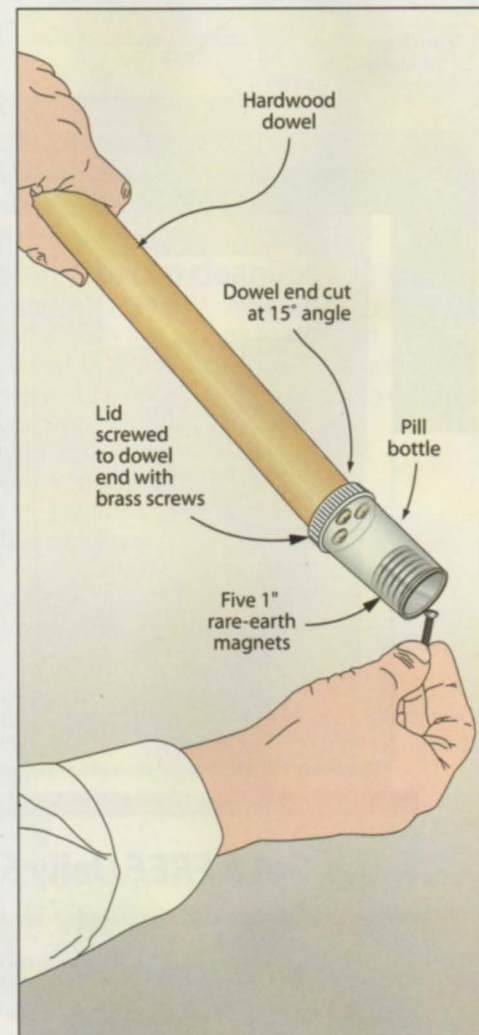

Stair risers make storage wiser

Stumped for space in my basement shop, I literally stumbled upon a solution. My basement stairs don't have risers, so I installed drawers in the open spaces below the treads to add storage space. To save some dough, instead of investing in spendy drawer hardware, I ripped 2x4 stock into narrow strips and mounted them to the inside of the staircase as drawer supports.

—Eric Boland, Batavia, N.Y.

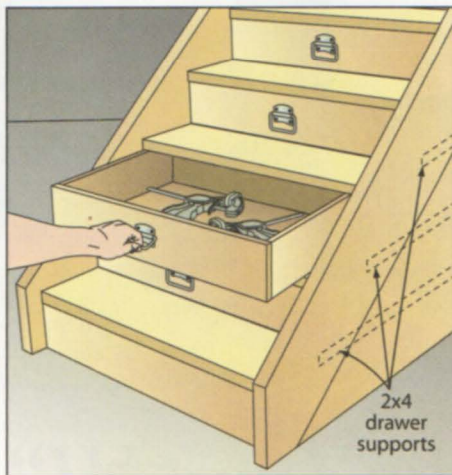

2x4
drawer
supports

Need to stir stain? Go nuts!

When stirring up a can of stain that's been sitting for a while, a stick gets messy and tends to bring up, not break up, chunks of pigment in the bottom of the can. Taking an idea from the book of aerosol spray cans, I tossed a few steel hex nuts into the can, snapped the lid back on, and shook it. It works great!

—John Cusimano, Lansdale, Pa.

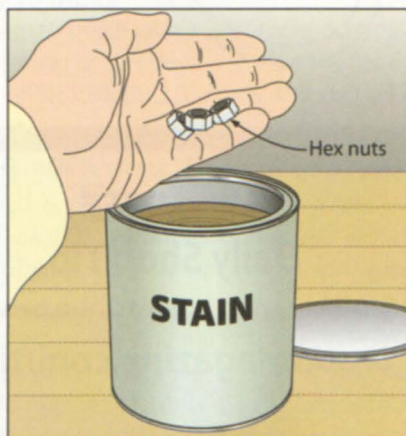

Hex nuts

continued on page 12

Make These High Quality, LED Flashlight Kits And More

BEREA Brand
QUALITY
Writing Pen Kits Comprising
Parts for Making Writing Pens



To Order call **1.877.736.5487** or go to our website www.bereahardwoods.com or email bereahard@aol.com

BereaHardwoods, Co. Inc.
SINCE 1980

18745 Sheldon Rd • Middleburg Hts., OH 44130

ROCKLER
WOODWORKING AND HARDWARE

Create with Confidence™

**FREE
SHIPPING!**

On orders of \$25 or more
Offer expires 5/31/13



Never needs sharpening!

Featuring ergonomic rubber-molded handles, pre-sharpened carbide cutter heads and a stable flattened, stainless steel shank, these tools make turning easier and more rewarding. Just rotate the carbide head when cutter seems dull, and you'll be creating crisp cuts and ribbon-like shavings ... not to mention impressive projects. Mini Carbide Turning Tools – helping you to *Create with Confidence*.

Place your order at **Rockler.com** by entering promotion code 472 at checkout or call **1-800-279-4441**.

Free shipping offer cannot be applied to previous orders or combined with other promotions including Professional Catalog orders. Not valid at Rockler Retail Stores or Independent Resellers. Special shipping charges may still apply for Express, International, Alaska, Hawaii, and heavy/oversize items.



Three Piece Set (45142) \$189.99
Individual tools are sold for \$69.99



For a store near you or free catalog visit **Rockler.com** | **1-877-ROCKLER**

Materials code: 472

Learn new skills from world-class woodworkers.

Weekend With **WOOD**

May 17–19, 2013

Tuition: \$525

Attendance limited to the first 200 registrants!

Learn more and register at woodmagazine.com/weekendwithwood.

Old Masters[®]

Since 1953

EFFORTLESS

Easy-to-use wipe on stains and finishes.



Visit myoldmasters.com for great how-to guides and videos or call us at 800.747.3436 for troubleshooting and project help.

Shop Tips

Welding magnet solves hose-holding problem

To hold a shop-vacuum hose on target on your drill press, simply attach a welding magnet (no. 1939, \$5.99, 800-423-2567, harborfreight.com) to the drill-press column. Then, secure the vac hose to it using a rubber-band retainer like the one shown below.

—Serge Duclos, Delson, Que.

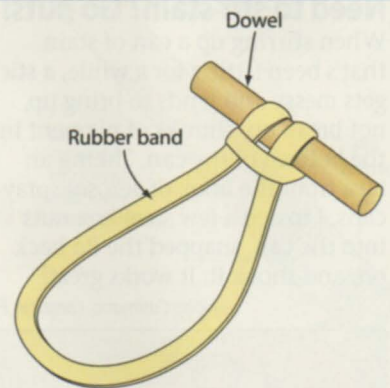
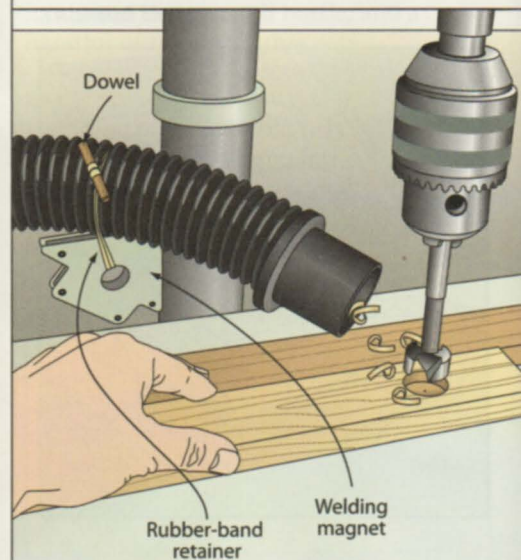

Get a **FREE**
Daily Shop Tip
at

woodmagazine.com/tips

continued on page 14

Penn State Industries

Top Quality, Great Prices and Expert Advice!

1-800-377-7297 • www.pennstateind.com

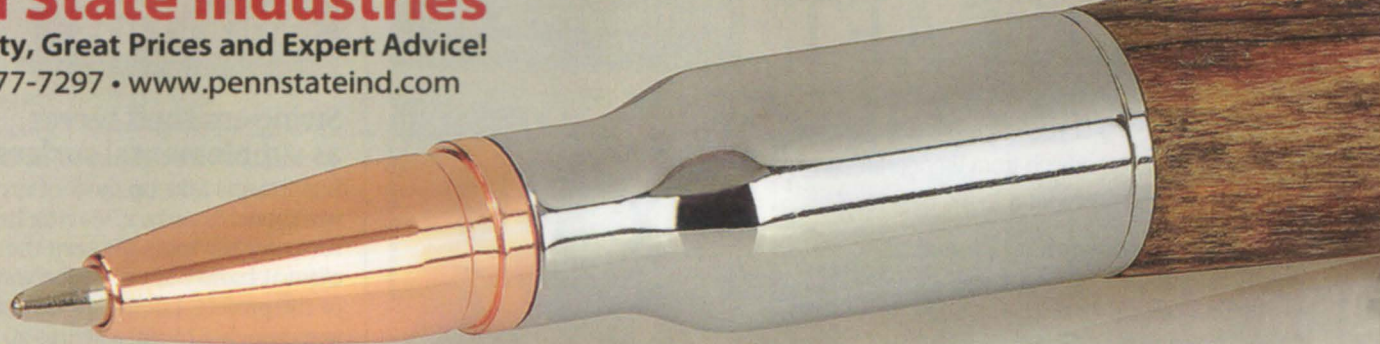

Exclusively at
Penn State Industries.
Patent Pending



Bolt action handle
smoothly advances
and retracts the refill!

“Wow! You Made a Bolt Action Pen?”

Discover the joy of making this completely original and irresistibly fun Bolt Action pen, a gift that will be hard for any hunting or target-shooting enthusiast to put down.

Completely Authentic

Every detail, from the one of a kind bolt-action mechanism to the precision-engineered components, was carefully designed to ensure uniqueness and reliability. The realistic bolt-action handle smoothly advances and retracts to securely lock the refill in place. Includes a bolt-action rifle clip and replica 30 caliber cartridge and rose gold tip for added authenticity.

Easy to Make

So easy to make with a 3/8" tube, no one will believe you made something of this quality in 15 minutes. Requires mandrel, bushings (Item #PKCP3000BU \$5.95) & 3/8" drill bit (Item #PKEXEC-3/8 \$3.95)

Our Customers Love Their Bolt Action Pens!

Rod R. of VA wrote, "This pen kit is Awesome - I LOVE IT!"

Daryell S. of TN wrote, "I am extremely delighted with this pen. The look and feel is remarkable and the craftsmanship is perfect. This already has become my best selling ink pen."

Choose our Original or New Mini Bolt Action Pens!

Our best selling Original Bolt Action Pens are available in four top-quality finishes. Our New Mini Bolt Action pens are available in two finishes, are only 4" long and feature the same authentic styling and use the same accessories as the original.

Easy to start with a FREE DVD! A \$20.95 Value!

Our FREE 45 minute instructional pen making DVD is packed with all of the info you need to start making pens. Order Item #DVD.

Original Bolt Action Pens



Gun Metal shown with refill advanced



24kt Gold shown with refill retracted



Black Enamel & Gun Metal shown with facing clip

	Item #	1-4	5-24	25-49	50+
Chrome	#PKCP8010	\$12.95	\$12.05	\$11.15	\$10.25
Gun Metal	#PKCP8020	\$12.95	\$12.05	\$11.15	\$10.25
24kt Gold	#PKCP8000	\$14.95	\$13.95	\$12.95	\$11.95
Black Enamel	#PKCP8030	\$13.95	\$13.05	\$12.15	\$11.25

3 Bolt Action Pen Kit Starter Pack

You get one pen in Chrome, one in Gun Metal and one in 24kt Gold plus the Bushing Set and 3/8" Drill Bit

#PKCPBAPAK **SAVE \$8 Only \$42.75 SAVE 16%**

Mini Bolt Action Pens **NEW**



Mini in Gun Metal



Mini in 24kt Gold

	Item #	1-4	5-24	25-49	50+
Gun Metal	#PKCP8220	\$10.95	\$9.95	\$9.45	\$8.75
24kt Gold	#PKCP8200	\$12.95	\$11.95	\$11.15	\$10.25

When woodworking is your passion, quality tools, supplies and expert advice from Woodcraft can help take your woodworking to the next level.

Over 20,000 Woodworking Products!

- Hand & Power Tools
- Power Tool Accessories
- Routers & Accessories
- Carving Tools & Chisels
- Workbenches
- Hardwoods & Exotics
- Sanding & Scraping
- Woodburning
- Vises & Clamps
- Files & Rasps
- Project Kits & Supplies
- Clock Supplies
- Planes & Saws
- Woodboring Tools
- Sharpening Supplies
- Finishing Supplies
- Safety Equipment
- Woodturning
- Hardware
- Marking & Measuring
- Cabinetmaking Supplies
- Shop Accessories
- Books & DVDs

Our Exclusive Brands:

Woodcraft offers exclusive products to our customers!

PINNACLE WoodRiver Classic PROJECT PLANS

HIGHPOINT Classic SHOP PLANS WOODCRAFT PLANS.COM

Our Magazine: WOODCRAFT magazine Publishes Six Great Issues A Year!

To Find Your Local Woodcraft Store Or For A Free Catalog, Visit woodcraft.com Or Call 1-800-225-1153.



Shop Tips

Swing-up shelf serves as supplemental surface

Big projects take up most of my workbench's surface, leaving little room for my tools. To keep them close at hand but out of the way of the project, I designed this easy workbench add-on: a swing-up shelf. A 2x4 support arm mounted to the underside of my workbench with a lag screw swings out to prop up the hinged shelf. When no longer needed, I just swing the arm back under the bench and let the shelf swing down, out of the way.

—Gene Dineralter, New London, Conn.

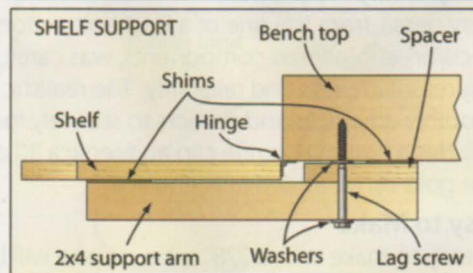
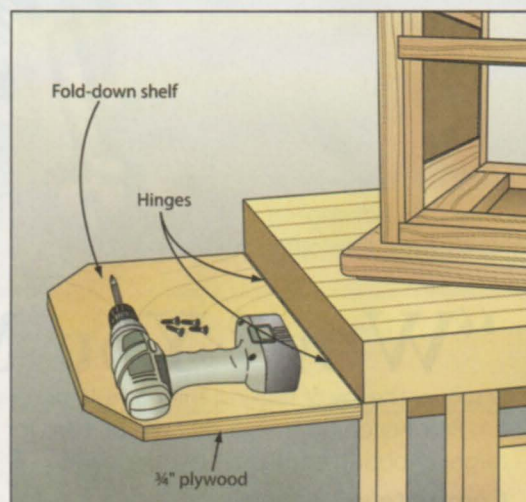

NEW! 25th Anniversary Limited-Edition DR® Field and Brush Mower

Our Lowest Price EVER on a Full-Featured Field and Brush Mower!

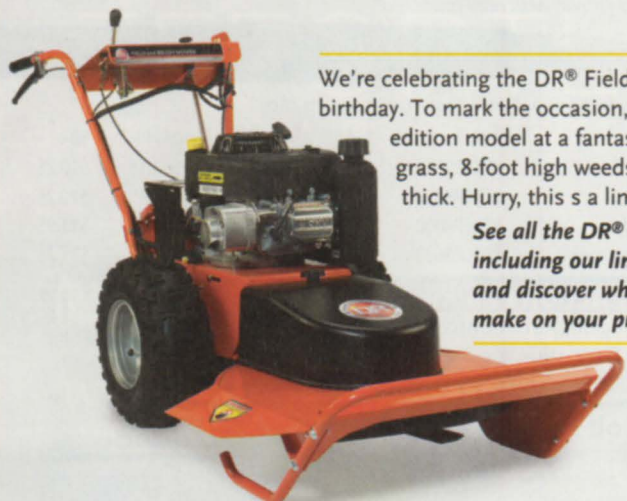

We're celebrating the DR® Field and Brush Mower's 25th birthday. To mark the occasion, we're offering a limited edition model at a fantastic price! Cut 4-foot high grass, 8-foot high weeds, and saplings up to 2" thick. Hurry, this is a limited time offer!

See all the DR® Field and Brush Mowers including our lineup of Tow-Behind models and discover what a difference they can make on your property!



77703X © 2013

Call for a FREE DVD and Catalog!

TOLL FREE 888-213-2037

DRfieldbrush.com



More Terrific Shop Tips



To order call 888-636-4478 or go to

woodmagazine.com/CompleteGuide

Quick-stick clamp pads end dings and dents

F-style clamps prove handy around the shop, but their small metal jaw faces tend to mar wood. For an easy, stick-on solution, I epoxied rare-earth magnets in 2x2" scrapwood pads. No custom fitting necessary; just slap them on the jaw faces and tighten the clamp. 🌲

—Charles Mak, Calgary, Alta.

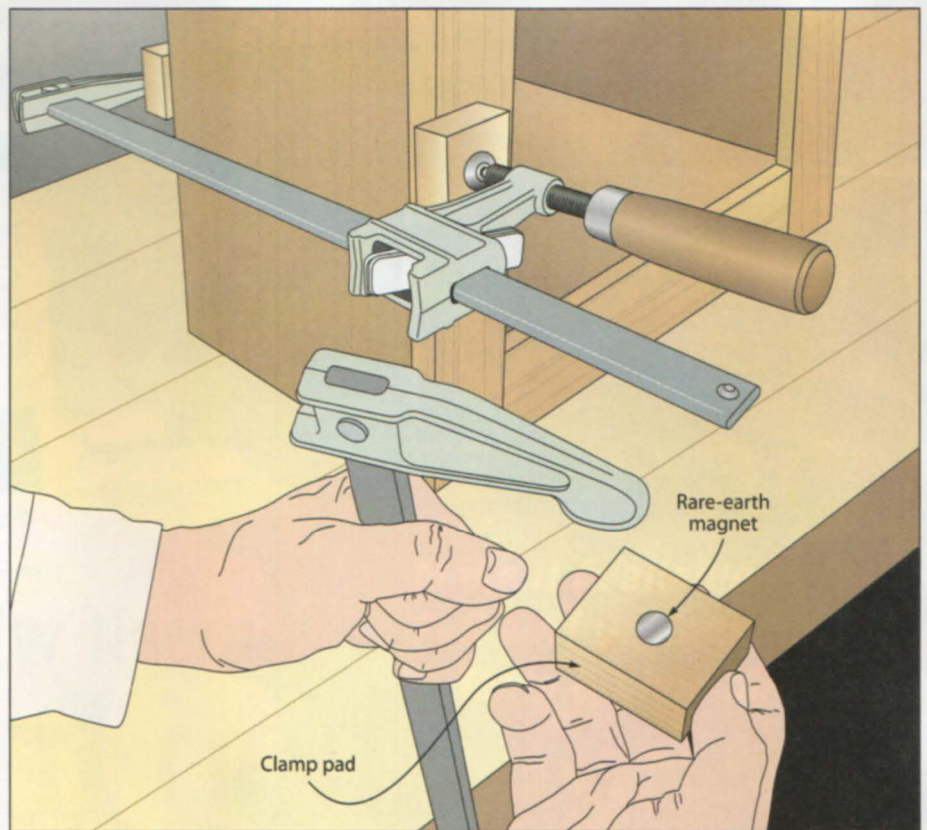

Nanofiber eats the competition's dust!

(FREE with any Tempest Cyclone!)

The best value in dust collection is now the cleanest.

Our Tempest Cyclone Dust Collectors now include Nanofiber filters as a **FREE** upgrade (a \$54 value). Industry leading, Merv 15 rated Nanofiber filters combined with our cyclonic separation process captures 99.98% of wood chips and dust particles to below 1/2 micron. You achieve near surgical quality air and cleaner tools, while practically eliminating dust clean up forever! In addition, Tempest Cyclones never clog, require almost no maintenance and come with a 5 year warranty.

- 2.5 HP - 1450CFM - \$1095
- 3.5 HP - 1700CFM - \$1295
- 5.0 HP - 1800CFM - \$1495
- 2.0 HP - Portable 1025CFM - \$1599

Ask about our solutions for smaller shops starting at only \$295.

SAVE on any system you buy! PSI offers a variety of discounts and offers on dust collectors too numerous to list here. We're your complete resource for everything you need to get the job done right! To get the best deal on the system sized perfectly for your shop and number of tools, **call Bill at (215) 676-7606 x16.**

Penn State Industries
Top Quality, Great Prices and Expert Advice!

1-800-377-7297 • www.pennstateind.com

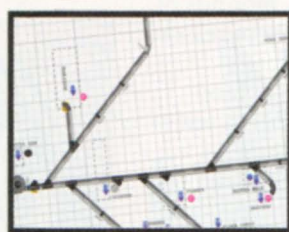

FREE Ductwork Plan
Plus Save \$100 when you purchase any S-series Tempest™ cyclone!
Use Code WOOD23
Call 1-800-377-7297 to redeem
Offer expires 5/1/13 Offer not valid online. Prices subject to change without notice



A Total Loss 6/19/2011



Heavy water damage!



Tornado dropped a tree on my shop...

Protect yourself with a Digital Shop Inventory

Make a photo or video log of your tools for protection in the unlikely event of a natural disaster—such as Hurricanes Sandy or Katrina—fire, or burglary.

If you lost your shop or its contents to a calamity, could you put together a complete list of your tools and supplies from memory after the fact? Having a digital record of your shop's contents makes it easier to work with your insurance company.

Record the details

You probably have a digital camera in your pocket or within arm's reach right now. Virtually every mobile phone shoots digital photos and video of sufficient quality for inventory. (Talk to your cellular provider about adding more storage to your phone, and your options for retrieving and storing those photos or video.) Otherwise, you can find digital cameras that shoot still photos and video for as little as \$50 (plus a \$10–\$15 memory card). And camcorders start at about \$100; You'll also need at least a 16GB memory card, about \$40.

Before you begin taking photos or video, remove dust and wood chips from all tools and worksurfaces to make identification easier. Properly store any potentially hazardous

materials (stain, clear finish, solvents, etc.) in approved fire-resistant metal containers or cabinets.

We talked to several insurance companies, and they agreed you don't need to give them a list of your shop's contents prior to a disaster. But in case they want to see your digital inventory later to sort out a claim, avoid capturing images of potential fire hazards—overloaded electrical outlets, improperly stored finishes, mounds of sawdust—that might give them reason to deny your claim.

Place your portable and benchtop tools on an uncluttered surface, a few at a time. Shoot photos or video of each tool from several angles so they can be identified by brand and tool type, and to provide a gauge of each tool's wear. Then record the identification plate or label on each tool, as shown at right.

Repeat the process for your stationary machines and accessories. Remember to catalog dust-collection equipment, including ductwork and hoses.

Finally, take photos of each workbench, tool stand, organizer, toolbox, and cabinet in your shop, opening any

door, lid, or drawer to shoot the contents inside. If you can't identify each product by its model number, at least be sure to capture the brand name or its well-known color.

If you have receipts for tools, add them to your inventory. If not, don't worry about recording the prices or establishing values. You'll work with your insurance agent to do that, should a need arise.

continued on page 18

IT'S TIME FOR YOUR CLOSE-UP



Zoom in close on each tool's identification label, making sure you can clearly see the model and serial numbers.

Premier

FUSION

HOW CAN THE BEST GENERAL PURPOSE SAW BLADE GET EVEN BETTER?

Make it Available in Thin & Full Kerf Designs for Every Table & Chop Miter Saw!

The Premier Fusion saw blade is the ultimate general purpose saw blade; delivering a glass-smooth, chip-free top and bottom surface while ripping and crosscutting.

This patent-pending blade is the most technologically advanced blade on the market and combines a unique "Fusion" tooth design, exclusive TiCo™ Hi-Density Carbide, superior anti-vibration design and patented Perma-SHIELD® non-stick coating for flawless cutting performance.

Choose from four blades in the full kerf Premier Fusion series – 8", 10", 12" and 14" or try the new thin kerf 10" Premier Fusion for lowered powered saws.



Freud's Fusion Tooth Design vs. Others

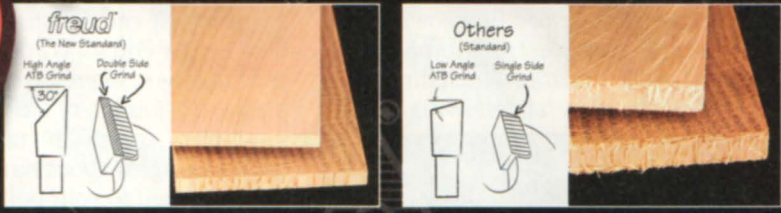

Check out Freud's Facebook page and download our FREE monthly woodworking plan!

 www.facebook.com/Freudtools

www.freudtools.com

1-800-472-7307

freud®



Now store your list safely

Once you've imaged all your tools, you need to preserve those recordings in a couple of safe places. You don't want to lose your only record in the same disaster that destroys your shop!

Transfer your photos or videos onto a recordable DVD or CD, flash drive, SD card, or portable hard drive, like those shown at *right*. Make a couple of copies; store one in a fire safe in your home and the other off-site: a safe-deposit box or a fire safe in a friend's house in another town. For good measure, create a spreadsheet or slide show of your tools' photos and information, and send it to yourself via Web-based email so you can retrieve it from any computer later.



Update your inventory every 2 to 3 years, storing it on newer media. Don't let your tool inventory or storage media become obsolete.



Prepare now: Don't put it off until after disaster strikes

For expert advice on this topic, we talked with woodworker Tom Iovino (*below*), who works as a disaster preparedness and response director in central Florida. In his 14 years in this role, Tom has helped homeowners and renters recover from tornadoes, fires, and hurricanes—including time in New York last fall following Sandy's



devastation. Tom gives the following insights into better preparing your home and shop for a potential disaster:

- ▶ A typical homeowner's insurance policy will cover most hobbyist tools against theft and disasters. But if you own higher-end tools and machines (a cabinet saw, big resaw bandsaw, 15" planer, 12" jointer, or Lie-Nielsen hand-plane collection), talk to your insurance agent about purchasing a rider attached to your policy to cover these higher-priced tools.
- ▶ You'll also need special coverage for antique, handmade, or one-of-a-kind tools that hold greater value than more common versions. Get a written appraisal to substantiate that value.
- ▶ Find out if your insurance policy provides replacement coverage, which would pay to buy the same or comparable tools at today's prices. Many

policies pay only depreciated values, which could leave you short in replacing your tools.

- ▶ Renters: Check with your insurance agent to make sure your contents policy covers shop tools and materials. Most do, but find out.
- ▶ Homeowners and renters insurance policies do not cover flooding (including storm surge), although they cover all other natural disasters, unless declared in the policy. All flood insurance comes separately through government programs; talk to your insurance agent if you need that coverage. For more information, go to floodsmart.org.
- ▶ The Insurance Information Institute (iii.org) offers a variety of reference materials to help you prepare for disasters as well as recover from one afterward. 🌱

Nourish and Protect Wood with Odie's Line of Products

All Odie's products are proprietary blends of oils and waxes, born out of inspiration, hard work and a driving need to solve problems specific to the woodworker. They are the culmination of 30+ years of research, development and field testing in the most extreme environments which have produced products that outperform and have better coverage than similar products – plus all Odie's products are nontoxic, food-safe and made in the USA.

Odie's Oil Clear	Odie's Oxi Oil
157861 2 oz.	157862 2 oz.
856038 9 oz.	157863 9 oz.

Odie's Wood Butter	Odie's Wax
157865 9 oz.	157864 9 oz.

Odie's Solvent
157866 qt.



For A Free Catalog Or To Find Your Local Woodcraft Store, Visit woodcraft.com Or Call 800-225-1153.
For Information On Woodcraft Retail Franchise Opportunities, Visit woodcraftfranchise.com

Great Ideas For Your Shop



Pipe-clamp Support U-blocks

Controlling pipe clamps is easy with a little help from your workbench's dog holes.

Forget about frustrating panel glue-ups where your clamps scoot around or tip. If your workbench has two parallel rows of dog holes in its top, you can easily hold pipe clamps in place with these doglike U-blocks.

Because they raise the clamp's bar and jaws completely off the benchtop, you'll encounter less resistance when making adjustments. Consider making multiple pairs for those especially large panel glue-ups.

To make a matching pair, first cut a 1½"-thick piece of scrap to 3×3¾". Then, drill the centered dowel holes on opposite edges [Drawing 1]. Drill either a ¾" or 1" hole (based on the diameter of your pipes) through the center of the block's face.

Rip the block in half. Round over the edges of each block with a ⅛" round-over bit in your router table; then glue in 2½"-long dowels sized to fit the dog holes in your benchtop [Drawing 2].

Project design: Rod Cox, St. Paul, Iowa

1 CUTTING/DRILLING DIAGRAM

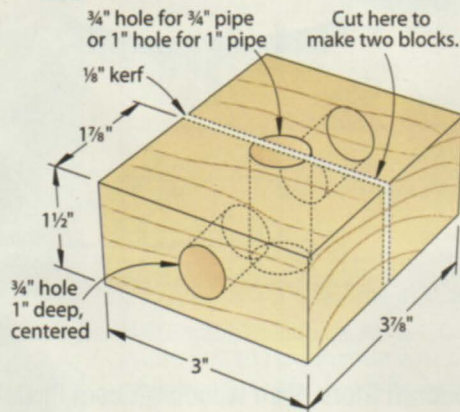

2 U-BLOCK ASSEMBLY

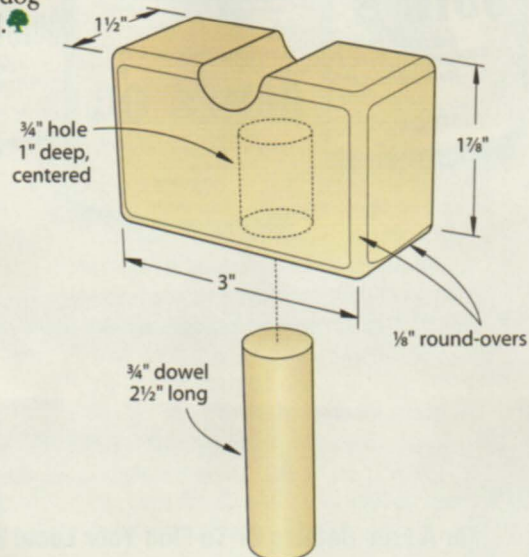



✓Yes



✓Yes



✓Yes



✓Yes

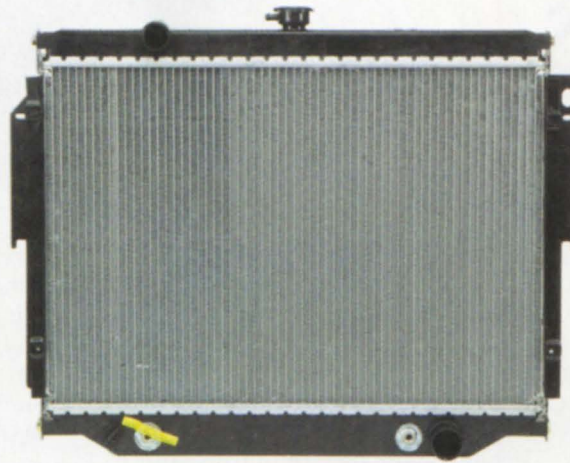

✓Yes



xNo

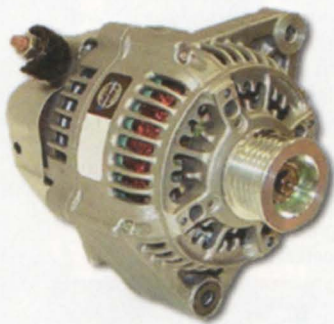

✓Yes



✓Yes



✓Yes

✓ Reliably Low Prices
✓ Easy To Use Website
✓ Huge Selection
✓ Fast Shipping



ALL THE PARTS YOUR CAR WILL EVER NEED

GO TO WWW.ROCKAUTO.COM ROCKAUTO, LLC (EST. 1999)

Before making sawdust, saw some logs

The straight poop on how a newborn helped *The Wood Whisperer* improve his shop safety practices

I thought I knew what it meant to be tired. In college, I would routinely pull off espresso-fueled, all-night study sessions only to find I could barely keep my eyes open while taking the test. But it wasn't until 12 years later that I'd discover the true meaning of real fatigue.

I was right in the middle of building my split-top Roubo workbench and I had a deadline to meet when my son, Mateo, was born prematurely. For the first four months of his life, his excessive digestive discomfort brought both my wife and me a brand of fatigue that can only come from having a crying baby scream in your face all night, every night, for days on end.

During that four-month period, I injured myself more times than I had previously in my entire career. We're not talking about hospital visits—just small cuts and scrapes from hand tools

and a few close calls with power tools. But, honestly, I'm just thankful I made it out alive! Being physically and mentally worn down is a dangerous mix in the woodshop.

The problem with fatigue is that it's like being mildly intoxicated. It affects your coordination. It impairs your judgment. You become complacent and lazy. You let your fingers get closer to cutting edges. You don't take the time to set up safety devices. You might even find yourself uttering the phrase, "It's just one cut!" You could be the most safety-conscious woodworker on the planet, but all of your safety training goes out the window if you compromise your ability to make good decisions.

Those continuous—and painful—warnings forced me to institute a mental double-check at the door of the shop, pausing to honestly answer the question, "Do I have any business

working with tools right now?" Sometimes the answer is no, and I just don't allow myself to go into the shop. Instead, I stay in the office editing video, designing my next creation, or simply reading the latest copy of *WOOD* magazine. Like my good buddy Ice Cube says, "Check yo'self before you wreck yo'self!" 🌱

Woodworker's Safety Week May 6–10

Marc Spagnuolo started Woodworker's Safety Week as a yearly reminder to woodworkers to double-check their workshop safety practices. "Many hazardous occupations have required safety training," Marc says. "But because woodworking is a hobby, many of us learn about safety the hard way."

Each first week of May, woodworking blogs and podcasts around the globe turn their attention to safe workshop practices to remind fellow woodworkers to put safety first.

Find out more about Safety Week at thewoodwhisperer.com.



Woodworker's Safety Week is a good time to double-check the contents of your first-aid kit. A ready-made kit, such as this one from zeemedical.com, should be restocked when components are used up or expire.



With fingers far too close to the blade, alarm bells should be sounding in this woodworker's head. Fatigue can cause lapses in judgment that suppress those warnings.



Marc Spagnuolo gave up a glamorous career in the biotech industry to make sawdust. Through his website (thewoodwhisperer.com) and his guild videos (thewoodwhispererguild.com), he's become a one-man online powerhouse of woodworking information.

CREATE YOUR OWN MASTERPIECE

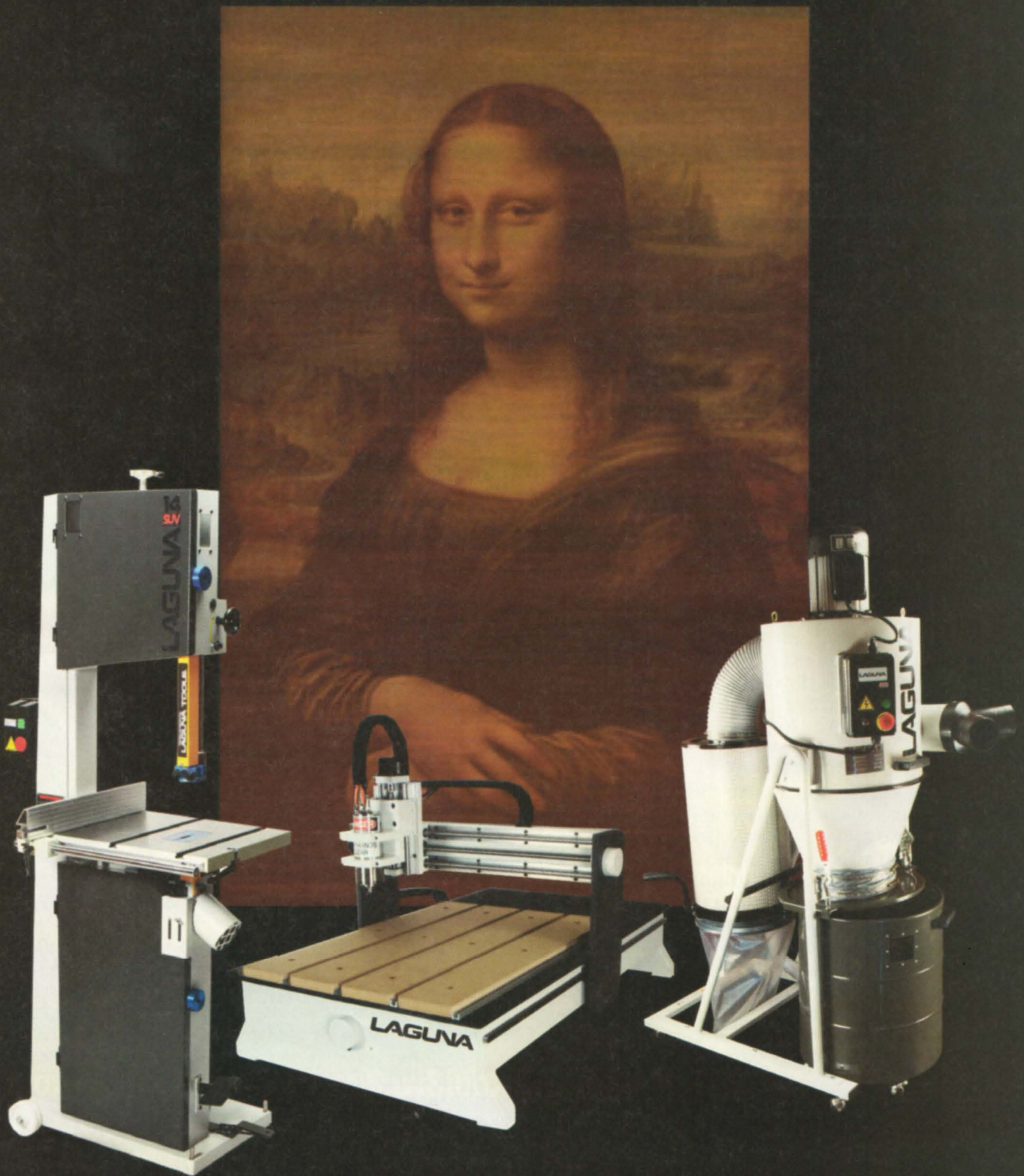

FOR MORE INFORMATION CALL US AT 800.234.1976

LAGUNA
LAGUNATOOLS.COM



Hat and Coat Rack



BASIC-BUILT™

GREAT PROJECTS MADE SIMPLE.

TOOLS NEEDED



Dimensions: 26 3/4" L x 8" H x 10 3/4" D

From the time you leave the lumberyard 'til the last coat of finish dries, this project won't take more than a weekend to complete. Make it hold as many hats and coats as you please by simply adding more slats and spacers and lengthening the back and tubing.

How to get the hang of it

1 Prepare nine 3/4x2x26" blanks. (We chose oak.) From each blank, crosscut two 10"-long slats (A) [Photo A]. From the cutoffs, crosscut two 2"-long spacers (B). [See the **Shop Tip**, right.]

2 Set two slats (A) aside to use on the ends of the rack. Lay out and drill a 3/4" hole through a third slat [Drawing]. Stack this slat on top of four other slats with their ends and edges flush. Drill through three slats, stopping just as the drill bit contacts the bottom slat [Photo B]. Place the bottom slat on top of a stack of four new slats and repeat this process until you have drilled through all but the two end slats set aside earlier. Sand the slats and spacers (B) to 220 grit.

3 Retrieve the two end slats (A). Clamp each one to a drilled slat and press a 3/4" spade bit through the drilled slats to mark the center of the hole. Set the drilled slats aside and using a 3/4" spade bit with a short centerpoint, drill a 3/8"-deep hole centered on these marks [Drawing].

4 Glue two spacers to one slat that has a through hole—this will be the "starter slat" [Photo C, Drawing]. Then glue one spacer (B) to each of the remaining slats (A) with a through hole.

SHOP TIP

Crosscut small parts safely

When cutting short pieces such as the spacers (B), maintain a good grip on the stock while keeping your hands in safe positions by holding the part with the eraser end of a pencil. During the cut, press the blank back toward the miter-gauge extension and the stopblock.

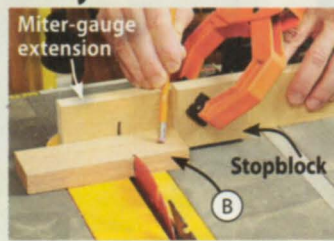

5 Cut the back (C) to size [Drawing] and sand it to 220 grit, easing the sharp edges.

6 Cut a 24" length of 1/2" electrical metallic tubing (EMT). Begin assembling the coat rack by sliding the starter slat (A/B) onto the EMT. Apply glue to the face of one of the starter slat's spacers. Slide a slat/spacer assembly onto the EMT and clamp it to the starter slat. Place the back (C) on your bench and use it to help align the back ends of the slats [Photo D]. Add and clamp spacer/slat assemblies until all but the end slats (A) have been glued together. Glue the end slats to each end of the assembly, trapping the EMT.

Quick Tip! Either place a piece of waxed paper under the assembly while the glue dries or remove it from the bench to prevent squeeze-out from gluing the rack to the bench.

YOU'VE GOT UNTIL APRIL 30th WHICH FREE UPGRADE WILL YOU CHOOSE?

\$199.00 USD
Value

FREE Overarm Dust Collection

Option 1.



FREE Mobile Base

Option 2.

\$199.00 USD
Value

Now is the time to buy a SawStop. Do it today.

Buy a 3.0HP or 1.75HP Professional Cabinet Saw between March 1 and April 30, 2013, and we'll offer you the upgrade option of your choice (Integrated Mobile Base or Overarm Dust Collection*) – FREE! While supplies last. See website for details.

*Overarm Dust Collection requires a DC Blade Guard, which is included with the 3.0HP Professional Cabinet Saw but must be purchased for the 1.75HP model.



sawstop.com/upgrade

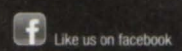

A STOPBLOCK: THE GREAT EQUALIZER

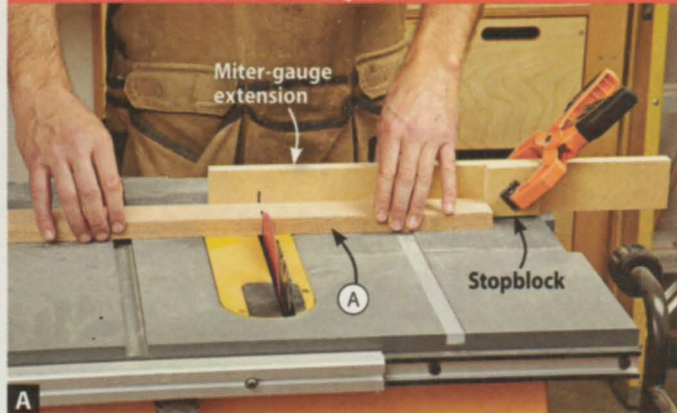

A To cut the slats (A) and spacers (B) to identical lengths, clamp a stopblock to a miter-gauge extension. Leave a gap below it for sawdust relief.

DRILLING A STACK ENSURES ALIGNMENT

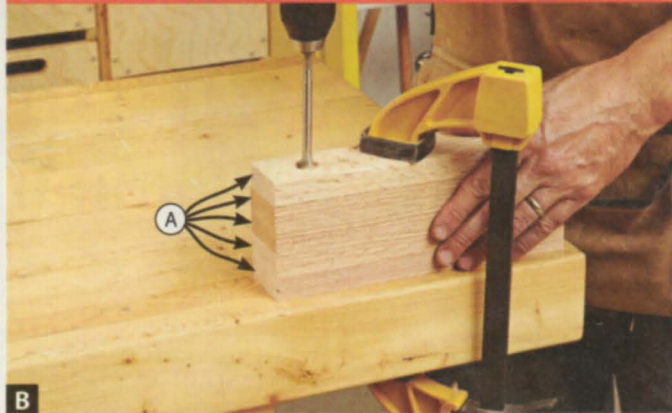

B Keep the bit perpendicular as you drill through the slats (A). Check your progress as you work to prevent drilling through the bottom slat.

MAKE A SERIES OF SUBASSEMBLIES

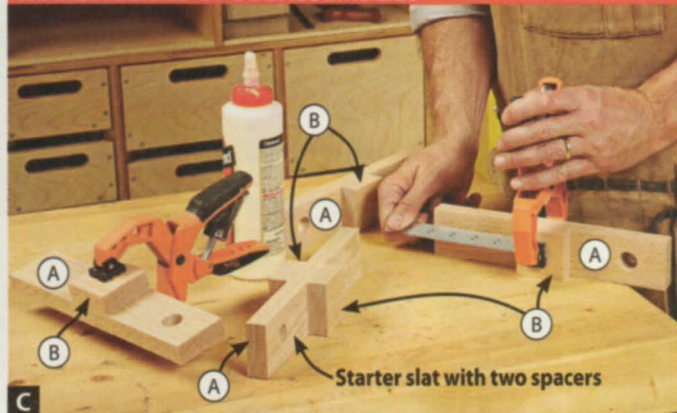

C Clamp a spacer (B) 4" from either end of each slat (A). Make sure the grain runs the same direction on both pieces, and keep the edges flush.

KEEP THE SLATS IN LINE

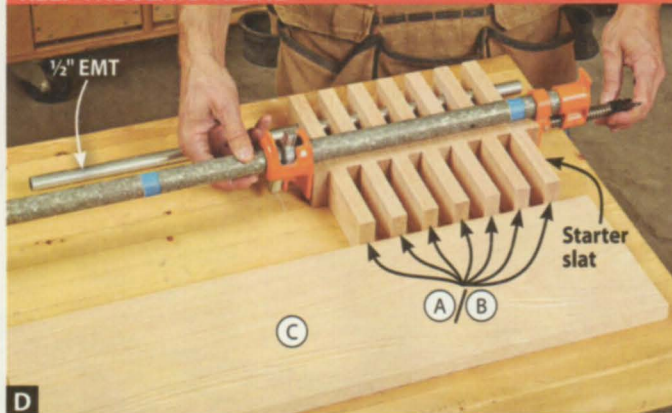

D The EMT, back (C), and a flat bench keep the ends and edges of the slat/spacer (A/B) assemblies flush during glue-up.

7 Sand the top and bottom edges of the slats and spacers to 220 grit to create a smooth, flat surface. Sand only the front ends of the slats to 320 grit.

8 Determine where your coat rack will hang. Mark screw holes on the back (C) that align with wall studs and drill $\frac{5}{32}$ " shank holes on these marks [Drawing]. **Note:** To support a fully loaded coat rack, secure the rack only to wall studs; do not use hollow-wall hangers. Clamp the slat/spacer (A/B) assembly to the back, 1½" from the top edge [Drawing]. Drill $\frac{3}{32}$ " countersunk pilot holes through the back and into each end slat (A) and the sixth slat from each end. Screw the slat/spacer assembly to the back.

9 Apply a finish. To reach into the spaces between the slats (A) and to prevent drips, we sprayed on three coats of a water-based polyurethane. After the finish dries, lay out the positions of the coat hooks [Drawing] and screw them in place. Then, screw the rack to the wall, using #8 finish washers under the screwheads. 🌲

Materials List

Part	FINISHED SIZE			Matl.	Qty.
	T	W	L		
A slats	$\frac{3}{4}$ "	2"	10"	O	17
B spacers	$\frac{3}{4}$ "	2"	2"	O	16
C back	$\frac{3}{4}$ "	8"	26 $\frac{3}{4}$ "	O	1

Materials key: O—oak.

Supplies: #8x2" flathead screws (8), #8x3" flathead screws (4), #8 nickel-finish washers (4), ½x24" electrical metallic tubing.

Bits: $\frac{3}{32}$ ", $\frac{5}{32}$ " drill bits, $\frac{3}{4}$ " spade drill bit.

Source

Brushed-nickel coat hooks: National Hardware no. N325-506 [pack of 2], available at hardware stores and home centers.

Produced by **Craig Rueggegger** with **Kevin Boyle**
Project design: **Kevin Boyle**
Illustration: **Lorna Johnson**

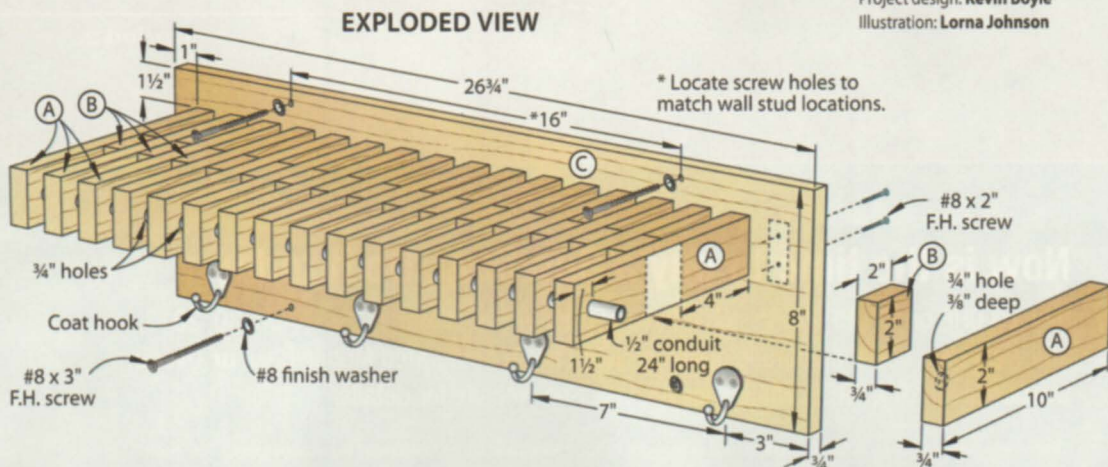

How to Outsmart a Millionaire

Only the "Robin Hood of Watchmakers" can steal the spotlight from a luxury legend for under \$200!

I wasn't looking for trouble. I sat in a café, sipping my espresso and enjoying the quiet. Then it got noisy. Mr. Bigshot rolled up in a roaring high-performance Italian sports car, dropping attitude like his \$14,000 watch made it okay for him to be rude. That's when I decided to roll up my sleeves and teach him a lesson.

"Nice watch," I said, pointing to his and holding up mine. He nodded like we belonged to the same club. We did, but he literally paid 100 times more for his membership. Bigshot bragged about his five-figure purchase, a luxury heavyweight from the titan of high-priced timepieces. I told him that mine was the *Stauer Corso*, a 27-jewel automatic classic now available for only \$179. And just like that, the man was at a loss for words.

Think of Stauer as the "Robin Hood of Watchmakers." We believe everyone deserves a watch of uncompromising precision, impressive performance and the most elegant styling. You deserve a watch that can hold its own against the luxury classics for a fraction of the price. You'll feel the quality as soon as you put it on your wrist. This is an expertly-crafted time machine... not a cry for attention.

Wear a mechanical masterpiece for only \$179! We surveyed our customers. As intelligent, high net worth individuals, they have outgrown the need to show off. They have nothing to prove; they already proved it. They want superb quality and astonishing value. And that's exactly what we deliver.

The *Stauer Corso* is proof that the worth of a watch doesn't depend on the size of its price tag. Our factory spent over \$40 million on Swiss-made machinery to insure the highest quality parts. Each timepiece takes six months and over 200 individual precision parts to create the complex assembly. Peer through the exhibition back to see the 27-jeweled automatic movement in action and you'll understand why we can only offer the *Corso* in a limited edition of 14,999.

Our specialty is vintage automatic movements. The *Corso* is driven by a self-winding design, inspired by a 1923 patent. Your watch will never need batteries. Every second of power is generated by the movement of your body. The black dial features a trio of date complications including a graphic day/night display. The *Corso* secures with a two-toned stainless steel bracelet and is water-resistant to 3 ATM.

Your satisfaction is 100% guaranteed. Test drive the *Stauer Corso*. If you don't love it, send it back within 30 days and we'll refund every dollar of your purchase price. Spending more doesn't make you smarter. But saving thousands on a watch this stunning will leave you feeling (and looking) like a genius!

A Stauer Exclusive Not Sold in Stores

Ostentatious Overpriced Competitors Price ~~\$14,575.00~~
Stauer's Corso Timepiece..... only \$179 +S&P

PLUS receive our Stauer Flyboy Optics™ Sunglasses FREE— a \$99 value!

Call now to take advantage of this fantastic offer with our 30-day money back guarantee.

1-800-859-1626

Promotional Code CSW318-03
 Please mention this code when you call.



Exclusive OFFER!

Order the *Stauer Corso* and these *Stauer Flyboy Optics™* Sunglasses (a \$99 value) are yours **FREE!**



Limited Edition... Order Today!

Scan for additional information on the *Corso* Watch



Stauer®

14101 Southcross Drive W.,
 Dept. CSW318-03
 Burnsville, Minnesota 55337
www.stauer.com



Dimensions: 49½"W × 31½"D × 39½"H
 Approximate lumber cost: \$340;
 Dust collector and related items: \$245

Dust-collecting Tool Stand

A debris separator, effective air filter,
 and mobile worksurface all rolled into one



Invest a weekend in building this simple glued-and-screwed plywood cabinet outfitted with a low-dough dust-collection blower and you're ready to stop sawdust—from big chips to microscopic airborne particles—in its tracks. You need only run a flex hose from its 4" side port to any dust-spewing

machine, be it nearby or sitting on its sturdy worksurface. As shown in the **Separator Airflow Drawing** on the *next page*, nearly all of the debris settles in the cart's large drawer for convenient disposal; the airborne stuff settles in its small drawer after passing through the blower or gets trapped in the filters.

BIG HOLES START WITH LITTLE HOLES



A Mark the 4" hole in the baffle (C) with a compass, bore a $\frac{3}{4}$ " blade start hole near its inside edge, and cut along the marked line with a jigsaw.

GLUE AND SCREWS GET 'ER DONE

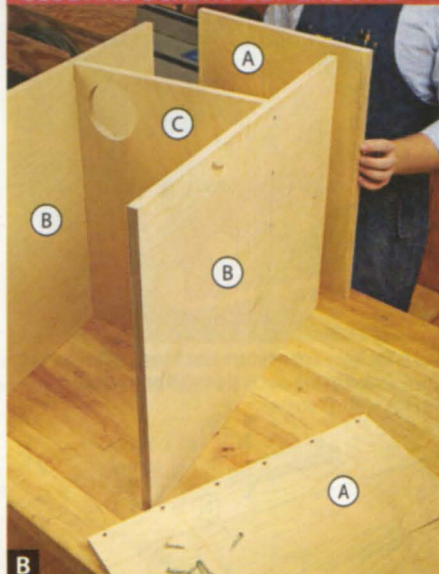

B After drilling countersunk pilot holes, apply a bead of glue and screw together the separator box ends (A), inner sides (B), and baffle (C).

ATTACH THE OUTER SIDE



C Apply glue to the outer faces of the inner sides (B). Position the outer sides (D) and clamp or weight the pieces until the glue has dried.

SEPARATOR AIRFLOW

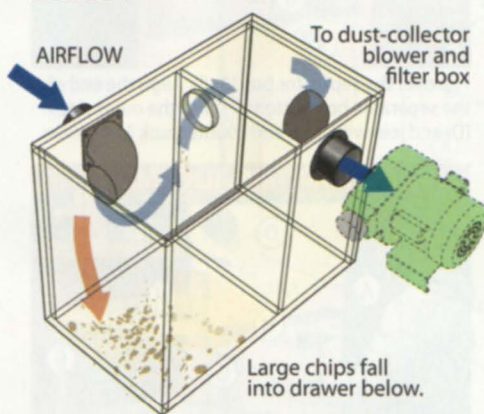

First, build the separator box

1 From $\frac{3}{4}$ " plywood (we used Baltic birch but any good-quality plywood will do), cut to size the separator-box ends (A), inner sides (B), baffle (C), and outer sides (D) [Materials List, page 33; Drawing 1]. For efficient cutting from 4x8' sheets refer to the **Cutting Diagram** on page 33. Cut the 4" hole in the baffle [Photo A]. You will cut the other holes later.

2 Dry-clamp parts A-C, ensuring they are square with each other [Drawing 1]. Drill countersunk pilot holes every 4" along the butted joints. Unclamp and assemble with glue and $\frac{1}{2}$ " screws [Photo B].

3 Glue the outer sides (D) to the inner sides (B) [Photo C]. Align the long edges

1 SEPARATOR BOX

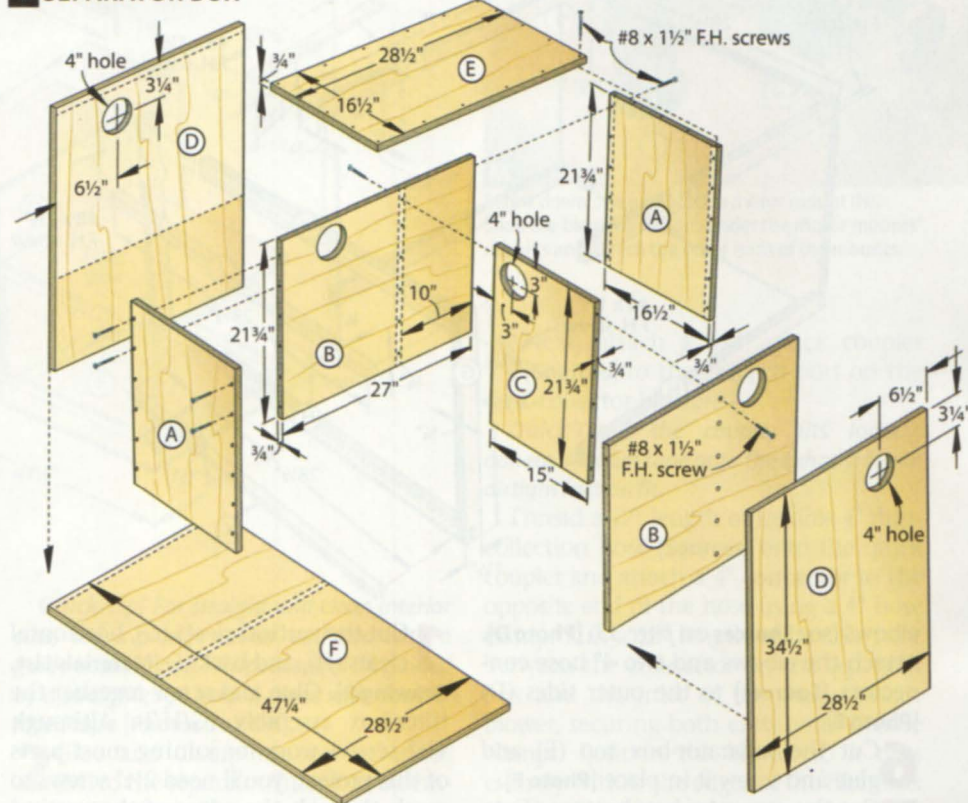

of the ends (A) and the outer sides (D) flush, with the top edges of the outer sides higher than the tops of the inner sides (B) by the thickness of your plywood.

Note: The dimensions in this project assume your plywood is exactly $\frac{3}{4}$ " thick. But plywood thicknesses vary and your stock will most likely measure a bit under $\frac{3}{4}$ " (our Baltic birch ply measured $\frac{11}{16}$ " thick). Keep that in mind

as you cut your parts; measure for pieces that fit onto or into existing assemblies, and adjust dimensions accordingly.

4 Mark 4" holes on both outer sides (D) [Drawing 1]. Cut the holes as you did earlier through both the outer sides and inner sides (B).

5 Cut the straight ends off two $\frac{4}{8}$ "-flange plastic dust-collection

A LITTLE OFF THE ELBOW, PLEASE



D Clamp the flange of the elbow to your workbench to steady it. Then hacksaw off the straight portion of the unflanged end.

ATTACH THE DUST FITTINGS

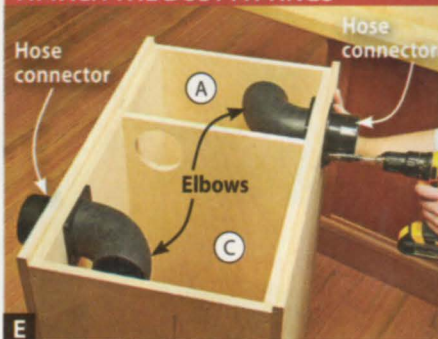

E Align the hose connectors and flange elbows over the 4" holes in the outer sides (D) and attach the fittings with 1" screws.

TOP OFF THE SEPARATOR BOX



F Apply a bead of glue to mating surfaces, align the separator-box top (E), and attach with countersunk 1½" screws.

2 FILTER BOX

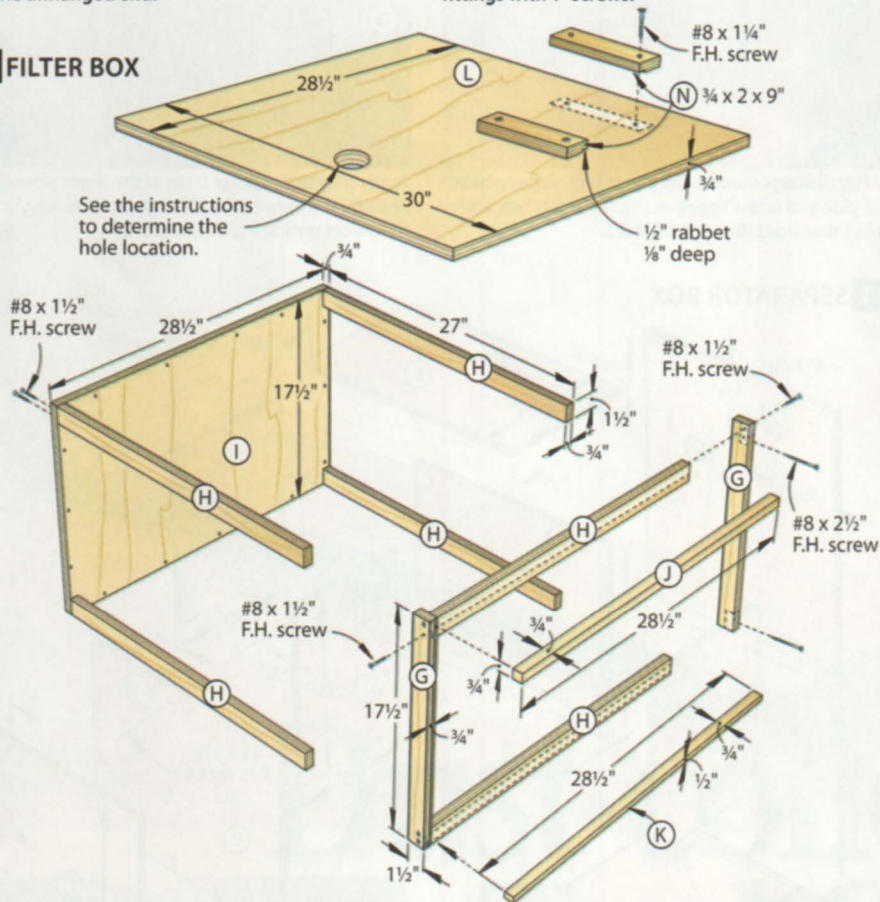

elbows (see **Sources** on page 33) [Photo D]. Attach the elbows and two 4" hose connectors [Sources] to the outer sides (D) [Photo E].

6 Cut the separator-box top (E) and glue and screw it in place [Photo F].

7 Cut the separator-box bottom (F) to size [Drawing 1] and attach it to the separator-box assembly (A–E) [Photo G].

Next, construct the filter box

Note: We sized this project to work with a Grizzly 1-hp, model G0710 dust collector [Sources] that stands about 13¾ tall. You may have to alter the height of the filter box to accommodate a different dust collector.

1 Cut the vertical cleats (G), horizontal cleats (H), and back (I) [Materials List, Drawing 2]. Glue and screw together the filter-box assembly (G/H/I). Although 1½" screws work for joining most parts of this project, you'll need 2½" screws to reach through the edges of the vertical cleats and into the horizontal cleats.

2 Attach the filter-box assembly (G/H/I) to the separator box (A–F) [Photo H].

3 Cut the top spacer (J) and bottom spacer (K) to size from ¾"-thick maple, and the filter-box top (L) to size from ¾" plywood [Drawing 2]. Glue and clamp these pieces to the filter box

BOTTOM UP FOR ASSEMBLY



G Flip over the separator box (A–E). Align the end of the separator-box bottom (F) with the outer sides (D) and join with glue and countersunk 1½" screws.

SPACERS MAINTAIN ALIGNMENT

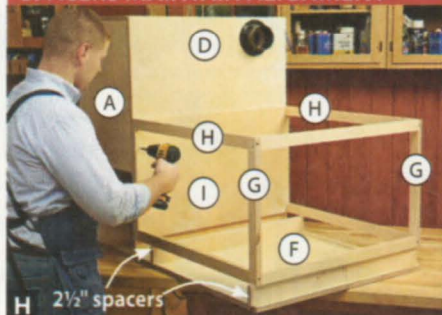

H 2½" spacers
To create space for the drawer, place two 2½"-tall scrapwood spacers beneath the filter box (G/H/I) to hold it in position as you attach it with 1½" screws.

COMPLETE THE FILTER BOX

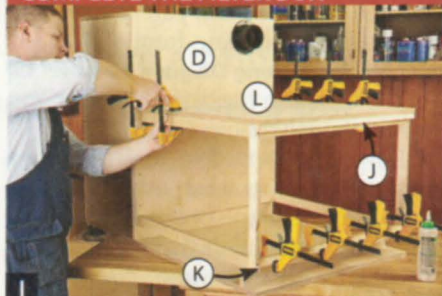

I Attach the top and bottom spacers (J, K) with glue and clamps. Do the same with the filter-box top (L), clamping it on three sides.

YOUR ROUTER TO THE RESCUE ON STRAIGHT CUTS IN SHEET GOODS

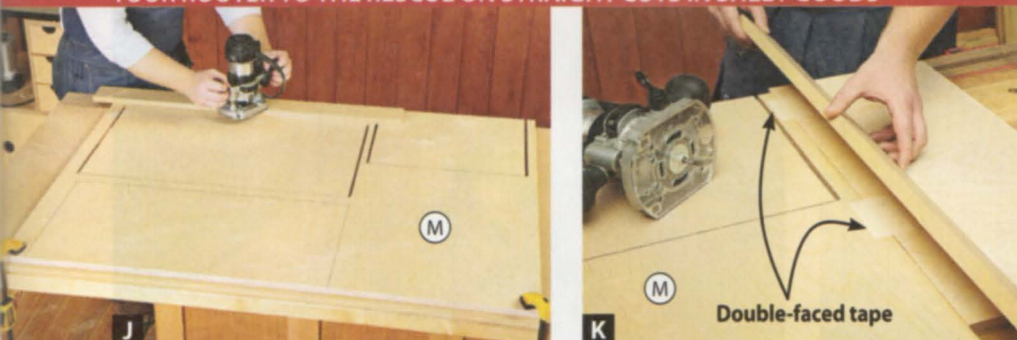

Place a sacrificial sheet (wood or extruded foam) under the cabinet sides (M) to protect your work surface from the through cuts. For cuts near edges, support the straightedge and buttress the thin area of the workpiece with a plywood scrap of identical thickness.

THE SIDES SKIN THE STAND



Working on one side at a time, glue the cabinet sides (M) in place. The cabinet sides create recesses for the filters and help seal the separator box (A-F).

3 CABINET ASSEMBLY

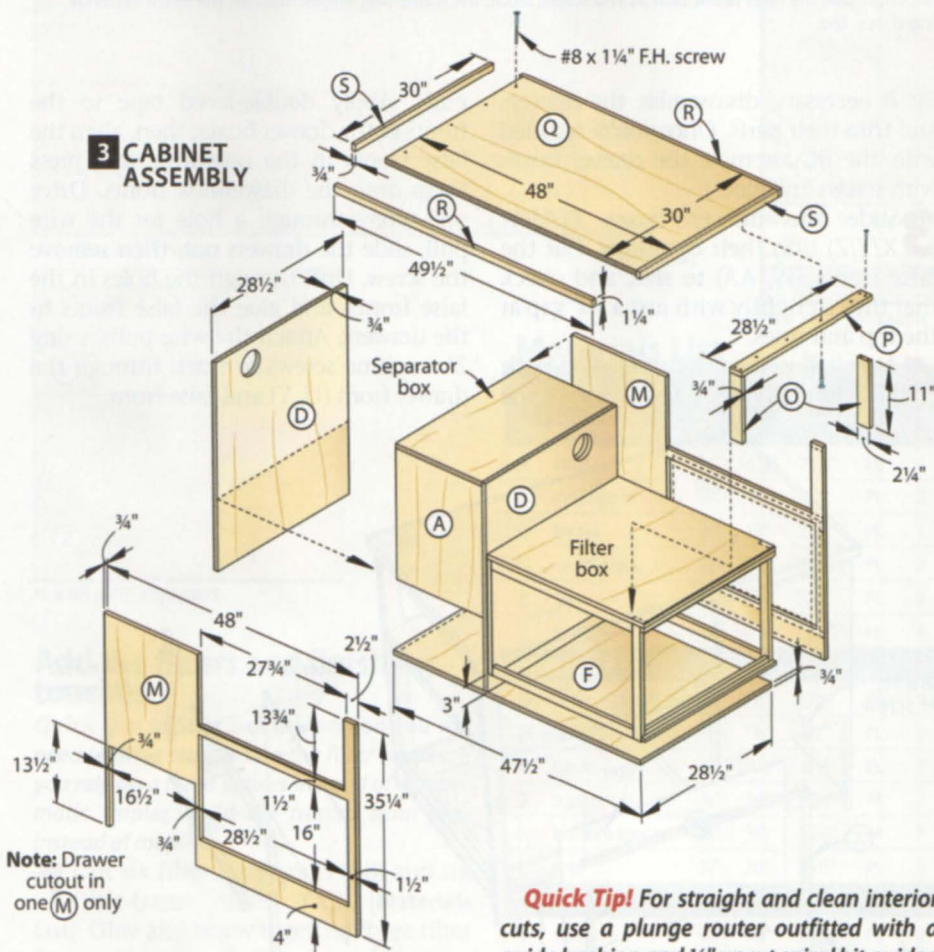

Note: Drawer cutout in one (M) only

(G/H/I) [Photo I]. Note: The bottom spacer rests $\frac{1}{4}$ " above the bottom edge of the horizontal cleat (H) to create a stop for the drawer front added later.

Add the sides, casters, dust collector, and top

1 Cut the cabinet sides (M) [Drawing 3]. The identically shaped sides mirror each other except that only one has a drawer cutout—something to keep in mind if one side of your plywood looks better than the other, and you want the good side facing out.

Quick Tip! For straight and clean interior cuts, use a plunge router outfitted with a guide bushing and $\frac{1}{4}$ " upcut spiral bit guided by a straightedge held in place with double-faced tape [Photos J and K].

2 Glue and clamp the cabinet sides (M) to the separator/filter-box assembly (A-L) [Photo L].

Quick Tip! Use a flush-trim bit in your router, if necessary, to trim the sides flush with other parts.

3 Using $\frac{1}{4}$ "x1" lag screws with washers, attach 3" locking swivel casters to the corners of the bottom (F). If the points of the screws stick into the drawer openings you will need to file or grind them flush.

MOUNT THE DUST COLLECTOR



Screw down one end of each motor mount (N). Slide the blower's flanges under the motor mounts' rabbets and attach the other ends of the mounts.

4 Next, attach a 5x4" quick coupler [Sources] to the exhaust port on the dust-collector blower.

Quick Tip! If the coupler fits loosely, adhere $\frac{1}{4}$ " foam tape onto the exhaust for an airtight friction fit.

Thread a 17" length of flexible 4" dust-collection hose [Sources] onto the quick coupler and attach a 4" connector to the opposite end of the hose using a 4" hose clamp. Run a 13" length of flexible hose between the connector on the separator box and the inlet of the dust-collector blower, securing both ends with 4" hose clamps. Position the blower so it rests entirely within the edges of the filter-box top (L). Bend the exhaust-port hose 90° and determine a mounting location for its connector. Cut a 4" hole at that location and attach the connector with 1" screws. Mark the location of the blower's mounting flanges; then remove the blower. Cut two rabbeted motor mounts (N) [Drawing 2], and secure the blower [Photo M].

5 Cut the two support stiles (O) and the support rail (P) to size [Materials

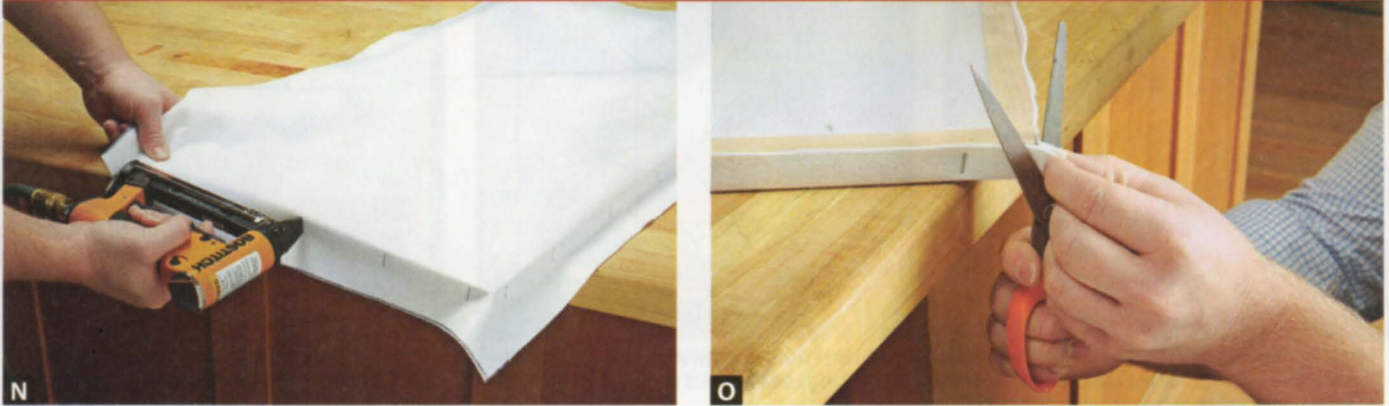

N Staple along one long edge of the filter frame (BB/CC) first. Then, pull the filter fabric taut as you staple along the remaining edges. Trim off the extra material along all edges before gathering the corners and trimming those, too. **O**

List, Drawing 3]. Glue the support stiles to the inside of the sides (M) and glue and screw the support rail atop the stiles.

6 Cut the top (Q), long edging (R), and short edging (S) [Drawing 3]. Glue the short edging to the top with one edge flush with the top surface. Using a hand-saw, carefully trim the edging's ends flush with the top and attach the long edging. Trim that edging flush with the short edging. Set the top in place and secure one end with 1/4" screws driven from the bottom of the support rail (P). Secure the other end of the top with screws driven through the top and into the separator box (A-E).

ily. If necessary, disassemble the drawers and trim their parts. Once you're satisfied with the fit, assemble the drawer boxes with screws and glue.

3 Slide the drawer boxes (T/U/V; X/Y/Z) into their openings. Cut the false fronts (W, AA) to size, and check that they fit tightly with just a 1/16" gap at the top and sides.

4 Attach 3" wire pulls centered on both false fronts (W, AA) then remove the

pulls. Apply double-faced tape to the fronts of the drawer boxes; then, align the false fronts in the openings, and press them onto the drawer-box fronts. Drive one screw through a hole for the wire pull, slide the drawers out, then remove the screw. Drill through the holes in the false fronts, and glue the false fronts to the drawers. Attach the wire pulls, using 2" machine screws to reach through the drawer front (U, Y) and false front.

Build and install the drawers

1 Cut the sides, fronts, backs, and bottoms for the separator drawer (T, U, V) and the filter drawer (X, Y, Z) [Drawing 4]. Temporarily assemble the boxes using 1/2" screws and attach the bottoms with 1" screws.

2 Test the fit of the drawer boxes (T/U/V; X/Y/Z) in their openings. They should be snug to minimize air leaks, but slide eas-

4 EXPLODED VIEW and FILTER FRAMES

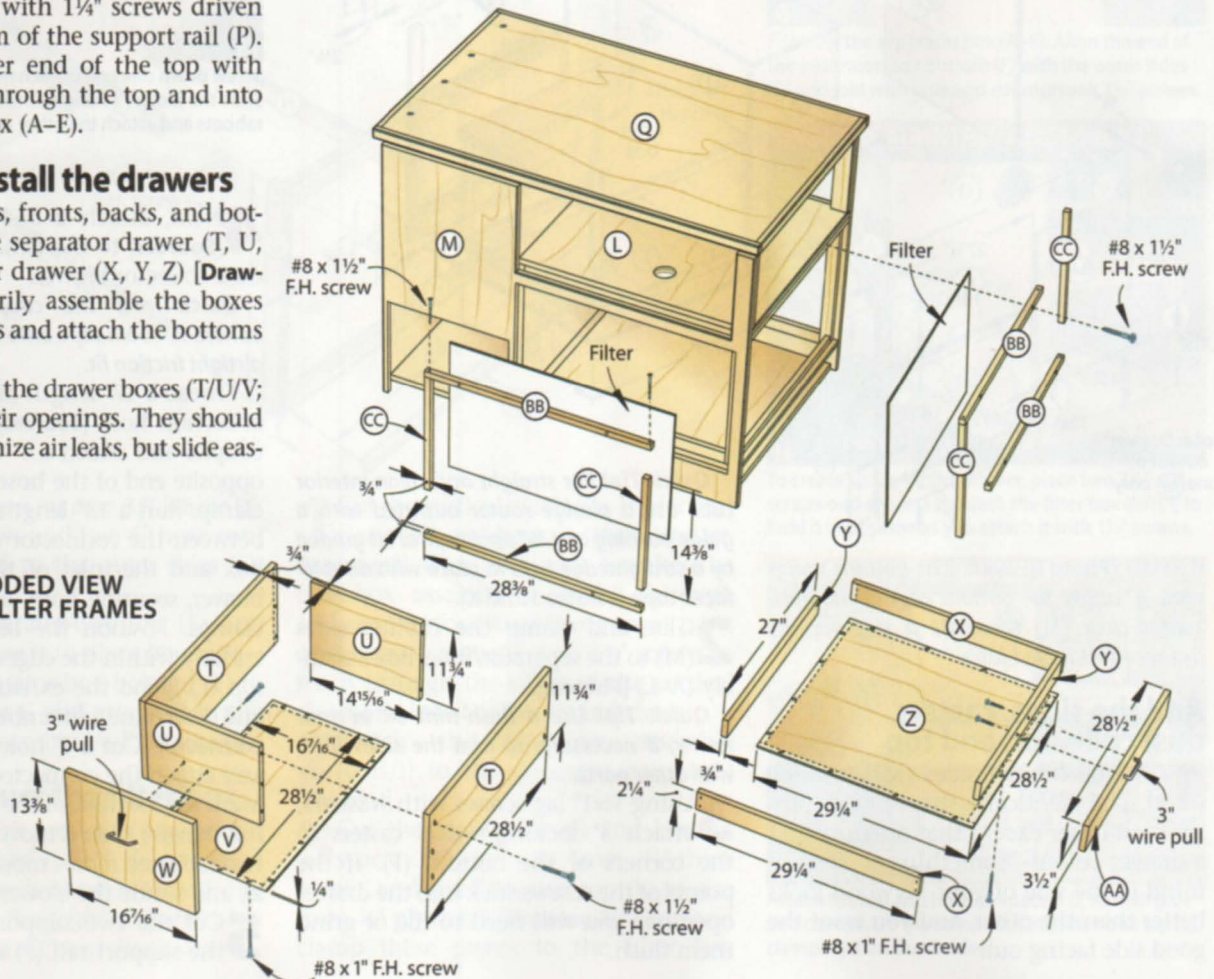

Cutting Diagram

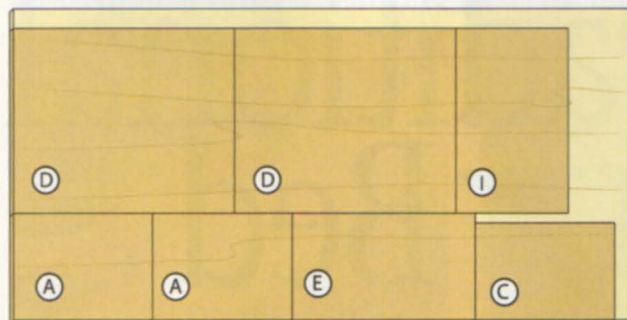

3/4 x 48 x 96" Plywood

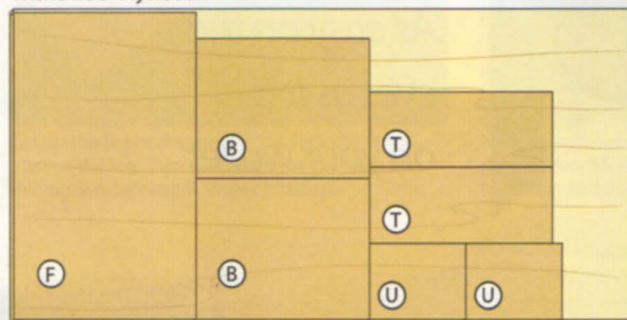

3/4 x 48 x 96" Plywood

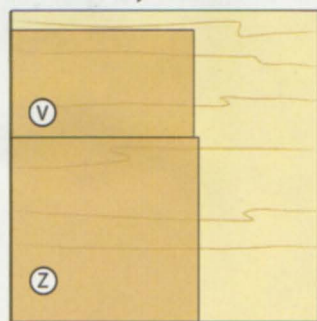

1/4 x 48 x 48" Plywood

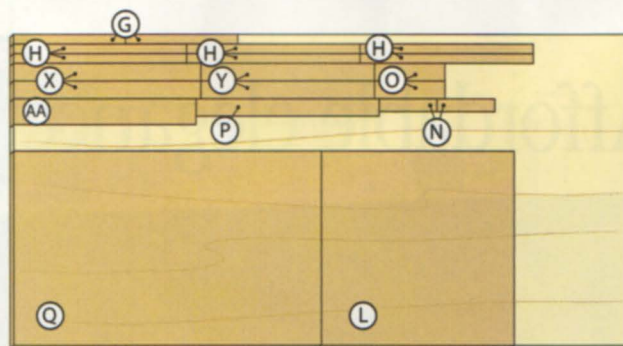

3/4 x 48 x 96" Plywood

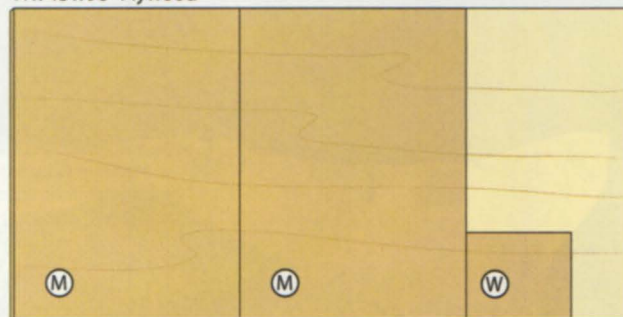

3/4 x 48 x 96" Plywood



3/4 x 7/4 x 96" Maple (5.3 bd. ft.)

Materials List

Part	FINISHED SIZE			Matl.	Qty.
	T	W	L		
Separator box					
A ends	3/4"	16 1/2"	21 3/4"	PL	2
B inner sides	3/4"	21 3/4"	27"	PL	2
C baffle	3/4"	15"	21 3/4"	PL	1
D outer sides	3/4"	28 1/2"	34 1/2"	PL	2
E top	3/4"	16 1/2"	28 1/2"	PL	1
F bottom	3/4"	47 1/4"	28 1/2"	PL	1
Filter box					
G vertical cleats	3/4"	1 1/2"	17 1/2"	PL	2
H horizontal cleats	3/4"	1 1/2"	27"	PL	6
I back	3/4"	28 1/2"	17 1/2"	PL	1
J top spacer	3/4"	3/4"	28 1/2"	M	1
K bottom spacer	3/4"	1/2"	28 1/2"	M	1
L top	3/4"	30"	28 1/2"	PL	1
Cabinet					
M sides	3/4"	48"	35 1/4"	PL	2
N motor mounts	3/4"	2"	9"	PL	2
O support stiles	3/4"	2 1/4"	11"	PL	2
P support rail	3/4"	2 1/4"	28 1/2"	PL	1
Q top	3/4"	30"	48"	PL	1
R long edging	3/4"	1 1/4"	49 1/2"	M	2
S short edging	3/4"	1 1/4"	30"	M	2

Part	FINISHED SIZE			Matl.	Qty.
	T	W	L		
Separator drawer					
T sides	3/4"	11 3/4"	28 1/2"	PL	2
U front & back	3/4"	11 3/4"	14 15/16"	PL	2
V bottom	1/4"	16 7/16"	28 1/2"	PL	1
W false front	3/4"	16 7/16"	13 7/16"	PL	1
Filter drawer					
X sides	3/4"	2 1/4"	29 3/4"	PL	2
Y front & back	3/4"	2 1/4"	27"	PL	2
Z bottom	1/4"	28 1/2"	29 3/4"	PL	1
AA false front	3/4"	3 1/2"	28 1/2"	PL	1
Filter frame					
BB rails	3/4"	3/4"	28 3/8"	M	6
CC stiles	3/4"	3/4"	14 3/8"	M	6

*Part length may vary depending on the size of your dust-collector blower.

Materials key: PL—plywood, M—maple.

Supplies: Double-faced tape, #8x1" flathead screws (52), #8x1 1/4" flathead screws (12), #8x1 1/2" flathead screws (128), #8x2 1/2" flathead screws (4), 3" wire pulls (2), #8-32x2" truss-head machine screws (4), 3" locking swivel casters (4), 1/4x1" lag screws (16), 1/4" washers (16), 1/2" staples. **Bits:** 3/4" drill bit; 1/4" upcut spiral, flush-trim router bits.

Sources

Dust-collection fittings: 4 1/2" flange elbows (2), no. D4223, \$5.95 each; 4" connectors (3), no. D4262, \$3.50 each; 5x4" quick coupler, no. D4233, \$2.95; 4" hose clamps (4), no. W1022, \$1.50 each; Grizzly Industrial, 800-523-4777, grizzly.com

Dust hose: 4"x10" clear flexible hose, no. D4206, \$15.95, Grizzly Industrial.

Dust collector: Model G0710, \$175, Grizzly Industrial.

Filter fabric: 36x82" 10-oz. polyester felt, singed one side, \$25, woodmagazine.com/filter.

Add the filters and finishing touches

Quick Tip! In Step 3 of this section you will need to drive staples into the filter frames. If you rely on a hand stapler instead of a pneumatic stapler, build the frames from pine instead of maple.

1 Cut six filter-frame rails (BB) and six filter-frame stiles (CC) [Materials List]. Glue and screw together three filter frames [Drawing 4]. Check to make sure they fit into their openings with 1/8" to spare all the way around.

2 Apply a durable finish to all surfaces. We applied three coats of a water-based polyurethane.

3 Cut three 21x32" pieces of filter fabric [Sources]. Staple those pieces to the filter frames [Photos N, O].

4 Place the filters within their openings with the fabric facing inward. Attach the frames with two countersunk 1 1/2" screws driven through each frame rail (BB).

5 Attach a length of flexible hose to the connector on the outside of the

separator box. Hook up the other end of the hose to any dust belcher in your shop and enjoy your new level of dust-collection efficiency. 🌳

Produced by **Bill Krier** with **John Olson**
Project design: **John Olson**
Illustrations: **Lorna Johnson**

Affordable elegance Traditional Bed

As easy on the eyes as it is on your wallet



When beginning a project, I often start at the end—or rather, at the finish. For this bedroom set, I wanted the warm look of aged cherry, while keeping lumber costs affordable. After experimenting with different stains and dyes on poplar, I came up with the color shown—but the process to achieve it was a bit cumbersome. A simple solution turned up at a paint store down the block. I took my sample to them and they custom-tinted a stain to match it, creating a one-step method for giving inexpensive poplar boards and ¼" maple plywood the look of cherry. (Find the formula on page 39.) Substituting this less-expensive stock reduced the lumber bill by \$100.

John Olson, Design Editor

Approximate materials cost: \$175
Dimensions: 54"H × 68¼"W × 85½"L

This bed is the first piece in a five-piece traditional bedroom set. In our next issue (219, July 2013), we'll provide plans for a nightstand and matching dresser; issue 220 (September 2013) will feature a lingerie chest; and issue 221 (October 2013) will have plans for a blanket chest.

Note: We sized the bed to accommodate a queen-size (60×80") box spring and mattress; other box-spring/mattress sets may vary in length and width, so have them on hand before you customize any bed dimensions.

Make the headboard and footboard parts

Quick Tip! These two assemblies share many of the same parts, so it makes sense to mill them at the same time to save on setups.

1 From three boards of ¾" poplar slightly wider and longer than the finished sizes shown in the **Materials List**, laminate blanks for the headboard legs (A) and footboard legs (B). Saw and plane the legs to finished size. Arrange the legs with the best faces toward the foot of the bed and mark them to keep straight their orientation.

SHOP TIP

You'll flip for this dead-centering trick

To quickly cut a perfectly centered $\frac{1}{4}$ " groove in the edge of a workpiece, set your tablesaw's fence to position the saw blade just to one side of dead center. Cut a kerf, flip the workpiece end-for-end, and cut another kerf. Check the fit of the plywood in the groove and adjust the fence if necessary. If you use a thin-kerf blade (with teeth less than $\frac{1}{8}$ " wide), you may need to adjust the fence and make a third cut to remove the middle material. Use a featherboard to ensure consistent cuts, and always test your setup in scrap before cutting the actual workpieces.

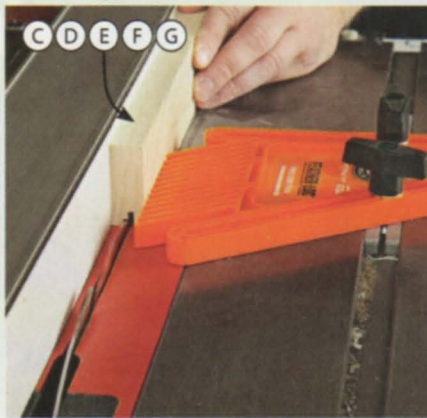

GANG PIECES FOR PRECISE LAYOUT

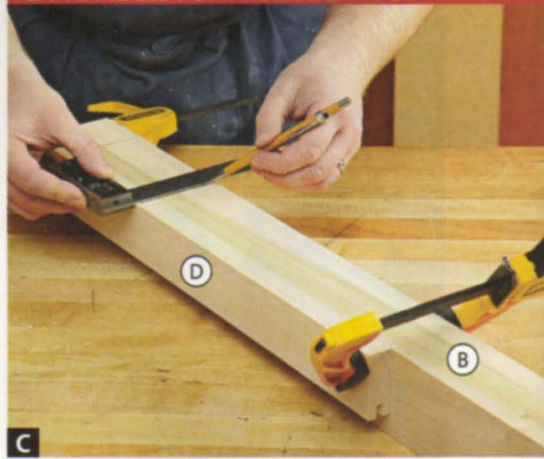

C To match the locations of mortises on mating workpieces, clamp them together and mark the locations using a square and sharp pencil.

5 Lay out the taper on the bottom inside face of each leg [Drawing 1]. Cut the tapers with your bandsaw; then, flatten the sawn edge with a sanding block or block plane.

6 Rout or sand $\frac{1}{8}$ " round-overs along the long and bottom edges of the legs.

7 From $\frac{3}{4}$ " poplar, cut to size the headboard outer stiles (C), footboard outer stiles (D), headboard and footboard rails (E), headboard inner stiles (F), and foot-

board inner stiles (G) [Materials List, Drawing 4]. In one edge of parts C, D, and E and in both edges of parts F and G, mill a centered $\frac{7}{16}$ "-deep groove to accept your $\frac{1}{4}$ " maple plywood, cut to size

8 From $\frac{1}{4}$ " maple plywood [Shop Tip, above], mill the headboard panels (H) and footboard panels (I) [Drawing 4]. Sand them to 220 grit. **Note:** You could substitute birch plywood for the panels, but whatever you choose, make sure it looks good on both sides.

outer stiles (C, D). We prefer to do this at the tablesaw using a dado set, but you could do it on a router table equipped with a straight bit, too.

2 Using Drawing 1 as a guide, mark the centerlines of the mortises in the legs (A, B) and outer stiles (C, D) [Photo C].

3 Build the self-centering router mortising jig described in the article on pages 50–53, and use it to rout centered $\frac{5}{16} \times 1\frac{1}{2}$ " mortises 1" deep in parts A–D [Drawing 1a]. Make 20 $\frac{5}{16} \times 1\frac{1}{2} \times 1\frac{7}{8}$ " loose tenons using the tools and methods also described in that article.

4 Glue the loose tenons into the outer stiles (C, D); then glue and clamp the legs (A, B) to these assemblies.

2 LEG FASTENER DETAIL

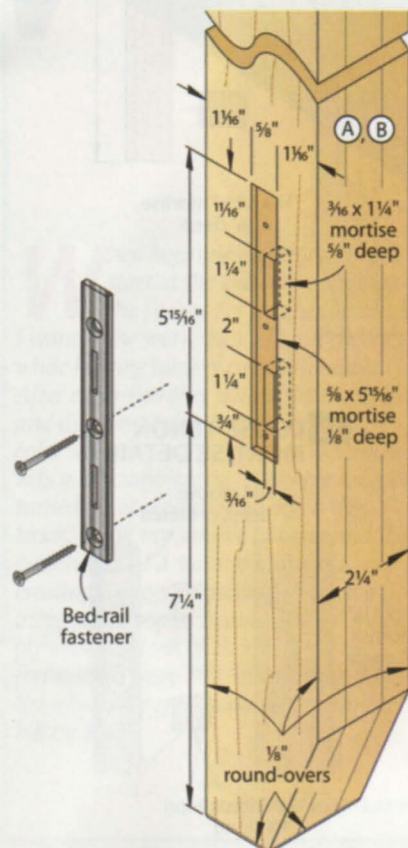

Cut the loose-tenon joints

1 On the ends of the headboard and footboard rails (E) and inner stiles (F, G), cut centered stub tenons [Drawing 3] that fit snugly in the grooves in the

3 STUB-TENON DETAILS

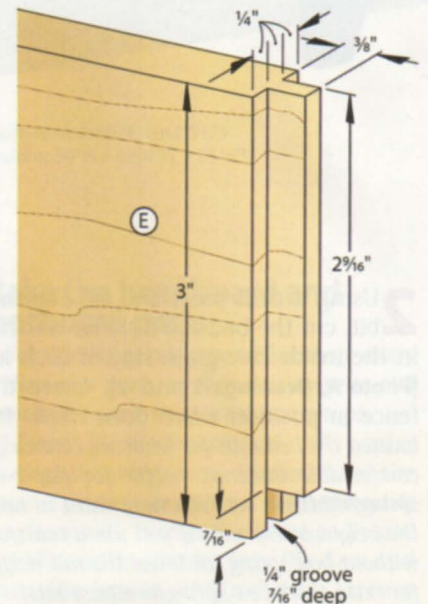
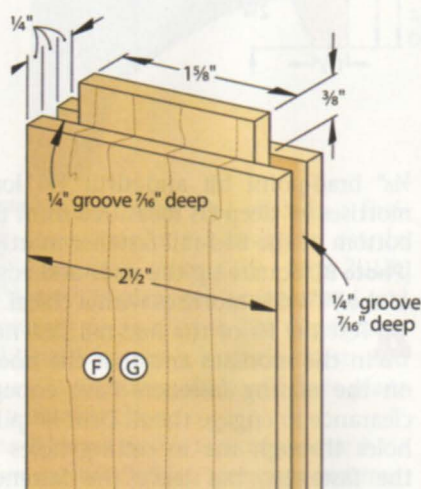

SHOP TIP

Turn two pipe clamps into one really long clamp

Few of us have clamps long enough to pull together the wide footboard and headboard. But you can "make" a clamp that will handle the job. Simply join two 3' pipe clamps with a threaded coupler, as shown. Repeat with two more clamps. Place $\frac{3}{4}$ "-thick spacer blocks above and below the middle of the footboard and headboard assemblies, as shown, to support the assemblies and the pipe clamps as the glue dries.

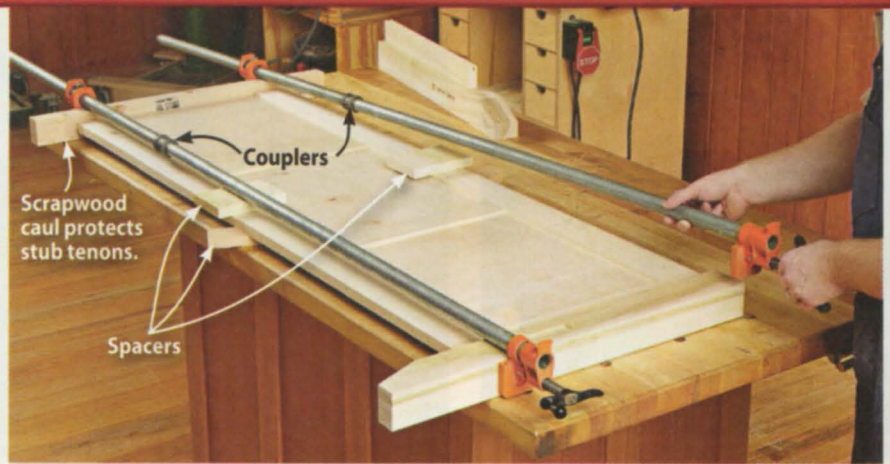

Assemble the footboard and headboard

- 1** Glue and clamp the footboard inner stiles (G) to the lower footboard rail (E), spacing them so the footboard panels (I) will slip into place in the next step [Drawing 4].
- 2** Glue the footboard panels (I) to the rail-and-inner-stiles assembly (E/G).
- 3** Next, glue and clamp the upper footboard rail (E) to the footboard panels (I) and inner stiles (G).
- 4** To the E/G/I assembly, glue and clamp the leg/footboard outer-stile assemblies (B/D), as shown in the **Shop Tip** above.

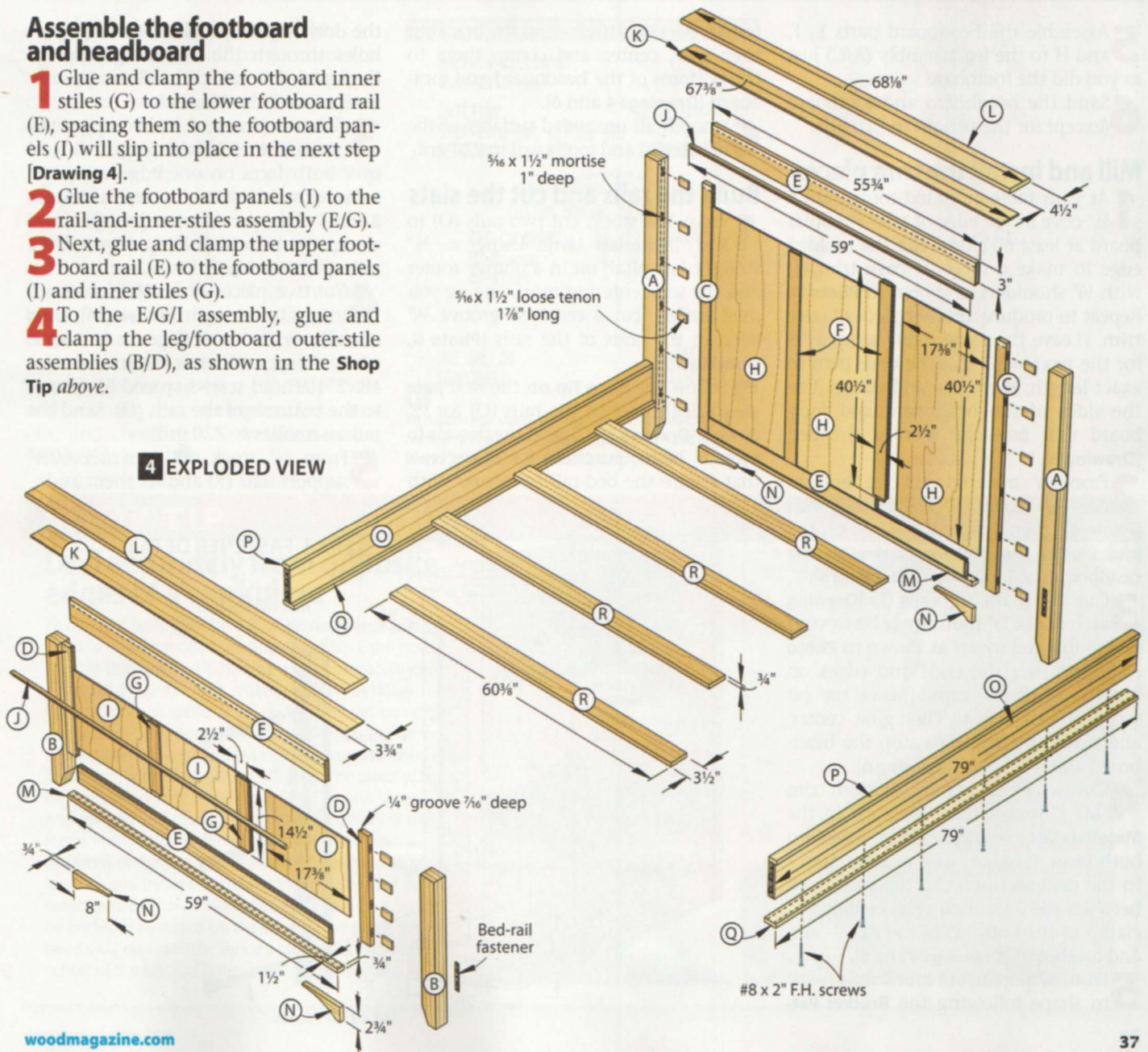

RIP THE COVE TRIM

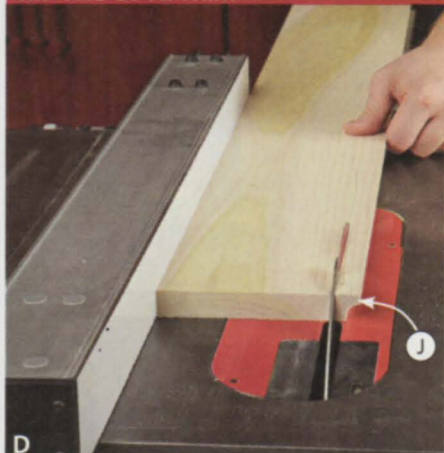

D For the cleanest and safest results, rout and rip the cove trim (J) from a board that starts out at least 4" wide.

SUPPORT YOUR END CUTS



E Clamp a support board in a nearby bench vise or to a sawhorse to hold the bottom cap (K) level with the router table when routing the ends.

SET UP THE ROUND-OVER BIT



F Adjust the top of the bit's cutting edge $\frac{5}{16}$ " above the router table prior to rounding over the top caps (L) and panel-bottom trim (M).

5 Assemble the headboard parts E, F, and H to the leg assembly (A/C) just as you did the footboard.

6 Sand the headboard and footboard (except for the panels) to 220 grit.

Mill and install the trim pieces

1 At your table-mounted router, cut a $\frac{1}{2}$ " cove in the edge of a $\frac{3}{4}$ " \times 4" poplar board at least 60" long. Rip the molded edge to make a piece of cove trim (J) with $\frac{1}{4}$ " shoulders as shown in **Photo D**. Repeat to produce another piece of cove trim. (Leave the router-table setup as is for the next step.) Cut the cove trim to exact length; then glue and clamp it to the sides of the headboard and footboard that face the foot of the bed [**Drawing 6**].

2 From $\frac{3}{4}$ " material, cut the bottom caps (K). Rout $\frac{1}{2}$ " coves in their ends [**Photo E**], then the edges. Glue, center, and clamp the bottom caps atop the headboard and footboard [**Drawing 6**].

3 Cut to size the top caps (L) [**Drawing 4**]. Install a $\frac{1}{2}$ " round-over bit in your table-mounted router as shown in **Photo F**. Round over the ends and edges on both faces of the caps. (Leave the bit setup as is for **Step 4**.) Then glue, center, and clamp the top caps atop the headboard and footboard [**Drawing 6**].

4 Cut two pieces of panel-bottom trim (M) 1" longer than specified in the **Materials List**. Round over the edges on both faces. (Leave the bit as is for **Step 3** in the next section.) Cut the trim to fit between the legs; then glue, center, and clamp to the bottoms of the headboard and footboard [**Drawings 4 and 6**].

5 From $\frac{3}{4}$ " poplar, cut four brackets (N) to shape following the **Bracket Pat-**

tern on page 40. Finish-sand the brackets; then glue, center, and clamp them to the bottoms of the headboard and footboard [**Drawings 4 and 6**].

6 Smooth all unsanded surfaces of the headboard and footboard to 220 grit.

Build the rails and cut the slats

1 From $1\frac{1}{4}$ " stock, cut two rails (O) to size [**Materials List**]. Using a $\frac{5}{8}$ " straight (or spiral) bit in a plunge router and the self-centering mortising jig you used earlier, cut a centered groove $\frac{1}{8}$ " deep in the ends of the rails [**Photo G, Drawing 5**].

2 Follow the **Shop Tip** on the next page to drill holes in the rails (O) for $\frac{1}{2}$ " dowels [**Drawing 5**]. Glue in the dowels to provide better purchase for the screws that secure the bed-rail fasteners. With

the dowels glued in place, drill $\frac{1}{8}$ " pilot holes through the mounting holes in the bed-rail fasteners, but leave the fasteners unattached for now.

3 Cut two pieces of $\frac{3}{4}$ " \times 1 $\frac{1}{2}$ " rail trim (P) to finished length. Round over both faces on one edge using the same $\frac{1}{2}$ " round-over bit setup as in **Steps 3 and 4** of the previous section. Glue and clamp the trim to the top edges of the rails (O) [**Drawing 5**].

4 Cut two pieces of $\frac{3}{4}$ " \times 2 $\frac{3}{8}$ " lower rail trim (Q) to length [**Drawing 4**]; then round over the outer edges as in **Step 3**. Glue, clamp, and screw the trim—using #8 \times 2" flathead screws spaced 8" apart—to the bottoms of the rails (O). Sand the rail assemblies to 220 grit.

5 From $\frac{3}{4}$ " stock cut four $3\frac{1}{2}$ " \times 60 $\frac{3}{8}$ " support slats (R) and set them aside.

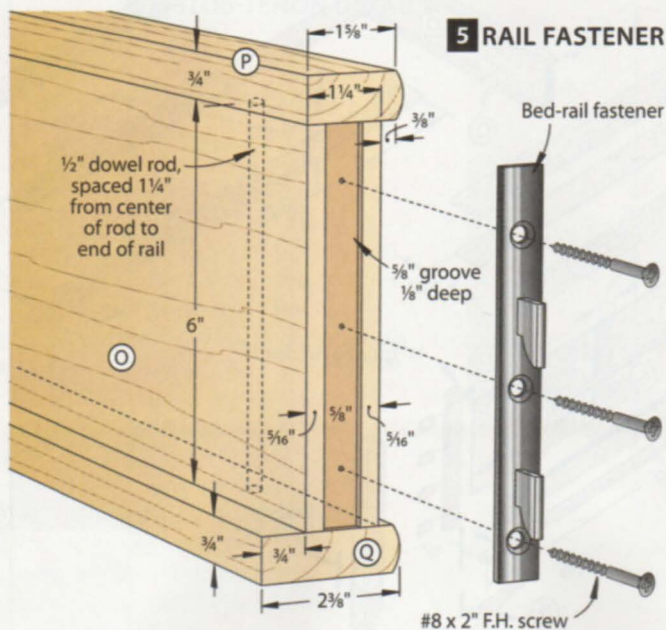

5 RAIL FASTENER DETAIL

CUT GROOVES IN THE RAIL ENDS

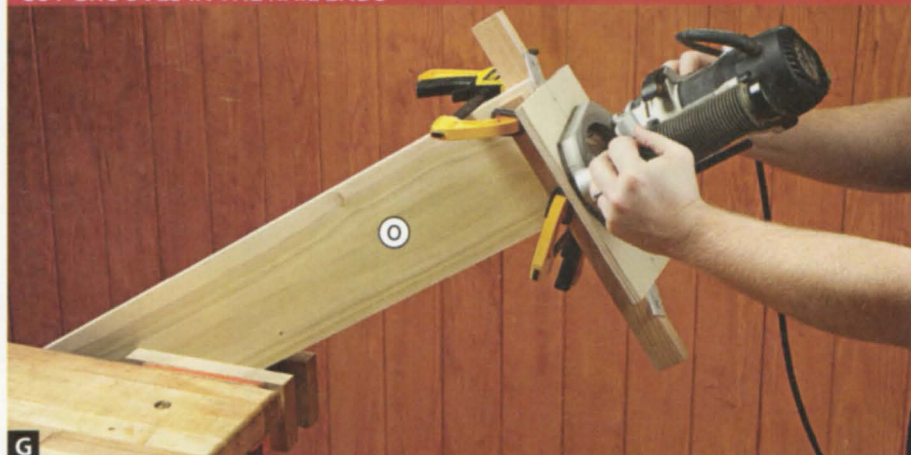

G Secure each rail at a comfortable working angle and rout bed-rail-fastener grooves in both ends using the jig from page 52. Because the mortising slot has a fixed length, you'll step-and-repeat to form the groove.

Apply finish and assemble

1 Apply a stain to all parts except the support slats (R). To simulate aged cherry we used Sherwin-Williams BAC Wiping Stain in a chestnut base with the custom tinting shown in **Photo H**.

2 To protect the wood, apply three top coats. (We used Old Masters satin brushing lacquer.)

3 Screw the bed-rail fasteners to the rails, headboard, and footboard with #8x2" flathead screws. Hook the rails' bed-rail fasteners into the mating fasteners on the headboard and footboard. Add the support slats (R), spaced evenly atop the lower rail trim (Q). Top it all with a comfy box spring/mattress, linens, and comforter. Now take a rest—you've earned it! 🌲

CUSTOM TINTS GIVE THE COLOR

SHERWIN-WILLIAMS
Sher-Color (tm)

INTERIOR	PROFESSIONAL
SHER-WOOD BAC WIPING STN	ALKYD
PENETRATING	STANDALONE

WOOD MAGAZINE
CUSTOM MANUAL MATCH

BAC COLORANT	OZ	32	64	128
R2-Maroon	2	36	-	-
B1-Black	-	52	-	-

ONE GALLON
S64ND0051

CHESTNUT
501246219

H To match our stain, simply show this photo to the clerk at a Sherwin-Williams store and have him blend your finish to these specifications.

6 FOOTBOARD ASSEMBLY SECTION VIEW

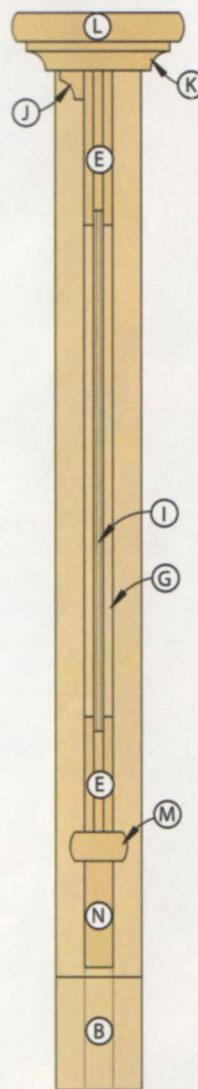

SHOP TIP

Drill accurately from opposite edges of a workpiece

To drill a 1/2" hole through a 6"-wide workpiece you'll need to drill from opposite edges and have the holes meet in the middle. Doing that requires an accurately adjusted drill press. First, make sure it bores holes exactly 90° to its table. Then, chuck in a brad-point bit and set the drill-press-table fence to center the bit on the thickness of a scrap of the same thickness as a bed rail. To do this, with the machine off, press the point of the bit into the edge of the scrap piece. Turn the scrap end-for-end and place the opposite face against the fence. Plunge down the bit again and check the positions of the two indentations. Tweak the fence location and try again until the indentations fall in the same spot, as shown. Now that you know your bit will be perfectly centered on the edge of the stock, you need only clamp to the fence a stopblock 1/4" from the center of the bit. The holes will line up precisely.

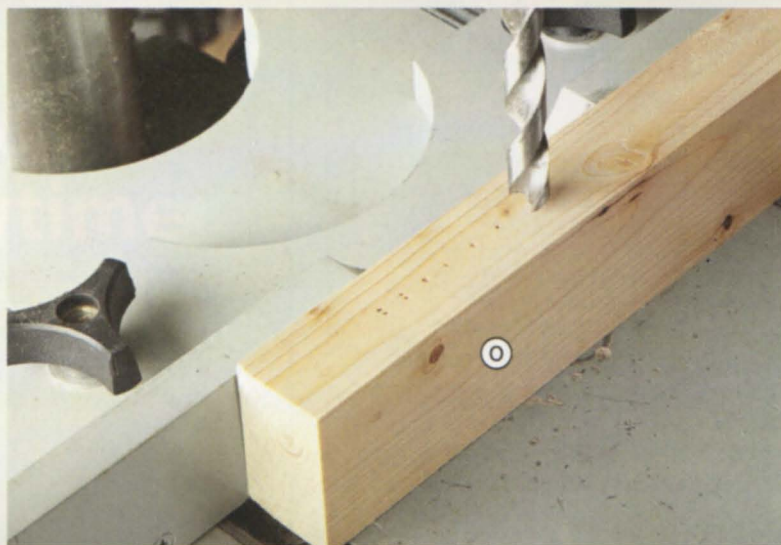

Materials List

Part	FINISHED SIZE			Matl.	Qty.	
	T	W	L			
A	headboard legs	2¼"	2¾"	52½"	LP	2
B	footboard legs	2¼"	2¾"	26½"	LP	2
C	headboard outer stiles	¾"	2"	45¾"	P	2
D	footboard outer stiles	¾"	2"	19¾"	P	2
E	headboard and footboard rails	¾"	3"	55¾"	P	4
F	headboard inner stiles	¾"	2½"	40½"	P	2
G	footboard inner stiles	¾"	2½"	14½"	P	2
H	headboard panels	¼"	17¾"	40½"	MP	3
I	footboard panels	¼"	17¾"	14½"	MP	3
J*	cove trim	¾"	¾"	59"	P	2
K	bottom caps	¾"	3¾"	67¾"	P	2
L	top caps	¾"	4½"	68½"	P	2

Part	FINISHED SIZE			Matl.	Qty.	
	T	W	L			
M*	panel bottom trim	¾"	1½"	59"	P	2
N	brackets	¾"	2¾"	8"	P	4
O	rails	1¼"	6"	79"	P	2
P*	upper rail trim	¾"	1¾"	79"	P	2
Q	lower rail trim	¾"	2¾"	79"	P	2
R	support slats	¾"	3½"	60¾"	P	4

*Parts initially cut oversize. See the instructions.

Materials key: LP—laminated poplar, P—poplar, MP—maple plywood.

Supplies: #8x2" F.H. screws (24), ½x24" dowel.

Bits: ¾" and ½" brad-point bits; ¾" Forstner bit; ½" cove, ⅛" and ½" round-over, ⅝" straight or spiral, and ⅝" upcut spiral or straight router bits.

Source

Bed-rail fasteners: 6x⅝" heavy-duty wrought steel bed-rail fastener set, no. 28597, \$15.39, Rockler Woodworking and Hardware, 800-279-4441, rockler.com.

More Resources

- ▶ Find more bed plans for a small fee at woodmagazine.com/beds.
- ▶ Learn more about poplar at woodmagazine.com/poplar.
- ▶ Need to stock up on long clamps? Read our shop-tested reviews at woodmagazine.com/clampreviews.

Cutting Diagram

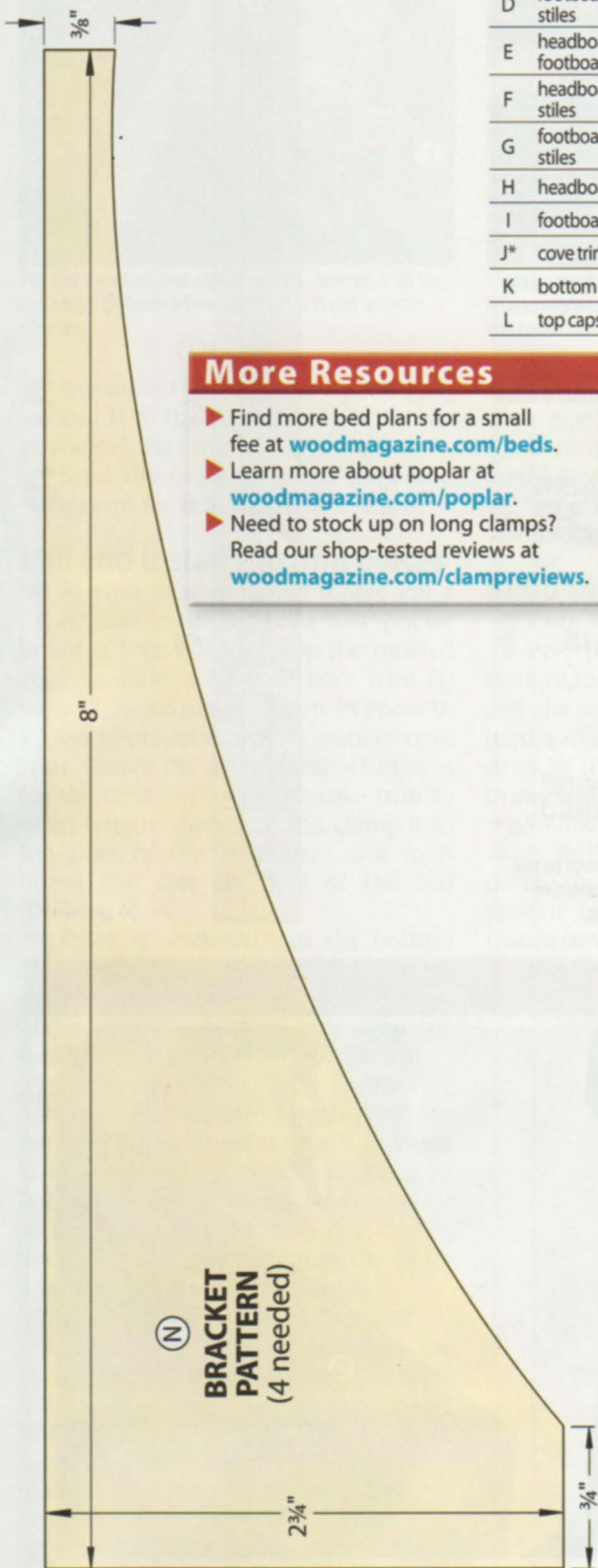
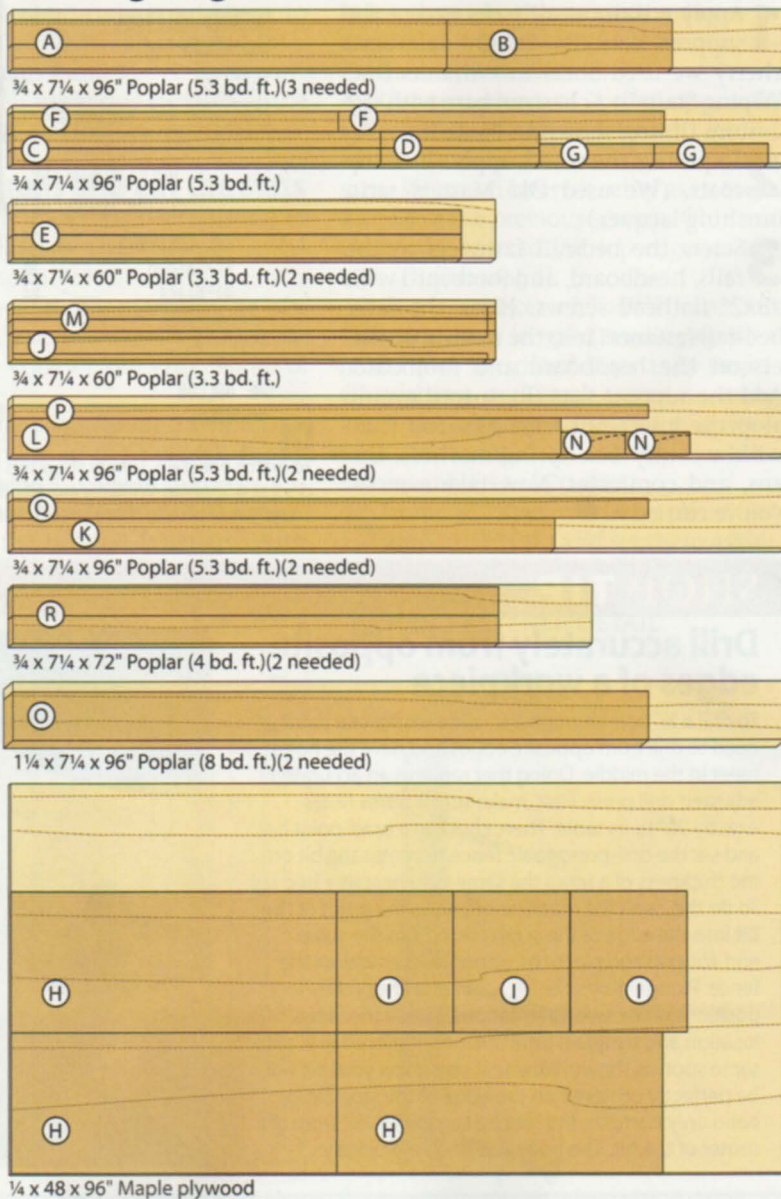

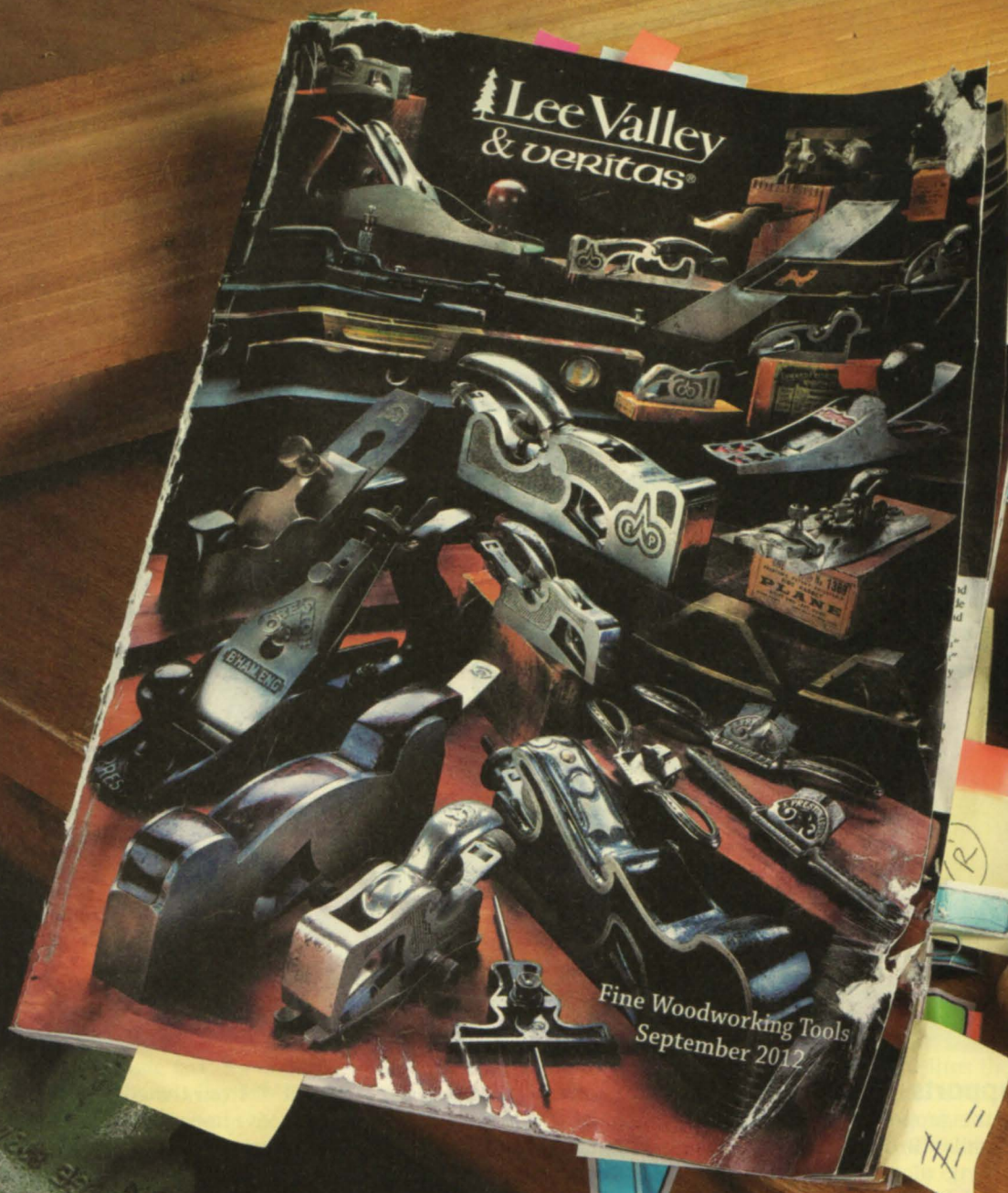

The first tool you reach for everytime

Our woodworking tools catalog is the original product app. It is designed to help the woodworker perform a specific task – find workshop solutions, 24/7.

With our large selection of high-quality hand tools, woodworking supplies, power tool accessories, and our innovative Veritas® line of products bundled together in one handy reference, our user-friendly and informational catalog is always ready to use. A quick flip through the pages conveys a sense of scope, while also allowing for rapid visual comparison. You can even use a colored flag, dog-ear fold, gum wrapper or ticket stub to bookmark your favorites for later retrieval.

Request a copy of our free 284-page catalog or browse it online.

1-800-683-8170
www.leevalley.com

 **Lee Valley**

Sofa Server

Keep beverages, snacks, and the remote nearby while you take in the big game or your favorite show.

Dimensions: 14"W x 18 $\frac{3}{8}$ "D x 24"H
Approximate lumber cost: \$18

Start with the supports

1 Begin by cutting the support stiles (A) and support rails (B) to size [Materials List, Drawing 1], along with two scraps the same thickness to help

with router-table setups. Mount a $\frac{1}{4}$ " spiral upcut or straight bit in your router table, and position the fence to center the bit on the thickness of your scrap piece. Attach a stopblock to the router

fence $1\frac{1}{2}$ " from the edge of the bit and cut a groove in one of the scraps to verify your setup [Photo A]. Then, rout the stopped mortises on the edge of the support stiles [Drawing 2].

ROUT A TEST MORTISE FIRST

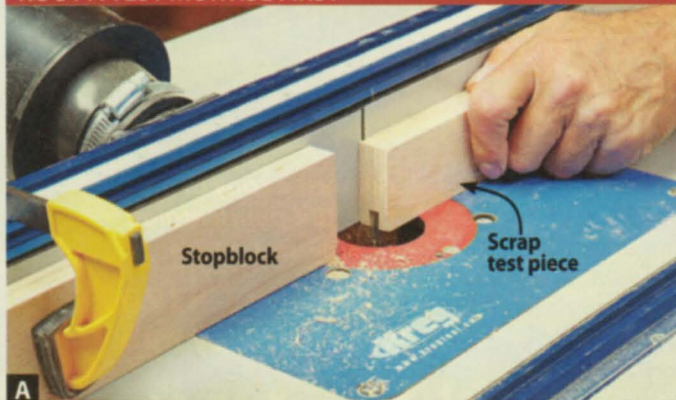

A Clamp a stopblock to your router-table fence to ensure you cut each stopped mortise to a consistent length. Check the setup on scrap pieces.

BACKER PREVENTS TEAR-OUT ON RAILS

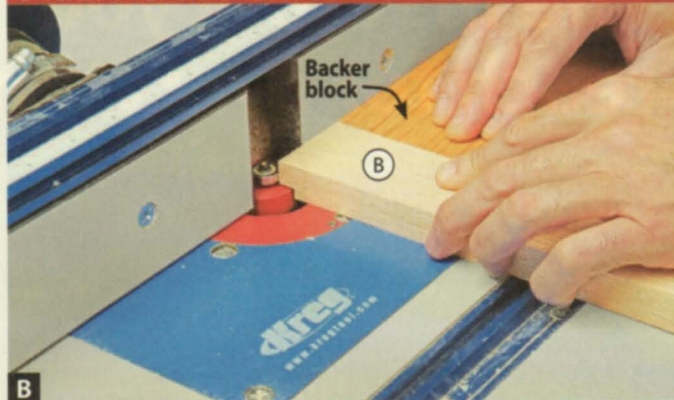

B To steady narrow workpieces such as this support rail (B) and prevent tear-out on susceptible end grain, guide the workpiece with a backer block.

SHOP TIP

A rabbeting bit trumps saw blades for clean cuts

Although you can cut all the tenons in this project with a standard or dado blade in your tablesaw, a rabbeting bit leaves behind a cleaner surface. You can easily change the tenon length by swapping the guide bearing. Use a large-diameter bearing for short tenons; smaller bearings for longer ones. A small cap screw, secured with a hex key, holds the bearing in place.

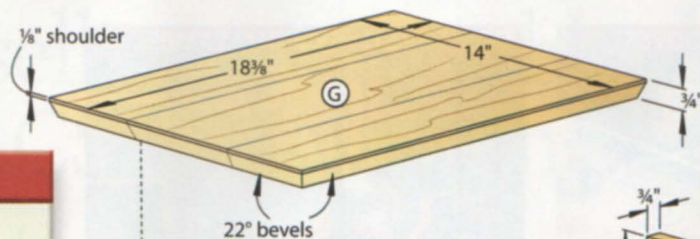

1 EXPLODED VIEW

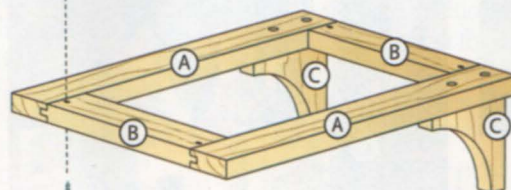

#8 x 1 1/4" F.H. screw

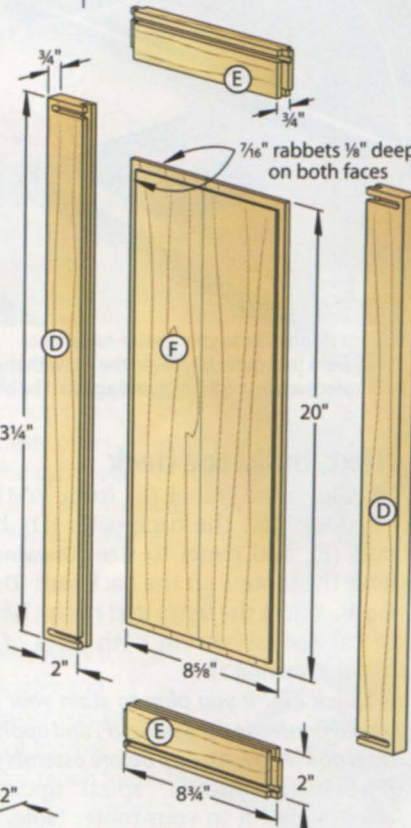
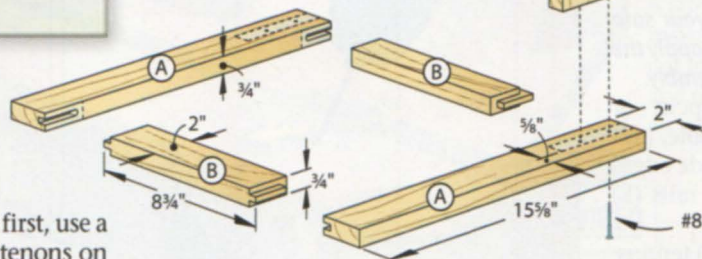
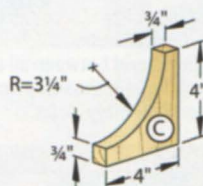

2 Testing your setup on scrap first, use a 3/8" rabbeting bit to cut the tenons on the ends of the support rails (B) [Photo B, Shop Tip above]. Make your first pass with the bit set 1/4" above the table; then make a cut on the opposite face, leaving a 1/4"-thick tenon. Bandsaw away 3/8" of each tenon's bottom edge [Drawing 2].

3 Glue up the two support frames (A/B). After the glue dries, rout two 3/8" rabbets along one end of both sup-

port frames [Photo C, Drawing 2]. Bandsaw away 3/8" of this tenon on both ends of the support frames.

4 From 3/4" stock, cut four 4x4" blanks for the braces (C). Place the point of a compass on a corner of one blank and lay out a 3 1/4" radius [Drawing 1]. Repeat

for the other three braces. Bandsaw just outside the line; then, sand to the line.

5 Orient the braces with the end grain against the support stile (A); then, glue and screw the braces to the support frames (A/B) centered and flush with the shoulder of the tenon.

MAKE A PASS, FLIP, AND CUT AGAIN



Employ the same tenon-cutting technique used on the ends of the support rails (B) to form a tongue along one short edge of both support frames (A/B).

2 TOP AND BOTTOM SUPPORT

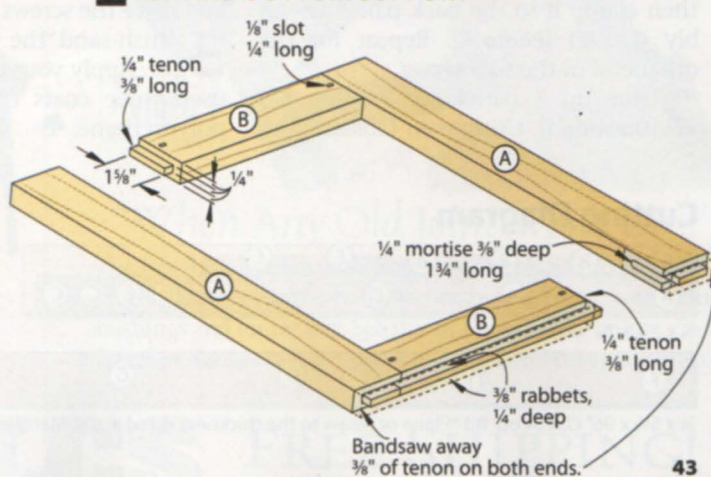

CUT PRECISE STOPPED GROOVES



D Clamp stopblocks to your router-table fence $11\frac{3}{8}$ " from the router bit. Begin the cut with the workpiece against one stop; end against the other.

Next, build the back

1 Glue up a panel (F) from $\frac{1}{2}$ "-thick stock. Cut the back stiles (D), back rails (E), and panel to size [Drawing 1]. Rout the tenons on the back rails [Drawing 3]. Adjust the fence and the bit height to cut the rabbets on both faces of the panel [Drawing 1].

Quick Tip! If you plan to stain your sofa server, finish-sand the panel (F) and apply the stain now. Allow it to dry before assembly.

2 Reinstall the $\frac{1}{4}$ " spiral upcut or straight bit in your router table, and cut grooves centered on the inside edges of the back stiles (D) and back rails (E) [Drawing 3].

3 Apply glue to the back rail (E) tenons; then, assemble the back panel assembly (D/E/F). Don't get glue on the panel during assembly; it should float freely inside the frame.

4 After the glue dries, rout the stopped grooves in the back panel assembly (D/E/F) [Photo D, Drawing 3].

Assemble and finish the server

1 Apply glue along a support frame (A/B) tongue and brace (C) edge; then clamp it to the back panel assembly (D/E/F) [Photo E]. Repeat for the other end of the sofa server.

2 Glue up a panel for the top (G) [Drawing 1]. Using your tablesaw, cut

DON'T BE STINGY WITH CLAMPS



E To ensure a firm bond between all the assembled parts, apply clamping pressure to multiple points on the support assembly (A/B/C).

ROCK THAT DRILL BIT



F The top will expand and contract with seasonal humidity change. So create room for the screws to move by rocking the bit when drilling pilot holes.

22° bevels on all four edges, leaving a $\frac{1}{8}$ " shoulder at the top. Sand away machining marks, drill holes for the top in the upper support assembly (A/B) [Photo F], and drive the screws to install the top.

3 Finish-sand the sofa server to 220 grit. Apply your choice of finish. We used three coats of satin water-based polyurethane. 🌱

3 BACK PANEL ASSEMBLY

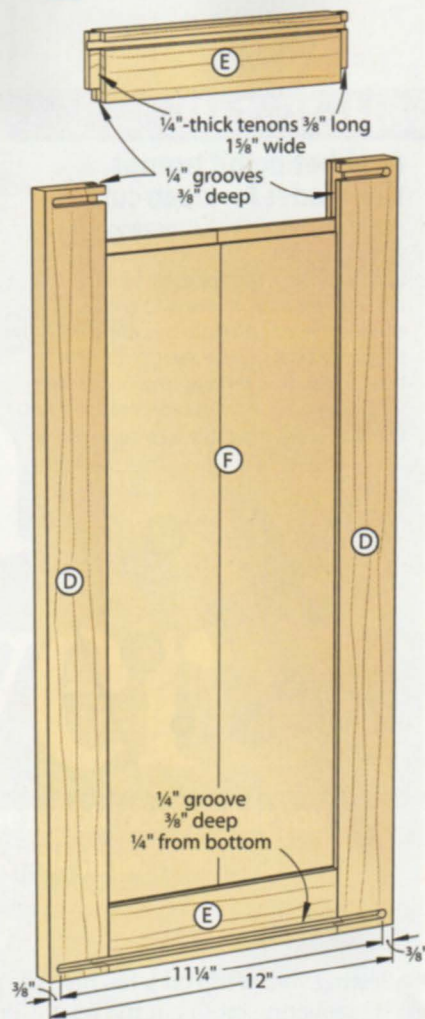

Produced by Nate Granzow with Brian Bergstrom
Project design: Kevin Boyle
Illustrations: Lorna Johnson

Materials List

Part	FINISHED SIZE			Matl.	Qty.
	T	W	L		
A support stiles	$\frac{3}{4}$ "	2"	$15\frac{3}{8}$ "	O	4
B support rails	$\frac{3}{4}$ "	2"	$8\frac{3}{4}$ "	O	4
C braces	$\frac{3}{4}$ "	4"	4"	O	4
D back stiles	$\frac{3}{4}$ "	2"	$23\frac{1}{4}$ "	O	2
E back rails	$\frac{3}{4}$ "	2"	$8\frac{3}{4}$ "	O	2
F panel	$\frac{1}{2}$ "	$8\frac{3}{8}$ "	20"	EO	1
G top	$\frac{3}{4}$ "	14"	$18\frac{3}{8}$ "	EO	1

Materials key: O—oak, EO—edge-glued oak.
Supplies: #8x $1\frac{1}{4}$ " flathead screws (12).
Bits: $\frac{1}{4}$ " straight or spiral upcut bit, rabbeting bit.

Cutting Diagram

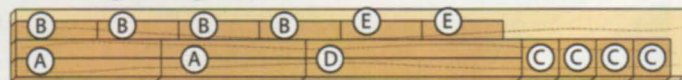

$\frac{3}{4}$ x $7\frac{1}{4}$ x 72" Oak (4 bd. ft.)

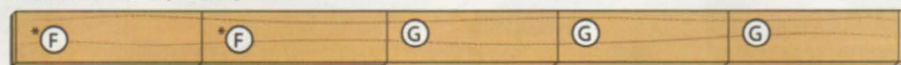

$\frac{3}{4}$ x $5\frac{1}{2}$ x 96" Oak (4 bd. ft.) *Plane or resaw to the thickness listed in the Materials List.

More Resources

► For free tips on mastering glue-ups, see woodmagazine.com/glueuptricks.

See our top selling router tables, bits & jigs at MLCSwoodworking.com

"Cabinet Making Set"

Six 1/2" shank carbide tipped router bits make classic kitchen and fine furniture cabinet raised panels and drawers.

Undercutter #8389...\$119.95
Standard #8387...\$114.95



"Don't Stand Stock On Edge"

Rout wide stock FLAT on the table with tall bits in horizontal position! The Horizontal Benchtop Router Table is perfect for raised panels and mortise and tenon. The miter T-track accepts accessory tops.

#9767.....\$179.95

"Tilting Top"

Accessory top tilts up to 45°. Create offset angles that cannot be cut on regular table.

#9764.....\$59.95



"Mortising Top"

Accessory top. A safer and easier way to cut mortise and tenon joints.

#9766.....\$79.95



"Route 66"

66 piece carbide tipped router bit set includes straight, round over, chamfer, cove... 30 total profiles! Wood storage box can be wall mounted.

1/2" shank • #8383.....\$189.95
1/4" shank • #6083.....\$189.95



"Sliding Table Top"

Free Shipping! The Precision Router Table's large, smooth sliding aluminum top makes difficult routing easy and exact. Variable opening inserts in "rock solid" fixed cast-iron. Split fence & dust hood.

#9463\$469.95

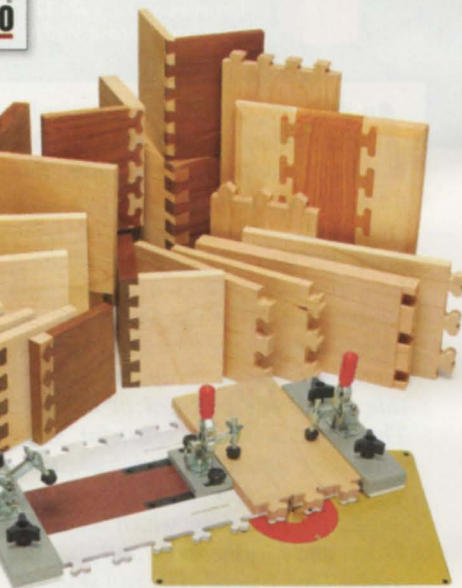

"When Any Old Joint Won't Do..."

The Fast Joint System with matching templates makes creative, custom joinery simple. Includes the jig, joint templates, clamps, bushings and router bits. See the 20 Template Set online.

4 Template Set #9411.....\$169.95 • 11 Template Set #9422.....\$269.95



1-800-533-9298
PROFESSIONAL ROUTER BITS & WOODWORKING PRODUCTS

MLCS

FREE SHIPPING!
IN CONTIGUOUS USA • P.O. BOX 165 DM, HV, PA, 19006 *2012

Raised Planter



Add interest to your landscaping by elevating a few plants, and make it easy to tend them without bending over.

Dimensions: 59 $\frac{3}{4}$ "W x 32 $\frac{1}{4}$ "D x 37"H
Approximate cost: \$170 for cedar lumber; \$24 for screws

In designing this project I noticed a trend among commercially made raised planters: Most have four thick, sturdy legs, with a box built around them. The legs eat up space inside the box, and having them inset from the sides makes a planter look top-heavy. So I moved the legs to the corners outside the box. For added elegance, trim makes it appear that the side boards are captured in a frame. The trim, along with careful screw placement, also hides the screwheads.

I used 5/4 cedar decking for everything except the legs, which are 4x4s. Cedar and weather-resistant glue (we used a Type 1 wood glue) will stand up to rain and sun. Cypress or redwood would also make a handsome, weather-resistant planter.

John Olson, Design Editor

Establish a framework

Note: Cedar, cypress, or redwood may have above-average moisture content when you buy it. As the lumber dries, it shrinks, so to avoid joints that open up, stack the lumber with $\frac{1}{4}$ "- or $\frac{1}{2}$ "-thick stickers between layers so air can reach all sides of it, and allow it to sit for at least a week before beginning construction.

1 From 5/4 (1"-thick) material, rip and crosscut to size the bottom and top long rails (A, C), along with the bottom and top short rails (B, D) [Drawing 1; Cutting Diagram, page 49]. Save a couple of 2 $\frac{1}{4}$ "-wide and 3"-wide cutoffs for setting up the tablesaw in the next step.

2 In your tablesaw, set up a $\frac{3}{4}$ " dado blade and raise it $1\frac{1}{2}$ " above the table. Position the rip fence $3\frac{3}{4}$ " from the blade and cut a test half-lap joint in a pair of 3"-wide cutoffs [Photos A and B]. If the joint fits together snug with the

top and bottom edges flush, cut half-laps in the ripped edges of the bottom long rails (A) and the unripped edges of the bottom short rails (B).

3 Lower the dado blade to $1\frac{1}{8}$ ", test-cut a joint in the 2 $\frac{1}{4}$ "-wide cutoffs, then cut the half-laps in the ripped edges of the top long rails (C) and the unripped edges of the top short rails (D).

4 Rout $\frac{1}{2}$ " round-overs along one face of each end of the rails (A, B, C, D) [Shop Tip, right].

Quick Tip! Save the router setup; you'll use it several more times on the project.

5 Glue together the bottom rails (A, B) and top rails (C, D) to make two rail assemblies [Photo C]. Make sure the ripped edges face the same way, and that the rounded-over ends on opposing rails face each other.

6 Taking small cuts to sneak up on a snug fit, cut the floor braces (E) to

MAKE THE FIRST OF TWO PASSES



Attach an extension to your miter gauge to back up the cut and steady the workpiece. Butt the end of the cutoff against the rip fence and cut a dado.

ADD A SPACER TO THE FENCE

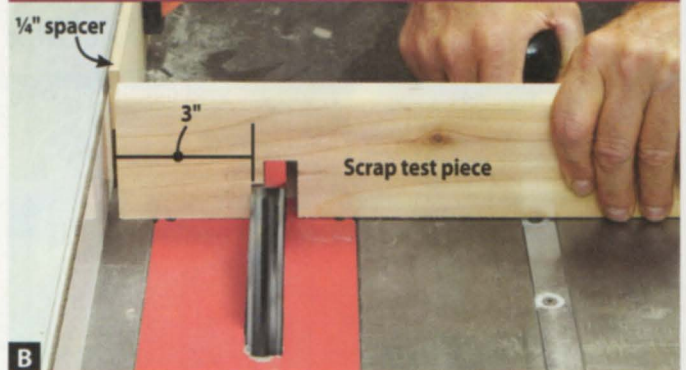

Attach a 1/4"-thick spacer to the rip fence, butt the test piece against it, and make another pass to widen the dado to 1".

MAKE A DRY RUN FIRST

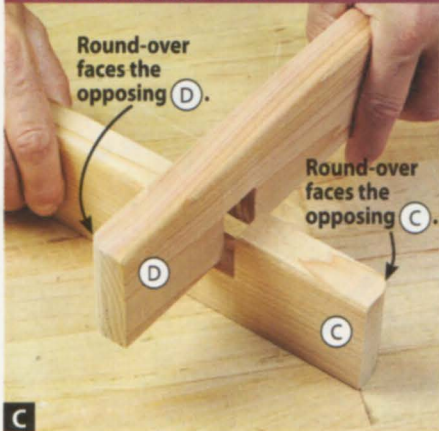

Dry-fit the top rails (C, D) and bottom rails (A, B) so you orient all the pieces correctly. Then remove one short rail at a time and glue the rails together.

SHOP TIP

Group the rails for round-overs

Eliminate chip-out by clamping four rails and a scrap together edge to edge with their ends flush, then routing the round-overs. Repeat for each end.

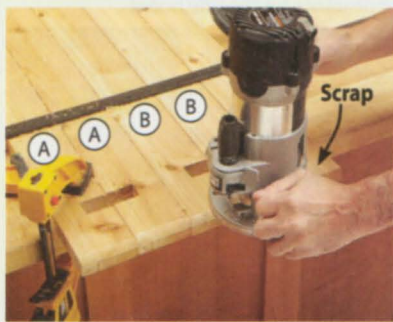

length to fit between the bottom short rails (B) [Drawing 1]; then rip them to width, and screw them in place. **Note:** For all of the screws in this project, drill 3/32" pilot holes to prevent splitting.

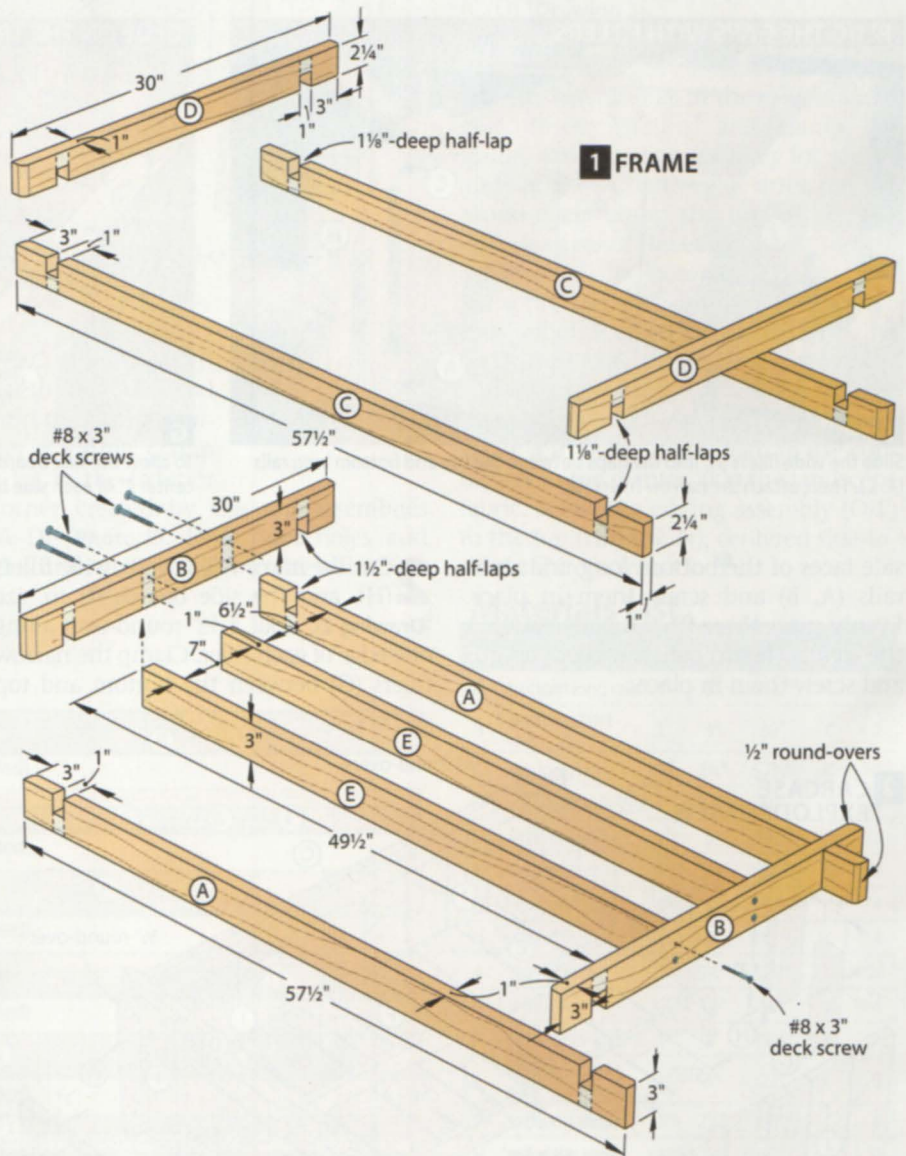

Fill out the framework

1 Measure between the outside faces of the bottom long rails (A) and cut nine floor boards (F) to this length. On two of the floor boards, cut 1x1" notches

on two corners [Drawing 2]. Center an unnotched floor board on the length of the bottom long rails and screw it in place [Shop Tip on page 48]. Position the notched floor boards flush with the out-

ATTACH THE SIDE BOARDS



D Screw a side board (I) flush to the rails (A, C) at each end and one centered between the ends. Space the remaining side boards evenly in the gaps.

THE CORNERS CRADLE THE LEGS



E After drilling and countersinking the pilot holes, apply glue to the faces of the rails (A–D) and screw the legs (J) in place.

PLUG THE GAPS WITH FILLERS



F Slide the wide fillers (H) into the gaps between the top and bottom long rails (A, C). Then, attach the narrow fillers (G).

GLUE ON THE TRIM



G To allow the side boards (I) to expand and contract, apply glue to only the center 2" of each side board; then clamp the trim (K, L, M, N) in place.

side faces of the bottom long and short rails (A, B) and screw them in place. Evenly space three floor boards between the center board and notched boards and screw them in place.

2 Cut the narrow fillers (G), wide fillers (H), and the side boards (I) to size [Drawing 2]. Rout a $\frac{1}{2}$ " round-over along one edge of each filler. Clamp the narrow fillers (G) between the bottom and top

SHOP TIP

How to set up your cup

Orient the floor boards (F), and later the side boards (I), so any cup faces the floor braces (E) or the rails (A–D). This prevents water from pooling on the top face of the floor boards and provides a flatter, less-scalloped appearance for the side boards.

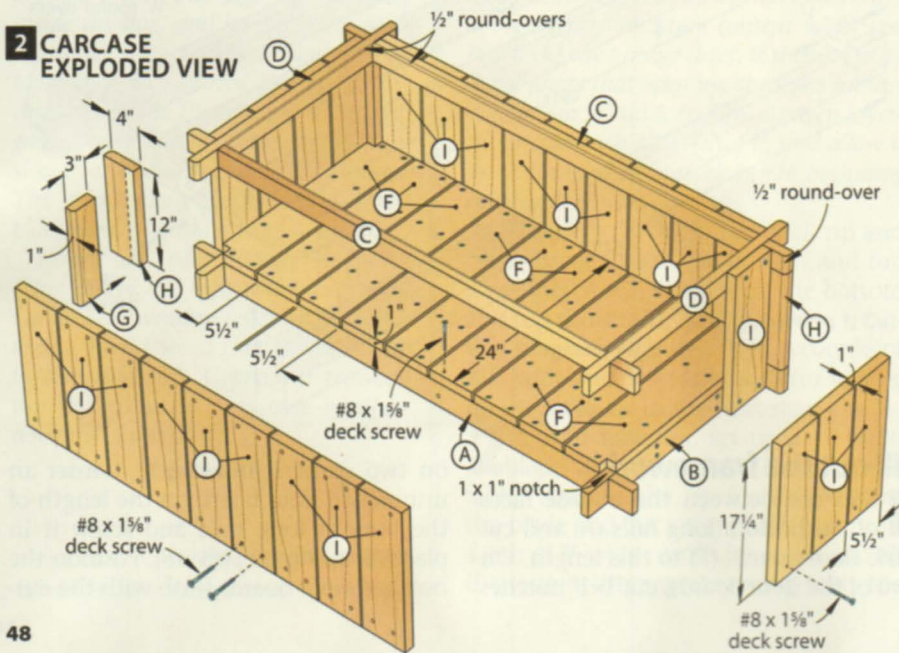
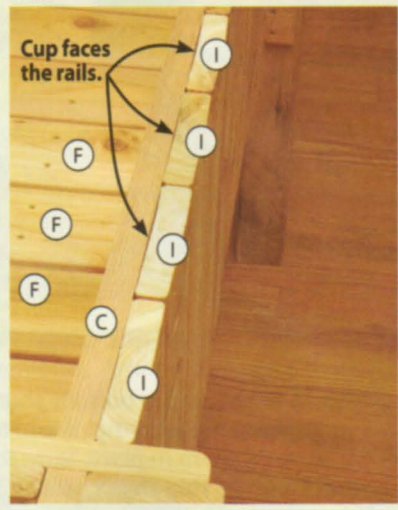

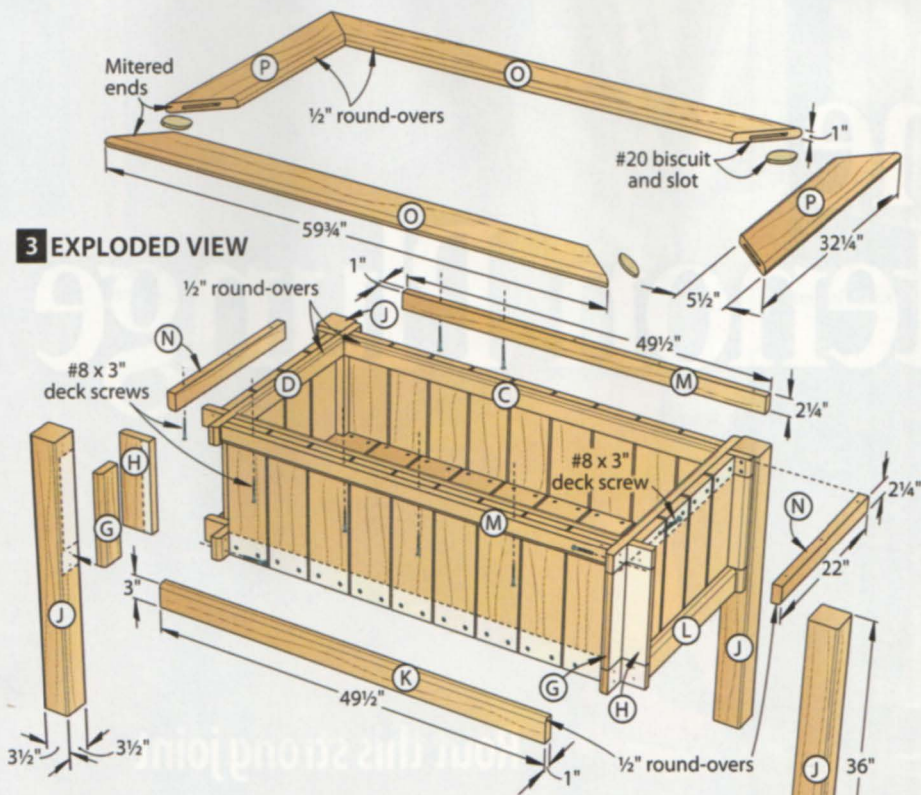

3 EXPLODED VIEW

short rails (B, D) to serve as spacers [Photo D]. **Note:** The ripped edges of the rails should face up. With this assembly on its side, check that the top and bottom rail assemblies (A/B, C/D) align; then begin screwing the side boards to the long rails (A, C). Attach the remaining side boards to the other three sides. Remove the fillers.

3 Cut the legs (J) to length and working on one corner at a time, clamp a leg to the exterior corner created by the rail assemblies (A–D) [Photo E]. Drill pilot holes and glue and screw the legs to the rails.

Quick Tip! Drill the pilot holes within $\frac{5}{8}$ " of the face of the side boards (I). The trim (K, L, M, N) applied in the next step then hides the screwheads.

4 Glue and clamp the narrow fillers (G) and wide fillers (H) to the legs (J) [Photo F, Drawing 3]. Cut the top and bottom long and short trim (K, L, M, N) to size. Rout a $\frac{1}{2}$ " round-over along one edge of each trim piece. Glue and clamp the trim to the side boards (I) flush with their ends and with the round-overs facing each other [Photo G]. After the glue dries, rout $\frac{1}{2}$ " round-overs on the top inside edges of the top rail assembly (C/D) [Drawing 3].

5 Miter-cut the long edging (O) and short edging (P) to size [Drawing 3]. Cut #20 biscuit slots in the miters, apply glue, insert biscuits, and clamp the frame, checking the assembly for square and flatness. After the glue dries, rout $\frac{1}{2}$ " round-overs along the top inside and outside edges of the edging.

6 Sand all surfaces to 150 grit and apply a weather-resistant finish. (We brushed on three coats of a penetrating oil finish.) After the finish cures fully, if you intend to fill the box with soil, line the planter with landscape fabric and staple it in place. If you plan to use containers in the planter, skip the landscape fabric. Screw the edging assembly (O/P) to the top trim (M, N), centered side-to-side and front-to-back. 🌱

Cutting Diagram

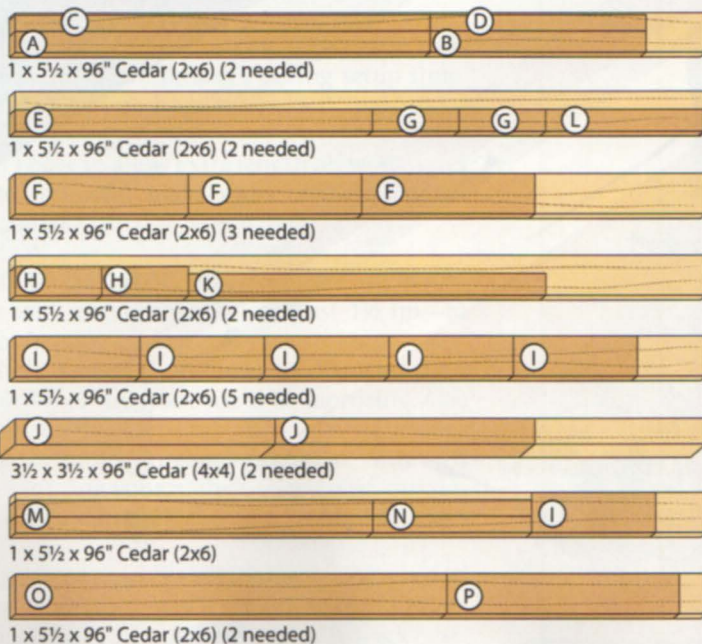

Materials List

Part	FINISHED SIZE			Matl.	Qty.	
	T	W	L			
A	bottom long rails	1"	3"	57 1/2"	C	2
B	bottom short rails	1"	3"	30"	C	2
C	top long rails	1"	2 1/4"	57 1/2"	C	2
D	top short rails	1"	2 1/4"	30"	C	2
E	floor braces	1"	3"	49 1/2"	C	2
F	floor boards	1"	5 1/2"	24"	C	9
G	narrow fillers	1"	3"	12"	C	4
H	wide fillers	1"	4"	12"	C	4
I	side boards	1"	5 1/2"	17 1/4"	C	26
J	legs	3 1/2"	3 1/2"	36"	C	4
K	bottom long trim	1"	3"	49 1/2"	C	2
L	bottom short trim	1"	3"	22"	C	2
M	top long trim	1"	2 1/4"	49 1/2"	C	2
N	top short trim	1"	2 1/4"	22"	C	2
O	long edging	1"	5 1/2"	59 3/4"	C	2
P	short edging	1"	5 1/2"	32 1/4"	C	2

Materials key: C—cedar.

Supplies: #8x1 1/2" exterior deck screws (176), #8x3" exterior deck screws (56), #20 biscuits (4).

Blade and bits: Dado blade; 1/2" round-over bit; 3/32" drill bit.

Produced by
Craig Ruegsegger
with
Brian Bergstrom
Project design:
John Olson
Illustrations:
Lorna Johnson

Take the Loose-tenon Plunge

Rout this strong joint quickly and accurately with a plunge router and a simple jig you can build.

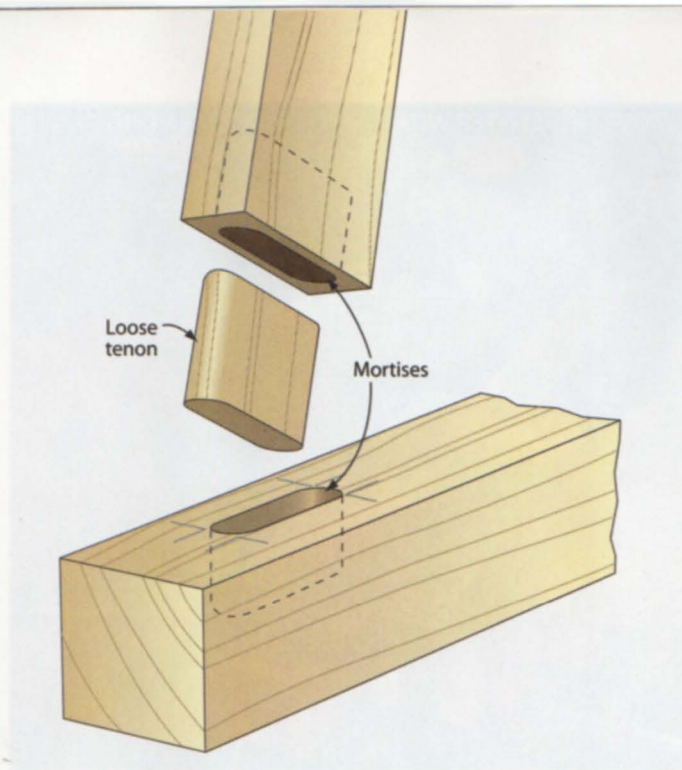

LOOSE-TENON JOINT

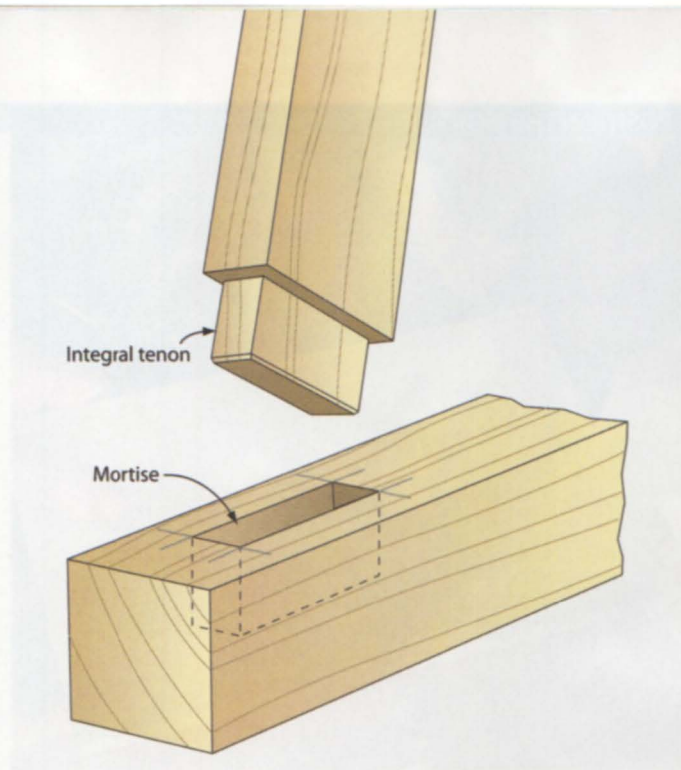

TRADITIONAL MORTISE-AND-TENON JOINT

Also known as *floating tenons*, this joinery method features a piece of wood—the tenon—inserted into matching mortises, as shown *above*, and it's just as strong as a joint made with integral tenons, shown *above right*. Loose-tenon joinery trumps traditional mortise-and-tenon construction in the following ways:

- ▶ With a plunge router, you can rout mortises in long, wide, or thick workpieces too unwieldy to place on a mortiser or drill-press table. (That's why we used loose-tenon joinery for the Traditional Bed on *page 34*.)
- ▶ By using one bit, you create consistently sized mortises with clean, smooth walls for the best gluing surface. And you eliminate the fuss of custom-fitting each tenon to a bored-out or chiseled mortise.
- ▶ You can make surplus loose-tenon stock in common sizes and keep it on hand for future projects, saving setup time. And you can make this stock from scrapwood that might otherwise be tossed out.
- ▶ Because you don't have to allow extra length on workpieces for the integral tenons, you make more efficient use of furniture-grade material.

What you need to get started

- ▶ A plunge router with enough power—at least 1½ hp—to rout mortises in hardwoods.
- ▶ An upcut spiral bit, typically no larger in diameter than one-third the thickness of the stock you'll be mortising. (See **Make wise bit choices** at *right*.)
- ▶ A jig for guiding the router on your workpieces. Although you can rout mortises using your router's edge guide, our jigs work better because they trap the bit, keeping it from accidentally wandering.
- ▶ A guide bushing, larger than the bit diameter and sized to fit the slot on your jig. Because you'll seldom make mortises larger than ½" wide, ⅝" and ¾" bushings typically work best.

Make wise bit choices

We recommend upcut spiral bits for mortising because they plunge easily into wood, cut without grain tear-out when sharp, and the upward-angled flutes pull chips out of the mortise for cooler cutting. A downcut spiral bit pushes the chips deeper into the mortise, creating more heat and potentially dulling the bit quicker.

A straight bit can also be a good choice *if* you get one made for plunge cutting. This design has shear-cutting bevels at its tip (*bottom left*). Straight bits without this feature (*bottom right*) trap tiny "islands" of wood between the carbide tips, preventing the bit from plunging straight down.

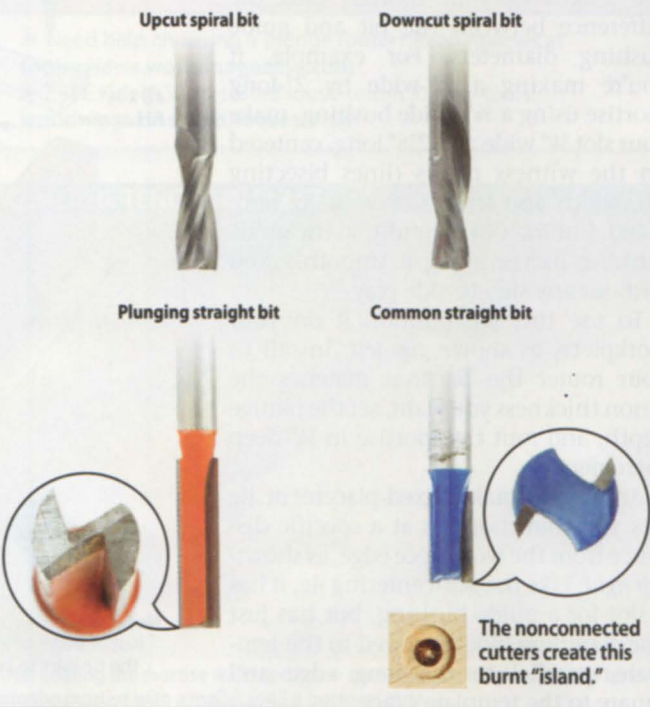

POSITION THE MORTISING JIG

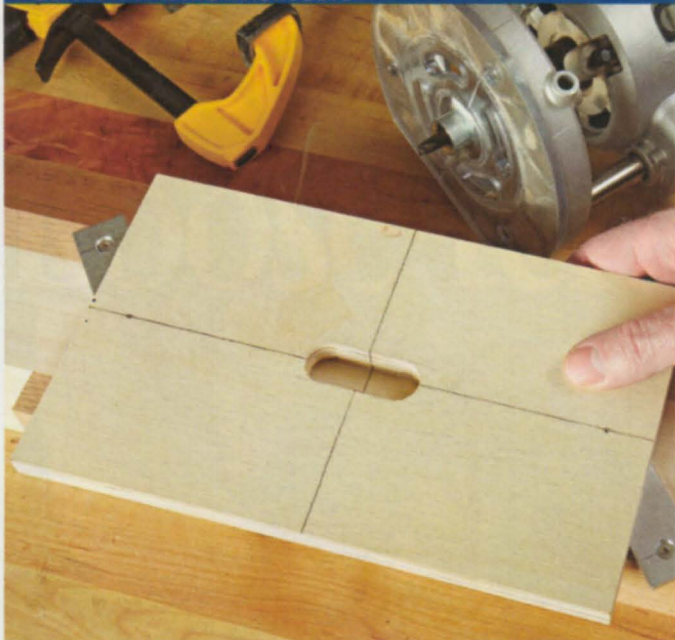

Mark the center of the mortise on your workpiece, then align the jig's witness marks to that centerline. Pivot the clamping blocks to capture the workpiece.

MOVE OFF-CENTER WITH A FIXED-PLACEMENT JIG

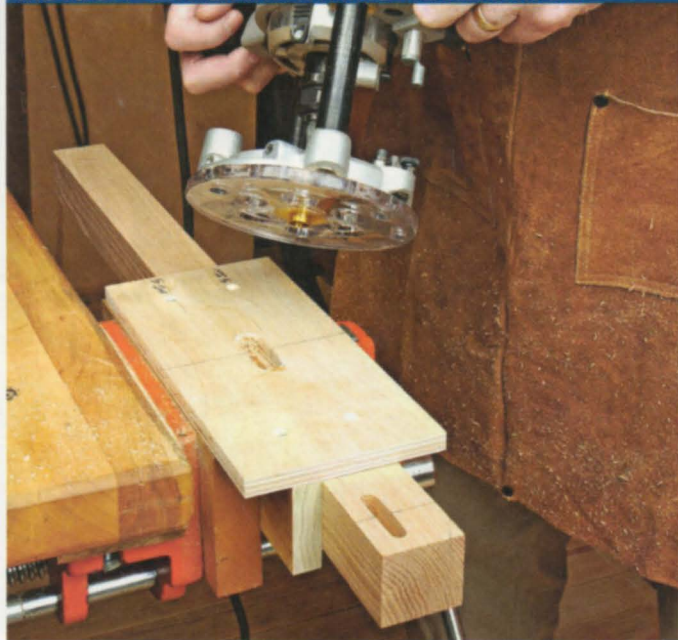

As shown in this setup, you can rout mortises offset from the center of the workpiece. To change the offset, simply reposition the clamping block.

Make a mortising jig

Two types of shop-made jigs work great for plunge-mortising: self-centering and fixed-placement. First, let's take a look at a self-centering jig that, as its name suggests, automatically centers mortises across the thickness (or width) of your workpiece. The one shown at *right* centers mortises on stock up to $3\frac{1}{4}$ ".

When building the jig, cut the slot to the length of your mortise plus the difference between the bit and guide bushing diameters. For example, if you're making a $\frac{1}{2}$ "-wide by 2"-long mortise using a $\frac{5}{8}$ " guide bushing, make your slot $\frac{5}{8}$ " wide and $2\frac{1}{8}$ " long, centered on the witness marks (lines bisecting the width and length of your jig template). Cut the slot carefully so the guide bushing moves along it smoothly and without any side-to-side play.

To use this jig, position it on your workpiece, as shown *top left*. Install in your router the bit that matches the tenon thickness you want, set the plunge depth, and rout the mortise in $\frac{1}{4}$ "-deep increments.

An easy-to-make, fixed-placement jig lets you rout mortises at a specific distance from the workpiece edge, as shown *top right*. Like the self-centering jig, it has a slot for a guide bushing, but has just one clamping block screwed to the template, parallel to the long edge and square to the template's face.

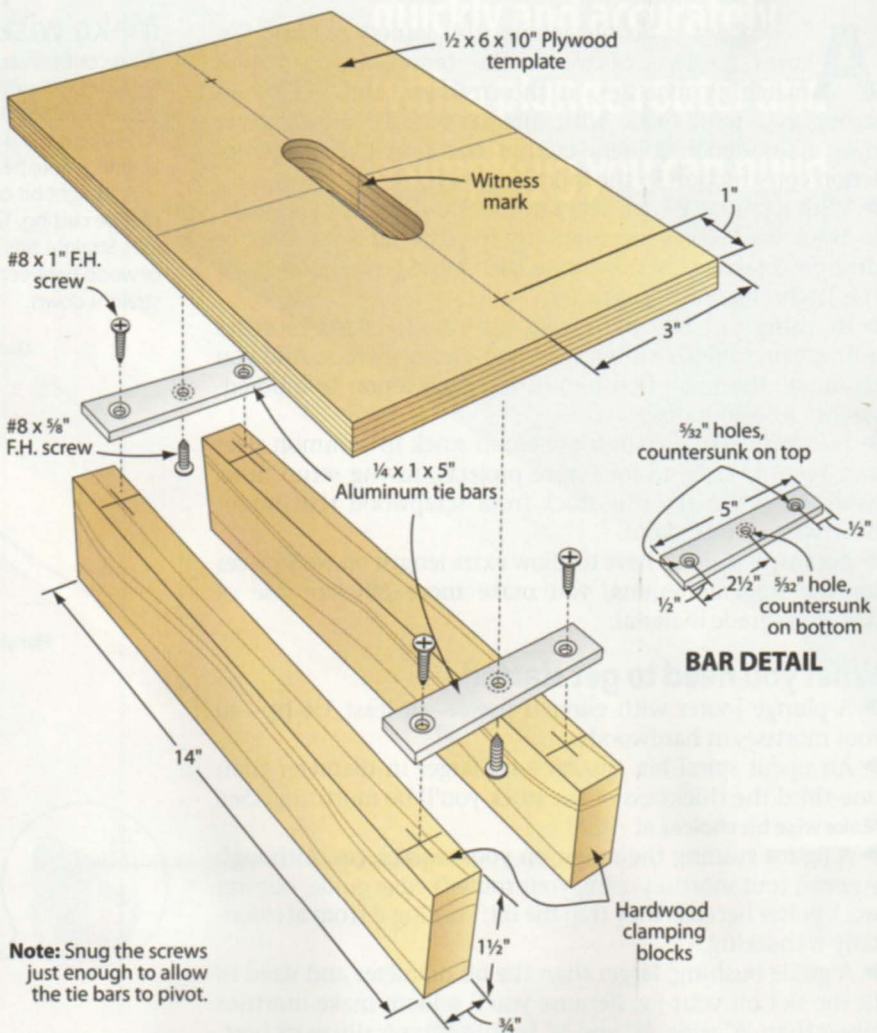

MAKE A POINT OF ROUNDING THE TENON EDGES



Using a round-over bit slightly larger than half your stock's thickness— $\frac{1}{4}$ " for this $\frac{3}{8}$ "-thick blank—round the edges, creating arch-shaped edges.

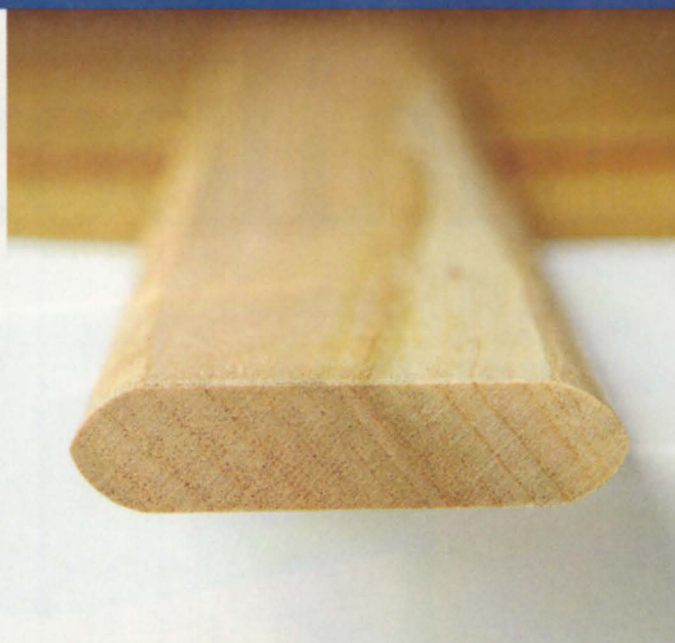

The "pointed" edges of the tenons register against the rounded ends of the mortises while creating space for excess glue to collect.

Now make the loose tenons

Use only hardwoods for tenon stock because softwoods lack the strength needed. For best results, choose straight-grain boards with no knots or defects. **Quick Tip:** Use sapwood cutoffs from cherry and walnut to make loose tenons. Although colored differently, this wood has the same strength and traits of the heartwood.

Begin by planing tenon stock to a thickness equal to the width of your mortise. The fit should be snug enough to keep the tenon in a mortise when tipped upside down, but still allow you to pull it out easily by hand. If you don't have a planer, rip tenon stock to thickness on your tablesaw.

Now, rip the tenon blanks to width, equal to the full length of the mortise. Next, round the edges on a router table, as shown *above*. Finally, crosscut the individual tenons to length, and ease the crisp ends of the tenons, as shown *below*.

Tips for loose-tenon assembly

Because this method requires applying glue to twice as many mortises as integrated-tenon joinery, it's best to cut the job in half. Start by gluing tenons into mortises on project parts that form one-half of joints, as shown *below*. There's no need to clamp snug-fitting tenons on this half. With that done, glue and clamp the remainder of the joints. 🌲

Produced by **Bob Hunter** with **John Olson** and **Kevin Boyle**

More Resources

- ▶ Need help choosing a plunge router? Read reviews at toolreviews.woodmagazine.com
- ▶ FREE Video: Shop-tested loose-tenon joinery tools: woodmagazine.com/loosetenon

EASE THE ENDS



Plane or sand a slight chamfer on the tenon ends so they slip easily into the mortises and scrape less glue from the mortise walls.

GLUE THE TENONS IN PLACE



After coating the mortise walls and lower tenon faces with glue, tap the tenon into the mortise with a mallet until it bottoms out.

Timber-frame Mailbox Post

Here's a way to try your hand at timber framing without having to build something as large as a barn or pergola. You'll cut and chop mortises and tenons in the time-honored way, though with some help from power tools to ease the work. And building it won't cost much because all you need is pressure-treated lumber from the home center. So grab a mallet and some sharp chisels, and set to work!

Nate

Nate Granzow, General-Interest Editor

Mill the four parts

Note: Treated lumber usually has high moisture content, preventing finish absorption and promising dramatic wood shrinkage. So stack your lumber, allowing air to circulate on all sides, and let it sit for at least a week before you begin work. Also, wear a respirator and ensure your shop is well ventilated when cutting or milling pressure-treated lumber to avoid inhaling the dust.

1 Cut the post (A) to length from 6×6 stock [Materials List, page 57]; then, cut the box arm (B) and back arm (C) to length from 4×6 material. Lay out the angles of the brace (D) and the brace tenons on a 2×8 board [Drawing 1, Photo A].

Note: Use a 1/4×1×45" fairing stick to mark the curved edge. Cut the brace to size.

IT'S HIP TO USE A SQUARE



Lay out angles using a marker and rafter square; then, clamp the square in place as a guide for your circular saw when cutting the angled ends.



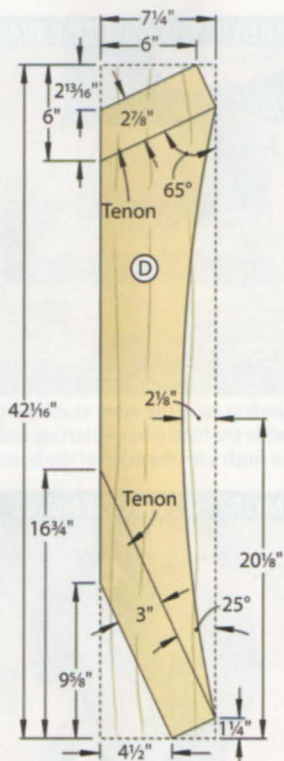

1 PARTS VIEW

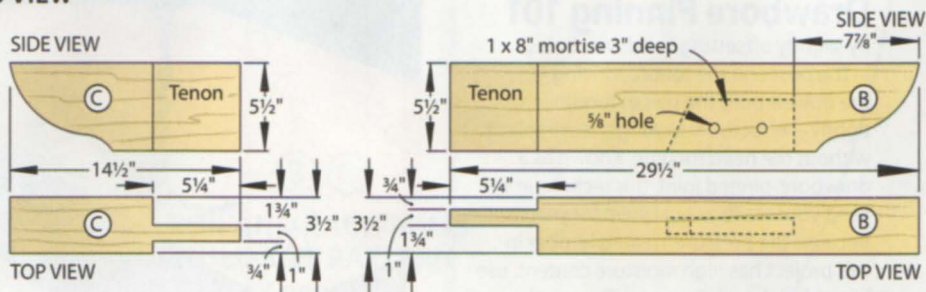

2 EXPLODED VIEW

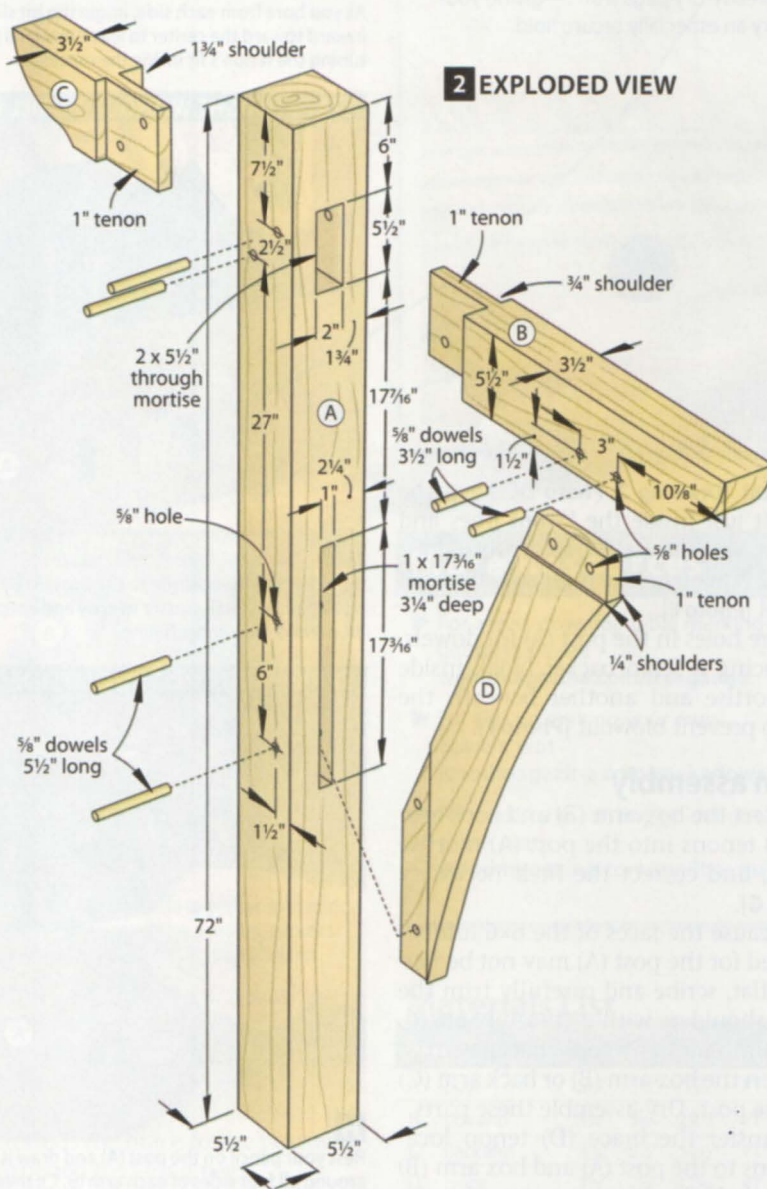

SCRATCH OUT THE TENON

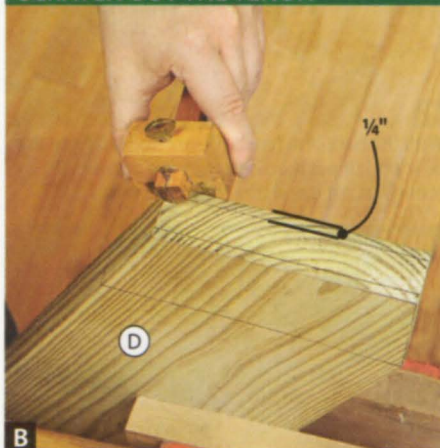

Use a marking gauge to quickly and accurately lay out the tenons, and later, the mortises. You can run a pencil in the scribe mark to make it more visible.

BLADE KERFS KEEP CHISEL ON TRACK



Pare across the grain to prevent your chisel blade from following the grain and cutting too deeply. Use the blade kerfs as a depth reference.

2 Lay out the tenons on the box arm (B) and back arm (C) [Drawing 1].

Note: The box- and back-arm tenons are offset to fit alongside each other inside the post (A) mortise. Mark 1/4" shoulders on the brace (D) tenons [Drawing 2, Photo B].

3 Checking your setup on scrap, set your circular-saw blade to cut 1/4"

deep. Cut repeated kerfs across the marked tenons on the brace (D), and then pare away the waste with a wide chisel [Photo C]. Reset the blade depth to cut the tenons on the box arm (B) and back arm (C).

4 Lay out and bore the upper mortise in the post (A) using a drill and an

Drawbore Pinning 101

By slightly offsetting the dowel holes in the post and the tenons, driving the dowels pulls the pieces together tightly—effectively locking them in place without the need for glue. Known as a drawbore-pinned joint, this technique will keep your mailbox post solid for years. Because the pressure-treated lumber in this project has high moisture content, use kiln-dried dowels for pegs. Though the pressure-treated lumber dries and shrinks, the already-dry pegs won't—giving your joinery an especially secure hold.



auger bit [Drawing 2, Photo D]. Keep the drill bit just inside the layout lines and run the drill at a slow speed for added control. Square up the mortise walls with a chisel [Photo E].

5 Bore holes in the post (A) for dowels, placing a scrap backer block inside the mortise and another beneath the post to prevent blowout [Photo F].

Begin assembly

1 Insert the box-arm (B) and back-arm (C) tenons into the post (A) mortise to test, and correct the fit if necessary [Photo G].

2 Because the faces of the 6x6 lumber used for the post (A) may not be perfectly flat, scribe and carefully trim the tenon shoulders with a chisel [Photo H]. This eliminates any gaps that may exist between the box arm (B) or back arm (C) and the post. Dry-assemble these parts.

3 Transfer the brace (D) tenon locations to the post (A) and box arm (B) [Photo I]. Using a square, transfer the lines to the center of the post and box arm to locate the brace mortises. Bore out the mortises, squaring and cleaning up the mortise walls with a chisel. Dry-assemble all parts to check for fit. Bore peg holes in the post and box arm [Drawing 2], again using backers to prevent tear-out.

BORE HALFWAY FROM BOTH SIDES



D As you bore from each side, angle the bit slightly inward toward the center to leave material for fine tuning the tenon's fit inside the mortise.

STAY STRAIGHT WITHOUT A DRILL PRESS



F Bore holes perpendicular to the post (A) by positioning a small square nearby and keeping the bit parallel to it while drilling.

SCRIBE AROUND THE OUTSIDE

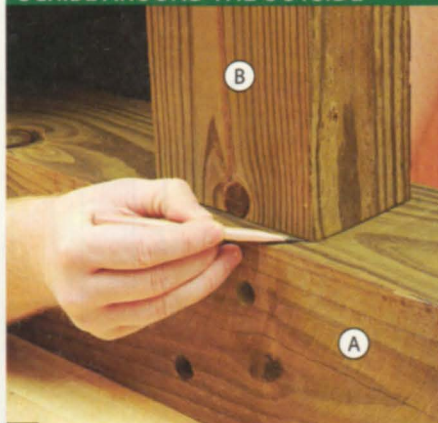

H Rest your pencil on the post (A) and draw it evenly around all four sides of each arm (B, C); then, pare to the line with a chisel to achieve a tight fit.

4 Transfer the peg-hole locations to the box-arm (B) and back-arm (C) tenons [Photo J]. Then, relocate the marked hole centers on the box-arm and back-arm tenons $\frac{1}{8}$ " toward the tenon shoulders. (See **Drawbore Pinning 101**, top left.) Bore

SQUARE UP THE MORTISE WALLS

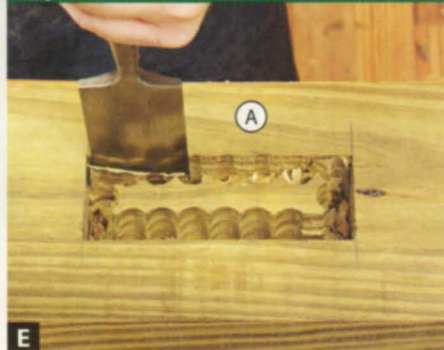

E After chiseling away the more-stubborn cross grain, tackle the long grain—starting each cut with the blade flush with the edge of the bored holes.

ONE MORTISE, TWO TENONS



G With the back-arm tenon (C) inserted fully into the post's (A) upper mortise, scribe the box-arm (B) tenon against it and trim for a precise fit.

KEEP THE BRACE TIGHT



I Place the brace (D) tenons squarely and tightly against the post (A) and box arm (B); then, mark their locations.

the holes in the tenons. Repeat this process for the brace (D) tenons.

5 Following the pattern on the *next page*, bandsaw the ends of the box arm (B) and back arm (C) to shape and sand smooth.

(B), (C)

BOX AND BACK ARMS FULL-SIZE PATTERN (2 needed)



TAP THE BIT TO MARK THE HOLES

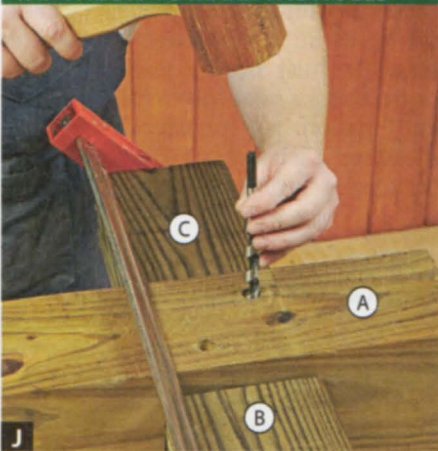

Draw the joints tight with a clamp; then place the auger bit into the holes in the post (A) and tap it with a mallet to mark the peg-hole locations.

Final assembly

1 Insert the brace (D) tenon into the box-arm (B) mortise. Sharpen one end of two 4½"-long pegs (as shown

DROP IN THE BRACE ASSEMBLY



A well-fitted joint should slide together with hand pressure only—if you must use a mallet, protect the project by striking against a piece of scrap.

above right) and drive them into the peg holes with a mallet. Cut them off with a handsaw; then sand them flush. Insert the brace assembly (B/D) into the post (A) mortises [Photo K] and likewise pin the bottom of the brace to the post with two sharpened 6½"-long pegs.

2 Insert the back arm (C) into the post (A) mortise and drive the last two 6½"-long pegs through the post, back arm, and box arm (B).

3 Apply several coats of water-repellent preservative to the mailbox post. Getting the finish applied to your project soon after completion, especially on end grain, helps to prevent checking. 🌱

More Resources

- ▶ For a free, downloadable marking-gauge plan, see woodmagazine.com/freegauge.
- ▶ For tips on making your own dowels, visit woodmagazine.com/makedowels.
- ▶ For mailbox mounting guidelines, check out woodmagazine.com/mailboxguide.

Materials List

Part	FINISHED SIZE				Matl.	Qty.
	T	W	L			
A post	5½"	5½"	72"		PT	1
B box arm	3½"	5½"	29½"		PT	1
C back arm	3½"	5½"	14½"		PT	1
D brace	1½"	7¼"	42¼"		PT	1

Materials key: PT—Pressure-treated pine.

Bit: ⅝" auger drill bit.

Supplies: ⅝x36" oak dowel.

Produced by Nate Granzow with John Olson

Project design: John Olson

Illustrations: Lorna Johnson

SHOP TESTED

Ductwork-Worthy Dust Collectors

As your collection of woodworking machines grows, so does the amount of sawdust you create, and with it, the nuisance of rolling a portable dust collector from machine to machine. On the other hand, a dust collector that services your entire shop through a system of fixed ductwork saves you that hassle, keeps your shop cleaner, and, with good filtration, reduces the amount of airborne dust that can damage your health. To collect debris through a duct network without clogging, a collector needs to generate at least 800 cubic feet per minute (CFM) of airflow. But what type of collector—see the sidebar on the *next page*—and which models do the job best? To find out, we tested a variety of machines capable of handling a full-shop duct system. Here's what you need to know.

Job one: gather the dust

These machines work best when hooked to a 6"-8" duct network. So we tested each collector's suction ability by measuring its airflow through 6"-diameter duct, the inlet size for four of the test units. Using a pitot tube (velocity meter) and manometer (pressure gauge), we measured each unit's airflow (CFM) at various levels of resistance, measured in

Experts deliver tech knowledge with an eye for woodworking

To deliver the most fair and accurate testing results, we hired Tom Brumback and Doug Ley, two woodworkers who earn their living as engineers with a major agricultural seed testing company. They helped us procure the right testing equipment and knew how to use it to analyze the performance of the collectors under real-shop conditions.



Tom Brumback



Doug Ley

We tested nine 220-volt units priced from \$675 to nearly \$1,600, looking for the machine(s) best capable of sucking up dust through a ducted central-collection system—and then trapping it.

Learn to tell dust collectors apart

A single-stage dust collector sucks dust and chips directly into its impeller, the fan that generates airflow. The impeller then blows that debris into the "containment" portion of the machine. Heavier chips settle into the bottom bag or bags, while fine dust gets forced up into the top filter, a fabric bag or pleated canister. As the air passes through the filter, most dust becomes trapped inside. Single-stage collectors have either two bags/canisters (110 volts) or four bags/canisters (220 volts), sell for less than most

two-stage cyclones, and work great if adequately equipped with efficient filters and hose/duct setups. But because everything passes through the impeller, large pieces, such as knots, small cutoffs, nails, or screws, can damage the fan, bags, or hose.

A two-stage dust collector, also known as a cyclone, routes dust-laden air through a cone-shaped cylinder that slows the air velocity and separates the heavier debris into a collection drum before it can get to the fan. The fine dust

that remains airborne passes harmlessly through the impeller and into the filter, typically a pleated canister. Cyclones usually require 220 volts and either a wall-mount bracket or floor stand, but some smaller, portable units run on 110 volts and work best with short lengths (20' or less) of duct or flex-hose.

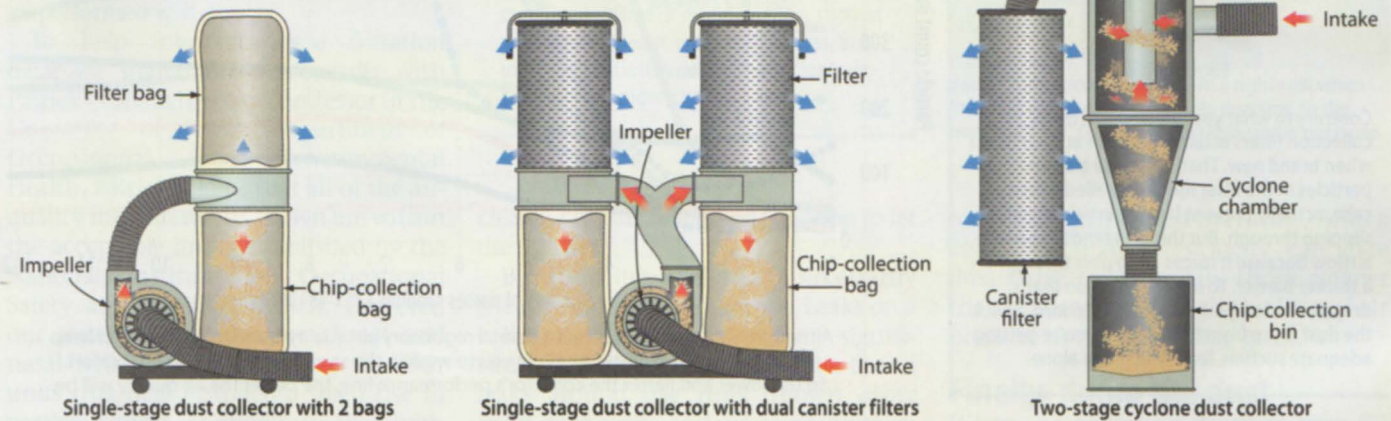

Collecting the dust proves the first half of the battle

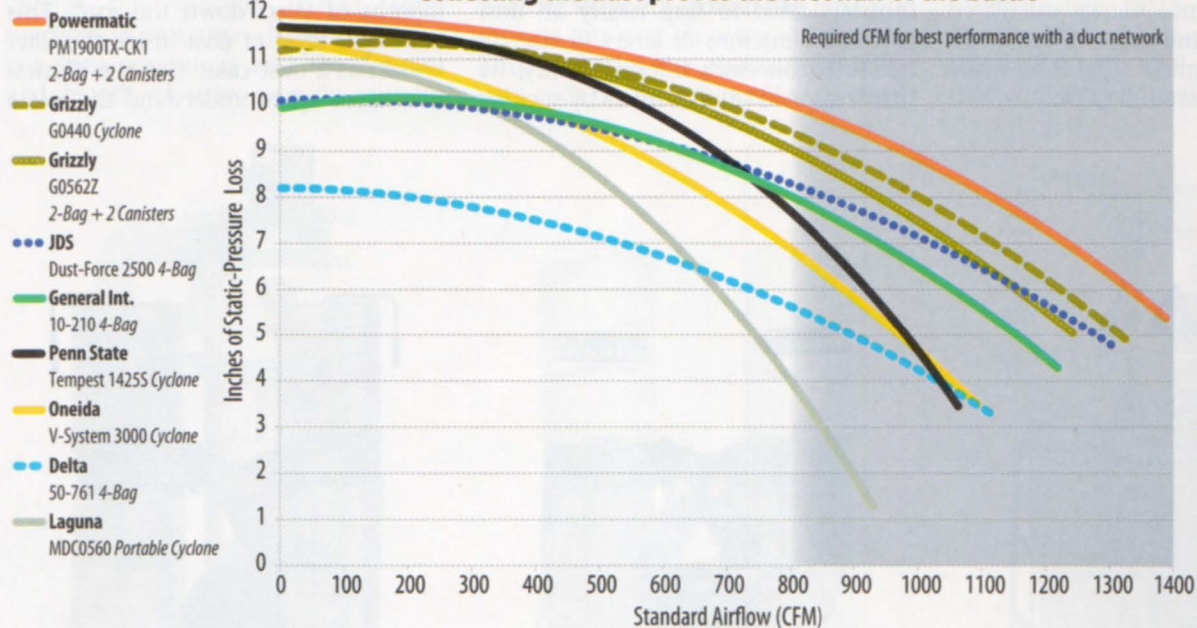

To see which collectors provide enough airflow for your system, calculate the total static-pressure loss of your ductwork, find that figure on the left-hand column, and then draw a line across the chart at that level. Any collector with a performance arc above that line in the shaded area would be suitable.

inches of static-pressure (SP) loss. This method simulates the resistance that results from adding elbows, increasing duct length, and changing duct diameter to any shop duct network. From these figures, we generated fan curves, above, to demonstrate each collector's performance in increasingly challenging shop settings.

All but one unit we tested easily achieved the required 800 CFM while overcoming at least 5½" of SP loss. That's what it takes to power a typical shop ceiling-mounted ductwork setup with a 25' main 6" trunk with three 90° elbows, four 45° elbows, and five 4" duct and flex-hose drops to machines. Laguna's MDC0560-0145 portable cyclone, which

overcame just 4" of SP loss at 800 CFM, would perform favorably if placed in a more central location with duct runs no longer than 15' and no more than four machine drops.

In order to select a dust collector for your shop, first calculate the amount of static-pressure loss your planned or existing ductwork will create. To do this,

Buildup inside filters helps trap dust better

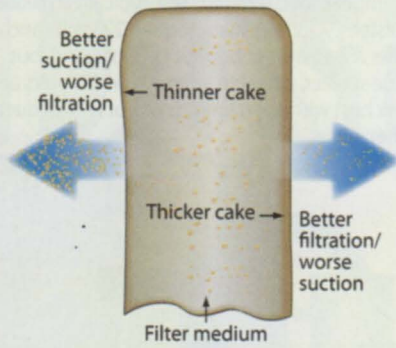

Contrary to what you might think, dust-collection filters actually perform at their worst when brand new. That's because trapped dust particles in the filter medium, called a dust cake, actually prevent larger particles from slipping through. But this also tends to reduce airflow because it forces air to pass through a thicker barrier. To improve suction that's dropped below your "normal" standard, knock the dust loose from the filters; if you're getting adequate suction, leave the filters alone.

Trapping the dust in the filter means you won't breathe it

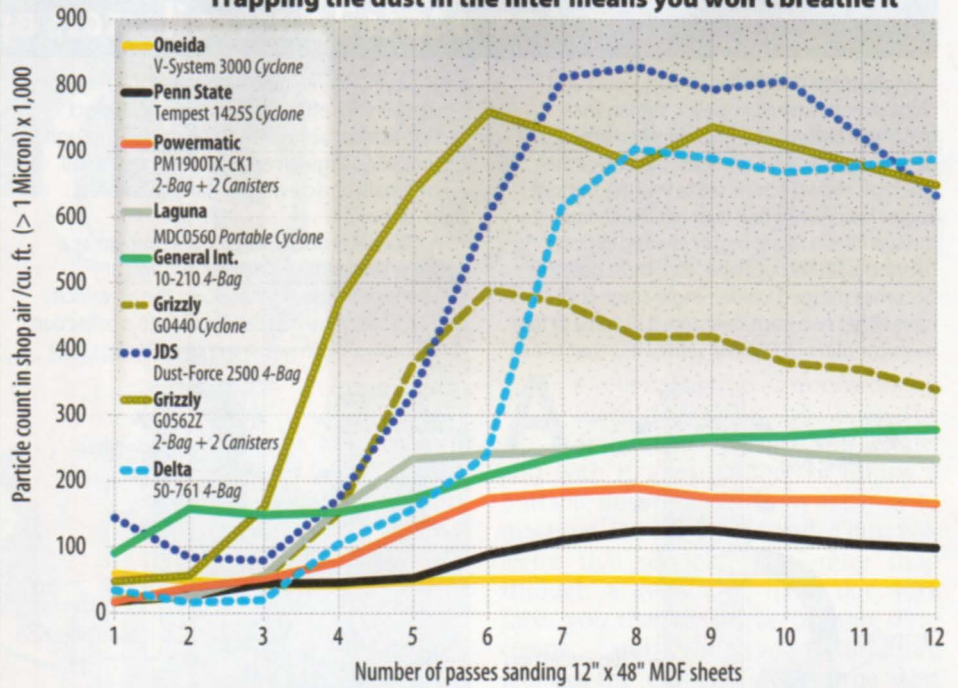

Although all of the filters meet industrial regulatory air-quality standards, those that keep airborne particle counts low allow you to work in the shop longer without discomfort. So the lower and flatter the collector's performance line, the better the air quality will be.

download a free article with step-by-step instructions at woodmagazine.com/wholeshopdc. Once you've calculated the total SP loss, find a collector that will overcome that much resistance while maintaining at least 800 CFM.

Now return clean air to the shop

All the test models have filter bags or canisters rated to trap nearly all dust particles 2 microns or larger in size. To test each collector's filtering ability, we first "seasoned" all the filters by sucking

up MDF dust to fully load the filter media, replicating filter performance months or years down the road. This built up a layer of dust inside the filter known as a dust cake. (See the illustration *above left* to understand the role a



Delta 50-761, \$1,000
800-223-7278, deltamachinery.com

The only single-stage collector with its motor and impeller not positioned on the base, but rather at the height midpoint, the 50-761 demonstrated less airflow than all but one other unit. Because of this design, you'll have to add an additional 90° fitting to hook up ceiling-mounted duct, adding more resistance.



General International 10-210, \$870
888-949-1161, general.ca

The 10-210 sports a good combination of airflow and filtration. It has an adjustable vane inside the plenum (the curvy Y-shaped discharge chute) to let you control the flow of debris into each bag. It comes with two extra plastic collection bags.



Grizzly G0562Z, \$675
800-523-4777, grizzly.com

The G0562Z moves dust nicely, but with the most leaks around welds, connections, and bag rims of any test unit, it also sent much of the fine dust back into the air. Made of the lightest-gauge steel among the group, this machine displays more wobble than others when moving around the shop.

dust cake plays in a filter.) With that accomplished, we sanded MDF sheets—for material consistency—with a drum sander, and used a digital particulate meter to measure the number of dust particles larger than 1 micron floating in the shop air during and after each pass.

As shown in the chart at left, the Oneida V-System 3000 cyclone did the best job at trapping dust particles during use. The Penn State Tempest cyclone, Powermatic, General International 10-210, and Laguna all performed well, too.

To help interpret these filtration data, we shared our test results with Patrick O'Shaughnessy, a professor in the University of Iowa's Department of Occupational and Environmental Health. Patrick told us that all of the air-quality measurements shown are within the acceptable limits established by the National Institute for Occupational Safety and Health (NIOSH). However, our testers observed more throat and nasal irritation when testing the four units that demonstrated a steep rise in particle counts, as shown in the chart. Patrick also cautions that the performance of each collector could likely change—but still be relative from machine to machine—based on different shop conditions and the amount and length of work you do without

So how big is a micron?

The dust-collection industry and health regulatory agencies measure air particles by microns. One micron equals .001 millimeter—far too small to see without magnification. By comparison, human hair typically measures about 40–60 microns in diameter. Dust particles smaller than 30 microns—most of them nearly invisible—can remain airborne for about 30 minutes before settling, so it's important to trap them before they get into the air. And some woodworkers are more sensitive to dust from different wood species, such as western red cedar, walnut, sassafras, and imported varieties, so for them clean air proves even more critical.

clearing the air or leaving the shop to let dust settle.

But the filter media isn't necessarily the main source for dusty air. Leaks on a collector can also contribute significantly to the particle count. We found leaks around bag rims (shown above right), spot welds, and unsealed joints on all but the Laguna and Oneida machines. We patched these leaks by adding foam weather stripping around bag rims, and silicone caulking on other visible leaks. This improved the air-quality reading with each fix, but will need to be moni-

SMALL LEAKS LET FINE DUST ESCAPE



Band clamps don't always form a tight seal when securing a bag, which is usually oversized, to the machine's rim, creating a dust leak under pressure.

tored and maintained over time. And, a collector's high air velocity can force dust particles, especially those smaller than 3 microns, through the filter if air pressure in the filter is too great.

Finally, dump the dust

When the collection drum or bags fill with debris, you should be able to empty them without creating a dust cloud. Unfortunately, that's seldom the case. The Grizzly and Laguna cyclones make this easiest with steel drums on casters that conveniently roll out from under



Grizzly G0440, \$1,375
800-523-4777, grizzly.com

This collector has the largest footprint of all the test machines. Its pulley-operated up-and-down filter cleaner worked well. It was loudest in the test, and so-so on dust containment. A small hose connects to the drum, providing suction to draw the disposable liner against the sidewalls, helping the bag fill better.



JDS Dust-Force 2500, \$970
800-480-7269, jdstools.com

Made with heavy-duty components, the Dust-Force 2500 does a good job of collecting dust. Although we sealed leaks around the bag rims with foam weather stripping, fine dust continued to escape into the shop air. If you prefer more-efficient canister filters, get this machine in that configuration for a \$400 upcharge.



Laguna MDC0560-0145, \$1,349
800-234-1976, lagunatools.com

A compact, portable cyclone with limited suction ability, this machine ran the quietest, filtered dust well, and its drum proved easy to dump when full. (A wire screen sits inside the disposable bag to help it fill to capacity.) Its radio-frequency remote control lets you start the collector without aiming directly at it.

ROLL OUT, TIE IT, TOSS IT



With this Grizzly G0440 and the Laguna, you empty the chips and dust by removing a disposable plastic bag inside the roll-out drum.

their separators, as shown above. Penn State and Oneida have casterless fiber drums that proved more difficult to remove from the separator because of a short length of connecting flex-hose that must be compressed and the limited space in which to lift the lid. Shortening the hose an inch or so improved this.

The single-stage collectors all use disposable plastic bags, and all but the Delta have about twice the storage capacity of the cyclones' drums. (Oneida sells an optional 55-gallon drum; ours was 35.) But removing those bags from the machines often results in dust spilled on the floor and spewed into the air.

DUST COLLECTORS SUITABLE FOR A ONE-MAN SHOP

MANUFACTURER	MODEL	PERFORMANCE RATINGS (1)						COLLECTOR TYPE (2)	RATED MOTOR HORSEPOWER
		PRIMARY		SECONDARY					
		AIRFLOW	FILTRATION	EASE OF CLEANING FILTER	EASE OF EMPTYING COLLECTION DRUM/BAGS	EASE OF ASSEMBLY AND INITIAL HOOKUP	CLARITY OF OWNER'S MANUAL		
SINGLE-STAGE COLLECTORS									
DELTA	50-761	B-	C	B-	C+	A-	B	B	2
GENERAL INTERNATIONAL	10-210	B+	A-	B-	C	B	C	B	3
GRIZZLY	G0562Z	A-	C	A	C	B-	C	F	3
JDS	DUST-FORCE 2500	B+	C	B-	C	B+	C	B	3
POWERMATIC	PM1900TX-CK1	A	A-	A	C+	B+	B	F	3
TWO-STAGE CYCLONE COLLECTORS									
GRIZZLY	G0440	A-	B	A	A	C	B-	C	2
LAGUNA	MDC0560-0145	C	A-	A-	A	B-	C-	P	2
ONEIDA AIR SYSTEMS	V-SYSTEM 3000	B	A	A-	B+	B	A	C	3
PENN STATE	TEMPEST TEMP1425S	B	A	B+	B	C	C	C	2.5



Oneida Air Systems V-System 3000, \$1,595
800-732-4065, oneida-air.com

With the smoothest-running impeller, heaviest-gauge steel, best overall fit and finish, and superior dust filtration, this 3-hp cyclone was the cream of the crop. Another plus: It's second-quietest, below the threshold of potential hearing loss (85 dB). An optional wall-mount kit would improve access to the collection drum.



Penn State Tempest TEMP1425S, \$1,355
800-377-7297, pennstateind.com

At 94" tall, this Tempest managed to just fit under our 8' ceiling. It delivers a great combination of airflow and filtration, but an impeller that rattles and shakes when coasting down and a filter cleanout that's attached with just silicone causes us concerns about the machine's longevity and future maintenance.



Powermatic PM1900TX-CK1, \$1,300
800-274-6848, powermatic.com

With an 8" inlet and the best suction of the group, this machine provides lots of options for setting up a ductwork system. It's well-built with heavy-duty features and nice touches, such as an electronic starter with remote, a base wide enough to support bags full of chips and dust, and handles for easier maneuvering.

- A EXCELLENT
 - B GOOD
 - C FAIR
- (B) 2 filter bags, 2 collection bags
 - (C) Stationary cyclone
 - (F) 2 canister filters, 2 collection bags
 - (P) Portable cyclone

CENTRAL-COLLECTION SYSTEM

IMPELLER		FILTER MEDIUM RATING, MICRONS	COLLECTION DRUM/BAG CAPACITY, GALLONS	DIMENSIONS			ACCESSORIES (4)		CORD LENGTH	NOISE LEVEL, DECIBELS		WARRANTY, YEARS	COUNTRY OF ASSEMBLY (5)	SELLING PRICE (6)
DIAMETER, INCHES	MATERIAL (3)			INLET DIAMETER, INCHES	INCLUDED INLET REDUCER	OVERALL DIMENSIONS, INCHES (W×D×H)	STANDARD	OPTIONAL		MEASURED 10' FROM COLLECTOR	MEASURED 20' FROM COLLECTOR			
12	S	1	30	6	4"×3	57×19×87		A	12'6"	84	81	5	C	\$1,000
12	A	2	83	6	4"×3	60×32½×76		A, C	8'	87	83	2	T	870
12¾	S	1	73	7	4"×3	58×32×71		A	10'	87	84	1	C	675
13¾	S	1	84	8	4"×3	55×21×75		C	10'	86	84	1	T	970
14	S	2	75	8	4"×3	60×30×72	R		6'6"	86	84	5	T	1,300
14½	S	2	35	7	NONE	59×37¾×93¼	F, R, S	A, N	6'	90	88	1	C	\$1,375 [†]
14½	S	1	29	6	4"×2	36×26×74	R, S		10'6"	77	73	1	T	1,349
14	A	0.5	35	6	NONE	50×30×84½	D, F, N	A, R, S, W	10'	79	77	1	U	1,595 [†]
14	A	0.5	26	7	7" to 6"	58×26½×94	D, F	A	6'	84	82	5	C	1,355 [‡]

3. (A) Aluminum
(S) Steel

4. (A) Ductwork, flex-hose, and fittings
(C) 1-micron canister filters
(D) Fiber collection drum
(F) Floor stand
(N) Noise reducer
(R) Remote-control starter
(S) Steel collection drum
(W) Wall-mount kit

5. (C) China
(T) Taiwan
(U) United States

6. Prices current at time of article production and do not include shipping, where applicable.
(*) \$1,150 without optional floor stand (H7499)
(†) \$1,560 without optional floor stand but with 35-gallon fiber drum; or \$1,623 with optional 55-gallon fiber drum and floor stand
(‡) \$1,095 without optional floor stand (TEMSTAND2)

Two types, two good choices

When making a decision on which models to recommend, we put the most emphasis on airflow and filtration. We could not identify a clear advantage for one type of collector versus the other: The two best machines—one single-stage unit and one cyclone—would be welcome additions to any shop. That's why we awarded two models our Top Tool award.

If you have or plan a duct system that demands high airflow to overcome static-pressure loss, then get the single-stage Powermatic PM1900TX-CK1. It delivered the most airflow, ranked near

the top in fine-particle filtration, and has nearly twice the chip-storage capacity of the cyclones.

If you don't require that much airflow but desire greater filtration ability, then go for the Oneida V-System 3000 cyclone. It proved best in our test at trapping dust, and its airflow should support a duct system for most typical home shops. The Oneida made an impression on us with its high-quality components, such as heavy-gauge steel and the smoothest-running impeller in the test, and seems best suited to stand up to years of use. 🌱

More Resources

- ▶ Learn more about how to choose a dust collector for your shop at woodmagazine.com/choosedc.
- ▶ Read editor and user reviews of these dust collectors and others, as well as accessories to improve the performance of your machines, at toolreviews.woodmagazine.com.

WOOD MAGAZINE'S
REVIEW-A-TOOL

Produced by Bob Hunter with Tom Brumback and Doug Ley

HARBOR FREIGHT TOOLS

Quality Tools at Ridiculously Low Prices

LIFETIME WARRANTY
ON ALL HAND TOOLS!

FACTORY DIRECT TO YOU!

How does Harbor Freight Tools sell high quality tools at such ridiculously low prices? We buy direct from the factories who also supply the major brands and sell direct to you. It's just that simple! See for yourself at one of our 400 Stores Nationwide and use this 20% Off Coupon on one of our 7,000 products*, plus pick up a Free 1" x 25 Ft. Tape Measure, a \$5.99 value. We stock Shop Equipment, Hand Tools, Tarps, Compressors, Air & Power Tools, Woodworking Tools, Welders, Tool Boxes, Generators, and much more.

- Over 20 Million Satisfied Customers!
- 1 Year Competitor's Low Price Guarantee
- No Hassle Return Policy!
- 100% Satisfaction Guaranteed!
- Over 400 Stores Nationwide

Nobody Beats Our Quality, Service and Price!

FREE!
WITH MINIMUM PURCHASE OF \$9.99

PITTSBURGH
1" x 25 FT.
TAPE MEASURE
ITEM 47737/69080/69030/69031
REG. PRICE \$5.99

Item 47737 shown

LIMIT 1 - Only available with qualifying minimum purchase (excludes gift value). Coupon good at our stores or website or by phone. Cannot be used with other discount, coupon or prior purchase. Offer good while supplies last. Shipping & Handling charges may apply if not picked up in-store. Original coupon must be presented. Non-transferable. Valid through 7/12/13. Limit one coupon per customer per day.



20% OFF
ANY SINGLE ITEM!

LIMIT 1 - Save 20% on any one item purchased at our stores or website or by phone. *Cannot be used with other discount, coupon, gift cards, Inside Track Club membership, extended service plans or on any of the following: compressors, generators, tool storage or carts, welders, floor jacks, Towable Ride-on Trencher (Item 65162), open box items, in-store event or parking lot sale items. Not valid on prior purchases after 30 days from original purchase date with original receipt. Non-transferable. Original coupon must be presented. Valid through 7/12/13. Limit one coupon per customer per day.

66500173

HAULMASTER **MOVER'S DOLLY**
LOT NO. 93888/60497

SAVE 46%

1000 LB. CAPACITY
\$799
REG. PRICE \$14.99

Item 93888 shown

LIMIT 7 - Good at our stores or website or by phone. Cannot be used with other discount or coupon or prior purchases after 30 days from original purchase with original receipt. Offer good while supplies last. Non-transferable. Original coupon must be presented. Valid through 7/12/13. Limit one coupon per customer per day.

PITTSBURGH **24" CLAMP AND CUT EDGE GUIDE**
LOT NO. 66126

SAVE 46%

\$699
REG. PRICE \$12.99

LIMIT 8 - Good at our stores or website or by phone. Cannot be used with other discount or coupon or prior purchases after 30 days from original purchase with original receipt. Offer good while supplies last. Non-transferable. Original coupon must be presented. Valid through 7/12/13. Limit one coupon per customer per day.

drillmaster **29 PIECE TITANIUM NITRIDE COATED DRILL BIT SET**
LOT NO. 5889

SAVE 60%

\$999
REG. PRICE \$24.99

LIMIT 6 - Good at our stores or website or by phone. Cannot be used with other discount or coupon or prior purchases after 30 days from original purchase with original receipt. Offer good while supplies last. Non-transferable. Original coupon must be presented. Valid through 7/12/13. Limit one coupon per customer per day.

PITTSBURGH **6" DIGITAL CALIPER**
LOT NO. 47257

SAVE 66%

\$999
REG. PRICE \$29.99

Includes two 1.5V button cell batteries.

LIMIT 9 - Good at our stores or website or by phone. Cannot be used with other discount or coupon or prior purchases after 30 days from original purchase with original receipt. Offer good while supplies last. Non-transferable. Original coupon must be presented. Valid through 7/12/13. Limit one coupon per customer per day.

drillmaster **10" SLIDING COMPOUND MITER SAW**
CHICAGO ELECTRIC POWER TOOLS
LOT NO. 98199

SAVE \$70

\$7999
REG. PRICE \$149.99

LIMIT 5 - Good at our stores or website or by phone. Cannot be used with other discount or coupon or prior purchases after 30 days from original purchase with original receipt. Offer good while supplies last. Non-transferable. Original coupon must be presented. Valid through 7/12/13. Limit one coupon per customer per day.

drillmaster **2 HP FIXED BASE ROUTER**
LOT NO. 68341

SAVE 25%

\$4499
REG. PRICE \$59.99

LIMIT 3 - Good at our stores or website or by phone. Cannot be used with other discount or coupon or prior purchases after 30 days from original purchase with original receipt. Offer good while supplies last. Non-transferable. Original coupon must be presented. Valid through 7/12/13. Limit one coupon per customer per day.

WINDSOR DESIGN **EIGHT DRAWER WOOD TOOL CHEST**
LOT NO. 94538

SAVE \$40

\$5999
REG. PRICE \$99.99

Tools sold separately.

LIMIT 4 - Good at our stores or website or by phone. Cannot be used with other discount or coupon or prior purchases after 30 days from original purchase with original receipt. Offer good while supplies last. Non-transferable. Original coupon must be presented. Valid through 7/12/13. Limit one coupon per customer per day.

CENTRAL PNEUMATIC **2.5 HP, 21 GALLON, 125 PSI VERTICAL AIR COMPRESSOR**
LOT NO. 67847/69091

SAVE \$70

\$14999
REG. PRICE \$219.99

Item 67847 shown

LIMIT 4 - Good at our stores or website or by phone. Cannot be used with other discount or coupon or prior purchases after 30 days from original purchase with original receipt. Offer good while supplies last. Non-transferable. Original coupon must be presented. Valid through 7/12/13. Limit one coupon per customer per day.

CHICAGO ELECTRIC POWER TOOLS **18 VOLT CORDLESS 1/2" DRILL/DRIVER WITH KEYLESS CHUCK**
LOT NO. 68850

SAVE 33%

\$3999
REG. PRICE \$59.99

NEW!

18V NiCd battery and charger included.

LIMIT 3 - Good at our stores or website or by phone. Cannot be used with other discount or coupon or prior purchases after 30 days from original purchase with original receipt. Offer good while supplies last. Non-transferable. Original coupon must be presented. Valid through 7/12/13. Limit one coupon per customer per day.

WINDSOR DESIGN **60" WORKBENCH WITH FOUR DRAWERS**
LOT NO. 93454/69054

SAVE \$90

\$13999
REG. PRICE \$229.99

Item 93454 shown

LIMIT 4 - Good at our stores or website or by phone. Cannot be used with other discount or coupon or prior purchases after 30 days from original purchase with original receipt. Offer good while supplies last. Non-transferable. Original coupon must be presented. Valid through 7/12/13. Limit one coupon per customer per day.

CENTRAL MACHINERY **2 HP INDUSTRIAL 5 MICRON DUST COLLECTOR**
LOT NO. 97869

SAVE \$100

\$14999
REG. PRICE \$249.99

LIMIT 3 - Good at our stores or website or by phone. Cannot be used with other discount or coupon or prior purchases after 30 days from original purchase with original receipt. Offer good while supplies last. Non-transferable. Original coupon must be presented. Valid through 7/12/13. Limit one coupon per customer per day.

drillmaster **ORBITAL PALM SANDER**
LOT NO. 40070

SAVE 55%

\$899
REG. PRICE \$19.99

LIMIT 8 - Good at our stores or website or by phone. Cannot be used with other discount or coupon or prior purchases after 30 days from original purchase with original receipt. Offer good while supplies last. Non-transferable. Original coupon must be presented. Valid through 7/12/13. Limit one coupon per customer per day.

Lifetime CARBIDE **ALUMINUM OXIDE SANDING SPONGES - PACK OF 10**
LOT NO. 46751

SAVE 41%

\$349
REG. PRICE \$5.99

YOUR CHOICE!
COARSE
MEDIUM
FINE

LIMIT 9 - Good at our stores or website or by phone. Cannot be used with other discount or coupon or prior purchases after 30 days from original purchase with original receipt. Offer good while supplies last. Non-transferable. Original coupon must be presented. Valid through 7/12/13. Limit one coupon per customer per day.

PITTSBURGH **3 TON HEAVY DUTY JACK STANDS**
LOT NO. 38846/69597

SAVE 54%

\$1599
REG. PRICE \$34.99

Item 38846 shown

LIMIT 5 - Good at our stores or website or by phone. Cannot be used with other discount or coupon or prior purchases after 30 days from original purchase with original receipt. Offer good while supplies last. Non-transferable. Original coupon must be presented. Valid through 7/12/13. Limit one coupon per customer per day.

SUPER COUPON!

12" RATCHET BAR CLAMP/SPREADER

PITTSBURGH



Item 46807 shown

SAVE 63%

LOT NO. 46807/68975/69221/69222

\$199 REG. PRICE \$5.49

39368005

LIMIT 9 - Good at our stores or website or by phone. Cannot be used with other discount or coupon or prior purchases after 30 days from original purchase with original receipt. Offer good while supplies last. Non-transferable. Original coupon must be presented. Valid through 7/12/13. Limit one coupon per customer per day.

SUPER COUPON!

12" COMBINATION SQUARE SET

PITTSBURGH



LOT NO. 92471

SAVE 50%

12689000

\$499 REG. PRICE \$9.99

LIMIT 9 - Good at our stores or website or by phone. Cannot be used with other discount or coupon or prior purchases after 30 days from original purchase with original receipt. Offer good while supplies last. Non-transferable. Original coupon must be presented. Valid through 7/12/13. Limit one coupon per customer per day.

SUPER COUPON!

4 PIECE 1" x 15 FT. RATCHETING TIE DOWN SET

LOT NO. 90984/60405



Item 90984 shown

SAVE 52%

\$799 REG. PRICE \$16.99

80015035

LIMIT 9 - Good at our stores or website or by phone. Cannot be used with other discount or coupon or prior purchases after 30 days from original purchase with original receipt. Offer good while supplies last. Non-transferable. Original coupon must be presented. Valid through 7/12/13. Limit one coupon per customer per day.

SUPER COUPON!

NITRILE GLOVES PACK OF 100

WESTERN SAFETY



5 MIL. THICKNESS

Item 68498 shown

YOUR CHOICE!

\$599 REG. PRICE \$9.99

LOT NO. 68496
MEDIUM
LOT NO. 68497/97582
LARGE
LOT NO. 68498/37052/97583
X-LARGE

94888001

LIMIT 8 - Good at our stores or website or by phone. Cannot be used with other discount or coupon or prior purchases after 30 days from original purchase with original receipt. Offer good while supplies last. Non-transferable. Original coupon must be presented. Valid through 7/12/13. Limit one coupon per customer per day.

SUPER COUPON!

14" OSCILLATING SPINDLE SANDER

CENTRAL MACHINERY



Item 95088 shown

SAVE \$60

LOT NO. 95088/69257

\$8999 REG. PRICE \$149.99

15207620

LIMIT 5 - Good at our stores or website or by phone. Cannot be used with other discount or coupon or prior purchases after 30 days from original purchase with original receipt. Offer good while supplies last. Non-transferable. Original coupon must be presented. Valid through 7/12/13. Limit one coupon per customer per day.

SUPER COUPON!

16" x 30" STEEL SERVICE CART

US GENERAL



Item 5107 shown

SAVE 37%

220 LB. CAPACITY

\$2799 REG. PRICE \$44.99

70846430

LIMIT 3 - Good at our stores or website or by phone. Cannot be used with other discount or coupon or prior purchases after 30 days from original purchase with original receipt. Offer good while supplies last. Non-transferable. Original coupon must be presented. Valid through 7/12/13. Limit one coupon per customer per day.

SUPER COUPON!

4 PIECE WOOD CHISEL SET

Item 42429 shown



1" 3/4" 1/2" 1/4"

SAVE 43%

LOT NO. 42429/69471

\$449 REG. PRICE \$7.99

990258448

LIMIT 9 - Good at our stores or website or by phone. Cannot be used with other discount or coupon or prior purchases after 30 days from original purchase with original receipt. Offer good while supplies last. Non-transferable. Original coupon must be presented. Valid through 7/12/13. Limit one coupon per customer per day.

SUPER COUPON!

4" x 36" BELT/6" DISC SANDER

CENTRAL MACHINERY



Item 97181 shown

SAVE \$45

LOT NO. 97181/93981

\$5499 REG. PRICE \$99.99

48213732

LIMIT 3 - Good at our stores or website or by phone. Cannot be used with other discount or coupon or prior purchases after 30 days from original purchase with original receipt. Offer good while supplies last. Non-transferable. Original coupon must be presented. Valid through 7/12/13. Limit one coupon per customer per day.

SUPER COUPON!

90 AMP FLUX WIRE WELDER

CHICAGO ELECTRIC WELDING



NO GAS REQUIRED!

Item 68887 shown

SAVE \$60

LOT NO. 68887

\$8999 REG. PRICE \$149.99

85716593

LIMIT 4 - Good at our stores or website or by phone. Cannot be used with other discount or coupon or prior purchases after 30 days from original purchase with original receipt. Offer good while supplies last. Non-transferable. Original coupon must be presented. Valid through 7/12/13. Limit one coupon per customer per day.

SUPER COUPON!

16" VARIABLE SPEED SCROLL SAW

CENTRAL MACHINERY



Item 93012 shown

SAVE 25%

LOT NO. 93012

\$5999 REG. PRICE \$79.99

35557018

LIMIT 5 - Good at our stores or website or by phone. Cannot be used with other discount or coupon or prior purchases after 30 days from original purchase with original receipt. Offer good while supplies last. Non-transferable. Original coupon must be presented. Valid through 7/12/13. Limit one coupon per customer per day.

SUPER COUPON!

45 WATT SOLAR PANEL KIT

THUNDERBOLT solar



Item 68751 shown

SAVE \$90

LOT NO. 68751/90599

\$13999 REG. PRICE \$229.99

93275670

LIMIT 5 - Good at our stores or website or by phone. Cannot be used with other discount or coupon or prior purchases after 30 days from original purchase with original receipt. Offer good while supplies last. Non-transferable. Original coupon must be presented. Valid through 7/12/13. Limit one coupon per customer per day.

SUPER COUPON!

6.5 HP OHV HORIZONTAL SHAFT GAS ENGINES (212 CC)

PREDATOR ENGINES



Item 68120 shown

SAVE \$80

LOT NO. 68120/69730/60363
LOT NO. 68121/69727, CALIFORNIA ONLY

\$9999 REG. PRICE \$179.99

15207662

LIMIT 4 - Good at our stores or website or by phone. Cannot be used with other discount or coupon or prior purchases after 30 days from original purchase with original receipt. Offer good while supplies last. Non-transferable. Original coupon must be presented. Valid through 7/12/13. Limit one coupon per customer per day.

SUPER COUPON!

70 dB Noise Level

SUPER QUIET!

3200 RATED WATTS/4000 MAX. WATTS PORTABLE GENERATORS (212 CC)

PREDATOR GENERATORS



Item 68528 shown

SAVE \$160

LOT NO. 68528/69676/69729
LOT NO. 68527/69675/69728, CALIFORNIA ONLY

\$28999 REG. PRICE \$449.99

801461104

LIMIT 3 - Good at our stores or website or by phone. Cannot be used with other discount or coupon or prior purchases after 30 days from original purchase with original receipt. Offer good while supplies last. Non-transferable. Original coupon must be presented. Valid through 7/12/13. Limit one coupon per customer per day.

SUPER COUPON!

SAVE \$60

RAPID PUMP® 2.5 TON HEAVY DUTY STEEL FLOOR JACK

PITTSBURGH



Item 68049 shown

WEIGHS 77 LBS.

• Low Profile

LOT NO. 68049/60688

\$6999 REG. PRICE \$129.99

55512129

LIMIT 5 - Good at our stores or website or by phone. Cannot be used with other discount or coupon or prior purchases after 30 days from original purchase with original receipt. Offer good while supplies last. Non-transferable. Original coupon must be presented. Valid through 7/12/13. Limit one coupon per customer per day.

SUPER COUPON!

SAVE 42%

3" HIGH SPEED ELECTRIC CUT-OFF TOOL

CHICAGO ELECTRIC POWER TOOLS



Item 68523 shown

Lot No. 68523/60415

Cutting disc sold separately.

\$1999 REG. PRICE \$34.99

90475562

LIMIT 3 - Good at our stores or website or by phone. Cannot be used with other discount or coupon or prior purchases after 30 days from original purchase with original receipt. Offer good while supplies last. Non-transferable. Original coupon must be presented. Valid through 7/12/13. Limit one coupon per customer per day.

E-mail it to us at askwood@woodmagazine.com. For faster feedback from your fellow woodworkers, search for or post your question in the **Ask WOOD Online** section of woodmagazine.com/askwood, or on one of our topical woodworking forums at woodmagazine.com/forums. You can also snail-mail questions to Ask WOOD, 1716 Locust St, LS-221, Des Moines, IA 50309-3023.

Stop the bleeding for crisp, colorful creations

For Christmas gifts, I decided to make two Chinese checker boards (from issue 186, Oct. 2008). But when I spray-painted the triangles on the plywood game board, the paint leached along the wood fibers [Photo A], messing up the crisp edges I was striving for. Where did I go wrong?

—Julie Penders, Fort Collins, Colo.

I'd like to make a Chinese checker board, but instead of painting the triangles I want to stain them with wood tones. How can I do this without the stain bleeding outside the triangles?

—Gary Wilson, McComb, Miss.

The answers to both dilemmas are similar. Julie, to stop paint from leaching outside the boundaries—defined only by masking tape—seal the bare plywood surface with three

coats of either lacquer [Photo B] or dewaxed shellac, also known as sanding sealer, before spraying any paint. After this has dried, mask off the triangles and spray with paint [Photo C]; because the paint can't penetrate the sealed wood, it can't spread. After the paint has dried, top the game board with a clear-coat finish. Most of these will adhere nicely to the sealer and paint; but beware that lacquer will peel non-lacquer-based paint, so test first on scrap or simply topcoat with polyurethane to be safe.

Now, for Gary's staining idea: You can't seal the plywood first, because that would prevent stain from penetrating and binding with the wood. So instead, begin by scoring the triangle boundaries with a sharp marking knife or utility knife [Photo D], just deep enough to sever the surface veneer fibers. Then apply small amounts of stain with a fine artist's brush [Photo E], gradually working your way toward the scored edges and letting the stain wick its way ahead of the brush. Penetrating, oil-based stain—not gel stain—works best here, because you won't be able to wipe off any excess without messing up the board. Once you've stained all six triangles and allowed the game board to dry, top-coat with three or four layers of polyurethane, lacquer, or shellac.

continued on page 68

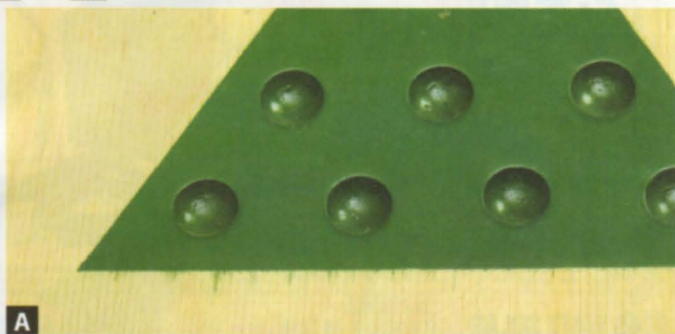

A



B



C

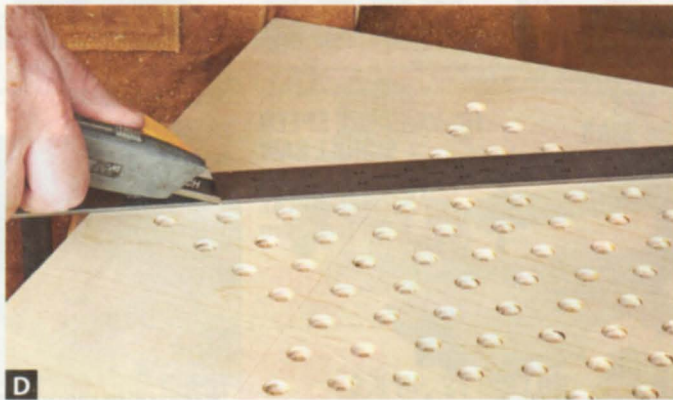

D

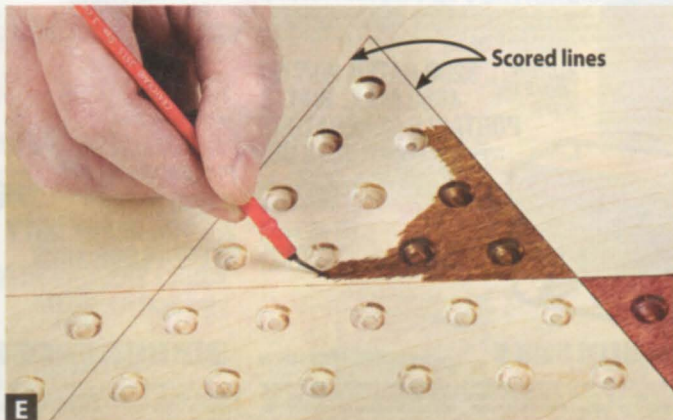

E

The facts are hard to ignore.

Titebond® III outperforms polyurethane glues.

Reference Guide

Glue comparison

What woodworkers need to know!

	Titebond III	Polyurethane Glues
Higher Bond Strength	✓	✓
Exterior Use – Waterproof	✓	
Easy Water Cleanup	✓	
Much Safer To Use	✓	
Shorter Clamp Time	✓	
No Foam – Less Mess	✓	
Shorter Open Time	✓	✓
Doesn't Stain Skin	✓	✓
Bonds Most Materials	✓	
Bonds Oily / Exotic Woods	✓	
Lower Cost – Better Value	✓	
Longer Usable Shelf Life	✓	

Woodworking Handbook 2007



As the leader in wood glues, we want you to know the truth about polyurethane glue and woodworking. A straightforward comparison between Titebond® III Ultimate Wood Glue and polyurethane glue tells the story.

Titebond® III is THE ultimate choice for bonding wood to wood. Period.



www.titebond.com/TBIIIvsPolyurethane

Made in the USA

The Finest Woods

Lumber • Veneer • Turning Stock



- ✓ Expert advice
- ✓ 100 woods in stock
- ✓ Hand selected orders
- ✓ 100% satisfaction

Order your favorite woods quickly & securely at our website:

www.101woods.com

VISA PayPal



800-423-2450

Born in the USA

Beautiful but rugged. Eagle America router bits cut clean and like to stay on the job. We don't cut corners and it shows. It's all in the bit.



www.EagleAmerica.com
(800) 872-2511



Ask WOOD

Smoothing out the hole story

For years I've used a Bosch 5" random-orbit sander, and recently added a 6" Bosch to my shop. But while buying hook-and-loop sanding discs for the new tool, I noticed it has a six-hole pattern, compared to the eight-hole pattern on the smaller sander. Doesn't it stand to reason that a larger sander—which removes more material—would need more holes to suck up the dust?

—Jeff Crowley, Davis, Calif.

Good catch, Jeff. According to Jim Stevens, Bosch's longtime product manager for woodworking power tools, Bosch sanders decades ago used pressure-sensitive-adhesive (PSA) discs with five holes for 5" models and six holes for 6". In 1989, Bosch—and, later, other manufacturers—began using hook-and-loop pads and abrasives with an eight-hole pattern for 5" sanders to make disc changes easier and improve dust-collection efficiency.

But Bosch's 6" sanders never changed from the six-hole pattern, even when switching to hook-and-loop pads, because, Jim says, the larger motor and blower collect dust well enough to not warrant an upgrade.

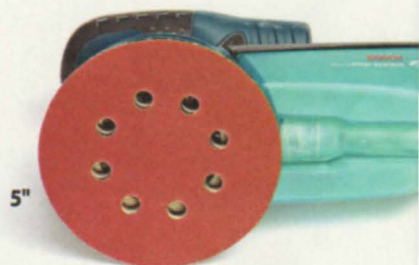

5"

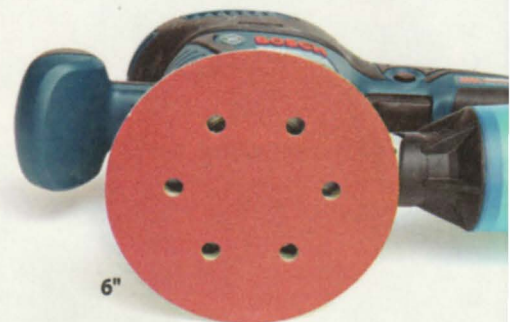

6"

continued on page 70



Become a better woodworker in one weekend.

“Weekend With **WOOD**” is three days of intensive, up-close sessions taught by master woodworkers Marc Adams, Gary Rogowski, Jim Heavey, George Vondriska, Tom McLaughlin, and more. **You** choose the topics of most interest to you.

- ✓ Small classes taught by world-class woodworkers
- ✓ Held at **WOOD** world headquarters in Des Moines, Iowa
- ✓ Free “swag bag” of woodworking goodies worth more than \$200
- ✓ Dozens of door prizes

Weekend With **WOOD**[™] May 17–19, 2013

Tuition: \$525

Attendance limited to the first 200 registrants!

Learn more at woodmagazine.com/weekendwithwood or call 888-636-4478.

SPONSORED BY:



Turn Your Single Stage Dust Collector into a Super Cyclonic Collector!

The New Super Dust Deputy!

No more clogged filters!



Collector, Hoses and Drum Not Included.

Introductory Price

Only **\$169.00**
Cyclone Only
Reg. \$199.00

99%+ of waste ends up in drum.

- New innovative cyclone design separates 99%+ of wood waste before the filter. Helps maintain consistent airflow.
- Retrofits to single stage 1/2hp to 3hp dust collectors.
- Compact size: Approx. 27" H x 18" Dia. Inlet - 5" / Outlet - 6" - Static Conductive Plastic



Made in USA

Dust Deputy[®] Deluxe

Only **\$89.00**

Turn your wet / dry vacuum into a super cyclonic collector!

Retrofits to any vac!

See the entire family of Dust Deputy's on our website.



Pat. # 7,262,074

Like Dust Collection Systems and Components Since 1993.

Call Today for **FREE** Catalog!
1.800.732.4065
www.oneida-air.com



Dust Collection Since 1993.

Ask WOOD

A pesky pin problem

There's a pin on the edge of my bandsaw table that keeps snagging my shirt. And it gets in the way during blade changes. Can I just remove it altogether?

—Paul Barger, Portsmouth, N.H.

Sorry, Paul, but that support pin blocks the blade-access slot for a very good reason. Cast iron is softer than most people realize, and the long blade-access slot actually weakens the table. The support pin keeps the two sides of the table rigid and on the same plane. Left unsupported, the table can rack unevenly as heavy pieces move across it.

To keep from snagging your shirt on the protruding pin handle, try wrapping the pin in a shop towel and then covering that with duct tape extending to the corners of the table edges. 🌱



Often tapered for a friction fit, many support pins offer quick removal to allow use of the blade-access slot. Threaded pins with recessed heads take longer to remove, but won't snag your clothes.

SAVE When You Grow A Zoysia Lawn From Plugs!

From Plugs

To A Fabulous Lawn



Zoysia Lawns are thick, dense and lush!

GRASS SEED WILL NEVER GROW A LAWN LIKE THIS!
Save Water! Save Time! Save Work! Save Money!

Grass Seed Is For The Birds!

Stop wasting money, time and work sowing new grass seed each spring, only to see birds eat the seed – or rain wash it away – before it can root. Plant a genuine Amazoy™ Zoysia lawn from our living Plugs only once... and never plant a new lawn again!



Zoysia thrives in partial shade to full sun!

Zoysia Grows Where Other Grass Doesn't!

Zoysia is the perfect choice for hard-to-cover spots, areas that are play-worn or have partial shade, and for stopping erosion on slopes. North, South, East, West – Zoysia will grow in any soil, no ifs, ands or buts!

Each Zoysia Plug You Plant In Your Soil Is **GUARANTEED TO GROW** Within 45 Days Or We'll Replace It FREE!

To ensure best results, we ship you living sheets of genuine Amazoy™ Zoysia Grass, harvested direct from our farms. Plugs are not cut all the way through. Before planting, simply finish the separation by cutting T-sq. Plugs with shears or knife. Then follow the included easy instructions to plant Plugs into small plug holes about a foot apart. Our guarantee and planting method are your assurance of lawn success backed by more than 5 decades of specialized lawn experience.

©2013 Zoysia Farm Nurseries, 3617 Old Taneytown Rd, Taneytown, MD 21787

Eliminates Endless Weeds And Weeding!

No more pulling out weeds by hand or weeds sprouting up all over your lawn. Zoysia Plugs spread into a dense, plush, deep-rooted, established lawn that drives out unwanted growth and stops crab-grass and summer weeds from germinating.

Environmentally Friendly, No Chemicals Needed!

No weeding means no chemicals. You'll never have to spray poisonous pesticides and weed killers again! Zoysia lawns are safer for the environment, as well as for family and pets!

Cuts Watering & Mowing By As Much As 2/3!

Many established Zoysia lawns only need to be mowed once or twice a season. Watering is rarely, if ever, needed – even in summer!



We slip at the best planting time for you!

Meyer Zoysia Grass was perfected by the U.S. Gov't, released in cooperation with the U.S. Golf Association as a superior grass.

www.ZoysiaFarms.com/mag

Stays Green In Summer Through Heat & Drought!

When ordinary lawns brown up in summer heat and drought, your Zoysia lawn stays green and beautiful. The hotter it gets, the better it grows. Zoysia thrives in blistering heat (120°), yet it won't winter-kill to 30° below zero. It only goes off its green color after killing frosts, but color returns with consistent spring warmth. Zoysia is the perfect choice for water restrictions and drought areas!

Our Customers Love Their Zoysia Lawns!

One of our typical customers, Mrs. M.R. Mitter of PA, wrote how "I've never watered it, only when I put the Plugs in... Last summer we had it mowed 2 times... When everybody's lawns here are brown from drought, ours just stays as green as ever!"

Order Now And Save!

The more Amazoy™ Zoysia Plugs you order, the more you SAVE! And remember, once your Zoysia lawn is established, you'll have an endless supply of new Plugs for planting wherever you need them. Order now!

FREE! PLANTING TOOL

With Order of 500 Plugs or More!

Saves time, work and effort when making holes for Plugs!

Order Now and Save Over 50% – Harvested Daily From Our Farms And Shipped To You Direct!

FREE Shipping On Larger Quantities!
Get Up To 900 Plugs — FREE!

Please send me guaranteed Amazoy plug packs as marked:

Quantity	# PLUGS	+FREE Plugs	Your PRICE	+ Shipping	YOU SAVE	+FREE Planting Tool
	150	—	\$ 14.95	\$ 5.00	—	—
	500	+ 100	\$45.60	\$ 7.00	\$27.20	Free Step-on Plugger
	750	+ 150	\$74.50	\$10.00 FREE	\$45.20	Free Step-on Plugger
	1100	+ 400	\$99.10	\$15.00 FREE	\$100.40	Free Amazoy Power Auger
	1500	+ 900	\$147.50	\$25.00 FREE	\$171.70	Free Amazoy Power Auger AND Step-on Plugger

Extra Step-on Plugger \$8.95 + \$3 Shipping Extra Amazoy Power Auger™ for 3/8" Drill \$24.95 + \$5 Shipping

Mail to: **ZOYSIA FARM NURSERIES**
 3617 Old Taneytown Road, Taneytown, MD 21787

Dept. 5177

Write price of order here \$ _____ Payment method (check one)

Md. residents add 6% tax \$ _____ Check MO

Shipping \$ _____ MasterCard

ENCLOSED TOTAL \$ _____ Visa

Card # _____ Exp. Date _____

Name _____

Address _____

City _____ State _____

Zip _____ Phone _____

We ship all orders the same day plugs are packed at earliest correct planting time in your area.

Amazoy is the trademark registered U.S. Patent Office for our Meyer Zoysia grass.

Order Now! www.ZoysiaFarms.com/mag

Not shipped outside the USA or into WA or OR

Shop-Proven Products

These woodworking wares passed our shop trials.

Mini cyclone makes a clean sweep as a small-shop dust collector

When we tested the dust collectors on page 58, we also ran Delta's new mini cyclone through the same paces to see how it measures up. Based on our testing, this portable unit would be a great choice if centrally located in the duct network of a small basement or garage shop, or connected to just a few machines with flex-hose (10' or shorter). It's compact (68" tall), reasonably quiet (80 decibels), and generates respectable airflow (overcoming nearly 4" of static-pressure loss at 800 CFM). And its cyclone separator and 1-micron-rated canister filter trapped more fine dust particles than several collectors that cost more money.

But our favorite feature is the chip-collection drum. To empty it, you simply lift a lever to lower the drum away from its lid, slide it out on its casters, and then lift the disposable collection bag and toss it. We'd like to

see more manufacturers adopt this kind of convenience.

The 50-905 runs on a 1½-hp, 220-volt soft-start motor. A remote control makes it easy to turn on and off, and a four-setting timer lets you run it after you've left the shop, further cleaning the air (with a few blast gates open). There's also a handy floor sweep that attaches to the inlet for quick cleanups.

—Tested by Doug Ley and Tom Brumback



Portable cyclone dust collector (50-905)

Performance ★★★★★

Price \$1,350

Delta Machinery
800-223-7278;
deltamachinery.com



About our product tests

We test hundreds of tools and accessories, but only those that earn at least three stars for performance make the final cut and appear in this section of our magazine. The products shown here, and those that don't make the cut, are also reviewed at toolreviews.woodmagazine.com. Prices shown are current at the time of article production and do not include shipping, where applicable.



WISE BUYS: Countersinking drill bit sets

In one drilling motion, countersinking drill bit sets bore a pilot hole, a countersink for the screw head, and, if you plunge a little

deeper, a counterbore to accommodate a wood plug. We recommend these three sets for different users and applications.

Best for traditional wood screws



Lee Valley
8-piece set, no. 07J15.80, \$109
800-871-8158; leevalley.com

Tapered pilot holes grip the entire length of traditional wood screws. But tapered bits must run at about 250 rpm to avoid burning, and they tend to clog. Lee Valley's bits cut fastest with less tear-out and clogging than other tapered sets we tested. This 8-piece set drills holes for #4–14 screws with ⅜" and ½" counterbores.

Best for longevity



Amana Tool
5-piece carbide-tipped set, no. PS-500, \$100
800-445-0077; amanatool.com

The only set we tested with durable carbide-tipped countersinks, they cut quickly, cleanly, and without chatter. The set comes with its own plug cutter to match the 10mm counterbore produced by each of the four bits sized for #8–14 production screws (though we wish they went down to #4). Amana also sells tapered versions of these bits for \$25 apiece.

Best on a budget



Insty-Bit
5-piece set, no. 82501, \$25
612-381-1060; insty-bit.com

Nothing exotic here: just twist bits in steel cutters sized for #4–12 screws. In our tests, every piece in the set cut clean countersinks and ⅜" or ½" counterbores in quick fashion. As a nice touch, the manufacturer stamps the countersinks with the size of the matching bit. The ¼" hex shanks make for quick in-and-out connection in any hex-chuck drill/driver.

continued on page 74



The DR® POWERWAGON is a
Self-Propelled **EASY HAULER**

Sized and Priced for Homeowners!

HAULS UP TO 800 LBS. – firewood...mulch... gravel...stone. Powers up hills and down... even through soft, wet soil!

ELECTRIC-START and powered dump options available.

EASY TO USE! Rear caster and differential drive for easy turning...4 speeds, reverse, dump-bed, hand brake all included.

Call for a FREE DVD and Catalog!

77700X © 2013

TOLL-FREE
888-213-2037
DRpowerwagon.com



For the Serious Gardener



DR® ROTO-HOG™ POWER TILLER

FAR FASTER & EASIER to use than hard-to-handle, walk-behind tillers.

TILLS A 3-FOOT SWATH with each pass — twice the width of most walk-behind tillers!

BIG ENGINE POWER is ideal for large gardens, landscape projects, and food plots.

CREATE PERFECT SEEDBEDS with the smooth and deep-tilling action of 24 steel bolo tines.



77701X © 2013

Call for a FREE DVD and Catalog!

TOLL-FREE
888-213-2037
DRrototiller.com



Tows behind your
ATV or Lawn Tractor!

Turn A Rough Driveway Into A Smooth Ride.

DR® POWER GRADER

PATENTED DESIGN easily fills in potholes, smoothes washboard.

POWERED ACTUATOR controls grading depth with a remote control.

LOOSENS AND REDISTRIBUTES composite driveway surfaces without the need to haul, shovel, or rake new material.

CARBIDE-TIPPED SCARIFYING teeth loosen the hardest surfaces.



77702X © 2013

Call for a FREE DVD and Catalog!

TOLL-FREE
888-213-2037
DRpowergrader.com



The Easier Way To Trim and Mow!

The original, patented DR® TRIMMER/MOWER

TRIM within a whisker of houses, trees, fences. Big wheels make it easy for anyone to control precisely!

MOW WITHOUT FEAR of hitting rocks or hidden obstacles, because there's no blade to bend or dull.

GUARANTEED NOT TO TANGLE even in waist-high grass and weeds — thanks to its patented No-Wrap Trimmer Head.



77697X © 2013

Call for a FREE DVD and Catalog!

TOLL-FREE
888-213-2037
DRtrimmer.com



NEW Lower-Priced Models!



PATENT PENDING

WORLD'S FASTEST SPLITTER!

ONE LOG, ONE SECOND.

77698X © 2013

The new DR® RapidFire™ Log Splitter slices through logs in under two seconds—up to six times faster than ordinary log splitters. We've replaced hydraulics with two hefty cast iron flywheels that generate massive splitting force. Split dense hardwoods up to 30" in diameter.



TOLL-FREE
888-213-2037
DRlogsplitters.com



SELF-FEEDING DR® CHIPPER!

Just load a DR® RAPID-FEED™ CHIPPER, step back, and watch it chip branches up to 5½" thick!

SELF-FEEDING saves time and energy. Most branches can be dropped into the hopper and will self-feed, instead of you having to force-feed them.

POWERFUL ENGINES up to 18 HP.

TRACTOR OWNERS!

3-Point Hitch, tractor-mounted models also available.



77699X © 2013

Call for a FREE DVD and Catalog!

TOLL-FREE
888-213-2037
DRchipper.com



Shop Proven Products

Cutting with this lightweight circular saw is a breeze

As a trim carpenter and remodeler, I appreciate what DeWalt's engineers did with this saw: They made it light (8½ lbs) and easy to use. That's a pound less than DeWalt's next-lightest 7¼" circ saw and nearly 4 lbs less than its heavy-duty model. And they did it without turning the tool into a toy. The aluminum base has been plenty durable for my needs, and the 15-amp motor packs enough punch to plow through treated pine, OSB laminated joists, and even 8/4 oak.

I'm not normally a bells-and-whistles guy, but what I like best about this saw is its integrated dust blower. The motor fan discharges air in front of the blade, blowing dust and chips off the cutline so I can clearly see and follow pencil marks and chalklines. Nice!

—Tested by Dave Fish



7¼" circular saw (DWE575)

Performance

★★★★☆

Price

\$129

DeWalt

800-433-9258; dewalt.com



continued on page 76

WOOD magazine May 2013



Metal Corbels & Brackets



Table Slides & Apron Kits



Fusion Legs



Osborne Wood Products, Inc has a large selection of wood turnings and components. Visit us online to see our product offerings and place your order.

- Table and Island Legs
- Bun Feet
- Corbels
- Moldings
- and much more!

866.963.5580
WWW.BUN-FEET.COM



Scan the code to visit our homepage

EFFORTLESS OUTDOOR CLEANUP!



WITH THE POWER OF A Cyclone Rake

The Cyclone Rake hitches to any riding mower or ZTR. Its powerful engine-driven vacuum-mulcher delivers 10 times the lifting power of mowers and many times the hauling capacity. Clear acres of grass, overgrown fields, tons of fall leaves, sticks and lawn debris with ease. And when you're done it folds up flat, just 8 inches thick and hangs right on the wall.



FOLDS UP FLAT!

Backed by a 12-month risk-free return and a 3-year warranty.

REQUEST A FREE, CATALOG AND DVD

1-800-592-7557

or visit CycloneRake.com

 Like us on Facebook

 Follow us on Twitter

Mention the Discount Code **WM413** when you call, or enter it on our web site for a special discount on any Cyclone Rake model. (Expires 12/27/2013)

©2013 Woodland Power Products, Inc., 72 Acton St., West Haven, CT 06516

Save up to **50%** or more on heating costs



Made in the USA

envi™
wall-mounted room heater

consumes less. warms more.

- energy saving** heats a room for only 4 cents per hour!
- ultra-safe** leave unattended 24/7, cool to touch
- healthy** fanless - will not circulate dust or dry the air
- effective** 100% Pure Stack Convection, gentle whole room warmth!
- silent** fanless design, auto dimming power light
- easy install** installs in minutes, no drill required
hardwired and plug-in models available
- stylish** slim space saving design
only 19" wide by 2" thin!

economical. safe. simple.

eheat.com

1-800-807-0107

Free Shipping On all Orders!

Limited Time 10% Discount! Coupon Code: WOOD13A10

CherryTree Wildwood

Woodworking Plans, Kits & Supplies

Since 1981



www.CherryTreeToys.com

12446 W State Rd 81 • Beloit, WI 53511

1-800-848-4363

Forrest Blades

For building cabinets and fine furniture, nothing beats Forrest saw blades.

Craftsmen appreciate the way our blades deliver smooth, quiet cuts without splintering, scratching, or tearouts. They know our unique grade C-4 micrograin carbide, proprietary manufacturing process, and hand straightening produce exceptional results. In fact, independent tests rate us #1 for rip cuts and crosscuts.

"From the first cut on, I realized that this blade was a bargain at any price! Nothing else I have cuts comparably."
Calvin Brodie, Spanaway, WA

Forrest Quality Shows

Woodworker II—Best rated, all-purpose blade for rips and crosscuts.

Chop Master—Perfect for tight, perfectly cut miter joints without splinters.



Order from any Forrest dealer or retailer, online, or by calling directly. Our blades are manufactured in the U.S.A. and backed by our 30-day, money-back guarantee.

FORREST

The First Choice of Serious Woodworkers Since 1946

www.ForrestBlades.com

1-800-733-7111

(In NJ, call 973-473-5236)

Code WM

© 2013 Forrest Manufacturing

Shop Proven Products

Flatten hand tools and sharpening stones fast

As a big fan of hand tools—some co-workers accuse me of never plugging in a tool—I really appreciate how DMT's Dia-Flat lapping plate saves me time when flattening and sharpening chisels, planes, and plane irons. This 4×10" diamond-coated steel bar lets me flatten a new plane's sole or dished-out waterstones, ceramic stones, and even hard-as-a-rock (pun intended) oilstones in less time than it takes with other lapping media. And without flat stones, you'll never put a perfect edge onto your tools.

The 120-grit diamond abrasive cuts quickly without clogging, and doesn't leave deep scratches. After using it, I simply rinse it off, pat it with a towel, and allow it to air-dry to prevent rust. Best of all, after months of use it still cuts as fast and effectively as it did when new.

—Tested by John Olson, Design Editor



Dia-Flat diamond lapping plate

Performance ★★★★★
Price \$200

DMT
800-450-2172; dmtsharp.com



continued on page 78

The Versatile Lumber Maker!

Saw Lumber For Your Own:

- Home • Furniture • Picnic Tables • Barns
- Gazebo • Flooring • Decking • Stables



1-800-473-4804
WWW.COOKSSAW.COM

ONLY
1,639 in our vault



It's a first. It's silver. It's patriotic. And it's a steal.

Washington crossing the Delaware.
Eisenhower launching D-Day.
Kennedy rescuing the crew of PT
109. These men made history.

This set made history

To celebrate the bicentennial of America, the U.S. Mint struck this special three-piece proof set honoring these three American presidents—and our 200th birthday. To capture the bicentennial spirit, the coins in the set are dual-dated 1776–1976.

This set was so popular over 4 million were sold.

Unlike the regular circulating coins of the day, these coins are struck in 40% precious silver.

It's the first commemorative U.S. Mint Proof Set ever. It's also the first proof set to feature all dual-dated coins. And finally, it's the first U.S. Proof Set to include a Silver Dollar.

Americans love proof coins from the U.S. Mint. Each coin is struck twice from specially prepared dies and has deeply-mirrored surfaces and superb frosty images.

And you know you've got a *real piece of American history* when you hold this set—the red white and blue holder is spectacular!

Now for the steal part...

This first-ever Bicentennial Silver Proof Set sold out at the mint three decades ago. When you consider how much prices have risen since then, you might expect to pay \$100 or more to buy this set today.

But for this special offer, we are releasing our entire stock of Bicentennial Silver Proof Sets for only \$49 each. *Or better yet, buy five and pay only \$39 each!*

Order now risk free

We expect our small quantity of Bicentennial Silver Proof Sets to disappear quickly at this special price. We urge you to call now to get yours. You must be satisfied with your set or return it within 30 days of receipt for a prompt refund (less s&h).

Buy more and SAVE

1776-1976 Bicentennial Silver Proof Set \$49 + s/h
5 for only \$39 each + s/h **SAVE \$50**

Toll-Free 24 hours a day

1-800-558-6468

Offer Code BPF271-05

Please mention this code when you call.

 **GOVMINT.COM**
YOUR ONE BEST SOURCE FOR COINS WORLDWIDE

14101 Southcross Drive W.
Dept. BPF271-05
Burnsville, Minnesota 55337
www.GovMint.com

Prices and availability subject to change without notice. Past performance is not a predictor of future performance. NOTE: GovMint.com® is a private distributor of worldwide government coin and currency issues and privately issued licensed collectibles and is not affiliated with the United States government. Facts and figures deemed accurate as of July 2012. ©2013 GovMint.com.



Shop Proven Products

Bandsaw delivers accurate cutting at a just-right price

If you're looking for your first bandsaw, Grizzly's G0555LX provides a good place to start. Selling for less than half of what most deluxe 14" saws go for, this machine offers solid performance with a few frills you'd not expect at this price.

Powered by a 1-hp motor, the G0555LX resawed (ripped on edge) 6½"-wide hickory and red oak in my tests without any blade drift or deflection. When I fed the wood aggressively, though, it consistently tripped the 20-amp breaker in my shop. So, although it handles a sensible feed rate, don't expect it to be a resaw workhorse.

The G0555LX cuts curves cleanly and accurately, thanks to single-bearing blade guides and thrust bearings. Also worth noting: It has a rack-and-pinion blade guidepost for easy adjustment, a quick-release blade tensioner for fast blade changes, and comes with a rip fence. 🌲

—Tested by Bob Saunders



14" bandsaw (G0555LX)

Performance



Price

\$545

Grizzly Industrial
800-523-4777; grizzly.com



WOOD® ADVERTISER INDEX

AMERICAN FABRIC FILTER CO., INC.: Manufacturers of custom-made filter bags for the wood industry. p.81-82

AMERICAN FURNITURE DESIGN CO.: 150 of America's best furniture plans, comprehensive instruction guide. Catalog. p.81-82

AZTEC STEEL CORP.: Quality pre-engineered arch-style steel buildings at the lowest cost anywhere. p.81-82

BEREA HARDWOODS: Quality pen kits and other turning kits. p.11

BRIWAX: p.80

BYEGONE WORKSHOPS: p.81-82

COOK'S SAW MFG., L.L.C.: Portable sawmills, edgers, sharpeners, band blades... Free catalog. Video available. p.76

COUNTRY HOME PRODUCTS: pp.10,14, and 73

DETAILED PLAY SYSTEMS: Wooden swingsets and playground equipment for the backyard. Free catalog. p.81-82

DIGITAL WOOD CARVER: Bring a CNC router into your shop at an affordable price. p.81-82

EAGLE AMERICA: Largest selection of professional quality, American-made router bits + 100's of unique woodworking accessories. p.68

EHEAT, INC.: p.75

EPILOG: Wood engraving and cutting systems—Low price, high-quality laser systems. p.80

FORREST MFG. CO., INC.: Top quality blades and dados for an ultra smooth finish. p.76

FREUD FUSION SAW BLADES: p.17

FURNITURE MEDIC: Offering franchises to perform on-site furniture and wood repair. p.8

GRIZZLY INDUSTRIAL, INC.: Providing quality woodworking and metalworking machines and tools to American workshops and businesses since 1983. Inside front cover

GUHDO-GMAXX: Manufacturer of German-made, high-quality carbide-tipped saw blades and router bits. We offer a unique electrostatic coating. p.3

HARBOR FREIGHT TOOLS: p.64-65

HUT PRODUCTS: Woods, acrylics and supplies for pen and game call turning. p.81-82

INFINITY CUTTING TOOLS: Premium quality router bits/sets, shaper cutters, saw blades, planer/jointer knives. p.81-82

JET: Introducing the New 1221VS JET Lathe. Stand Behind Your Work. 350+ service centers nationwide, industry-leading warranties, expert technical service. p.7

KLOCKIT: The leading supplier of clock-making supplies for over 35 years. p.81-82

KREG TOOL COMPANY: From pocket screws to precision routing and beyond, Kreg provides woodworkers and DIYers with products that help simplify woodworking challenges. Inside back cover

LAGUNA TOOLS: Fine woodworking machines. Award-winning bandsaws, European quality machines with over 25 years of experience. p.23

LEE VALLEY TOOLS LTD.: Visit us online to view or to request our free woodworking tools catalog. p.41

LIGNOMAT USA, LTD.: Affordable, reliable, pin and pinless moisture meters for wood. Free catalog. p.81-82

MD HEARING: p.79

MLCS WOODWORKING: Router bits, router tables, variety of accessories. Best quality, huge selection, low prices, superior service. Free shipping. p.45

NORWOOD SAWMILLS: Portable sawmills, edgers, ATV skidders, hydraulic tractor-mounted skidding winches and wood splitters. p.81-82

OLD MASTERS: CRAFTSMAN-QUALITY STAINS AND FINISHES: Quality stains and finishes to protect and enhance wood's beauty and richness. p.12

ONEIDA AIR SYSTEMS, INC.: Free informative catalog contains dust collection systems and complete ductwork. pp.9,70

OSBORNE WOOD PRODUCTS, INC.: A free catalog of table legs, corbels, and island legs. p.74

PACKARD WOODWORKS: Free Catalog for WOODTURNERS! — Quality lathes, tools and supplies. p.81-82

PENN STATE INDUSTRIES: Award-winning dust collection. Collectors, cyclones, ductwork and more. p.15

PENN STATE INDUSTRIES: Create stunning, easy-to-make pens. Get everything you need to start. Plus, work healthier with PSI dust collectors. p.13

PHASE-A-MATIC, INC.: Convert 1-phase electric power into 3-phase; run 3-phase equipment anywhere. p.81-82

QUICKSCREWS INTERNATIONAL CORP.: Full line of screws made exclusively for the woodworking industry. Buy any selection online. p.80

RADARCARVE: Manufacturer of specialized wood carving duplicators. p.81-82

ROCKAUTO.COM: Check out www.RockAuto.com for all the parts your car or truck will ever need. p.21

ROCKLER WOODWORKING AND HARDWARE: One of the nation's premier suppliers of specialty hardware, tools, lumber and other high quality woodworking products. p.11

SAWSTOP: SawStop tablesaws stop the blade upon contact with skin. p.25

STANLEY-BOSTITCH SMARTPOINT: Back Cover

STAUER: pp.27,77

STEEBAR: For over 20 years supplying clock kits, pen making kits, and woodworking plans. p.81-82

SUPERMAX TOOLS: Exceptional drum, brush, and wide-belt sanders for the professional and enthusiast. p.8

TITEBOND: The widest variety of glues and adhesives for woodworkers of all skill levels. The industry standard for over 75 years. p.67

WAGNER METER: p.10

WILDWOOD DESIGNS SCROLLSAW PATTERNS: Up to 74" clocks, 300+ patterns, books, clock parts, saw blades, tools, wood! p.76

WOOD-MIZER PRODUCTS: Eight portable sawmills available starting with the LT10 at \$3995. p.81-82

WOODCRAFT SUPPLY, LLC: Quality tools, supplies and expert advice from Woodcraft can help take your woodworking to the next level. pp.14,19

WOODLAND POWER PRODUCTS: Cyclone Rake information. p.75

WOODMASTER TOOLS: Multi-duty planers that mold, sand & saw. p.81-82

WOODSTOCK INTERNATIONAL, INC.: Selling fine quality woodworking & metalworking machines through thousands of dealers since 1989. p.5

WOODWORKERS SOURCE: Hardwoods from around the world. p.68

ZOYSIA FARMS NURSERIES: Amazoy Zoysia grass saves you time, work and money. p.71

WOOD MAGAZINE ARTICLE ARCHIVE ON DVD: p.83

WOOD MAGAZINE WEEKEND WITH WOOD™: Become a better woodworker in one weekend. pp.12,69

WOOD MAGAZINE WOODWORKING PLANS: 1,300+ top-quality furniture, shop, and gift plans from the editors of WOOD® magazine. p.80

For more information about these advertisers, visit
woodmagazine.com/adindex

Chicago Doctor Invents Affordable Hearing Aid

Outperforms Many Higher Priced Hearing Aids

Reported by J. Page

CHICAGO: A local board-certified Ear, Nose, Throat (ENT) physician, Dr. S. Cherukuri, has just shaken up the hearing aid industry with the invention of a medical-grade, affordable hearing aid. **This revolutionary hearing aid is designed to help millions of people with hearing loss who cannot afford—or do not wish to pay—the much higher cost of traditional hearing aids.**

“Perhaps the best quality-to-price ratio in the hearing aid industry” – Dr. Babu, M.D. Board

Certified ENT Physician

Dr. Cherukuri knew that untreated hearing loss could lead to depression, social isolation, anxiety, and symptoms consistent with Alzheimer’s dementia. **He could not understand why the cost for hearing aids was so high when the prices on so many consumer electronics like TVs, DVD players, cell phones and digital cameras had fallen.**

Since Medicare and most private insurance do not cover the costs of hearing aids, which traditionally run between \$2000-\$6000 for a pair, many of the doctor’s patients could not afford the expense. Dr. Cherukuri’s goal was to find a reasonable solution that would help with the most common types of hearing loss at an affordable price, not unlike the **“one-size-fits-most” reading glasses** available at drug stores.

- **Designed By A Board Certified Ear, Nose and Throat (ENT) Doctor**
- **Doctor-Recommended, Audiologist-Tested**
- **★★★★★ Top rated hearing aid online—thousands of satisfied customers**
- **FDA-Registered**
- **Save Up To 90%**
- **Free Shipping Available**
- **Batteries Included! Comes Ready To Use**
- **100% Money Back Guarantee**



He evaluated numerous hearing devices and sound amplifiers, including those seen on television. Without fail, almost all of these were found to amplify bass/low frequencies (below 1000 Hz) and not useful in amplifying the frequencies related to the human voice.

Inspiration from a surprising source

The doctor’s inspiration to defeat the powers-that-be that kept inexpensive hearing aids out of the hands of the public actually came from a new cell phone he had just purchased. **“I felt that if someone could devise an affordable device like an iPhone® for about \$200 that could do all sorts of things, I could create a hearing aid at a similar price.”**

Affordable Hearing Aid With Superb Performance

The high cost of hearing aids is a result of layers of middlemen and expensive unnecessary features. Dr. Cherukuri concluded that it would be possible to develop a medical grade hearing aid without sacrificing the quality of components. The result is the MDHearingAid PRO®, starting well under \$200. **It has been declared to be the best low-cost hearing aid that amplifies the range of sounds associated with the human voice without overly amplifying background noise.**

Tested By Leading Doctors and Audiologists

The MDHearingAid PRO® has been rigorously tested by leading ENT physicians and audiologists who have unanimously agreed that the **sound quality and output in many cases exceeds more expensive hearing aids.**

DOCTORS AND PATIENTS AGREE: “BEST QUALITY SOUND” “LOWEST AFFORDABLE PRICE”

*“I have been wearing hearing aids for over 25 years and these are the best behind-the-ear aids I have tried. **Their sound quality rivals that of my \$3,000 custom pair of Phonak Xtra digital ITE**”* —Gerald Levy

*“I have a \$2,000 Resound Live hearing aid in my left ear and the MDHearingAid PRO® in the right ear. **I am not able to notice a significant difference in sound quality between the two hearing aids.**”* —Dr. May, ENT physician

*“We ordered two hearing aids for my mother on Sunday, and the following Wednesday they were in our mailbox! Unbelievable! Now for the best part—they work so great, my mother says she hasn’t heard so good for many years, even with her \$2,000 digital! **It was so great to see the joy on her face. She is 90 years young again.**”*
—Al Peterson

For the Lowest Price Call Today

1-800-873-0680

Phone Lines Open 24 Hours EVERY DAY

www.MDHearingAid.com/FL48

**Use Offer Code FL48 to get
FREE Batteries for a Full Year!**

FREE Shipping Available

MDHearingAidPRO® 
THE DOCTOR’S CHOICE FOR AFFORDABLE HEARING AIDS



**45 DAY
RISK FREE
TRIAL**



Proudly assembled in the USA

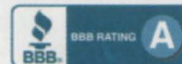

Save 33% on

BASIC-BUILT™

GREAT PROJECTS MADE SIMPLE.

Project Plans

These projects require no expensive tools and only home-center materials!



See them all at woodmagazine.com/basic33

Enter coupon code BASIC33 at checkout.
Sale ends May 1, 2013.

World-Famous Waxes & Fine Wood Care Products



CRAFTSMEN'S CHOICE
SINCE 1860
MADE IN ENGLAND



MAKING WOOD
BETTER THAN
NATURAL!™



Not available in a
"Big Box" Lumber Store

Available ONLY through
Fine Woodworking Distributors
and Exclusive Retailers

BRIWAX Available in Clear & 9 Great Colors

WWW.BRIWAX.COM

Or Call: 1-800-5BRIWAX
(1-800-527-4929)

Best New
Product Sellers
for 2012

Cut it. Mark it. Sell it.

THE FINISHING TOUCH STARTS HERE.

MADE IN USA

Systems starting at \$7,995



To request a brochure, DVD, and laser engraved and cut samples visit
www.epiloglaser.com/bhg or call 888-437-4564 today!

QUICK SCREWS

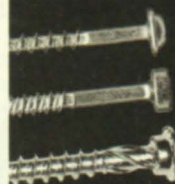

- Driver Bits
- Pocket Hole Screws
- Funnel Head Screws
- & More!

Widest Line of
**WOODWORKING
SCREWS**
In America!

OVER 1000 Woodworking Fastener Products
Available in our New Online Store!

www.quickscrews.com

TURN
TO
PACKARD
FOR
QUALITY
TURNING TOOLS
AND
SUPPLIES



Packard
WOODWORKS
INC.

1-800-683-8876
PACKARDWOODWORKS.COM

DETAILED
Play Systems

Backyard
Playground
Equipment

FREE CATALOG!

Just Add
Lumber!

FREE SMILES!



Do it Yourself and Save!
www.detailedplay.com
1-800-398-7565

**Like Having a
Lumberyard Right
in Your
Shop!**



60-Day
FREE TRIAL

**4-WAY MONEY
MAKER!**

Now, turn a \$5 board into \$75 worth of high-dollar molding in less than one minute! Over 600 patterns plus curved molding, tongue & groove, picture frame stock, custom work. Quickly CONVERTS to molder, planer, sander, saw. 12", 18" & 25" models, 60-Day Free Trial, 5-Year Warranty. Made in USA!

FREE DVD & BUSINESS STARTER KIT!

1. MOLDER
2. PLANER
3. DRUM SANDER
4. GANG RIPSAW

www.woodmastertools.com
Toll Free 1-800-821-6651 Ext. P368
Woodmaster Tools, Inc. 1431 N. Topping Ave., Kansas City, MO 64120

MADE IN THE USA



Easy to Build
Easy to Own!

GARAGES • WORKSHOPS



NO MAINTENANCE



AMERICAN STEELSPAN

800-891-6733
www.steelspan.com ext 018

**MAKE LUMBER
MAKE MONEY**

PORTABLE SAWMILLS
from just \$3997

IN STOCK

FREE CATALOG & DVD
Toll-Free: 800-661-7746 Ext. 392
www.norwoodsawmills.com/392

NORWOOD
WOODWORKS
INC.

Award Winning Tools & Accessories

INFINITY

Exclusive Carbide & HSS Knives

DEWALT DW 734 & 735

- ✓ Lasts Longer
- ✓ Thicker
- ✓ Stronger

From \$79.90



5-STAR RATING
WOOD
MAGAZINE
2011

infinitytools.com | 877-USA-BITS

**DIGITAL
WOOD-CARVER**

AFFORDABLE
CNC WOOD
ROUTER



DIGITALWOODCARVER.COM

WWW.PENMAKINGSUPPLIES.COM

Pen Kits, Pen Blanks,
Finishing Products,
Lathes, & More!



**ORDER
TOLL FREE
1-800-653-1930**

Moisture Meters

Avoid
Shrinking
Warping
Cracking
Cupping
Delamination

Don't waste time and money on wet wood, use a moisture meter

With a Lignomat meter you buy Quality and Accuracy Professional Service and a 2-Year Warranty!

Lignomat offers pin and pinless meters

**Lignomat: 800-227-2105 www.lignomat.com
www.wood-moisture.com Email:sales@lignomat.com**



KLOCKIT

Helping You Buy, Build and Restore Time & Weather Products For Over 40 Years

**Unique Kits and Plans,
Popular Weather Products
Available Now!**



Request Your
**Free
Catalog!**

Dept Code: WD413

Visit www.klockit.com

1-800-556-2548

Follow Klockit on:

Scan with
your Smart
Phone



**Can Your Old Dust Collector
Work Better Than A New One?**



Yes, With Optimized Filters From...



- Optimum Performance
- Low Maintenance
- Custom Designs
- Cleaner Air
- Longer Life
- Economical
- Best Size & Fit
- Proudly Made In USA

6 Mil Poly Bags
In Stock!

*We Design & Fabricate Custom Filter
Bags That REALLY WORK!*

American Fabric Filter Co.

(800) 367-3591 americanfabricfilter.com



HUT
Products

**ENJOY YOUR
CREATIVITY!**

**With Our
Comprehensive
Inventory of Game
Call & Pen Turning
Supplies**



**EASY ONLINE
ORDERING**

hutproducts.com
1-800-547-5461

**Turn to
Quality**

PHASE-A-MATIC PHASE CONVERTERS



CONVERTS 1-PHASE to 3-PHASE POWER!

1-800-962-6976

www.phase-a-matic.com

WWW.RADARCARVE.NET Wood Carving Duplicators

- Furniture
- Gunstocks
- Millwork
- Decoys
- Musical Instruments

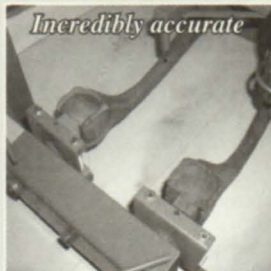

Thousands of Uses 505-948-0571

Projects and Plans



Wheelbarrow

Kit to build includes 15" iron wheel that really works, axle and step-by-step plans. Finished project measures 66" L x 24" W x 26" H. \$47.90 P.P.D.

ByeGone Workshop
888-279-3941 8-5 M-F EST
www.bye-gone.com

BOW ARM MORRIS CHAIR

This award winning chair has been featured in Magazines and has won woodworking contests across the country. Our assembly directions have over 25 step by step photographs to assure a great project.



FREE CATALOG AMERICAN FURNITURE DESIGN
P.O. BOX 300100 ESCONDIDO, CA 92030
BOW ARM MORRIS CHAIR \$19.95 + \$5.00 S/H
Phone 760 743-6923
www.americanfurnituredesign.com

DREAM PROJECT DREAM MACHINE

Saw your own lumber,
12 sawmill models available
starting at \$3,950*

Wood-Mizer

800.553.0182 SawBoards.com



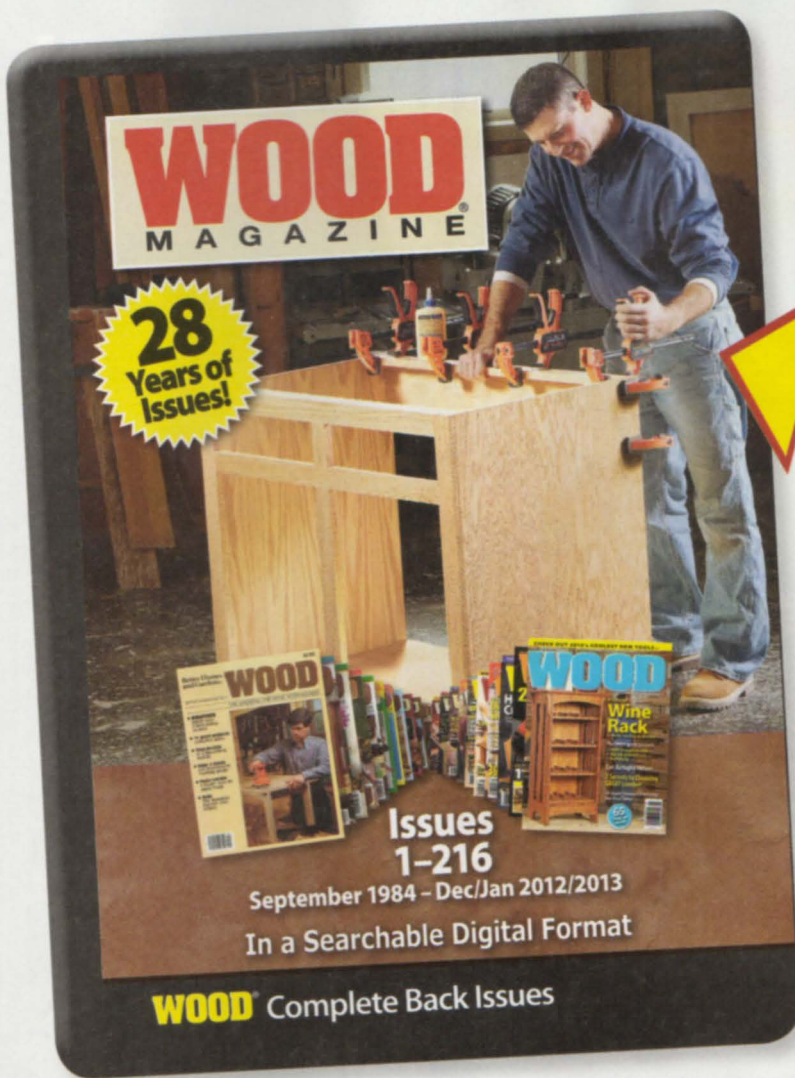

Buy this,

**get this
FREE!**

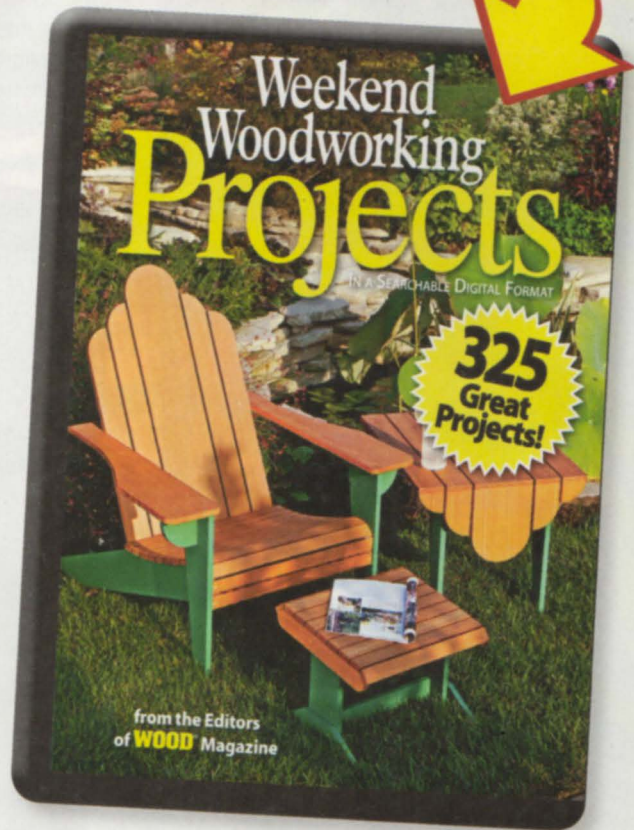

**Both discs
for only \$149⁹⁵**

**Save
\$50!**

Order online at woodmagazine.com/ultimatedeal or by phone at **888-636-4478**

Hurry, sale ends May 1st, 2013!

AD#WD0513

What's Ahead

A glimpse inside the July issue (on sale May 7)

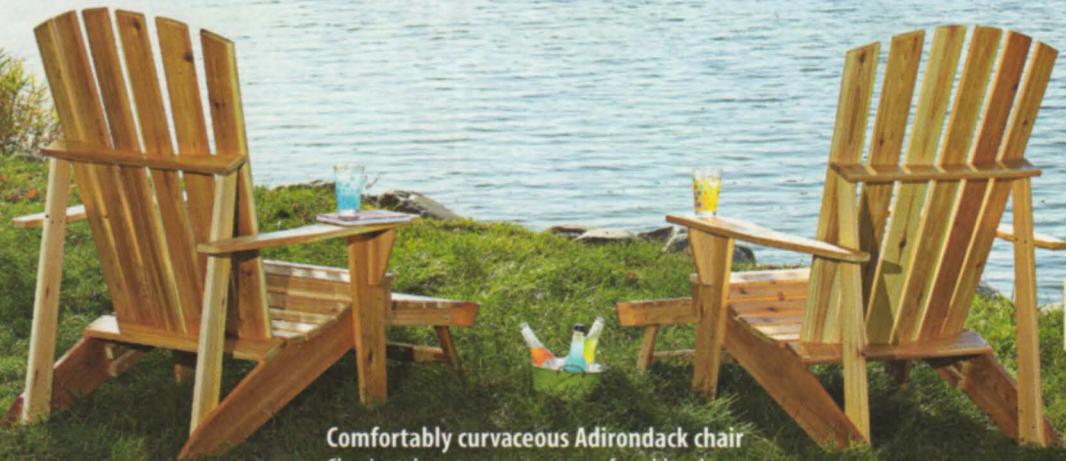

Comfortably curvaceous Adirondack chair
Classic style gets even more comfortable when you kick your feet up on this chair's pull-out footrest.



Matching dresser and nightstand
Similar construction simplifies building both of these pieces that complement the traditional bed on page 34 of this issue.

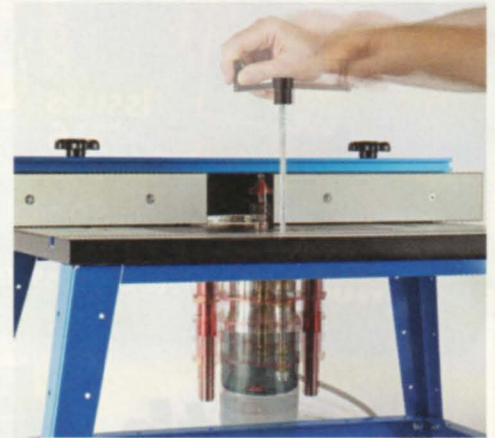

Four router-lifting strategies
From low-dough to super-deluxe, we compare different ways to accurately set bit heights in a router table.



Raised-panel... boxes!
Get more from these premium-priced bits by using them to create beautiful boxes.



Construction-grade scraper
This down-size digger moves, pivots, and hauls a load just like the real thing.

Kreg Universal Bench

NEW!

Create a custom-sized workbench, outfeed table, tool stand, or assembly table to fit your shop, your projects, & your needs!



Bench Top

can be built from your choice of material and easily attached

High-Quality Hardware
for simple, solid assembly

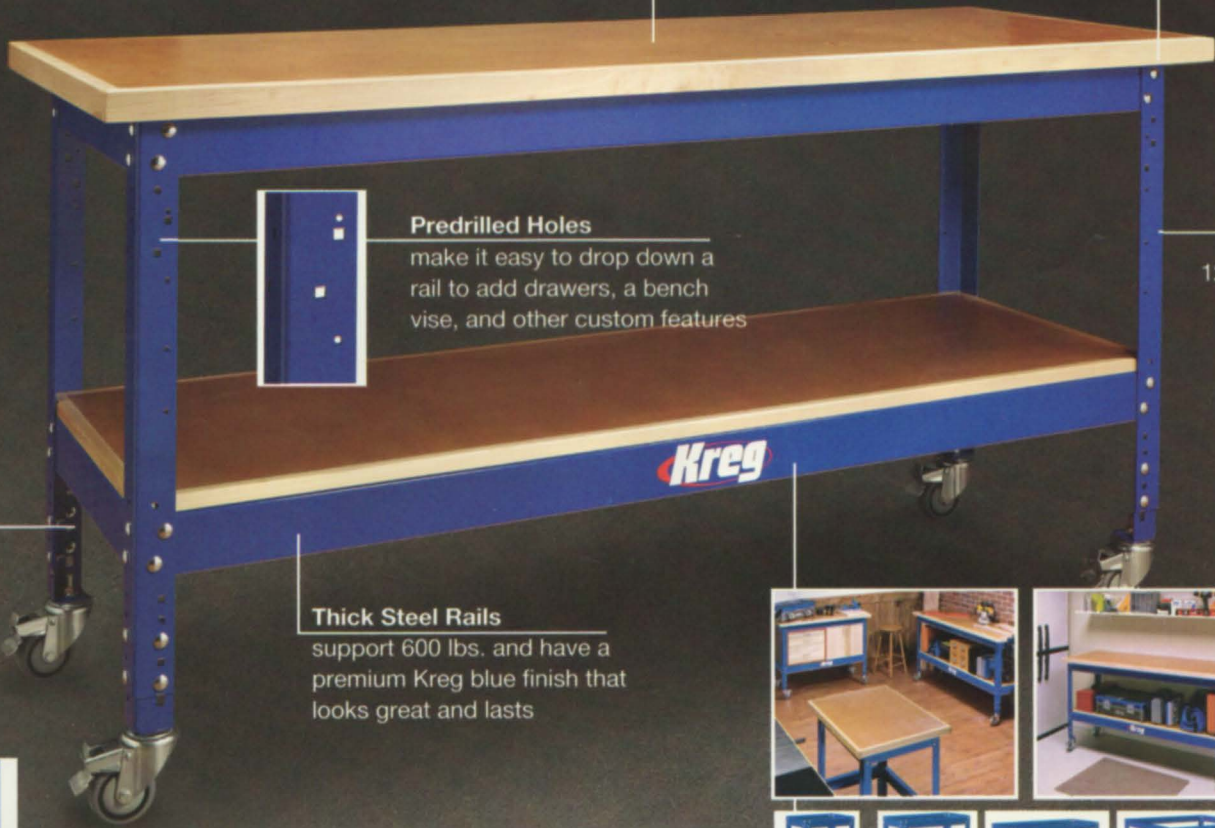

Predrilled Holes

make it easy to drop down a rail to add drawers, a bench vise, and other custom features

Sturdy Legs

made from 12-gauge steel are available in two adjustable heights

Thick Steel Rails

support 600 lbs. and have a premium Kreg blue finish that looks great and lasts



Adjustable Leg Levelers & Feet

adjust 6" so you can match the height of your table saw or another bench, and accommodate uneven floors



5 Different Rail Lengths

make it easy to create a custom bench that fits your garage or shop

Any Space, Any Task, Any Size

We make it easy! Just choose your rails to determine the size and select legs to set the height, and you can create a customized bench in one of 15 possible sizes and 2 adjustable heights to fit your space and your projects!



Watch the video at www.kregtool.com



www.kregtool.com | 800.447.8638

DETAILS MATTER

THE RIGHT BALANCE OF FEATURES
FOR A FINE FINISH



BN200C



NS150C

It's all about the details. In your finishing touches and our finishing tools. The Porter Cable BN200C 2" Brad Nailer has been updated from its previous version to be more compact, lightweight and easy to use. All at a lower price. Touting an oil-free design, rear exhaust, tool-free depth of drive, tool-free jam release and more, it's the right balance of features to add your finishing touches. The same great features also available in the NS150C Finish Stapler.

To learn more about Porter Cable Finish Nailers, visit portercable.com or stop by a retailer near you.

www.PorterCable.com

© 2013 Porter Cable, Inc.

PORTER  CABLE