

The Knitter

Create • Knit • Enjoy

Masterclass
Discover three useful
circular cast-ons



Jennie
Atkinson

Feminine
wrap cardigan

Emma
Vining

Elegant cabled
jacket

Jeanette
Sloan

Lightweight stole

Spring Colour

Cast on pretty stitch patterns and
soft shapes to brighten your day!

Plus...
SECRET STITCHES
Stories of knitting
in Victorian prisons





BRAND NEW
A stunning arrangement of
6 prints & 7 solids shades



FOR MORE INFORMATION AND YOUR NEAREST STOCKIST VISIT



WWW.WYSPINNERS.COM

TEL: (0)1535 664500 · EML: SALES@WYSPINNERS.COM





The Knitter

Issue 122

Indulge your love of knitting with beautiful stitch patterns and gorgeous yarns! We've filled this issue with ideas for spring, including Emma Vining's neat cardigan on **p24**, the perfect baby knit for a new arrival on **p37**, and an elegant wrap from Jeanette Sloan on **p49**. Plus, discover the best new yarns for your spring projects on **p32**.

Create



Knit



Enjoy

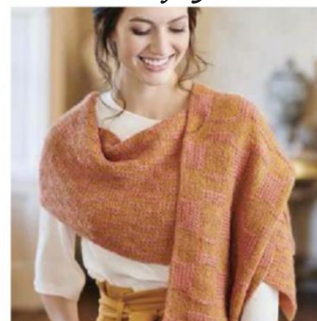

The Knitter

Create • Knit • Enjoy



On the cover | 8



24



37



65

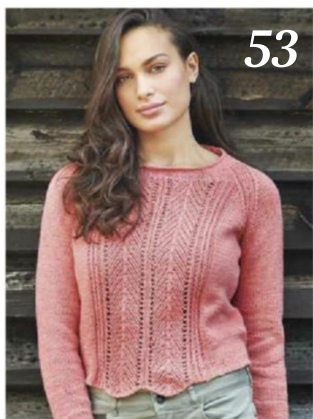

53



74

Patterns

8 **PENELOPE HEMINGWAY**
Hetty

Large, square hap shawl with striped lace borders

24 **EMMA VINING**
Shimmer

Neat open cardigan featuring an unusual cable pattern

37 **SARAH HATTON**
Pippa

Cardigan for baby girls, decorated with a peplum

44 **PAT MENCHINI**
Bellina

Colourful jumper using an array of lace stitch patterns

49 **JEANETTE SLOAN**
Riley Stripe

Elegant slip-stitch wrap

53 **SARAH HATTON**
Amure

Cropped jumper with a lacy panel in a cashmere blend

58 **JENNIE ATKINSON**
Cicely

Wrap-fronted cardigan with embroidered detailing

65 **CAROLINE BIRKETT**
Moss Rose

Long Fair Isle armwarmers

71 **BERGERE DE FRANCE**
Camille and Loïc

Women's aran jumper and a sporty sweater for men

PLUS **DARIO TUBIANA**
Monte Viso

Colour-block jumper with cables and mohair stripes

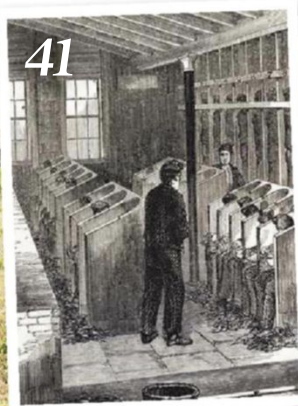
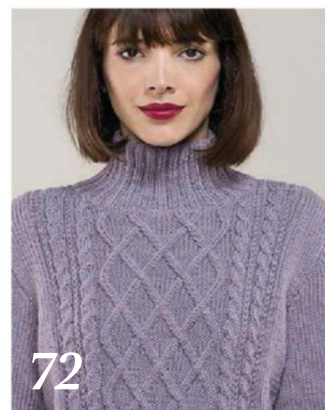

Good reads

14 THE KNITTER LOVES

News and diary dates from the knitting world

30 BEST OF THE BEST

The winners of the British Craft Awards revealed

41 PURLS & PUNISHMENT

Stories of knitting in 19th century prisons

82 KARIE WESTERMANN

We chat with the popular Danish-Scottish designer

Expertise

32 YARN REVIEWS

The latest yarn releases, tested and rated

34 BOOK REVIEWS

Our favourite knitting books

68 MASTERCLASS

Step-by-step guide to three circular cast-on methods

81 INFORMATION

Essential abbreviations, pattern corrections and stockist details

Plus...

22 SUBSCRIBE UK

Get 13 issues for the price of 9 - save £1.84 every issue!

78 SUBSCRIBE OVERSEAS

International subscribers save up to 70%

79 NEXT MONTH

A sneak peek at what's inside Issue 123

80 BACK ISSUES

How to access the patterns in *The Knitter's* archives

Subscribe digitally at www.theyarnloop.com/magazine/the-knitter/digital

Don't miss an issue!

Make sure you receive every issue of *The Knitter* – delivered direct to your door.

TURN TO PAGE 22 FOR GREAT SUBSCRIPTION OFFERS

Lace & colour

Lightweight layers for your spring wardrobe



Welcome the spring!

We're excited to bring you our latest pattern collection, which is filled with pretty lace stitches, elegant shapes and cheerful colour - perfect for the brighter spring days ahead!

Decorate your shoulders with Penelope Hemingway's hap shawl or Jeanette Sloan's smart slip-stitch wrap, or choose one of our feminine cardigans, such as Jennie Atkinson's embroidered design. We also have the sweetest little baby cardigan from Sarah Hatton, and a chic aran sweater.

HAPPY KNITTING!

from *The Knitter* team

Our featured designers



Jennie Atkinson

Jennie has a worldwide fanbase, thanks to her feminine designs which have appeared in *Vogue Knitting*, *The Knitter* and Rowan's magazines. Her latest creation for us is a comfortable yet pretty wrap-around cardigan, decorated with embroidery. Find the pattern on **page 58**.



Jeanette Sloan

Always creative and inspiring, Jeanette has been designing handknit patterns for many years, with her work appearing in all the major UK knitting magazines. She loves to work with colour and texture, and is fascinated by modern art. You can find her Bridget-Riley inspired wrap on **page 49**.



Emma Vining

Emma is known for her exquisite stitch patterns and fabric textures, many of which have been influenced by artefacts found in London's museums. This month, she has been creative with cables, designing a neat and elegant cardigan for us. Turn to **page 24** for her pattern.

Immediate Media Company Bristol Limited (company number 05715415) is registered in England and Wales. The registered office of Immediate Media Company Bristol Limited is at Vineyard House, 44 Brook Green, London W6 7BT. All information contained in this magazine is for information only and is, as far as we are aware, correct at the time of going to press. Immediate Media Company Bristol Limited cannot accept any responsibility for errors or inaccuracies in such information. Readers are advised to contact manufacturers and retailers directly with regard to the price of products/services referred to in this magazine. If you submit unsolicited material to us, you automatically grant Immediate Media Company Bristol Limited a licence to publish your submission in whole or in part in all editions of the magazine, including licensed editions worldwide and in any physical or digital format throughout the world. Any material you submit is sent at your risk. Although every care is taken, neither Immediate Media Company Bristol Limited nor its employees agents or subcontractors shall be liable for loss or damage.

We abide by IPSO's rules and regulations. To give feedback about our magazines, please visit immediate.co.uk, email editorialcomplaints@immediate.co.uk or write to Debora Bradley, The Knitter, Immediate Media Co. Ltd, Tower House, Fairfax Street, Bristol BS1 3BN, UK

Printed in the UK by William Gibbons. Distributed by Frontline

The Knitter

EDITORIAL

Commissioning Editor Kirstie McLeod
Operations Editor Helen Spedding
Art Editors Sarah Clark, Jude Curle
Technical Editor Faye Perriam-Reed
Technical Assistant Jen Bartlett
Editorial Assistant Louise Smith
Editor in Chief Debora Bradley
Group Senior Editor Julie Taylor
Photography Philip Sowels, Jesse Wild, Dave Caudery

CONTRIBUTORS

Jennie Atkinson, Caroline Birkett, Charlotte Foster-Brown, Kate Evans, Thelma German, Sarah Hatton, Penelope Hemingway, Ashley Knowlton, Pat Menchini, Jeanette Sloan, Dario Tubiana, Emma Vining

ADVERTISING

0117 300 8206

Senior Advertising Manager Penny Stokes
Account Manager Rachael Hawkins
Sales Executive Ali Johnson

MARKETING & SUBSCRIPTIONS
Subscriptions Marketing Executive Kate Jones

CIRCULATION

Newstrade Marketing Manager Janine Smith

PRODUCTION

Production Coordinator Sarah Greenhalgh
Production Manager Louisa Molter/Rose Griffiths
Production Director Sarah Powell

LICENSING

Director of Licensing & Syndication Tim Hudson

PUBLISHING

Publishing Director Kerry Lawrence
Managing Director, Bristol Andy Marshall
Chief Executive Officer Tom Bureau

SUBSCRIPTIONS

Phone: 03330 162 151

Email: theknitter@buysubscriptions.com

Subscribe online:

buysubscriptions.com/craft

GET IN TOUCH

Immediate Media Company Ltd,
Tower House, Fairfax Street,
Bristol BS1 3BN, United Kingdom
Phone: 0117 927 9009

Email: theknitter@immediate.co.uk

Next issue on sale
Thursday 12 April 2018

IMMEDIATE MEDIA CO



When you have finished with this magazine please recycle it.



ROWAN

The Art Of Knitting



www.knitrowan.com



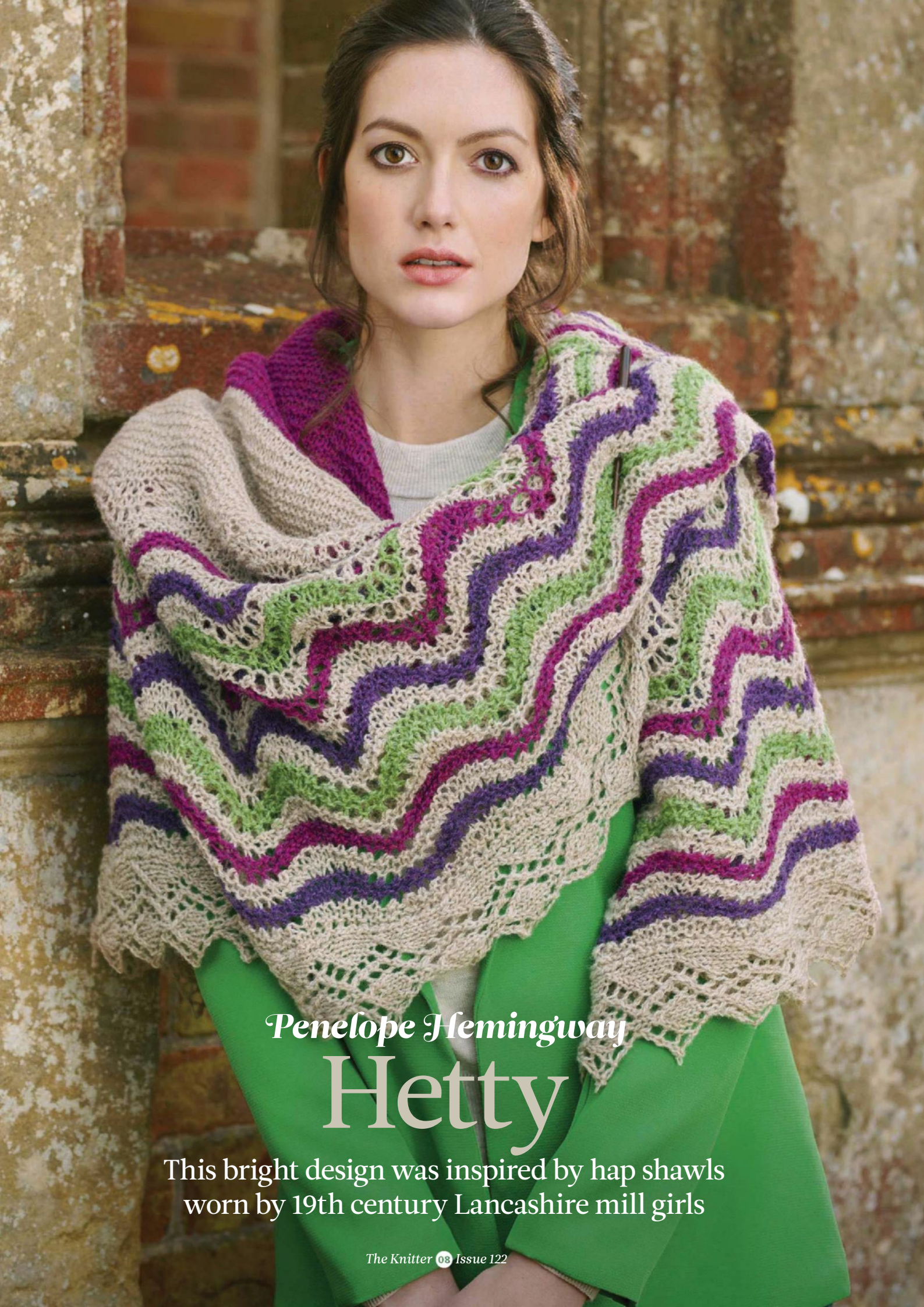

Penelope Hemingway

Hetty

This bright design was inspired by hap shawls worn by 19th century Lancashire mill girls

Hetty

Colourful border is knitted on to the central square





Penelope Hemingway
Hetty

DESIGNED BY knitting historian Penelope Hemingway, this hap shawl was inspired by the shawls worn by Lancashire mill girls of the 19th century. The finished project is large, so it is guaranteed to keep you cosy on chilly spring days! The design features a central square, worked here in a bright colour, and edged with feather-and-fan lace in colourful stripes. Penelope has knitted her shawl in JC Rennie's Unique Shetland, a pure wool from Shetland that comes in a wide range of colours.

SHAWL
CENTRE SQUARE

Note: This section is knitted flat, on two needles or circular needles, like a traditional Lancashire square, then seamed before you knit on the border and the edging.

Using 4mm circular needles and yarn A, cast on 341 sts using a provisional cast-on method. Place mrk to denote beg of rnd.

Row 1: Knit.

Row 2: Knit.

Row 3: K2tog, (K82, K3tog, pm) 3 times, K82, K2tog. 333 sts.

Row 4 and all alternate rows: Knit.

Row 5: K2tog, (K80, K3tog, slm) 3 times, K80, K2tog. 325 sts.

Row 7: K2tog, (K78, K3tog, slm) 3 times, K78, K2tog. 317 sts.

Continue in this way, decreasing 8 sts every alt row, until the following row has just been worked:

Row 35: K2tog, (K48, K3tog, slm) 3 times, K48, K2tog. 205 sts.

Change to yarn B.

SIZE

140cm x 140cm (55in x 55in)

YARN

JC Rennie Unique Shetland 4 Ply (4ply weight; 100% wool; 215m/236yds per 50g ball)

A Oat Milk (961); 3 x 50g balls

B Petunia (344); 2 x 50g balls

C Iris (1434); 1 x 50g ball

D Crabapple (405); 1 x 50g ball

YARN STOCKISTS

JC Rennie 01771 622422

www.knitrennie.com

Continue as set until 13 sts remain, ending on a decrease row.

Row 84: K13.

Row 85: (K3tog) 3 times, K4tog. 4 sts.

Row 86: K4.

Row 87: Cast off loosely, leaving a long tail.

Using this yarn tail, neatly graft or sew together the square's diagonal seam, so you now have a square.

BORDER

Begin knitting the hap in the round as follows:

Using 4mm circular needles and yarn A, pick up and knit 85 sts per side around the centre square. 340 sts.

Set-up round: *K1; placing a locking marker in this stitch, M1, slm, (K8, M1) 10 times, K4; rep from * 3 more times. 384 sts: 95 sts per side, and 1 st for each corner.

BEGIN CHART A

Begin working Chart A on sts between markers, knitting the marked stitch on every round and moving the marker up as you go.

Rounds 1-10: Work in yarn A.

Rounds 11-14: Work in yarn B.

Rounds 15-18: Work in yarn A.

Rounds 19-22: Work in yarn C.

Rounds 23-26: Work in yarn A

Rounds 27-30: Work in yarn D.

Rounds 31-34: Work in yarn A.

Rounds 35-36: Work in yarn B. 528 sts: 131 sts per side and 1 st at each corner.

Work Chart A once more as follows:

NEEDLES & ACCESSORIES

4mm (UK 8/US 6) circular needles, 100cm long

1 pair 4mm (UK 8/US 6) knitting needles, for edging

1 stitch marker

4 locking stitch markers

TENSION

14 sts and 28 rows to 10cm over garter st on 4mm needles

For general abbreviations, see p81

Rounds 1-2: Work in yarn B.

Rounds 3-6: Work in yarn A.

Rounds 7-10: Work in yarn C.

Rounds 11-14: Work in yarn A.

Rounds 15-18: Work in yarn D.

Rounds 19-22: Work in yarn A.

Rounds 23-26: Work in yarn B.

Rounds 27-30: Work in yarn A.

Rounds 31-34: Work in yarn C.

Rounds 35-36: Work in yarn A.

672 sts: 167 sts per side and 1 st at each corner.

Removing markers as you go, cont as folls:

Next rnd (Dec): *K2tog, K5, (K2tog, K4), (K2tog, K5) 21 times, (K2tog, K4), K2; rep from * 3 more times.

576 sts: 144 sts for each side.

When complete, do not cast off. Leave all stitches live. You are going to cast off the border by knitting it together with the edge, every other row.

EDGING

Using 4mm needles and yarn A, and a provisional cast-on method, cast on 9 sts loosely.

Work Chart B, working the last st of every WS row of the edging together with the live stitch from the shawl.

Rep rows 1-18 of Chart B until all the shawl sts have been worked.

Graft cast-on and cast-off ends of edging together.

FINISHING

Soak gently and block shawl to size by pinning out on a firm surface, over towels or blocking mats. Carefully place one pin at the apex of each 'wave' of the edging. Dry away from direct heat. Weave in ends. ➔

CHARTS

Chart A

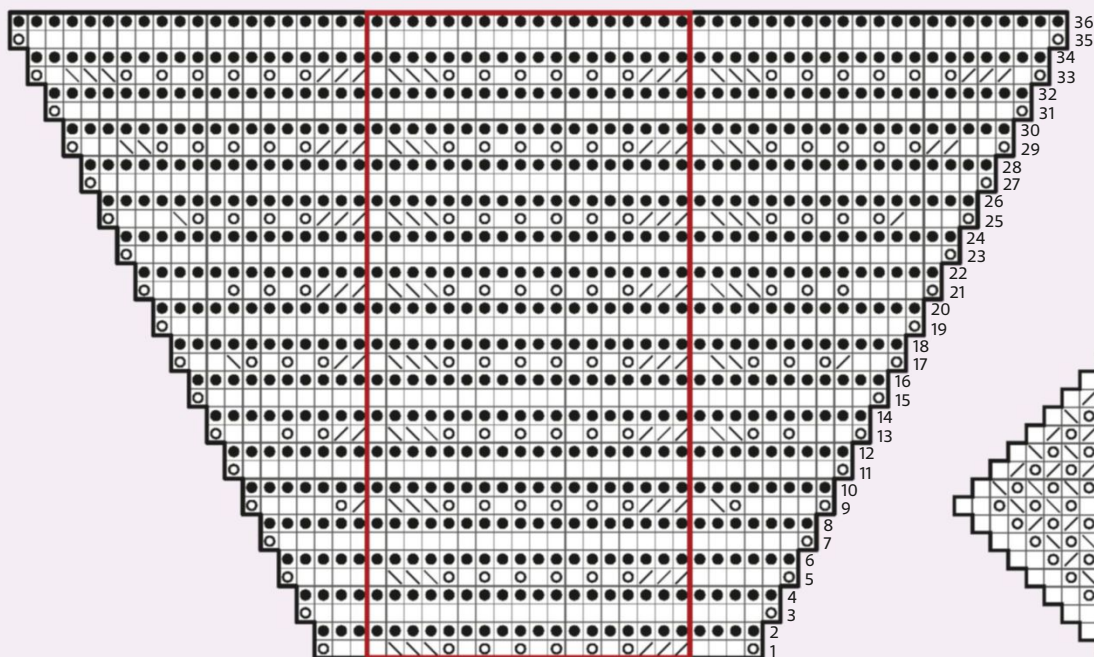
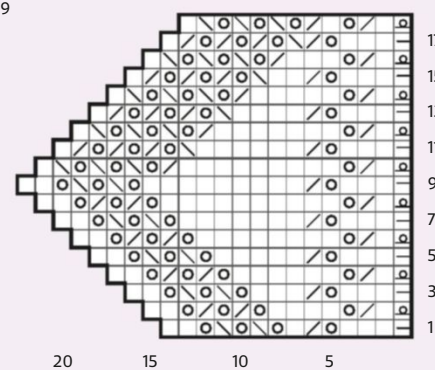

Chart B



KEY

- | | |
|--------------------------|------------------|
| K on RS; P on WS | P on RS; K on WS |
| K2tog on RS; P2tog on WS | Yo |
| SSK on RS; SSP on WS | Slip 1 purlwise |
| P2tog with st from shawl | Repeat |

BLOCKING DIAGRAM

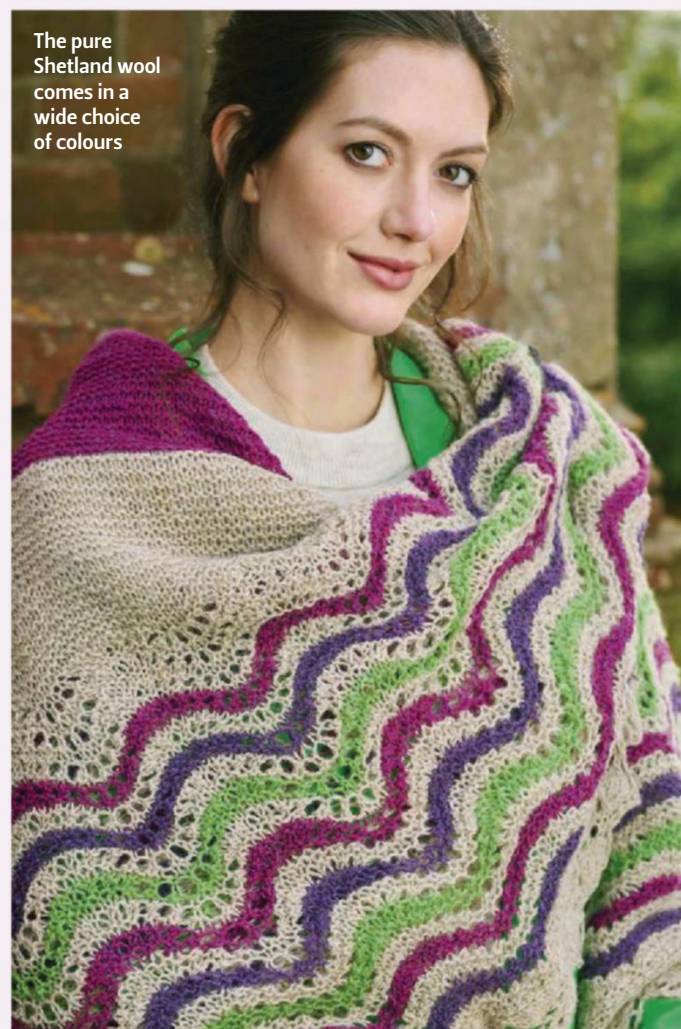

The pure Shetland wool comes in a wide choice of colours



The large square shawl feels light yet warm

Knitting tales

Penelope Hemingway explains the history behind her 'Hetty' shawl

This is not a traditional hap structure, but was inspired by the Lancashire cotton and woollen mill girls and women of the 19th century, so needs a small explanation.

I wanted to make a workaday shawl (a 'hap'), and was inspired by the practical, warm-looking, brightly coloured shawls of Lancashire mill workers of the 19th century. But these shawls were woven, not knitted. So I was looking for a way to knit a warm, functional shawl for everyday use, with the bold, geometric design of the woven shawls. And whilst I like the Scottish haps, I wanted to give myself a bit of a challenge with the shawl's structure.

Then I remembered: years ago, I found a pattern for knitting a perfect square, which intrigued me. It was taught to spinner and knitter Anne Campbell, in the 1960s, by her mother-in-law, who *"was told it by an old lady at the cotton mill in Lancashire where she worked as a girl doing cotton reeling. She said that when the thread broke or was knotted and tangled, they were allowed to bring home the pieces of cotton. These she unraveled and knitted or crocheted into blankets or tablecloths..."*

[SPIN OFF' MAGAZINE, WINTER 1993, p.88]

The pattern for the Lancashire square was intended to use up small scraps for patchwork, but because it gives a near-perfect square, I wondered whether I could adapt this traditional Lancashire recipe for a square by enlarging it for the centre of a hap. I made a number of squares, figuring out a sort of formula, so I could change the number of stitches cast on; I then tried to make increasingly larger squares, to see if my algorithm still worked.

The beauty of using a Lancashire square as the basis for a shawl is that the large central pattern is worked from the outside, inwards - which means you are constantly decreasing, rather than increasing. It seems to make the knitting go faster! The central section is knitted flat, then the seam is sewn up to form the square.

The border and edging are then knitted on from the live cast-on stitches around the centre square, as in the later 19th century 'English style' haps. Enjoy. ☺
www.theknittinggenie.com

LONDON
LOOP

Gorgeous knitting, crochet & embroidery supplies



LOOPKNITTING.COM

15 CAMDEN PASSAGE, ISLINGTON, LONDON, ENGLAND

The Knitter loves...

...ideas, websites, patterns, events, inspiration and more!

PRESENTING PIP

Baa Ram Ewe has launched its fifth yarn range, called Pip Colourwork - a pure wool created with stranded colourwork in mind.

The 4ply yarn comes in 25g balls, with 116m per ball and costing £3.20 each. It has been launched with 15 shades from Baa Ram Ewe's signature palette, including Lotherton teal, Wesley Bob red, and Viking orange.

To show off the new yarn, Baa Ram Ewe invited Isabell Kraemer to recreate some of her most popular sweater designs using Pip Colourwork. The resulting collection is packed with modern, wearable styles, such as the 'Bubbly' colourwork yoked sweater, and the relaxed 'Almost There' raglan jumper. The patterns can be downloaded from Ravelry at <http://bit.ly/isabellkraemer>.

www.baaramewe.co.uk 0113 278 1788



Isabell Kraemer's 'Bubbly' and 'Marsa Alam' have been reworked using Pip Colourwork



Bold colour New shades of *Stolen Stitches*
New yarn include *Cafe Flamingo*, *Figment* and *Late Night Blues* www.fyberspates.com/retailers or www.stolenstitches.com



AVANT GARDE

Danish designer Vithard Villumsen has been exploring the possibilities of knitting in his new book, *Texperimenture*. His playful approach has resulted in seven fascinating projects created in unconventional ways - using triangles or pipe shapes as the starting points of a sweater, for example. The unisex designs include a brioche pullover called 'Striber', and the versatile 'Ponchawl', which can be worn as a shawl, scarf or poncho.

Available from www.vithard.dk

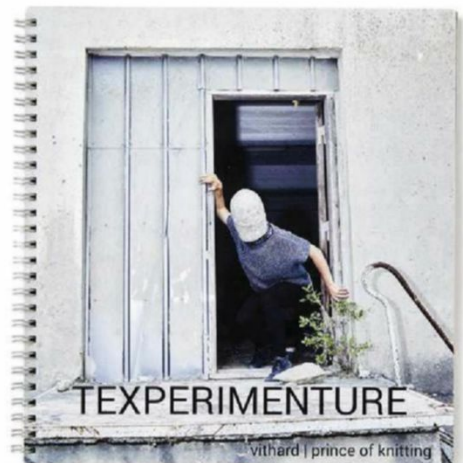

Find attractive knitting gifts at the **Daughter of a Shepherd** shop, including Woollenflower tweed project pouches, 'Sheepish' notebooks illustrated by Jill Draper, and adorable hand-stitched Hebridean sheep decorations. www.daughterofashepherd.com



SOFT &
PRETTY
LAYERS



Magazine 63

by Rowan

Filled with soft shapes, airy stitch textures and delicate colour patterns, Rowan's new magazine for spring-summer is a real treat! It has 38 designs for women using seasonal yarns such as Summerlite, Creative Linen, Handknit Cotton and Softyak.

A number of projects feature pretty, pictorial colourwork inspired by pottery makers such as Wedgwood, Spode and Delft. 'Porcelain', for example, is a draping kimono with intarsia motifs, created by Kaffe Fassett.

Intriguing lace textures add interest to a range of summery layers, including cardigans, lightweight jumpers and tops, and the 'Kayla' wrap-fronted waistcoat by Lisa Richardson.

More vibrant, tropical colours appear on a shawl-collar coat, a textured tank top, and a chevron-striped cardigan. There's also a wide choice of classic wardrobe essentials, all sized to fit up to 50in busts or larger.

£12.50. For stockist details, call **01484 950630** or visit **www.knitrowan.com**



NEW BOOKS

Our pick of the best pattern collections and e-books

MINI KNITTED FARMYARD Sachiyo Ishii



Japanese designer Sachiyo Ishii creates the most adorable miniature creatures, and her latest book of patterns goes down on the farm. There are more than 40 mini knits here, and children will love the tiny cows and pigs, sheep and alpacas - if you're feeling adventurous, why not create an entire farm for them, complete with farmers and shepherds, a thatched cottage, a duck pond, scarecrows and a vegetable patch? **£9.99, Search Press**

VOGUE KNITTING: THE ULTIMATE KNITTING BOOK Vogue Knitting



This essential reference book has sold more than one million copies, and it has now been revised and updated to include 65 extra pages and more than 1600 photos and step-by-step illustrations. It's a fantastic resource, covering everything from the fundamentals of knitting to more complex techniques, all clearly explained and easy to follow. **£19.99, Sixth & Spring**

NORO KUREYON edited by Jacob Seifert



Curated to mark the 30th anniversary of Kureyon, the colourful yarn from Japanese brand Noro, this book is a joyful celebration of colour. It offers 30 knitting patterns for women's garments, accessories and homewares, showcasing the gorgeous colour changes of Kureyon through the clever use of stitch patterns and shape. Fascinating projects include multi-directional cardigans, modular shawls and blankets, and elegant lace designs. **£17.99, Sixth & Spring**

Recollection

by Renée Callahan

Renée Callahan's latest pattern e-book is filled with the understated elegance and attention to detail we've come to expect from the EastLondonKnit designer.

There are two garment patterns and four accessories in the *Recollection* e-book. Feminine, vintage style abounds with 'A Sweater for Lucille'. It's a top-down, seamless design with chevron stripes and simple lace, sized to fit up to 67in busts. 'Josephine', meanwhile, is a waterfall cardigan with an unusual construction and slip stitch colourwork patterning.

Gorgeous accessories include 'Jo Shawl', an elegant combination of slip stitch stripes and lace, and 'Mabel's Maze', a cowl with a graphic, spiralling colourwork pattern.

Completing the collection is a rectangular striped wrap worked on the bias, called 'Hazel's Stripes', which is designed to use up small amounts of yarn from past projects. 'Pat's Hat' features attractive cables and twisted ribbing, worked in a chunky wool. **£18 for the e-book. Individual patterns cost £4.20 for accessories and £6 for garments from www.ravelry.com/patterns/sources/**



1 The 'Hazel's Stripes' wrap is worked on the bias 2 'A Sweater for Lucille' has a vintage feel 3 'Jo Shawl' uses an elegant slip stitch pattern



DRESS TO IMPRESS Chic dress designs to make you feel special



DECO DREAM DRESS
by Helene Arnesen

Price kr.65 NOK (approx. £6)

www.ravelry.com/patterns/library/deco-dream-dress



CABLE DRESS (DESIGN 04)
by Bergère de France

Price £3.74 as part of the pattern magazine
Plus Sizes (Mag no. 12)

www.bergeredefrance.co.uk



JOHANNA

by Wool and the Gang

Price Free to download from the Rowan website

www.knitrowan.com/en/free-patterns/johanna



zing

ADD *Colour*
TO *Life*

*Gorgeous Light Metal Needles
from*

KnitPro™

FOR THOSE WHO LOVE TO KNIT

www.knitpro.eu

Spring into Wool

75
top class
stalls

"Wonderful show. Loved it, great stalls, and lots to see, do and buy."

7th and 8th April

The Grammar School at Leeds

Workshops
and free
demos

Take a look at some of our wonderful exhibitors...



WENSLEYDALE LONGWOOL SHEEP SHOP

Soft, lustrous knitting yarns in tempting shades from the rare breed Wensleydale Sheep. We also sell combed tops and fleeces, exclusive patterns, garments and more.

www.wensleydalelongwool.co.uk



WATERCOLOURS AND LACE

Beautiful hand-painted yarns in luxurious natural fibres; patterns & kits for knitted and crocheted shawls; cowls and others; crochet kits; fine threads for embroiderers; range of needles and hooks; stitch markers.

www.watercoloursandlace.co.uk



THIRD VAULT YARNS

Your geeky yarn companion providing you with science fiction and fantasy inspired yarns, for that extra hint of fandom in your everyday.

www.thirdvaultyarns.com



WOOLTOPS

Suppliers of finest quality yarns for hand dyeing and knitting, traceable fibres from around the world.

www.wooltops.co.uk

For details: www.springintowool.co.uk or phone 07741 452295

Bo Peep welcomes a new little sister!

Bo Peep, the DK-weight baby yarn from West Yorkshire Spinners, has been joined by a new 4ply option. Made from the same blend of Falkland Island wool and nylon, the yarn is wonderfully soft, light and easy to care for – making it ideal for baby knits.

It is available in 11 lovely shades, including a selection of printed options, with appealing names such as Tooth Fairy, Piglet and Tin Man. Each 50g ball has 200m and costs £3.99.

Accompanying the new yarn launch is a book of patterns for babies, called *Bo Peep Story Book 2* (£9.50). It has 10 charming designs created by Sarah Hatton, including classic jackets and cardigans, pretty dresses with lace details, sweaters and blankets.

www.wyspinners.com 01535 664500



Fluffy! Top your knitted hat with a luxurious hand-made pom-pom from Rowan, made from faux fur

£24 each; find stockists at www.knitrowan.com or call 01484 950630

WORTHY WOOL

Real Good Yarns is a new website, run by Sian Modine, which offers a directory of ethically sourced and environmentally friendly yarns. "It lists suppliers who take extra steps to care for animal welfare, the environment, and the people who produce the yarns," explains Sian. "I will also be offering workshops and talks on the topic of ethical yarns and fibres." Discover more at www.realgoodyarns.co.uk or search @realgoodyarns on social media.

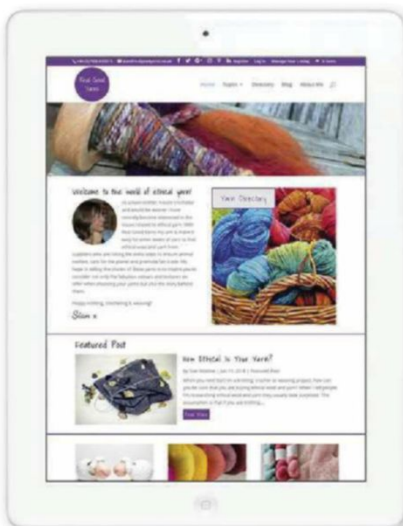

Norwegian TV star **Dorthe Kappel** has created a book of sweater patterns, filled with relaxed designs bursting with modern Nordic style! *Alpaca Knit Sweaters* will be available from April from Amazon.co.uk.



Q&A

Faye Perriam-Reed explains how to embroider bullion stitches

Q I've come across a pattern that calls for bullion stitch embroidery – how do I do that?

A Bullion stitch – also known as bullion knots – can add texture to your knitted fabric, and Jennie Atkinson has used the technique on her 'Cicely' cardigan on page 58. The base for a bullion knot is a simple back stitch, and the width of this back stitch determines the width of your finished knot.

❶ To work the stitch, choose a hole (between two knitted stitches) and bring your embroidery needle through the fabric from the back to the front. Create a back stitch by inserting your needle back through the fabric to the right of where you originally came out, and then bringing the needle back through the original hole – but don't bring it all the way through, just part way. Now twist the working yarn around the needle enough times to equal the width of the back stitch. Gently hold the coiled yarn with your left thumb while you pull the needle through the coil, turn it back on itself and insert it into the hole on the right.

❷ For very small bullion knots, work a back stitch across two knitted stitches; try working across three or four knitted stitches for larger bullion knots.



eucalan
 DELICATE
 wash

lavender
 eucalyptus
 grapefruit
 unscented
 jasmine

the spa treatment for your fine washables

eucalan.com

viridianyarn.com 0117 300 5244

The Island Wool Company

Navia
 Sirri
 Snældan

the home
 of Faroese
 yarns

islandwool.co.uk

WOOL WAREHOUSE

Get **10%** OFF EVERYTHING! Discount code: **TK122**

£8.49 per 100g skein
 Malabrigo Worsted (Aran)
 100% Wool

£4.29 per 170g ball
 Caron Simply Soft (Aran)
 100% Acrylic

Stylecraft Scheepjes WYS RICO DESIGN
 CARON Debbie Bliss SIRDAR Wendy
 erika knight king cole CASCADE YARNS ROWAN C+B
 Louisa Harding
 CRED HEART Fyberspates Opal World of Wool
 THE CRICKET LITE YARN
 TOFT Peter Pan Clover yarn stories PONT
 Sublime malabrigo LOPI
 addi James O'Brett KnitPro Robin
 DMC Patons Noro BERNAT REGIA

We're proud to stock all these leading brands

£2.99 per 50g ball
 Scheepjes Merino Soft (DK)
 Wool, Acrylic & Microfibre blend

£2.99 per 50g ball
 Lopi Lettlopi (Aran)
 100% Wool

WOOL WAREHOUSE
www.woolwarehouse.co.uk

FREE UK DELIVERY on orders over £25

Order online: www.woolwarehouse.co.uk
 Order over the telephone: 01926 882818 or 0800 505 3300
 Email us: hello@woolwarehouse.co.uk
 No minimum order. £2.95 delivery charge for UK orders under £25.
 * Discount code not valid on yarn packs or sale items.

Find yarn treats at Leeds wool show

The Spring Into Wool festival in Leeds on 7-8 April will celebrate all things woolly, including knitting, crochet, spinning and dyeing. Last year's inaugural event proved a big hit with visitors, and the 2018 show is set to be even bigger and better!

There will be 75 stalls selling yarns, tools and more, from popular brands including Baa Ram Ewe and Rooster Yarns, along with a wide range of indie dyers such as The Knitting Swede, Homespunwonders, Watercolours & Lace, and Debonnaire. Visitors can also enjoy craft workshops and watch demonstrations.

The show is being held at The Grammar School in Leeds. Day tickets cost £4.50 in advance or £5 on the door.

For details, visit www.springintowool.co.uk/ or call 07741 452295



So sweet! Fennel the Highland Cow is the newest member of the Knit2Felt family of knitting kits

£30 for the kit, which includes pure wool & alpaca fleece. www.knit2felt.co.uk



World
Craft
Week

16 - 22 APRIL 2018

This year's **World Craft Week** is set for 16-22 April. Join in with fun activities and competitions running all week on social media, plus if you sign up you'll receive a free digital magazine filled with craft projects for you to try.

Find out more at www.worldcraftweek.com

NATIVE BREEDS

Fine Fettle Fibres, the Northumberland yarn shop, has teamed up with local conservation grazing project Flexigraze to offer yarns produced from its native-breed sheep. Manx Loaghtan and Hebridean sheep are used to maintain grassland and heathland habitats, and now their fleeces are being spun at Halifax Mill into aran-weight yarns for handknitting. Each undyed, 100g skein is £14. www.finefettlefibres.uk 01670 600001



DIARY DATES

Events and workshops to inspire your knitting

20 March Oxford

Introduction to Brioche Knitting
www.oxfordyarnstore.co.uk 01865 604112

21 March Liss, Hampshire

Picking Up Stitches for a Round Neckline
www.lisswools.co.uk 01730 893941

23 March Bovey Tracey

Modular/Patchwork Knitting
www.spinayarndevon.co.uk 01626 836203

24 March Morpeth

Learn to Knit a Circular Pi Shawl
www.finefettlefibres.uk 01670 600001

24 March Ipswich

Introduction to Colourwork
www.jennywrensyarns.co.uk
01473 805208

24 March Faversham

Cable Knitting Masterclass
theyarndispensary.co.uk 01795 597 700

28 March Bovey Tracey

Lace Improvers with Anniken Allis
www.spinayarndevon.co.uk 01626 836203

7-8 April Leeds

Spring Into Wool Show
www.springintowool.co.uk

7 April Faversham

Zen and the Art of Seamless Sweater Construction
theyarndispensary.co.uk 01795 597 700

7 April Warrington

Professional Finishing Techniques
www.blacksheepwools.com 01925 764231

14 April Ipswich

Continental Knitting
www.jennywrensyarns.co.uk
01473 805208

14 April Plymouth

The Mar Menor Shawl with Anniken Allis
01752 651878

21 April Sherborne

Learn to Spin
www.theslippedstitch.co.uk 01935 508249

28-29 April Builth Wells

Wonderwool Wales
www.wonderwoolwales.co.uk

Tell us about your event!

theknitter@immediate.co.uk



The most gorgeous yarns, patterns and accessories
WWW.THELOVELIESTYARNCOMPANY.CO.UK

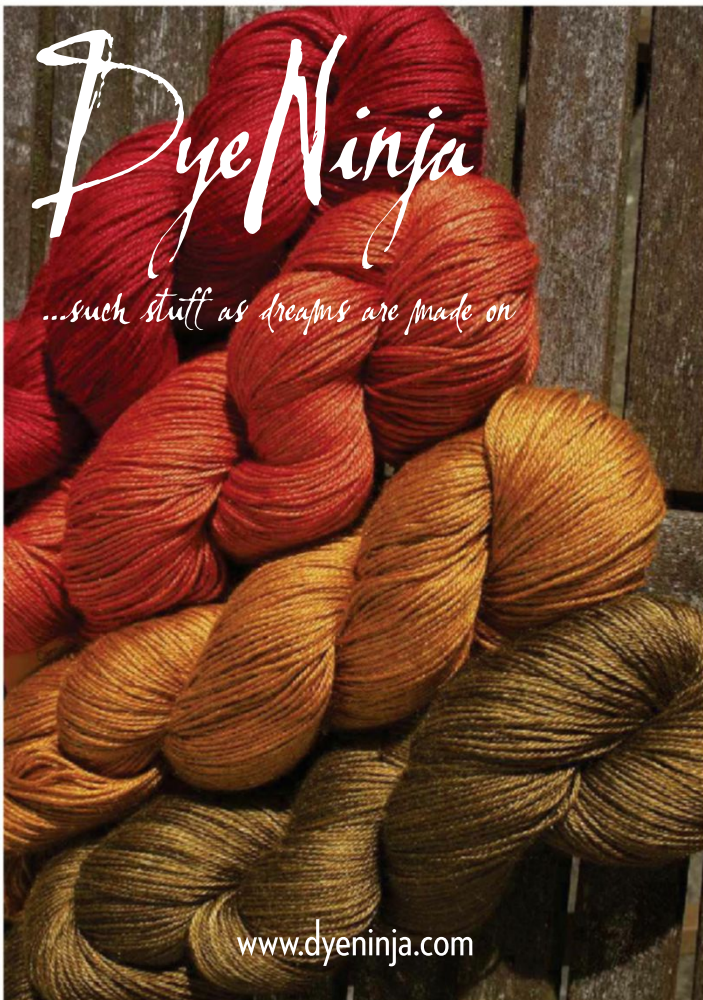

Dye Ninja
...such stuff as dreams are made on

www.dyeninja.com

CASCADE YARNS
 DISTRIBUTOR OF FINE YARN

All these ranges and more available now at Wool Warehouse!



Cascade 220 Fingering
 £3.49 per skein

Cascade 128 Superwash
 From £7.49 per skein

Cascade 220 Superwash
 £7.49 per ball



Cascade 220
 £5.99 per skein

Cascade Heritage
 £7.99 per skein

Cascade Heritage Paints
 £11.99 per skein

*Save 10% on our full range of Cascade yarn and more!**
 Use discount code **TK122** at
www.woolwarehouse.co.uk



Order online: www.woolwarehouse.co.uk
 Order over the telephone: 01926 882818 or 0800 505 3300
 Email us: hello@woolwarehouse.co.uk
* Discount code not valid on yarn packs or sale items.

The Knitter

Save time, money
and hassle
with an annual subscription



GREAT REASONS TO SUBSCRIBE DIGITALLY!

- ⊗ The latest issue is available instantly
- ⊗ Receive a further 13 issues in your first year
- ⊗ All issues download automatically
- ⊗ Download it once... read it offline forever
- ⊗ Your issues won't take up any storage space!

Start
your free
trial
today!*



BRITISH YARNS • JAMIESON & SMITH • FIBERSPATES • YARN STORIES

The Knitter

Create • Knit • Enjoy

Knitting history
The fascinating artefacts
found in shipwrecks

FRESH
NEW
DESIGNS

Gorgeous garments
Accessories for you in
to-wear shapes

Cables
& colour

Sarah Hatton
Classic cabled sweater
Linda Crawford
Fine slip-stitch jumper
Mario Tubiana
Fourwork cardigan

DIAN
Ck pattern
n Taylor

SPOTLIGHT
THE
KNITTING
SWEDE
8-PAGE PULLOUT



To subscribe simply visit:

[www.theyarnloop.com/magazine/
the-knitter/digital](http://www.theyarnloop.com/magazine/the-knitter/digital)

* Free trial not available on Zinio.

The digital version of the magazine may not include any cover gifts that you would find on newsstand copies, and does not include access to Craft Circle.



Emma Vining

Shimmer

Neat, sophisticated cardigan features an interesting cable pattern and pleated details

Shimmer



Ribbed edging bands
are knitted along
with the front pieces



Emma Vining
Shimmer

“MY SHIMMER design uses a series of mirrored cables to create a cardigan with subtle diagonal lines,” says Emma Vining. “Wide rib pleats feature on the lower part of the garment. The cables are worked on the upper sections to create the shimmer. A reverse stocking stitch ridge creates horizontal lines to emphasise the cables.”

“The cable shimmers are made by moving two stitches from each wide rib column edge over the central ‘P2’ of the rib to the next column. This re-ordering of the stitches links the columns and creates the shimmer. Two cable needles are used for the stitch movement.”

BACK

Using 3.25mm needles, cast on 112 (128:144:160:176:192) sts.

Row 1 (RS): K7, *P2, K6; rep from * to last 9 sts, P2, K7.

Row 2 (WS): Knit.
Rep last 2 rows twice more.

Change to 4mm needles.

BEGIN WIDE RIB PATTERN

Row 1 (RS): K7, *P2, K6; rep from * to last 9 sts, P2, K7.

Row 2 (WS): P7, *K2, P6; rep from * to last 9 sts, K2, P7.

Rep last 2 rows 15 more times.

SIZE

	XS	S	M	L	XL	XXL	
TO FIT BUST	76-81	86-94	99-107	112-119	124-132	137-145	cm
	30-32	34-37	39-42	44-47	49-52	54-57	in
ACTUAL BUST	85½	98½	111	123	136	148½	cm
	33¾	38¾	43¾	48½	53½	58½	in
ACTUAL LENGTH	54½	54½	60½	60½	65½	65½	cm
	21½	21½	23¾	23¾	25¾	25¾	in
SLEEVE SEAM	38	38	38	38	38	38	cm
	15	15	15	15	15	15	in

YARN

Yarn Stories Fine Merino DK (DK weight; 100% wool; 120m/131yds per 50g ball)

BLUEBELL (2535)	9	11	13	14	16	18	x50g BALLS
-----------------	---	----	----	----	----	----	------------

NEEDLES & ACCESSORIES

1 pair 3.25mm (UK 10/US 3) knitting needles
1 pair 4mm (UK 8/US 6) knitting needles
Two cable needles (cn)
Stitch holders

TENSION

26 sts and 30 rows to 10cm over Shimmer pattern using 4mm needles.

26 sts and 29 rows to 10cm over Wide Rib pattern using 4mm needles.

BEGIN SHIMMER PATTERN

Row 1 (RS): P13, (K6, P2) 1 (0:1:0:1:0) time, 6-stRPC, (P10, 6-stRPC) 1 (2:2:3:3:4) times, P26, (6-stLPC, P10) 1 (2:2:3:3:4) times, 6-stLPC, (P2, K6) 1 (0:1:0:1:0) time, P13.

Row 2 (WS): K13, (P6, K2) 1 (0:1:0:1:0) time, P2, K2, P2, (K10, P2, K2, P2) 1 (2:2:3:3:4) times, K26, (P2, K2, P2, K10) 1 (2:2:3:3:4) times, P2, K2, P2, (K2, P6) 1 (0:1:0:1:0) time, K13.

Row 3: K7, *P2, K6; rep from * to last 9 sts, P2, K7.

Row 4: P7, *K2, P6; rep from * to last 9 sts, K2, P7.

Rows 5-8: Rep Rows 3-4 twice more.

Row 9: P5, (K6, P2) 1 (0:1:0:1:0) time, 6-stRPC, (P10, 6-stRPC) 2 (3:3:4:4:5) times, (P10, 6-stLPC) 3 (4:4:5:5:6) times, (P2, K6) 1 (0:1:0:1:0) time, P5.

Row 10: K5, (P6, K2) 1 (0:1:0:1:0) time, P2, K2, P2, (K10, P2, K2, P2) 5 (7:7:9:9:11) times, (K2, P6) 1 (0:1:0:1:0) time, K5.

Rows 11-16: Rep Rows 3-4 three more times.

These 16 rows set Shimmer Pattern.

Cont in Shimmer Pattern until piece meas approx. 53 (53:58½:58½:63½:63½) cm from cast-on.

SHAPE RIGHT BACK NECK AND SHOULDER

Row 1 (RS): Cast off 11 (13:15:18:20:23) sts, patt until there are 32 (36:41:45:50:55) sts on RH needle, place rem sts of row on holder. Turn.

Keeping patt correct, cast off 6 sts at beg of next (RS) row, 11 (13:15:17:20:22) sts at beg of next (WS) row, 5 sts at beg of next row, then cast off rem 10 (12:15:17:19:22) sts.

SHAPE LEFT BACK NECK AND SHOULDER

With RS facing, join yarn to held sts and cast off 26 (30:32:34:36:36) sts, patt to end. 43 (49:56:63:70:78) sts.

Keeping patt correct, cast off 11 (13:15:18:20:23) sts at beg of next (WS) row, 6 sts at beg of next (RS) row, 11 (13:15:17:20:22) sts at beg of next row, 5 sts at beg of next row, then cast off rem 10 (12:15:17:19:22) sts.

LEFT FRONT

Using 3.25mm needles, cast on 64 (72:80:88:96:104) sts.

Row 1 (RS): K7, (P2, K6) 5 (6:7:8:9:10) times, K17.

Row 2 (WS): P3, (K2, P2) 3 times, K to end. Rep last 2 rows twice more.

Change to 4mm needles.

BEGIN WIDE RIB PATTERN

Row 1 (RS): K7, (P2, K6) 5 (6:7:8:9:10) times, P2, (K2, P2) 3 times, K3.

Row 2 (WS): P3, (K2, P2) 3 times, K2, (P6, K2) 5 (6:7:8:9:10) times, P7. Rep last 2 rows 15 times more.

BEGIN SHIMMER PATTERN

Row 1 (RS): P13, (K6, P2) 1 (0:1:0:1:0) time,

YARN STOCKISTS

Yarn Stories 01484 848431
www.yarnstories.com

SPECIAL ABBREVIATIONS

Note: To achieve a flat smooth cable, the stitches are reordered as they are worked using two cable needles.

6-stLPC: Slip next 2 sts onto first cn and hold at front; slip next 2 sts onto second cn and hold at back; K2 from LH needle; P2 from second cn; K2 from first cn.

6-stRPC: Slip next 4 sts onto first cn and hold at back; K2 from LH needle; slip first 2 sts on cn onto the second cn and move to front of work; P2 from first cn; K2 from second cn.

For general abbreviations, see p81

BLOCKING DIAGRAM

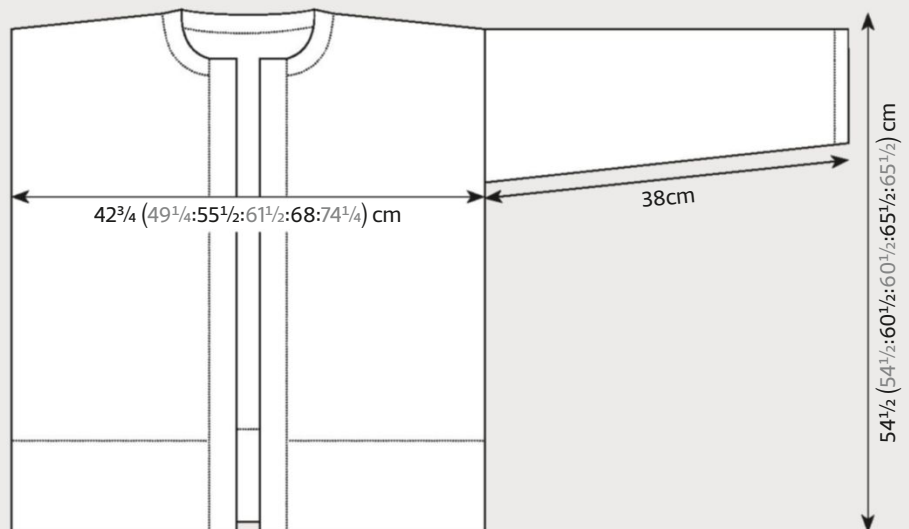

6-stRPC, (P10, 6-stRPC) 1 (2:2:3:3:4) times, P6, (K2, P2) 3 times, K3.

Row 2: P3, (K2, P2) 3 times, K6, P2, K2, P2, (K10, P2, K2, P2) 1 (2:2:3:3:4) times, (K2, P6) 1 (0:1:0:1:0) time, K13.

Row 3: K7, (P2, K6) 5 (6:7:8:9:10) times, P2, (K2, P2) 3 times, K3.

Row 4: P3, (K2, P2) 3 times, K2, (P6, K2) 5 (6:7:8:9:10) times, P7.

Rows 5-8: Rep Rows 3-4 twice more.

Row 9: P5, (K6, P2) 1 (0:1:0:1:0) time, (6-stRPC, P10) 2 (3:3:4:4:5) times, P4, (K2, P2) 3 times, K3.

Row 10: P3, (K2, P2) 3 times, K4, (K10, P2, K2, P2) 2 (3:3:4:4:5) times, (K2, P6) 1 (0:1:0:1:0) time, K5.

Rows 11-16: Rep Rows 3-4 three more times.

These 16 rows set Shimmer Pattern.

Cont in Shimmer Pattern until piece meas approx. 22 (24:26:28:30:32) rows [7½ (8:9:9½:10:11) cm] shorter than Back to start of shoulder shaping, ending after a WS row.

SHAPE LEFT FRONT NECK AND SHOULDER

Next row (RS): Patt 47 (55:63:71:79:87), turn, leaving rem 17 sts of row on holder. Keeping patt correct, cast off 6 (6:6:7:7:7) sts at beg of next (WS) row, then dec 1 st at neck edge of every row 5 times, then every foll alt row 4 (6:7:7:8:8) times. 32 (38:45:52:59:67) sts.

Work 7 (5:5:7:7:9) rows even in patt, ending

after a WS row.

Cast off 11 (13:15:18:20:23) sts at beg of next RS row, 11 (13:15:17:20:22) sts at beg of next RS row, then cast off rem 10 (12:15:17:19:22) sts on foll RS row.

RIGHT FRONT

Using 3.25mm needles, cast on 64 (72:80:88:96:104) sts.

Row 1 (RS): K17, (K6, P2) 5 (6:7:8:9:10) times, K7.

Row 2 (WS): K to last 15 sts, (P2, K2) 3 times, P3.

Rep last 2 rows twice more.

Change to 4mm needles.

BEGIN WIDE RIB PATTERN

Row 1 (RS): K3, (P2, K2) 3 times, P2, (K6, P2) 5 (6:7:8:9:10) times, K7.

Row 2 (WS): P7, (K2, P6) 5 (6:7:8:9:10) times, K2, (P2, K2) 3 times, P3.

Rep last 2 rows 15 more times.

BEGIN SHIMMER PATTERN

Row 1 (RS): K3, (P2, K2) 3 times, P6, (6-stLPC, P10) 1 (2:2:3:3:4) times, 6-stLPC, (P2, K6) 1 (0:1:0:1:0) time, P13.

Row 2 (WS): K13, (K6, P2) 1 (0:1:0:1:0) times, (P2, K2, P2, K10) 1 (2:2:3:3:4) times, P2, K2, P2, K6, (P2, K2) 3 times, K3.

Row 3: K3, (P2, K2) 3 times, P2, (K6, P2) 5 (6:7:8:9:10) times, K7.

Row 4: P7, (K2, P6) 5 (6:7:8:9:10) times, K2, (P2, K2) 3 times, P3.

Rows 5-8: Rep Rows 3-4 twice.

Row 9: K3, (P2, K2) 3 times, P4, (P10, 6-stLPC) 2 (3:3:4:4:5) times, (P2, K6) 1 (0:1:0:1:0) time, P5.

Row 10: K5, (P6, K2) 1 (0:1:0:1:0) time, (P2, K2, P2, K10) 2 (3:3:4:4:5) times, K4, (P2, K2) 3 times, P3.

Rows 11-16: Rep Rows 3-4 three times. These 16 rows set Shimmer Pattern.

Cont in Shimmer Pattern until piece meas approx. 23 (25:27:29:31:33) rows [7½ (8:9:9½:10:11) cm] shorter than Back to start of shoulder shaping, ending after a RS row.

SHAPE LEFT FRONT NECK AND SHOULDER

Next row (WS): Patt 47 (55:63:71:79:87), turn, leaving rem 17 sts of row on holder. Keeping patt correct, cast off 6 (6:6:7:7:7) sts at beg of next (RS) row, then dec 1 st at neck edge of every row 5 times, then every foll alt row 4 (6:7:7:8:8) times. 32 (38:45:52:59:67) sts.

Work 8 (6:6:8:8:10) rows even in patt, ending after a RS row.

Cast off 11 (13:15:18:20:23) sts at beg of next WS row, 11 (13:15:17:20:22) sts at beg of next WS row, then cast off rem 10 (12:15:17:19:22) sts on foll WS row.

SLEEVES

(both alike)

Using 3.25mm needles, cast on 64 (64:72:72:80:88) sts.

Shimmer

Row 1 (RS): K3, (P2, K6) 7 (7:8:8:9:10) times, P2, K3.

Row 2 (WS): Knit.

Rep last 2 rows twice more.

Change to 4mm needles.

BEGIN WIDE RIB PATTERN

Row 1 (RS): K3, (P2, K6) 7 (7:8:8:9:10) times, P2, K3.

Row 2 (WS): P3, (K2, P6) 7 (7:8:8:9:10) times, K2, P3.

These 2 rows set the pattern.

Note: Work increases 2 sts in from each edge.

Keeping patt correct, inc 1 st at each end of 5th (5th:5th:5th:3rd:3rd) row, then every foll 10th (6th:6th:4th:4th:4th) row 8 (14:14:19:21:23) times more.

82 (94:102:112:124:136) sts.

Work even in patt until work meas 38cm, ending after a WS row.

Cast off in patt.

FINISHING

Block pieces gently to measurements, following any yarn care instructions on the ball band.

Join shoulder seams.

NECKBAND

With RS facing and using 3.25mm needles, across 17 sts held for right front: K3, (P2, K2) 3 times, P2; pick up and knit 26 (28:30:33:35:37) sts to shoulder seam, 48 (52:54:56:58:58) sts across back neck, pick up and knit 26 (28:30:33:35:37) sts down left front neck to holder, then across 17 sts held for left front: P2, (K2, P2) 3 times, K3.

134 (142:148:156:162:166) sts.

Row 1 (WS): P3, (K2, P2) 3 times, K to last 15 sts, (P2, K2) 3 times, P3.

Row 2 (RS): K3, (P2, K2) 3 times, P2, K to last 17 sts, P2, (K2, P2) 3 times, K3.

Rep last 2 rows 3 more times.

Cast off in pattern on WS.

Mark centre point of sleeve cast-off. Match this point to shoulder seam and pin sleeve in place evenly on either side of seam. Sew sleeve in place. Repeat for second sleeve.

Sew underarm seams.

Sew side seams.

Weave in ends. ☸

The sleeves and lower body are worked in a pleated pattern





Hand dyed luxury yarns from North Yorkshire

Each skein in our shop is hand dyed, with love and care. Most of our yarns contain silk or cashmere.

We dye small limited editions only, so your projects will always be unique.

northshireyarns.co.uk
 northshireyarn@gmail.com
 northshireyarns_anni

Homespunwonders

Craft accessories, hand dyed yarn, textiles and gifts

Yorkshire Dale Yarn

Beautiful yarn and gift boxes...

All our yarn is hand dyed by us in Yorkshire with the colours inspired by the beautiful flora and fauna of the Yorkshire Dales

Use the code: KNIT122 to get a 15% off discount

www.homespunwonders.etsy.com



DesignaKnit8
 Soft Byte LTD

- Standard Garment Styling
- Original Pattern Drafting
- Stitch Designer
- Graphics Studio
- Interactive Knitting

For info call UK 01691 828556 or visit www.softbyte.co.uk

CHOOSE YOUR PACKAGE

HandKnit - Just for hand knitters!
 Machine Standard
 Machine Pro
 Complete = Hand+machine

FULLY UPDATED FOR CURRENT WINDOWS



DOWNLOAD THE KNITTER NOW!

You can buy a digital edition of *The Knitter* - ready to read whenever you want. Single issues and subscriptions are available, and every issue you purchase is stored in your magazine library permanently.

Once your magazine has downloaded, an internet connection is not required so you can take your magazine with you, wherever you go.

To buy your digital copy, visit www.theyarnloop.com/magazine/the-knitter/digital



Best of the best!

From designers and retailers to bloggers and brands, we reveal the yarn craft winners from the British Craft Awards!

THE CRAFTING community joined together on 18th February to celebrate the very best our industry has to offer. The prestigious British Craft Awards give crafters around the country the chance to name the designers, companies and products that have really made their year. The winners were announced at a special evening ceremony at CHSI Stitches, the UK's trade show for the creative craft industry. The teams from *The Knitter* and our sister magazine, *Simply Knitting*, were delighted to be able to present awards to six worthy winners in the knitting sector, as voted for by our readers – so read on to discover all the champions and runners-up!



The awards were presented at the Stitches trade show



PRODUCT OF THE YEAR
WINNER

Addi circular needles

The Addi brand prides itself on offering high-quality products for knitters, and this family company has been making its needles in Germany for 189 years! Voters picked Addi's circular needles as their product of the year, thanks to their flexible cords, lightweight tips, and smooth joins between cord and needle tips.

Fixed circulars come in a huge range of sizes from 1.5mm up to 25mm; there are also the special Addi Lace needles with extra-sharp points for accuracy, and the Addi Click system of interchangeables.

Addi needles are distributed in the UK by Rooster Yarns. Find stockists at www.roosteryarns.com/addi-circular-knitting-needles

2ND PLACE Eucalan No Rinse Delicate Wash

3RD PLACE Rowan Alpaca Soft DK



DESIGNER OF THE YEAR
WINNER

Woolly Wormhead

Innovative designer Woolly Wormhead describes herself as a 'hat architect', and it's no surprise that her clever, stylish hats have won her so many fans.

Woolly loves to combine unusual construction techniques and intriguing stitch combinations, ensuring that her designs are always entertaining to knit. She is a great teacher, too, sharing her knowledge with other knitters through her online tutorials and workshops. "It was a surprise to be nominated for Knitting Designer of the Year, and even more of a surprise to win!" said Woolly. "I really can't thank everyone enough for their support."

Find Woolly Wormhead's designs and tutorials at www.woollywormhead.com

2ND PLACE Debbie Bliss **3RD PLACE** Anniken Allis



**BLOG OF THE YEAR
WINNER**
Little Cotton Rabbits

Designer Julie Williams runs the website Little Cotton Rabbits, where she shares stories of her knitting adventures, inspirational photos of her surroundings in rural Hertfordshire, and insights into life in as a mum to a severely autistic son. Julie specialises in creating charmingly characterful toy designs, and knitters love her sweet bunnies, bears, sheep, cats, elephants and more. "I'm blown away!" says Julie. "The blog is a way for me to share my love of knitting, and I'm constantly grateful to all of the people who pop by to visit with me, taking the time to leave kind comments, support and friendship."

Read Julie's blog at
www.littlecottonrabbits.typepad.co.uk

2ND PLACE KnitBritish.net
3RD PLACE NeverNotKnitting.com



**RETAILER OF THE YEAR
WINNER**
Wool Warehouse

Online yarn store Wool Warehouse scooped the prize for Retailer of the Year, thanks to votes from its many loyal fans. Voters praised Wool Warehouse's customer service, huge choice of yarns, great prices, and lovely packaging – "they're brilliant all round!", said one voter. It's run by Holly and Andy, and as well as having a big online presence, Wool Warehouse still operates a bricks-and-mortar yarn store in Leamington Spa.

The team sells yarns from an impressive 36 of the most popular brands, as well as 14 needle brands, all the buttons and notions you'd ever need, knitting books, fabric, and so much more! "Thank you very much for all the votes, we're honoured to win!" said Ellie Malin from Wool Warehouse.

Discover the full range at www.woolwarehouse.co.uk

2ND PLACE Love Knitting
3RD PLACE Black Sheep Wools



**BRAND OF THE YEAR
WINNER**
Rowan

Yorkshire company Rowan has been at the forefront of yarn innovation for 40 years, so it was no surprise to see it has been named as your favourite brand. Its much-loved yarns include both perennial favourites such as Felted Tweed and Kidsilk Haze, and exciting new blends for 2018 including Cotton Cashmere and Denim Lace. Rowan is also hugely admired for its gorgeous pattern collections. "We're so happy with this win!" said Sharon Brant from Rowan. "We've had a challenging 18 months, so it really means a lot to us."

You can see all of Rowan's yarns and patterns at
www.knitrowan.com

2ND PLACE Stylecraft **3RD PLACE** Jamieson & Smith



**SPECIAL AWARD
CRAFT HERO**

West Yorkshire Spinners

The organisers of the British Craft Awards presented a special award to Richard Longbottom, sales and marketing manager of West Yorkshire Spinners. This family business is the worthy winner of our Craft Hero award, as it has been hugely important in keeping the British spinning industry alive. The team at West Yorkshire Spinners always impress us with their innovative and expert approach, and their focus on using local materials, to create truly outstanding British yarns.

See all of West Yorkshire Spinners' yarns and designs at www.wyspinners.com

SWATCHES
SHOWN
ACTUAL
SIZE



New yarns

Gorgeous colour, soft fabrics and even a touch of sparkle are on offer from the best new yarns, available in shops and online



SUBLIME Eden

Shade pictured **Renee (637)**
Ball weight/length **150g/498m**
Needle size **4mm (UK 8/US 6)**
Tension **22 sts and 28 rows to 10cm**
Fibre content **55% wool, 45% cotton**
Care **Hand wash** RRP **£21.17**
Contact **01924 369666**
www.sublimeyarns.com

Multi-coloured yarn cakes are hugely popular right now, and Sublime's version for spring and summer is a fantastic choice. The lightweight cotton-wool blend gives a cool, matt look and feel to the fabric, and the stitches are well defined. The six colourways offer vivid brights and muted shades, and Sublime's pattern support makes the most of the block colour effects.



ROMNEY MARSH British Romney Lambswool DK

Shade pictured **Ecru**
Ball weight/length **100g/209m**
Needle size **4mm (UK 8/US 6)**
Tension **18 sts and 24 rows to 10cm**
Fibre content **100% wool**
Care **Hand wash** RRP **£8.00**
Contact **01233 721 800**
www.romneymarshwools.co.uk

This new British lambswool is a lovely classic DK, which feels softly crisp and characterful in the hand and knits up into a fabric full of bounce. When washed, a subtle halo blooms across the stitches, which sit evenly and show off a warming semi-lustrous glow. Natural fleece shades are blended to create four beautifully soft shades of cream and grey.



EDEN COTTAGE YARNS Nateby 4ply

Shade pictured **Misty Woods**
 Skein weight/length **100g/400m**
 Needle size **2.5-4mm (UK 13-8/US 1-6)**
 Tension **25 sts and 38 rows to 10cm**
 Fibre content **75% superwash merino wool, 20% nylon, 5% silver Lurex**
 Care **Machine wash RRP £20**
 Contact **www.edencottageyarns.co.uk**

Jump-start your spring with Eden Cottage Yarns' new Nateby, a luxurious merino blend that carries a touch of silver to sparkle up your knitwear. The muted colour palette is full of gorgeous hand-dyed hues, ranging from semi-solids to more variegated shades. Wonderfully soft and plump, Nateby will be perfect for lovely, draping knits with a bit of cheeky glimmer.



BAA RAM EWE Pip Colourwork

Shade pictured **Lotherton**
 Ball weight/length **25g/116m**
 Needle size **2.75-3.25mm (UK 12-10/US 2-3)**
 Tension **27 sts and 36 rows to 10cm**
 Fibre content **100% wool**
 Care **Hand wash RRP £3.20**
 Contact **0113 278 1788**
www.baaramewe.co.uk

Baa Ram Ewe is going from strength to strength with yet another fantastic yarn, and it's a thing of beauty! Pip is a soft and woolly 4ply that would be perfect for colourwork and stripes, with a range of 15 shades that work together beautifully. This yarn flows through the fingers to create a fabric with excellent bounce and a pleasing halo.

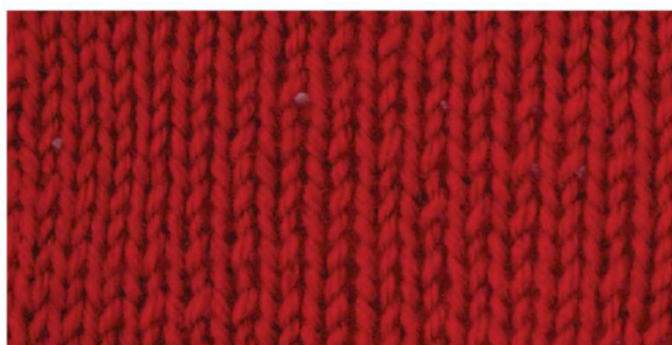

WILLOW & LARK Ramble

Shade pictured **Cranberry (111)**
 Ball weight/length **50g/125m**
 Needle size **4mm (UK 8/US 6)**
 Tension **22 sts and 30 rows to 10cm**
 Fibre content **100% merino wool**
 Care **Machine wash 40°C RRP £4.39**
 Contact **www.loveknitting.com**

Willow & Lark's new Ramble will be a great go-to yarn for any knitting projects that need a soft touch and fantastic stitch definition. Its plump and rounded spin means a zingy spring as you knit, and a fabric with warmth and drape. And it has a colour palette that just won't quit, with 30 shades including soft neutrals, deep jewelled tones and sophisticated pastels.



SCHEEPJES Our Tribe

Shade pictured **Felted Button (965)**
 Ball weight/length **100g/420m**
 Needle size **2.5-3mm (UK 13-11/US 1-3)**
 Tension **28 sts and 40 rows to 10cm**
 Fibre content **70% superwash merino wool, 30% polyamide**
 Care **Machine wash 40°C RRP £7.99**
 Contact **www.scheepjes.com**

With a colour palette developed in collaboration with the Scheepjes Blogger Group, Our Tribe is a feathery-soft sportweight that will knit up into lightweight garments and accessories. The single-ply yarn holds a delicious glow that gleams through a downy halo. There are 24 shades in all, featuring 15 variegated and nine complementary solid hues.

Great reads

We review a new pattern collection of wardrobe essentials, offering everyday wearability and thoughtful details

PLAIN & SIMPLE

by Pam Allen (£17.20)

WHAT MAKES a favourite sweater? That's the question Pam Allen pondered when designing this book of wardrobe essentials. Her mission was to create classic sweaters that would be straightforward to knit and wear, yet which would be treasured and enjoyed by the people who make them.

The title of her collection is *Plain & Simple*, but that doesn't mean the patterns are boring! The 11 designs do use simple stitches and shapes; there are enough interesting details, however, to keep knitters entertained, and the results will offer a wearable sophistication. As Pam points out in her introduction, these projects are ideal for working on while watching a movie or listening to a podcast!

All the sweater in the book are knitted using undyed shades of Quince & Co. Owl, a worsted-weight blend of wool and alpaca. They are designed to have a decent amount of positive ease - at least eight inches, in most cases - and will fit busts of up to 56in comfortably.

The first project created for the book was 'Ash'. It's an extra-wide, almost square sweater with a modified dolman shape - the body is worked from the bottom up, then the sleeves are picked up and knitted down. Pockets are set into the deep lower border, which is worked in half-brioche stitch, while the graceful shoulder lines are emphasised by exposed seams.

The pretty 'Willow' sweater features gansey-inspired knit-and-purl patterning around the shoulders and sleeve tops, while 'Birch' is a colourwork yoked jumper, designed for a loose, oversized fit.

'Aspen' is the most fitted project in the book; this neat jumper has a slip stitch pattern around the yoke, which adds subtle texture as well as colour.

The 'Larch' sweater, meanwhile, has to be the ultimate cover-up! Its body is a simple rectangle that's almost as wide as it is tall, worked entirely in stocking stitch

except for the ribbed edges. Finishing details include pockets and a cowl neck. The size range for this project spans from 33in right up to 70in, so you can make it narrow for a neater fit, or wide and swifty, depending on your preference.

Cardigans include the slim-fitting 'Maple', which has wide front borders worked in brioche stitch for textural interest. 'Walnut' has a high, round neckline, slim sleeves, vented side seams for ease of movement, and pockets. Its cuffs and borders are worked in half-brioche, a variation on classic brioche rib.

Completing Pam's collection are a striped beanie, and 'Balsam', a versatile accessory that can be worn as a cowl or a hood. ☺

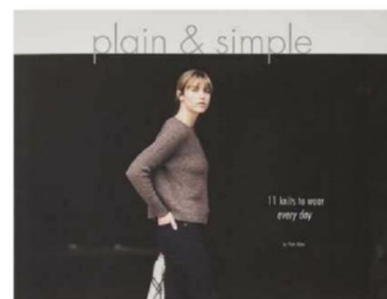

Plain & Simple is published by Quince & Co., priced £17.20. For details, visit www.quinceandco.com. Print copies are available in the UK from www.amazon.co.uk. PDF versions can be purchased from Ravelry: <http://bit.ly/allenps>



PHOTOGRAPHY © WHITNEY HAYWARD

GET THE LATEST ISSUE!

WELLBEING * PAPER ARTS * CREATIVITY * TRAVEL * YOGA

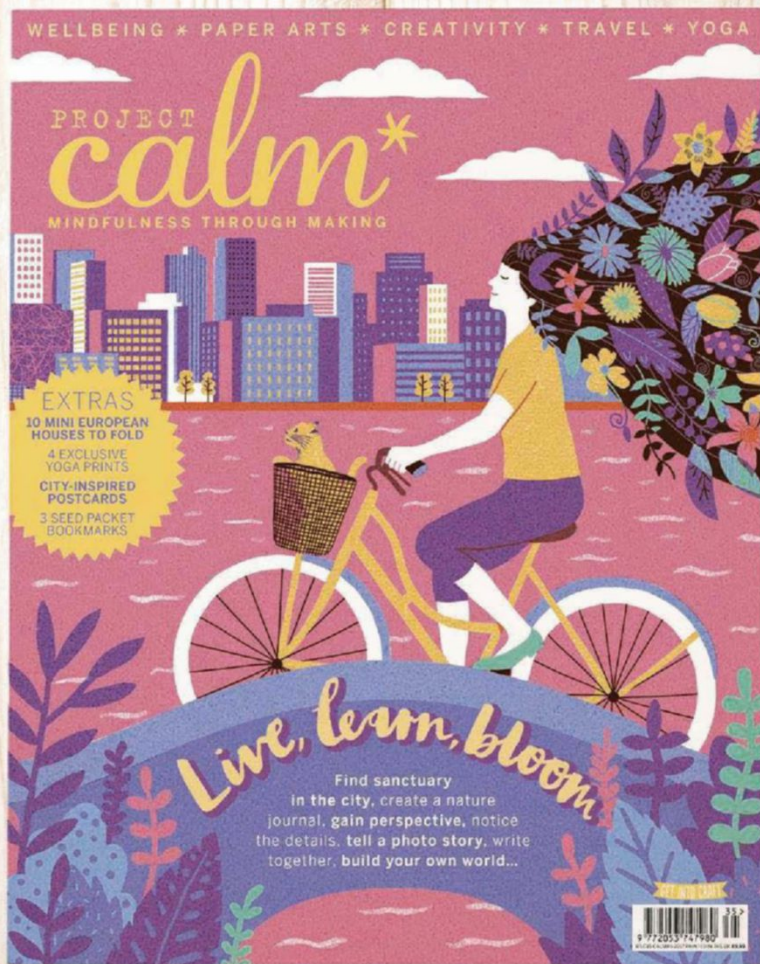

PROJECT
*calm**

Welcome to our beautiful magazine packed with creative projects & ideas, gorgeous photography and insightful features. Discover new ways to bring the joys of mindfulness & making into your life.

£9.99*
[SPRING 2018]

EXTRAS

10 MINI EUROPEAN HOUSES TO FOLD
4 EXCLUSIVE YOGA PRINTS
6 CITY-INSPIRED CARDS & ENVELOPES
3 SEED PACKET BOOKMARKS

EXTRAS IN THIS ISSUE INCLUDE...



Seed packet bookmarks to fold, fill and give away.



Four exclusive, quality yoga prints to pin up or frame.



Six city postcards and cards to send with envelopes.



Keep track of good ideas with our pull-out wall planner.



Build a mini European street scene with cut-out templates.

ORDER YOUR COPY TODAY

ORDER ONLINE WWW.BUYSUBSCRIPTIONS.COM/CRAFTSPECIAL
OR CALL 03330 162 138 AND QUOTE 'CALM 7 PRINT 1'

Lines open weekdays 8am to 6pm and Saturday 9am to 1pm. Overseas please call +44 (0) 3330 162 138.
* EUR price £11.99, ROW price £12.99. All prices include P&P. Please allow up to 28 days for delivery.

**NEW
ISSUE!**



SNUGGLY BLANKETS



EASTER PATTERNS



GORGEOUS GARMENTS



CUTE CARDIES

Love Knitting for Baby

Only
£5.99
including
p&p



Don't miss it!

Looking for some spring inspiration? The April issue of *Love Knitting for Baby* is packed with ideas for babies and toddlers – from snuggly blankets to cute cardies, plus a bonus pattern book! Don't miss out – order your copy today...

At just £5.99 this issue includes:

- 52-page collection of royal baby knits
- Super baby knits for spring
- Gifts & nursery makes
- Patterns for all skill levels



**ORDER
YOUR COPY
TODAY**

ORDER YOUR COPY TODAY!

CALL 03330 162 138 and quote 'Love Knitting April 18'
ONLINE www.buysubscriptions.com/craftspecial

Lines open weekdays 8am to 6pm and Saturday 9am to 1pm for orders only.
Overseas please call +44 (0) 3330 162 138 EUR price £7.99, ROW price £8.49. All prices include p&p.



Sarah Hatton
Pippa

Pretty as a picture! This cardigan for baby girls has a sweet little peplum



Sarah Hatton
Pippa

SARAH HATTON'S cardigan design for baby girls has an old-fashioned feel, with its softly textured fabric and little peplum. It's knitted in one piece to the armholes, and includes moss stitch edgings. The project uses the new 4-ply-weight version of West Yorkshire Spinners' soft Bo Peep yarn, which is an easy-care blend of Falkland Islands wool and nylon, and comes in solid and speckled pastel colourways.

BODY

(worked in one piece to armhole)
Using 2.75mm needles, cast on 161 (169:177:181:185) sts. (The long-tail or thumb cast-on will give the neatest finish).

Row 1: K1, (P1, K1) to end.
This row sets moss stitch.
Work 5 rows more in moss stitch.

Change to 3.25mm needles.
Next row (RS): Moss st 5, knit to last 5 sts, moss st 5.
Next row: Moss st 5, purl to last 5 sts, moss st 5.
Rep these 2 rows until work meas 5cm, ending with RS facing for next row.

Change to 2.75mm needles.
Next row (RS): Moss st 5, K9 (6:4:6:8), *sk2po, K7 (8:9:9:9); rep from * 12 more times, sk2po, K9 (7:4:6:8), moss st 5. 133 (141:149:153:157) sts.

Place marker at each end of last row.

SIZE

TO FIT CHEST	0-3 mths	3-6 mths	6-9 mths	9-12 mths	12-18 mths	
	40½	43	44	45½	48	cm
	16	17	17½	18	19	in
ACTUAL CHEST	50	52½	55½	57	58	cm
	20	20¾	22	22¼	23	in
ACTUAL LENGTH	27	29	30	32	33	cm
	10½	11¼	11¾	12½	13	in
SLEEVE SEAM	12	15	17	19	21	cm
	4¾	6	6¾	7½	8¼	in

YARN

West Yorkshire Spinners Bo Peep 4ply (4ply weight; 52% Falkland wool, 48% nylon; 200m/218yds per 50g ball)

TIN MAN (305)	2	2	2	3	3	x50g BALLS

NEEDLES & ACCESSORIES

1 pair 2.75mm (US 2/UK 12) knitting needles
1 pair 3.25mm (US 3/UK 10) knitting needles
Stitch holders
3 buttons

TENSION

28 sts and 36 rows to 10cm over st st and patt on 3.25mm needles

YARN STOCKISTS

West Yorkshire Spinners
01535 664500
www.wyspinners.com

Work 5 rows in moss st, ending with RS facing for next row.

Change to 3.25mm needles.

Row 1 (RS): Knit.

Row 2: Purl.

Row 3: K2 (2:2:4:2), *P1, K3; rep from * to last 3 (3:3:1:3) sts, P1 (1:1:0:1), K2 (2:2:1:2).

Row 4: Purl.

Row 5: Knit.

Row 6: P4 (4:4:2:4), *K1, P3; rep from * to last 1 (1:1:3:1) sts, K0 (0:0:1:0), P1 (1:1:2:1).

These 6 rows set pattern.

Working as set throughout, cont until work meas 13 (15:16:18:19) cm, ending with RS facing for next row.

SPLIT FOR ARMHOLES

Next row: K29 (31:33:34:35), cast off 6 sts (1 st left on needle), knit until there are 63 (67:71:73:75) sts after cast-off, cast off 6 sts (1 st left on needle), knit to end.

Cont on the last 29 (31:33:34:35) sts only for left front.

Work 1 row, ending with RS facing for next row.

SHAPE ARMHOLES AND FRONT NECK

Next row: K2, skpo, patt to last 4 sts, K2tog, K2. 2 sts dec'd.

Next row: P3, patt to last 4 sts, P2tog tbl, P2. 2 sts dec'd.

These 2 rows set armhole and front neck shaping.

Working 3 sts at each edge in st st and all other sts in patt, dec 1 st at armhole edge as

set on next 3 rows, then on 3 foll RS rows and AT THE SAME TIME dec 1 st at neck edge of every foll RS rows.
17 (19:21:22:23) sts.

Dec 1 st at neck edge only of 2nd and every foll 4th row to 11 (12:13:14:15) sts.

Cont without shaping until armhole meas 11 (11:12:12:13) cm, ending with RS facing for next row.

SHAPE SHOULDER

Next row: Cast off 5 (6:6:6:7) sts, knit to end.

Work 1 row.
Cast off rem 6 (6:7:8:8) sts.

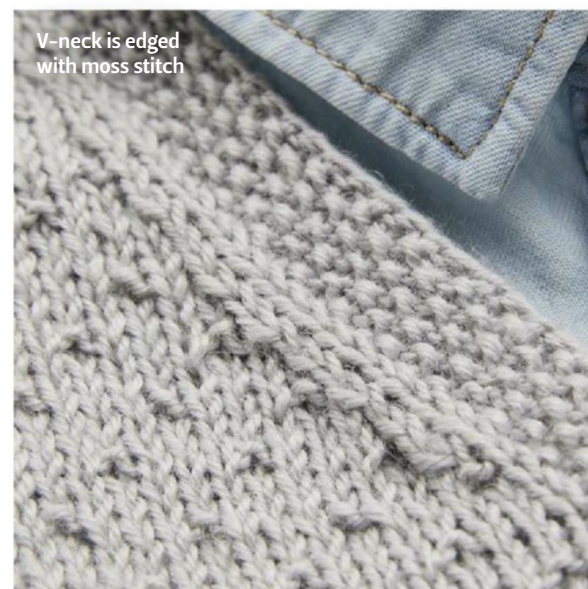

BLOCKING DIAGRAM

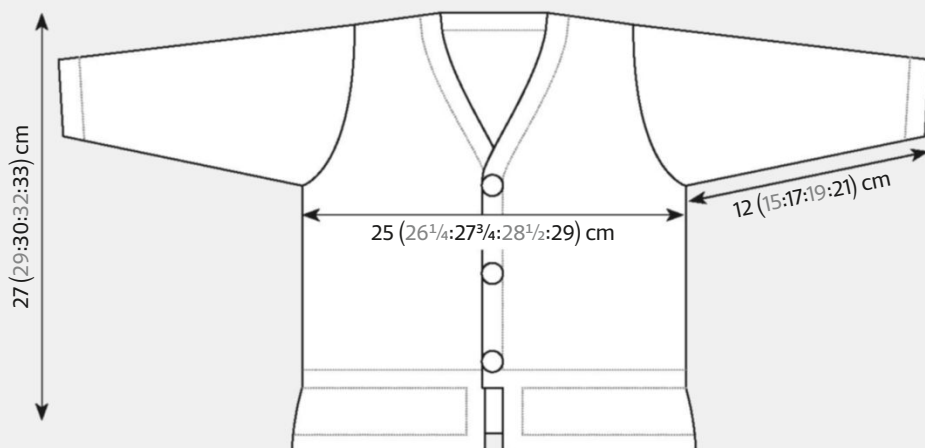

For general abbreviations, see p81

The little peplum is a pretty detail



With WS facing, rejoin yarn to 63 (67:71:73:75) sts for Back, purl to end.

Next row: K2, skpo, knit to last 4 sts, K2tog, K2. 2 sts dec'd.

Next row: P2, P2tog, purl to last 4 sts, P2tog tbl, P2. 2 sts dec'd.

These 2 rows set armhole shaping. Dec 1 st as set at each end of next 3 rows, then on 3 foll RS rows. 47 (51:55:57:59) sts.

Cont without shaping until armhole matches Left Front to start of shoulder shaping, ending with RS facing for next row.

SHAPE SHOULDERS

Cast off 5 (6:6:6:7) sts at beg of next 2 rows and 6 (6:7:8:8) sts at beg of foll 2 rows. 25 (27:29:29:29) sts. Cast off rem sts.

With WS facing, rejoin yarn to rem 29 (31:33:34:35) sts for right front. Work 1 row, ending with RS facing for next row.

SHAPE ARMHOLES AND FRONT NECK

Next row: K2, skpo, patt to last 4 sts, K2tog, K2. 2 sts dec'd.

Next row: P2, P2tog, patt to last 3 sts, P3. These 2 rows set armhole and front neck shaping.

Working 3 sts at each edge in st st and all other sts in patt, dec 1 st at armhole edge as set on next 3 rows, then on 3 foll RS rows

and AT THE SAME TIME dec 1 st at neck edge of every foll RS rows. 17 (19:21:22:23) sts.

Dec 1 st at neck edge only of 2nd and every foll 4th row to 11 (12:13:14:15) sts.

Cont without shaping until armhole meas 11 (11:12:12:13) cm, ending with WS facing for next row.

SHAPE SHOULDER

Next row: Cast off 5 (6:6:6:7) sts, purl to end.

Work 1 row. Cast off rem 6 (6:7:8:8) sts.

SLEEVES

Using 2.75mm needles, cast on 37 (37:39:39:41) sts.

Work 6 rows in moss st as set on Body, ending with RS facing for next row.

Change to 3.25mm needles. Beg with a K row and working in st st throughout, inc 1 st at each end of 3rd and 6 (1:0:7:7) foll 2nd (2nd:0:4th:4th) row, then on every foll 4th (4th:4th:6th:6th) row to 59 (59:65:65:69) sts.

Cont without shaping until Sleeve meas 12 (15:17:19:21) cm, ending with RS facing for next row.

SHAPE SLEEVE TOP

Cast off 3 sts at beg of next 2 rows. 53 (53:59:59:63) sts.

Working decreases as set on Back, dec 1 st at

each end of next 5 rows, then on 2 foll RS rows. 39 (39:45:45:49) sts.

Work 1 row, ending with RS facing for next row.

Cast off 5 (5:6:6:6) sts at beg of next 6 rows. 9 (9:9:9:13) sts.

Cast off rem sts.

MAKING UP

Using mattress stitch, join shoulder seams.

NECKBAND

With RS facing, using 2.75mm needles, pick up and knit 25 (30:34:37:39) sts up right front edge from marker to start of neck shaping, 34 (34:37:37:41) sts up neck shaping, 25 (25:25:27:27) sts from back neck, 34 (34:37:37:41) sts down left front neck and 25 (30:34:37:39) sts to marker. 143 (153:167:175:187) sts.

Working in moss stitch as set on Body throughout cont as follows:-

Work 3 rows.

Next row: Patt 3, *cast off 2 sts (1 st left on needle), patt 6 (8:9:11:12); rep from * once more, cast off 2 sts (1 st left on needle), patt to end.

Next row: Patt to end, casting on 2 sts over each gap created by casting off on previous row.

Work 3 rows.

Cast off in patt.

Join sleeve seams. Sew in sleeves, matching cast-offs and decreases then easing remaining fabric in to place.

Sew on buttons. ☺

12 FAB
STITCHES TO LEARN

JOIN OUR HOOK 'N' LEARN & GET YOUR SCHEEPJES YARN PACK WHEN YOU SUBSCRIBE

Collect the patterns every issue to make this gorgeous blanket!



Scheepjes
INSPIRATION IN EVERY BALL OF YARN



WORTH
£24.95!

You'll get all the yarn to make our Hook 'n' Learn blanket!



Dear reader,
We're so excited to launch our new Hook 'n' Learn blanket project! To celebrate, we're offering you an extra-special LIMITED TIME offer! Subscribe to *Simply Crochet* today and you'll receive a huge **9-ball bundle of Scheepjes Colour Crafter yarn** – enough to make the blanket. PLUS you'll pay just £29.99 every 6 issues – saving you £1 every issue! Each issue, you'll receive the next Hook 'n' Learn instalment, helping you master 12 gorgeous crochet stitches across the year, before transforming them into this beautiful completed blanket. (The first few patterns will be available for you at www.simplycrochetmag.co.uk.) Plus, every issue's bursting with more than **20 beautiful crochet patterns** for gifts, garments, accessories and more, not to mention a FREE gift too. Don't miss the fun – subscribe today!

Sara

- Get a Scheepjes Colour Crafter yarn bundle to make our Hook 'n' Learn blanket
- Spread the cost – just £29.99 every 6 issues by Direct Debit*
- FREE gift and FREE delivery every issue!

2 EASY WAYS TO SUBSCRIBE:

- 📞 ORDER ONLINE buysubscriptions.com/SCHLPTK
- 📞 CALL US NOW us on 03330 162 146+ (quote code SCHLPTK)

Hurry! Offer ends 15th May 2018!

*Call charges from mobile phones are included in free call packages. Outside of free call packages call charges from mobile phones will cost between 3p and 55p per minute. Calls from landlines will cost up to 9p per minute. Lines are open Mon to Fri 8am – 6pm and Sat 9am – 1pm. * This is an introductory offer for new UK print subscribers paying by Direct Debit only. Yarn pack and free home delivery is available to UK residents only. Your yarn pack will be despatched within 28 days of your order and is subject to availability whilst stocks last. The Hook 'n' Learn is a collectable series which runs across 13 issues. If you cancel your subscription before the Hook 'n' learn has finished you will not receive the Hook 'n' Learn patterns unless you purchase the magazine in-store. Immediate Media Company reserves the right to send an alternative product of the same or similar value. Your subscription will start with the next available issue.

JOIN THE FUN!



Prisoners at work in the oakum shed at Holloway Prison, London in 1862



The Knitter
FEATURE

Knitting behind bars

Penelope Hemingway examines the knitting that was carried out by convicts in 19th century prisons

VALUABLE EVIDENCE about the everyday knitting of the past comes from newspaper reports of stolen items, court cases about stolen goods, and accounts of prisoners and prison visits. In the 18th and 19th centuries, the theft of goods of the value of just a few shillings was a serious crime. A few convicts might get that commuted to transportation to Australia – but the theft of so little as a pair of stockings could be enough to hang someone. Such crimes, then, were well reported, and from newspaper accounts, clothing historians can get an idea of popular types of knitted items, and their colours, and how knitted goods were sold and distributed. For example:

“Tuesday Sir William Smith committed to Bridewell, one Ann Perkins, for going into a Shop, and pilfering thereout, a small Pair of Worsted Stockings, the Property of Mrs Nixon, at the Stocking Warehouse in Fleet Street.”

[‘REMEMBRANCER’, SEPTEMBER 29th, 1750]

From many descriptions of types of stockings, we learn they were classified as woollen (often called “yarn”) and worsted (smoothly spun); red, grey, and black; knitted in ribbing and stocking stitch.

Descriptions of runaway servants can be a rich source of information about knitted clothing:

“Eloped from his Master and Parents, a Youth about 16 Years of Age, tall and thin, of genteel Department, fair Complexion... he had on a Fawn-coloured Coat, and Waist-coat, with metal buttons Gilt, black Stocking Breeches, dark mixt Worsted ribbed Stockings, bad shoes on... Anyone finding him will be ‘genteelly rewarded’.”

[ST. JAMES’S CHRONICLE OR THE BRITISH EVENING POST, MAY 25th 1773 – MAY 27th 1773]

Accounts of crimes also give us information about contemporary dress, such as this example from *The Hull*

Packet newspaper, on July 24th, 1840: “... three men broke into the house by the kitchen window, and went to her room. They wore Guernsey frocks, knitted caps, the tassels of which hung over their shoulders, and had their faces disguised with sheep red...”

Sometimes, the perpetrators’ knitted clothing is described; sometimes, the victim is a knitter, which gives us the social context of knitting in the past:

“*The Partly Murdered Knitter*
“Sarah Campbell. – Was robbed and partly murdered that night (a laugh); was knitting at the fire, six or seven men came in; identifies Robert McClinchy as having been there; they picked witness’s pocket, and then tied and blindfolded her; they broke two of her ribs; robbed her of £3 and one shilling, a drab mantle, four handkerchiefs, and tied her to a post... several witnesses were produced to prove an alibi. – Guilty.”

[THE BELFAST NEWS-LETTER, AUGUST 5th, 1831] ▶

Knitting history



The 'pass-room' at London's Bridewell Prison, where single mothers were housed

Punishing the wicked

Knitting went on in jails; not so much as rehabilitation, but as punishment. There are newspaper articles about inmates' monotonous chores; like picking oakum, roadbreaking – or knitting. A journalist described visiting a “female prison”. He wrote:

“...stocking knitting...is carried on extensively during the hours when the prisoners are allowed to sit in the corridors, each at her own cell door, in silence for one term, and freely chatting through the second. Passing a file of stocking-knitters on my way out of the prison, I noticed a woman of about thirty standing at the end of the row... She was noticeable amongst the crowd because, whilst all the rest curtsied as the Lady Superintendent passed... she, after casting one sharp, angry glance at the approaching visitors, stood sullenly regarding the floor. ‘Who is that?’ I asked Mrs Gibson when we were out of sight and hearing. ‘That,’ said the Lady Superintendent, ‘is Constance Kent and a very hard subject she is to deal with. She is one of the few women in the prison whom I cannot ‘get at.’”

[DAILY NEWS, DECEMBER 30th, 1874]

No wonder Constance wasn't compliant: she is the subject of Kate Summerscale's novel *The Suspicions of Mr Whicher: or The Murder At Road Hill House* (Bloomsbury, 2008) and is now widely thought to have been innocent of the crime for which she was convicted.

Over on the criminal side of the jails, knitting was sometimes smuggled out, to provide an added income, on release. Prisoners were often given yarn, technically the property of the Governor, to knit items whilst behind bars.

In 1843, one enterprising inmate from Morpeth Jail, Ellen McGurch

(“a character well known to the turnkeys”) was found at release, to be wearing an undershift with stockings sewn to it and the hem doubled up. In the doubled-up hem were secreted many muffatees (knitted fingerless mitts). Apparently,

“...the female prisoners, instead of knitting the stockings with the yarn given to them, make muffatees and other articles... carry them out of the prison with them, and then dispose of them for money or drink...”

[THE NEWCASTLE JOURNAL, JANUARY 28th, 1843].

Many jails had two sides – one for ‘felons’ and one for debtors. Halifax landowner Anne Lister's diaries gave me my first inkling that debtor inmates knitted to make a little extra money. Anne wrote of a visit to York, on Thursday 18th October, 1821: “Went over the bridge at 11 ¼. Went shopping with my aunt... Walked with my aunt around the castle yard (she wanted some knitted nightcaps of the debtors)...” (as published in *The Secret Diaries of Miss Anne Lister*, (Virago, 2010, edited by Helena Whitbread).

In the 19th century, the York Castle jailer's journal recorded the location of burials of the executed prisoners; under the paving slabs of the prison yard. Anne and her aunt will have walked right over them to buy their night-caps.

One knitting prisoner in Lincoln, 61-year-old Jane Robinson, “who before her confinement in the Castle, lived at Atterby, is represented to have been a respectable and religious woman”, was buried inside the prison walls when she died. Her friends approached her creditor – the person who put her in prison – to ask him to release the body so she could be buried respectably. He refused. In the winter of 1831, one newspaper

described Jane's sudden death:

“God Visits

“On Thursday evening... Mrs Jane Robinson... had just taken tea, and appeared very happy and comfortable, when she observed to a woman who was with her, ‘As I have just got my knitting done, I will now read the Bible to you.’ Before she could fulfil her pious intention, she fell back in her chair, leaned her head against the wall of her cell, and died instantaneously. The coroner's inquest returned a verdict, ‘Died by the visitation of God, occasioned by the rupture of an internal blood-vessel.’”

[THE LINCOLN, RUTLAND AND STAMFORD MERCURY, NOVEMBER 11th, 1831]

Trials were held quarterly at the Assizes. During assizes, debtors sold their knitting to court attendees. In 1832, cholera swept the country. Lancaster Castle's high sheriff gave an order not to admit visitors to the debtors' side during the Assizes, to prevent the spread of disease. The prisoners were not allowed sell their knitting again, until the assizes were over. This gives us another brief, invaluable glimpse of the type of items knitted behind bars:

“...This was considered a great hardship by the debtors, as they had been accustomed to reap a pretty good harvest during the previous assizes, by the sale of articles of knitting, &c., such as purses, night-caps and other articles, which they manufacture during their imprisonment....”

[MANCHESTER TIMES, MARCH 31st, 1832]

– Read more about knitting history and research on Penelope Hemingway's blog, *The Knitting Genealogist*: www.theknittinggenie.com

Knitting history

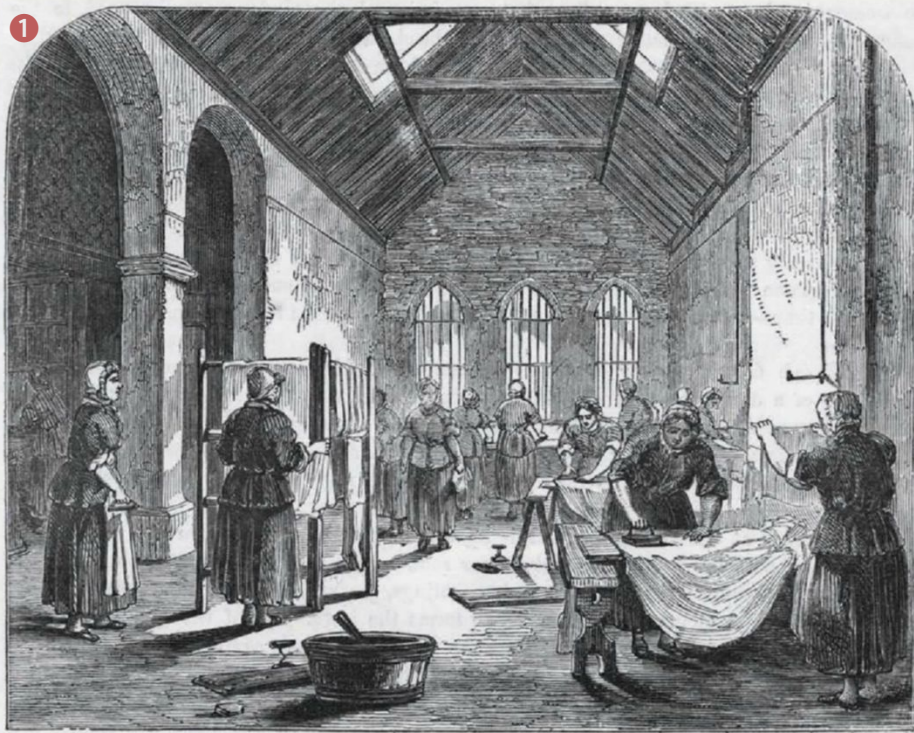

❶ Female prisoners at work in the ironing room of Brixton Prison, c. 1850
❷ Constance Kent was convicted of murdering her half-brother
❸ A woman sews sacks in a cell at Holloway Prison

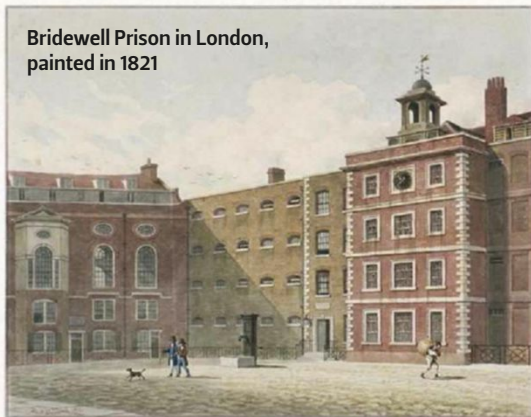

Bridewell Prison in London, painted in 1821

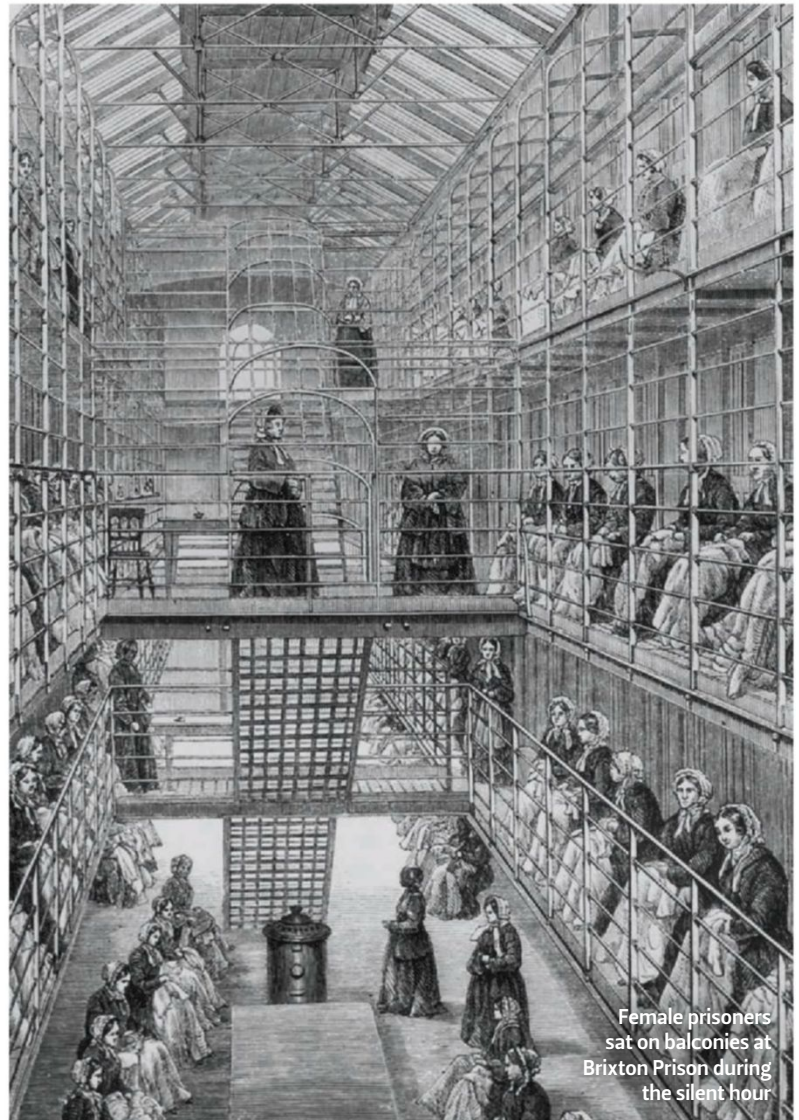
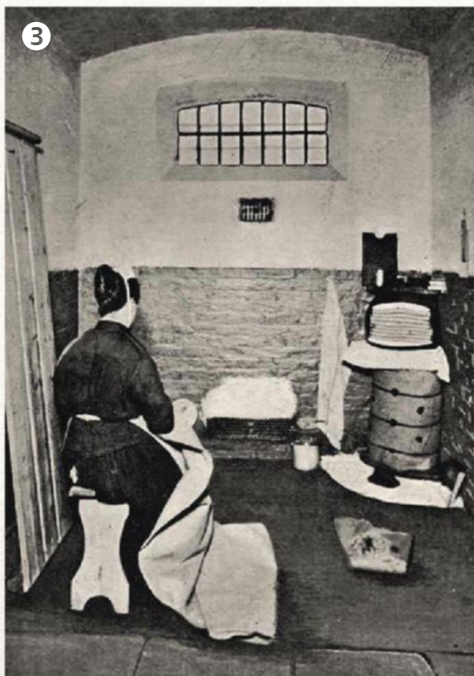

Female prisoners sat on balconies at Brixton Prison during the silent hour



Pat Menchini
Bellina

This colourful jumper for spring
has a lightweight, textured fabric

Bellina

A self-striping yarn
complements the
various stitch patterns





Pat Menchini
Bellina

AN ARRAY of stitch textures has been used on this lightweight jumper, including chevron lace, broken moss stitch, and eyelet diamond motifs. It has a semi-dolman shape, and a close fit. The sleeves are worked top down, so their length can be adjusted. It has been knitted in a self-stripping yarn from Scheepjes, called Secret Garden, which blends silk, cotton and polyester.

CHART

(written instructions)
(worked over 21 sts)

Row 1 (RS): K10, yo, skpo, K9.

Row 2 and every alt row: P21.

Row 3: K8, K2tog, yo, K1, yo, skpo, K8.

Row 5: K7, K2tog, yo, K3, yo, skpo, K7.

Row 7: K6, K2tog, yo, K2, yo, skpo, K1, yo, skpo, K6.

Row 9: K5, (K2tog, yo, K1) twice, yo, skpo, K1, yo, skpo, K5.

Row 11: K4, (K2tog, yo, K1) twice, K1, (K1, yo, skpo) twice, K4.

Row 13: K3, (K2tog, yo, K1) twice, K1, (yo, skpo, K1) twice, yo, skpo, K3.

Row 15: K2, (K2tog, yo, K1) 3 times, (yo, skpo, K1) twice, yo, skpo, K2.

Row 17: K1, (K2tog, yo, K1) 3 times, K1, (K1, yo, skpo) 3 times, K1.

Row 19: (K2tog, yo, K1) 3 times, K3, (K1, yo, skpo) 3 times.

Row 21: K2, (yo, skpo, K1) 3 times, (K2tog, yo, K1) 3 times, K1.

Row 23: K3, (yo, skpo, K1) twice, yo,

SIZE

	6-8	10-12	14-16	18-20	22-24	26-28	
TO FIT BUST	76-81	86-91	97-102	107-112	117-122	127-132	cm
	30-32	34-36	38-40	42-44	46-48	50-52	in
ACTUAL BUST	83	92	103	112	123	132	cm
	33	36¼	40½	44	48½	52	in
ACTUAL LENGTH	57	58	59	61	62	63	cm
	22½	23	23¾	24	24½	25	in
SLEEVE SEAM	41	41	41	41	41	41	cm
	16	16	16	16	16	16	in

YARN

Scheepjes Secret Garden (DK weight; 60% polyester, 20% silk, 20% cotton; 93m/102yds per 50g ball)

HERB GARDEN (702)	7	8	9	10	11	12	x50g BALLS

NEEDLES & ACCESSORIES

1 pair 3.25mm (UK 10/US 3) knitting needles
1 pair 4mm (UK 8/US 6) knitting needles
1 pair 4.5mm (UK 7/US 7) knitting needles
2 stitch holders
Stitch marker

TENSION

18 sts and 27 rows to 10cm over Main Patt using 4.5mm needles.
19 sts and 33 rows to 10cm over Chevron Pattern on 4mm needles.
Chart motif meas 9cm wide by 13cm tall.

Sl1, K2tog, pssso, yo, K1, (K2tog, yo, K1) twice, K2.

Row 25: K4, (yo, skpo, K1) twice, yo, skpo, (K2tog, yo, K1) twice, K3.

Row 27: K5, (yo, skpo, K1) twice, (K2tog, yo, K1) twice, K4.

Row 29: K6, yo, skpo, K1, yo, Sl1, K2tog, pssso, yo, K1, K2tog, yo, K6.

Row 31: K7, yo, skpo, K1, yo, skpo, K2tog, yo, K7.

Row 33: K8, yo, skpo, K1, K2tog, yo, K8.

Row 35: K9, yo, Sl1, K2tog, pssso, yo, K9.

Row 36: P21.

These 36 rows form panel.

BACK

Using 4mm needles, cast on 75 (83:93:101:111:119) sts.

Change to 3.25mm needles.

Purl 4 rows.

Change to 4mm needles.

Work in Chevron Pattern as follows:

Sizes 6-8, 14-16 and 22-24 only

Row 1 (RS): (K1, yo, skpo) to end.

Rows 2 and 4: Purl.

Row 3: K2, (yo, skpo, K1) to last st, K1.

Row 5: K3, (yo, skpo, K1) to end.

Row 6: Purl.

Rep these 6 patt rows 5 times more.

Reverse direction of chevrons:

Rows 1 (RS): K1, (K2tog, yo, K1) to last 2 sts, K2.

Rows 2 and 4: Purl.

Row 3: (K2tog, yo, K1) to end.

Row 5: K2, (K2tog, yo, K1) to last st, K1.

Row 6: Purl.

Rep these 6 patt rows 5 times more.

Sizes 10-12, 18-20 and 26-28 only

Row 1 (RS): (K1, yo, skpo) to last 2 sts, K2.

Rows 2 and 4: Purl.

Row 3: K2, (yo, skpo, K1) to end.

Row 5: K3, (yo, skpo, K1) to last 2 sts, yo, skpo.

Row 6: Purl.

Rep these 6 patt rows 5 times more.

Reverse direction of chevrons:

Row 1 (RS): K1, (K2tog, yo, K1) to last st, K1.

Rows 2 and 4: Purl.

Row 3: (K2tog, yo, K1) to last 2 sts, K2.

Row 5: K2, (K2tog, yo, K1) to end.

Row 6: Purl.

Rep these 6 patt rows 5 times more.

All sizes

Change to 4.5mm needles.

Work 2 rows in st st, beg with a K row.

Work in Main Pattern as follows:

Row 1 (RS): K1, (P1, K1) to end.

Row 2: Purl.

Row 3: K2, (P1, K1) to last st, K1.

Row 4: Purl.

These 4 rows set Main Pattern.

Cont in Main Pattern until work meas 32cm from beg, measured through centre of

BLOCKING DIAGRAM

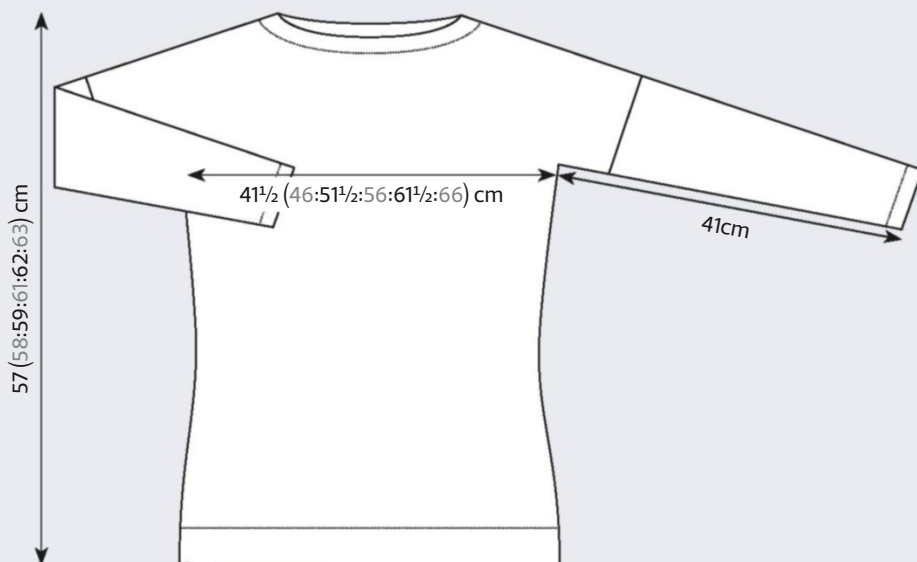

YARN STOCKISTS

Scheepjes www.scheepjes.com/en

Available in the UK from:

Wool Warehouse 01926 882818

www.woolwarehouse.co.uk

Deramores www.deramores.com

Black Sheep Wools 01925 764231

www.blacksheepwools.com

For general abbreviations, see p81

KEY

□ K on RS; P on WS

▤ K2tog

▥ Skpo

○ Yo

▧ Sk2po

CHART

Chart

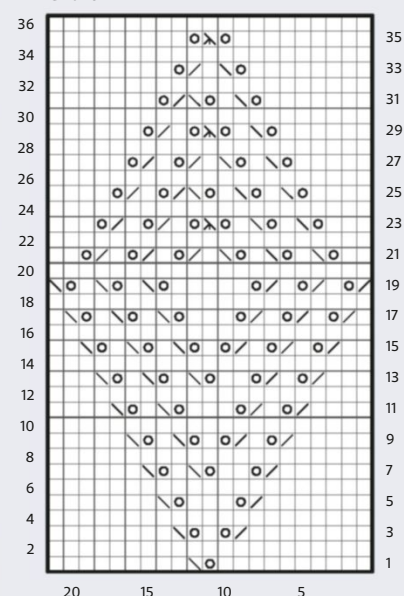

Chevron stitch makes an impact on the lower half

work and ending after a P row.

SHAPE SLEEVES

Working extra sts into patt, inc 1 st at each end of next row, then on the 3 foll alt rows. 83 (91:101:109:119:127) sts.

Work 1 row straight.

Inc 1 st at each end of next 6 rows.

95 (103:113:121:131:139) sts.

Finally cast on 7 (8:8:9:9:10) sts at beg of next 2 rows, then 7 sts at beg of foll 2 rows. 123 (133:143:153:163:173) sts.

Place a marker at centre of last row.

Work straight until Back meas 13 (14:15:17:

18:19) cm from marker, ending after a P row.

SHAPE SHOULDERS

Cast off loosely 5 (6:6:7:7:8) sts at beg of next 14 rows, then 10 (7:11:8:12:9) sts at beg of next 2 rows.

Slip rem 33 (35:37:39:41:43) sts on a stitch holder and leave.

FRONT

Work as Back until Front meas 8 (9:10:11:12:13) cm from marker, ending after a P row.

SHAPE NECK

Next row: Patt 50 (54:58:62:66:70), turn.

Cont on this group of sts for left half of neck.

Dec 1 st at neck edge on next 5 rows, thus ending at sleeve edge.

45 (49:53:57:61:65) sts

Cont straight until Front meas same as Back to shoulder shaping, ending at sleeve edge.

SHAPE SHOULDER

Cast off loosely 5 (6:6:7:7:8) sts at beg of next row and the 6 foll alt rows.

Work 1 row straight.

Cast off rem 10 (7:11:8:12:9) sts.

With RS facing, slip next 23 (25:27:29:31:33) sts onto a stitch holder. ▶



The jumper has a semi-dolman shape, with lace details on the sleeves

With RS facing, rejoin yarn to rem 50 (54:58:62:66:70) sts and patt to end of row.

Dec 1 st at neck edge on next 5 rows.

Work 1 row straight, thus ending at sleeve edge. 45 (49:53:57:61:65) sts

Shape shoulder as left side of neck.

SLEEVES

(worked top down)

Using 4mm needles, cast on

51 (55:61:65:71:75) sts.

Beg with a K row, work 2 rows in st st.

Cont in st st and place centre panel:

Row 1 (RS): K15 (17:20:22:25:27), work 21 sts from row 1 of Chart, K15 (17:20:22:25:27).

Row 2: P15 (17:20:22:25:27), work 21 sts from row 2 of Chart, P15 (17:20:22:25:27).

Rows 3–8: Rep rows 1–2, three more times but working rows 3–8 of Chart.

Note: read ahead, Sleeve shaping is worked AT THE SAME TIME as chart placement.

Continue to work through to Row 36 of Chart twice, then work Rows 1 and 2 once more, then continue in st st, AT THE SAME TIME dec 1 st each end of next row and every following 10th row to 43 (45:47:51:57:61) sts, then every 10th (8th:6th:6th:4th:4th) row until 35 (37:39:39:41:43) sts rem.

Work straight until Sleeve meas 40cm from beg, measured through centre of work, ending after a K row. Length may be adjusted here.

Change to 3.25mm needles.

Knit 4 rows.

Cast off loosely knitwise.

NECKBAND

Join left shoulder.

Using 3.25mm needles, with RS facing, knit across 33 (35:37:39:41:43) sts on stitch holder, pick up and K23 (23:23:25:25:25) sts evenly down left side of front neck, knit across 23 (25:27:29:31:33) sts on stitch holder, finally pick up and K23 (23:23:25:25:25) sts evenly up right side of neck. 102 (106:110:118:122:126) sts.

Knit 4 rows.

Cast off evenly knitwise.

TO MAKE UP

Join right shoulder and edges of neckband. Stitch cast-on edges of sleeves to edges of back and front yoke.

Join side and sleeve seams. ☸

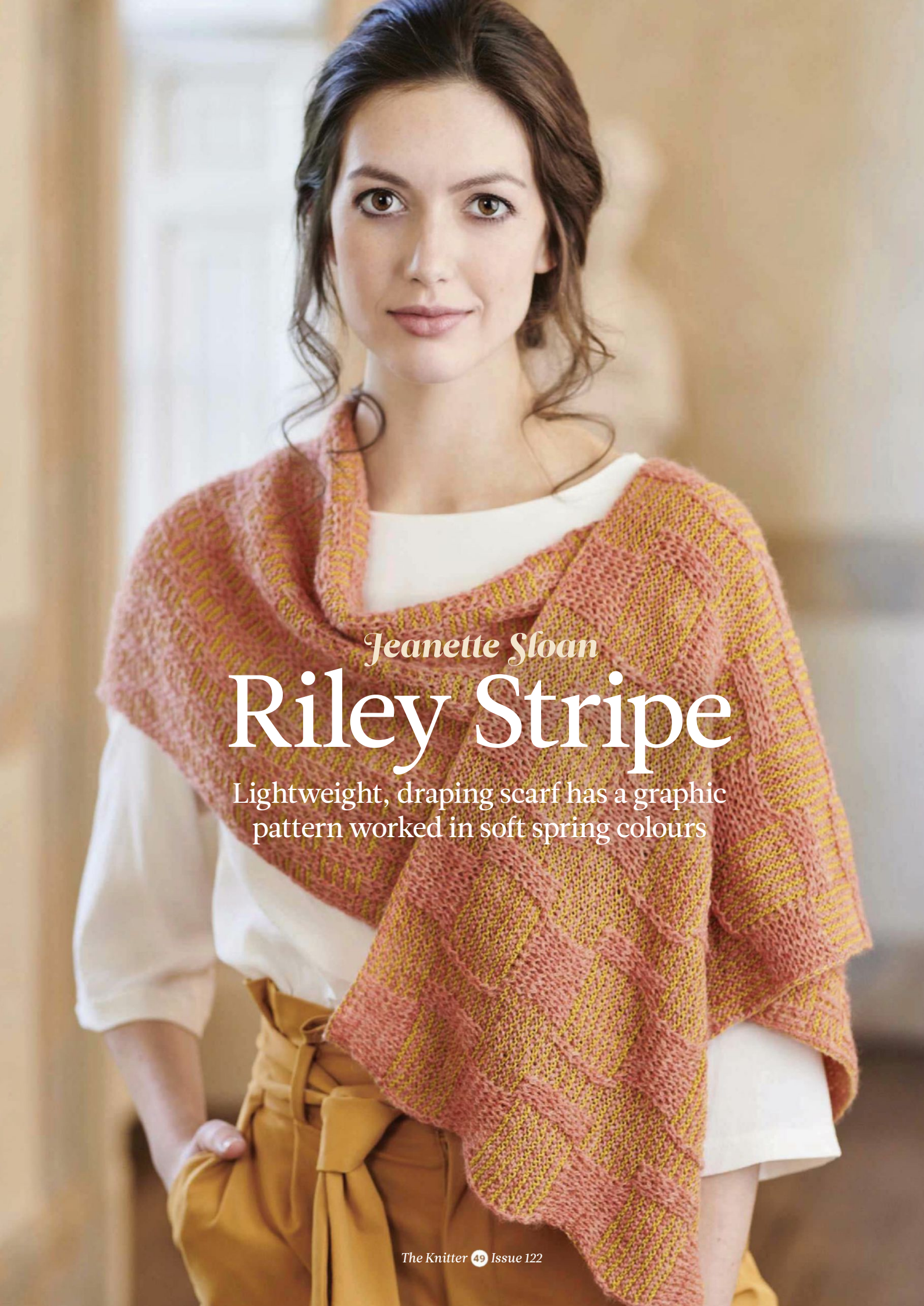

Jeanette Sloan

Riley Stripe

Lightweight, draping scarf has a graphic pattern worked in soft spring colours



Jeanette Sloan Riley Stripe

INSPIRED BY the abstract, dynamic art of Bridget Riley, Jeanette Sloan has created this attractive scarf. It features two distinct slip stitch patterns, worked in contrasting shades of pink and yellow. The first section is worked then cast off, before stitches are picked up along the short edge to work the second patterned section. Jeanette has knitted her scarf using two yarns from Isager – a pure lambswool, and a linen-viscose blend; the contrast in textures helps to highlight the slip stitch patterning.

PATTERN NOTES

All stitches are slipped purlwise, with the yarn held at the back on RS rows, and with the yarn held at the front on WS rows. Because the side edges of the scarf will be visible when it's worn, it is important to

SIZE

182cm x 35cm (71½in x 13¾in)

YARN

Isager Highland Wool (3ply/light fingering weight; 100% lambswool; 275m/301yds per 50g ball)

Rhubarb; 3 x 50g balls

Isager Viscolin (4ply weight; 50% linen, 50% viscose; 185m/202yds per 50g ball)
Shade 40; 3 x 50g balls

NEEDLES & ACCESSORIES

1 pair 3.5mm knitting needles

TENSION

28.5 sts and 52 rows to 10cm over slip and garter stitch stripe from Chart A on 3.5mm needles.

26.5 sts and 52.5 rows to 10cm over slip and garter stitch stripe from Chart B on 3.5mm needles.

YARN STOCKISTS

Isager www.isagerstrik.dk
c/o Oxford Yarn Store 01865 604112
www.oxfordyarnstore.co.uk

For general abbreviations, see p81

take care to twist the yarns neatly up the side of the work as you knit, and you should avoid joining in new balls or yarn in the middle of a row.

The scarf is knitted in two sections using contrasting stitch patterns that are given in chart form. The first section begins with a two-colour cast-on, and finishes with a two-colour cast-off.

The stitches for the main section are picked up and worked off the straight side of the first piece, and also finish with a two-colour cast-off edge with slip stitch edges, giving the scarf a defined border at each long side.

If you find it hard to control the tension of the two-colour cast-off, try using a needle one or two sizes larger.

SCARF

Using 3.5mm needles and one end of each colour held together, make a slip knot and place it on the needle. Then threading one yarn over the thumb and the other over the index finger of your preferred hand in the slingshot position, use the two-colour method to cast on 173 sts. (This tutorial is for double knitting, but the technique is the same: <http://bit.ly/2colltco>)

From this point you'll be using only one colour at a time, starting with yarn A and working two rows in each colour. As you alternate the colours, take care to twist the yarns neatly up the side of the work.

Begin Chart A, working 3 repeats of the 52-row chart, then work Rows 1-26 once more.

Cast off in two colours.

MAIN SECTION

Now with the RS of the first section facing and using yarn B, pick up and knit 93 sts evenly across the straight edge of the piece, but avoid working into the slip stitch edge worked in yarn A.

Next row: Knit.

Using yarn A and alternating colours as before, begin Chart B, working the 8-st pattern 11 times.

Having established placement of the pattern, continue working from chart alternating colours as before until 20 repeats of the chart have been completed, then repeat Rows 1 and 2 once more.

Cast off in two colours.

FINISHING

Weave in all ends. Carefully pin the scarf to given measurements and steam gently, following any yarn care instructions on the ball band. ☺

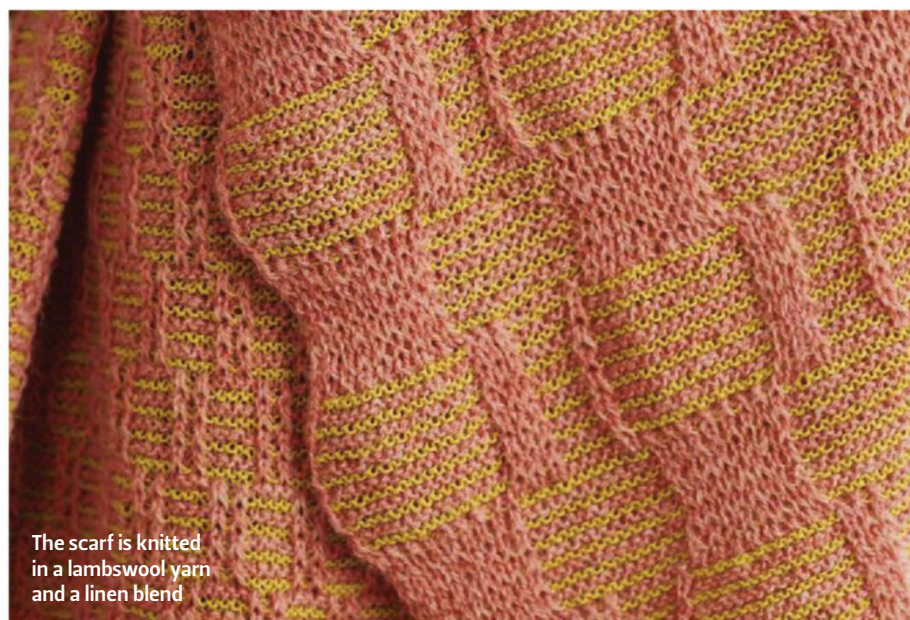

The scarf is knitted in a lambswool yarn and a linen blend

CHARTS

Chart A

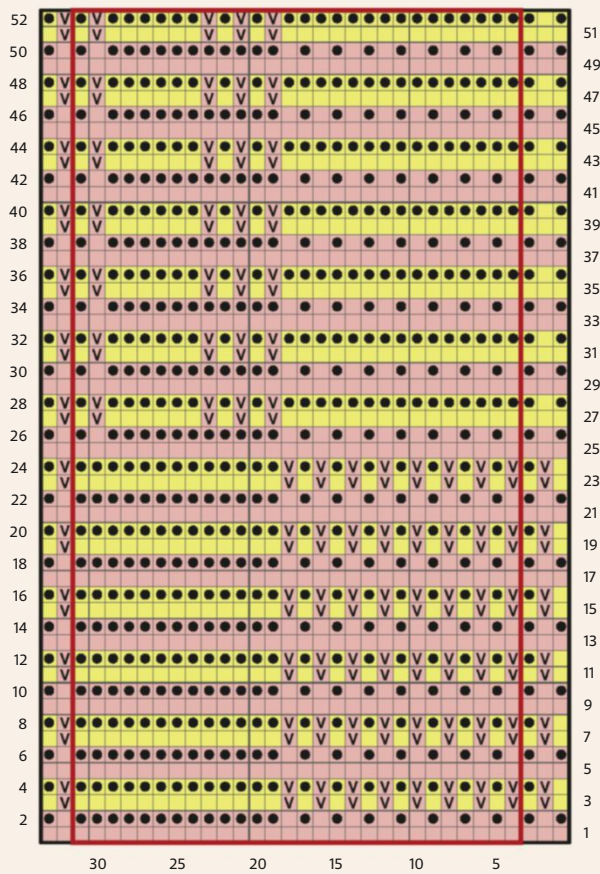
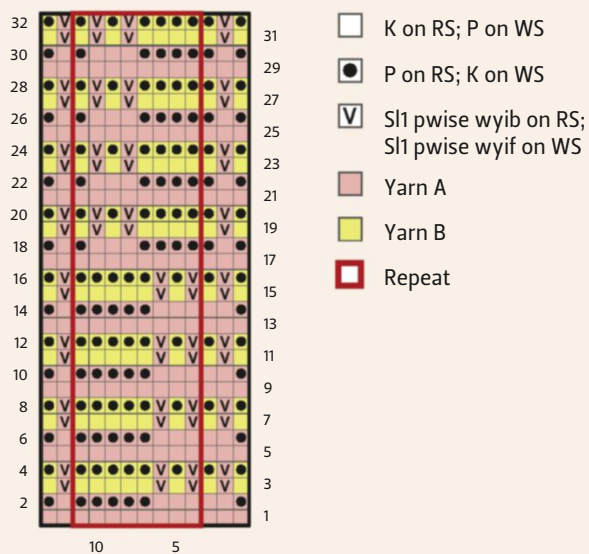

Chart B



KEY

- K on RS; P on WS
- P on RS; K on WS
- V SL1 pwise wyib on RS;
SL1 pwise wyif on WS
- Yarn A
- Yarn B
- Repeat

The two sections have contrasting stitch patterns



“ THE CONTRASTING YARN TEXTURES HELP TO EMPHASISE THE SLIP STITCH PATTERNS ”

Knitting in the Faroe Islands

WITH KATRINA I GEIL

13th August or 25th June 2018 - 7 nights from £1895

Join us for this wonderful opportunity to discover the stunning landscapes of the Faroe Islands in the company of fellow travellers who share your passion for knitting! Enjoy two and a half days of private workshops where, under the guidance of local knitting expert Katrina i Geil, you'll learn about the Faroese knitting traditions as you create your own Faroese inspired project. Your hotel is close to the harbour in the centre of Torshavn, the charming capital of the Faroes and at the heart of this island community.

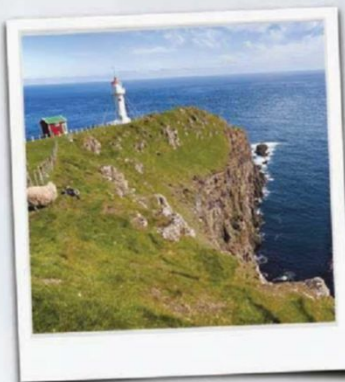

WHAT'S INCLUDED?

- Return flights between Edinburgh and Vágar Airport (Faroe Islands)
- 7 nights hotel accommodation at the Hotel Hafnia on a bed and breakfast basis
- Welcome dinner and Farewell dinner in the hotel.
- 5 x Half Day workshops led by a local knitting expert
- Guided tour of Torshavn and visit to a local textile designer
- Full day sightseeing of the stunning Faroe Islands
- Coach Transfers throughout
- Visit to the Art and National Museum

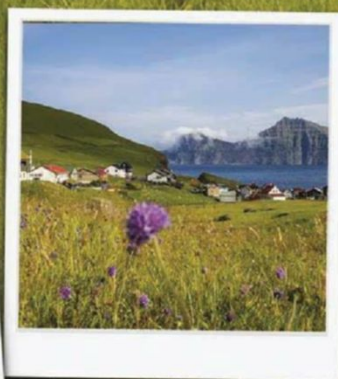
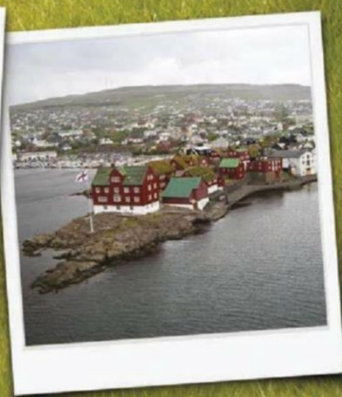

With both included excursions and a choice of optional tours, you can delve deep and explore the stunning landscapes and extraordinary nature of this remote north Atlantic outpost.

Find out more at stichtopia.co.uk or call 01473 633 506 and quote IMM18

The
Knitter
Reader
Offer

ARENA
T R A V E L
Passionate about your passions



ABTA
Travel with confidence
ABTA No. Y6426

Stichtopia

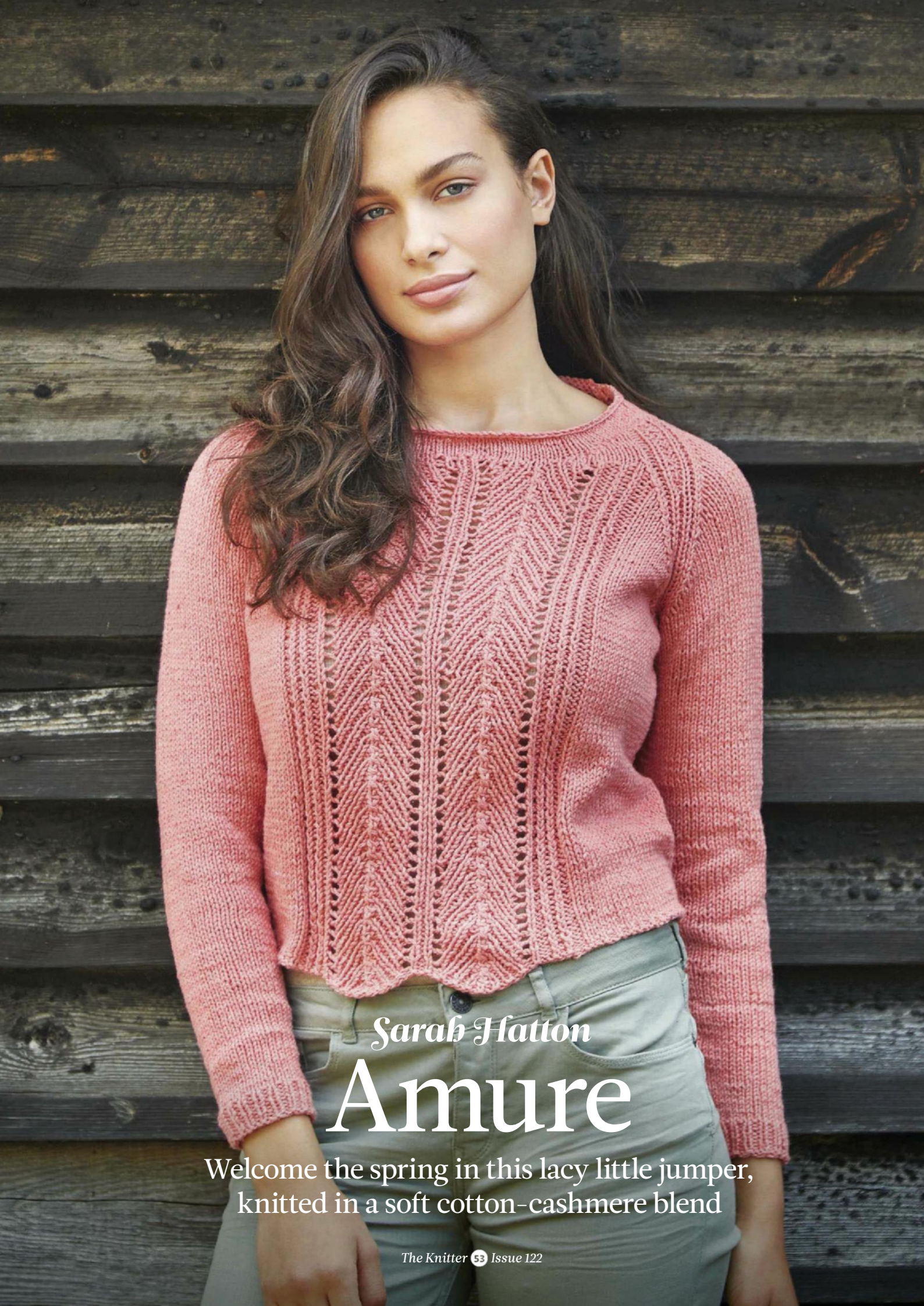

Sarah Hatton

Amure

Welcome the spring in this lacy little jumper,
knitted in a soft cotton-cashmere blend



Sarah Hatton
Amure

DESIGNED BY Sarah Hatton, this cropped raglan jumper has a beautiful spring feel. It's adorned with a lace panel, and has three-quarter-length sleeves and a simple rolled neck edge. It has been knitted in Rowan's new yarn, Cotton Cashmere. This is a lovely DK-weight blend which gives a smooth fabric, and comes in 16 delicate shades.

BACK

Using 3.25mm needles, cast on 105 (115:125:135:145) sts.

Row 1 (RS): K1, *P1, K1, rep from * to end.

Row 2: P1, *K1, P1, rep from * to last 2 sts, K2tog.

104 (114:124:134:144) sts.

Change to 4mm needles.

Beg with a K row, work in st st until Back meas 27 (27½:28:28½:29) cm, ending with RS facing for next row.

SHAPE RAGLAN ARMHOLES

Cast off 5 sts at beg of next 2 rows.

94 (104:114:124:134) sts.

Next row (RS): (K1, P1) twice, skpo, K to last 6 sts, K2tog, (P1, K1) twice.

Next row: (P1, K1) twice, P2tog, P to last 6 sts, P2tog tbl, (K1, P1) twice.

Rep last 2 rows 8 (11:13:16:18) times more. 58 (56:58:56:58) sts.

Next row (RS): (K1, P1) twice, skpo, K to

SIZE

	8-10	12-14	16-18	20-22	24-26	
TO FIT BUST	81-86	91-97	102-107	112-117	122-127	cm
	32-34	36-38	40-42	44-46	48-50	in
	104	114	124	134	144	cm
ACTUAL BUST	41	45	49	53	57	in
	45½	47½	49½	51½	53½	cm
ACTUAL LENGTH	18	18½	19½	20½	21	in
	44	44	45	45	45	cm
SLEEVE SEAM	17½	17½	17½	17½	17½	in

YARN

Rowan Cotton Cashmere (DK weight; 85% cotton, 15% cashmere; 125m/137yds per 50g ball)

CORAL SPICE 214	7	7	8	9	10	x50g BALLS
-----------------	---	---	---	---	----	------------

NEEDLES & ACCESSORIES

1 pair 3.25mm (UK 10/US 3) knitting needles
1 pair 4mm (UK 8/US 6) knitting needles
Stitch holders

TENSION

20 sts and 28 rows to 10cm over st st on 4mm needles. Pattern panel (49 sts) meas 20.5cm.

YARN STOCKISTS

Rowan 01484 950630
www.knitrowan.com

For general abbreviations, see p81

last 6 sts, K2tog, (P1, K1) twice.

Next row: (P1, K1) twice, P to last 4 sts, (K1, P1) twice.

Rep last 2 rows 15 (14:14:13:13) times more, ending with RS facing for next row.

Leave rem 26 (26:28:28:30) sts on a holder.

FRONT

Using 3.25mm needles, cast on 115 (123:135:143:155) sts.

Row 1 (RS): (K1, P1) 16 (18:21:23:26) times, K1, P2, K1 tbl, P1, K1 tbl, P2, (K1, P1) 17 times, K1, P2, K1 tbl, P1, K1 tbl, P2, K1, (P1, K1) 16 (18:21:23:26) times.

Row 2: (K2tog) 1 (0:1:0:1) times, (P1, K1) 15 (18:20:23:25) times, P1, K2, P1, K1, P1, K2, (P1, K1) 17 times, P1, K2, P1, K1, P1, K2, P1, (K1, P1) 15 (18:20:23:25) times, (K2tog) 1 (0:1:0:1) times.

113 (123:133:143:153) sts.

Change to 4mm needles.

Now work in pattern as follows:

Row 1 (RS): K32 (37:42:47:52), P2, K1 tbl, P1, K1 tbl, P2, K1, yo, (P1, K1) 3 times, s2kpo, (K1, P1) 3 times, yo, K1, P1, K1, yo, (P1, K1) 3 times, s2kpo, (K1, P1) 3 times, yo, K1, P2, K1 tbl, P1, K1 tbl, P2, K32 (37:42:47:52).

Row 2: P32 (37:42:47:52), K2, P1, K1, P1, K2, P2, (K1, P1) 3 times, P1, (P1, K1) 3 times, P2, K1, P2, (K1, P1) 3 times, P1, (P1, K1) 3 times, P2, K2, P1, K1, P1, K2, P32 (37:42:47:52).

Row 3: K32 (37:42:47:52), P2, K1 tbl, P1, K1 tbl, P2, K1, yo, (K1, P1) 3 times, s2kpo, (P1, K1) 3 times, yo, K1, P1, K1, yo, (K1, P1) 3 times, s2kpo, (P1, K1) 3 times, yo, K1, P2,

K1 tbl, P1, K1 tbl, P2, K32 (37:42:47:52).

Row 4: P32 (37:42:47:52), K2, P1, K1, P1, K2, (P1, K1) 17 times, P1, K2, P1, K1, P1, K2, P32 (37:42:47:52).

These 4 rows form pattern.

Cont in pattern until Front meas same as Back to beg of raglan armhole shaping, ending with RS facing for next row.

SHAPE RAGLAN ARMHOLES

Keeping patt correct, cast off 5 sts at beg of next 2 rows.

103 (113:123:133:143) sts.

Next row (RS): (K1, P1) twice, skpo, patt to last 6 sts, K2tog, (P1, K1) twice.

Next row: (P1, K1) twice, P2tog, patt to last 6 sts, P2tog tbl, (K1, P1) twice.

Rep last 2 rows 8 (11:13:16:18) times more. 67 (65:67:65:67) sts.

Next row (RS): (K1, P1) twice, skpo, patt to last 6 sts, K2tog, (P1, K1) twice.

Next row: (P1, K1) twice, patt to last 4 sts, (K1, P1) twice.

Rep last 2 rows 6 (5:4:3:2) times more, ending with RS facing for next row. 53 (53:57:57:61) sts.

SHAPE NECK

Next row (RS): (K1, P1) twice, skpo, K9 (9:11:11:13), turn and leave rem sts on a holder.

14 (14:16:16:18) sts.

Work each side of neck separately.

Dec 1 st at neck edge of next 4 rows, then on

BLOCKING DIAGRAM

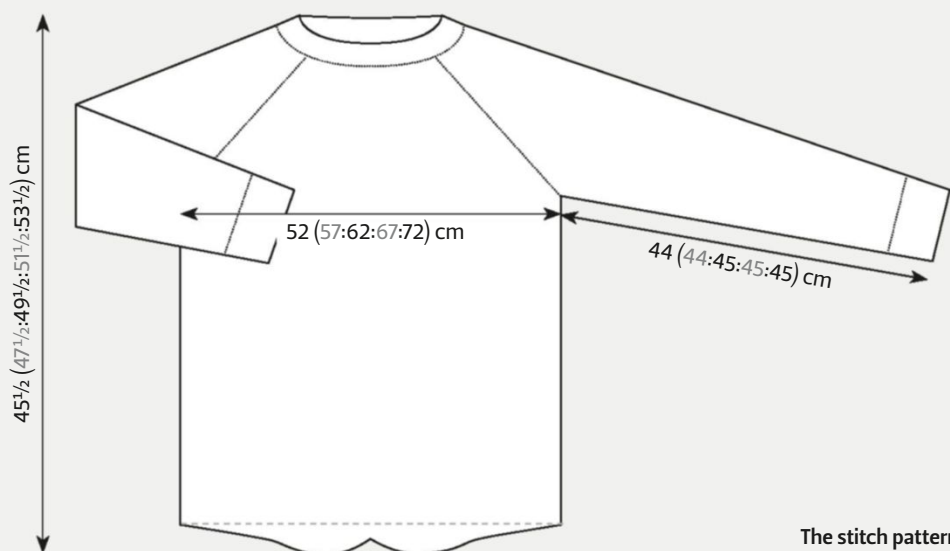

The stitch pattern forms a shaped edge on the centre front



1 (1:2:2:3) foll alt rows, AT THE SAME TIME dec 1 st at raglan edge in 2nd and every foll alt row. 6 sts.

Work 1 row, ending with RS facing for next row.

Next row (RS): K1, P1, K1, sk2po. 4 sts.

Next row: (K1, P1) twice.

Next row: K1, sk2po. 2 sts.

Next row: P2.

Next row: K2tog.

Fasten off.

With RS facing, slip centre 23 sts onto a holder, rejoin yarn to rem sts, patt to last 6 sts, K2tog, (P1, K1) twice. 14 (14:16:16:18) sts.

Complete to match first side, reversing shapings and working last 5 rows as folls:

Next row (RS): K3tog, K1, P1, K1. 4 sts.

Next row: (P1, K1) twice.

Next row: K3tog, K1. 2 sts.

Next row: P2.

Next row: K2tog.

Fasten off.

SLEEVES

Using 3.25mm needles, cast on 37 (39:41:41:43) sts.

Work 8 rows in rib as given for Back, dec 1 st at end of last row, and ending with RS facing for next row.

36 (38:40:40:42) sts.

Change to 4mm needles.

Beg with a K row, work in st st, inc 1 st at

each end of 5th row, then on every foll 6th (6th:4th:4th:4th) row until there are 58 (68:52:64:72) sts, then on every foll 8th (8th:6th:6th:6th) row until there are 68 (72:80:84:88) sts.

Cont straight until Sleeve meas 44 (44:45:45:45) cm, ending with RS facing for next row.

SHAPE RAGLAN

Cast off 5 sts at beg of next 2 rows.

58 (62:70:74:78) sts.

Working all decs as set by Back, dec 1 st at each end of next 1 (1:5:5:5) rows, then on every foll alt row until 14 sts rem.

Work 1 row, ending with RS facing for next row.

LEFT SLEEVE

Dec 1 st at beg of next row and cast off 4 sts at beg of foll row. 9 sts.

RIGHT SLEEVE

Cast off 4 sts at beg and dec 1 st at end of next row. 9 sts.

Work 1 row, ending with RS facing for next row.

BOTH SLEEVES

Rep last 2 rows once more. 4 sts.

Next row (RS): (K2tog) twice. 2 sts.

Next row: P2.

Next row: K2tog.

Fasten off.

MAKING UP

Block pieces carefully, following any yarn care instructions on the ball band. Join both front and right back raglan seams using back stitch, or mattress stitch if preferred.

NECKBAND

With RS facing and using 3.25mm needles, pick up and knit 13 sts from top of left sleeve, 11 (11:13:13:15) sts down left side of neck, knit across 23 sts from front holder, pick up and knit 11 (11:13:13:15) sts up right side of neck, 13 sts from top of right sleeve and knit across 26 (26:28:28:30) sts from back holder.

97 (97:103:103:109) sts.

Beg with a P row, work 7 rows in st st, ending with RS facing for next row.

Cast off knitwise.

Sew left back raglan and neckband seam. Sew sleeve and side seams.

Weave in ends. ☺



This design also appears in Rowan's new pattern book, *Cotton Cashmere*,

which has 11 garments and accessory patterns for women by Sarah Hatton. For stockist details, call **01484 950630** or visit **www.knitrowan.com**.

Amure

The cotton-cashmere
yarn gives a soft,
smooth fabric with
good stitch definition



BRAND
NEW

TRY 5 ISSUES FOR JUST £5

when you subscribe today

wellbeing



SELF-CARE, RELAXATION
& HAPPINESS

living



FOOD, FAMILY
& FRIENDS

creating



MINDFULNESS
THROUGH MAKING

escaping

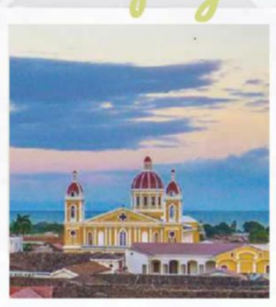

TRAVEL & ADVENTURE
FOR BODY & SOUL



2 easy ways to subscribe

CALL NOW on 03330 162 153* (quote code 'ITHA18')
ORDER ONLINE at www.buysubscriptions.com/ITHA18

*Calls from landlines will cost up to 9p per minute. Call charges from mobile phones will cost between 3p and 55p per minute but are included in free call packages. Lines are open 8am - 8pm weekdays and 9am-1pm Saturdays. Overseas readers call +44 1604 828 742. This offer ends 31st December 2018. 5 for £5 offer is available for UK residents paying by Direct Debit only. If you cancel within two weeks of receiving your fourth issue you will pay no more than £5. Otherwise your subscription will continue at £29.49 every 6 issues, saving 18%. Your subscription will start with the next available issue and you will receive 13 issues in a year. Full details of the Direct Debit guarantee are available upon request. Prices correct at point of print and subject to change.

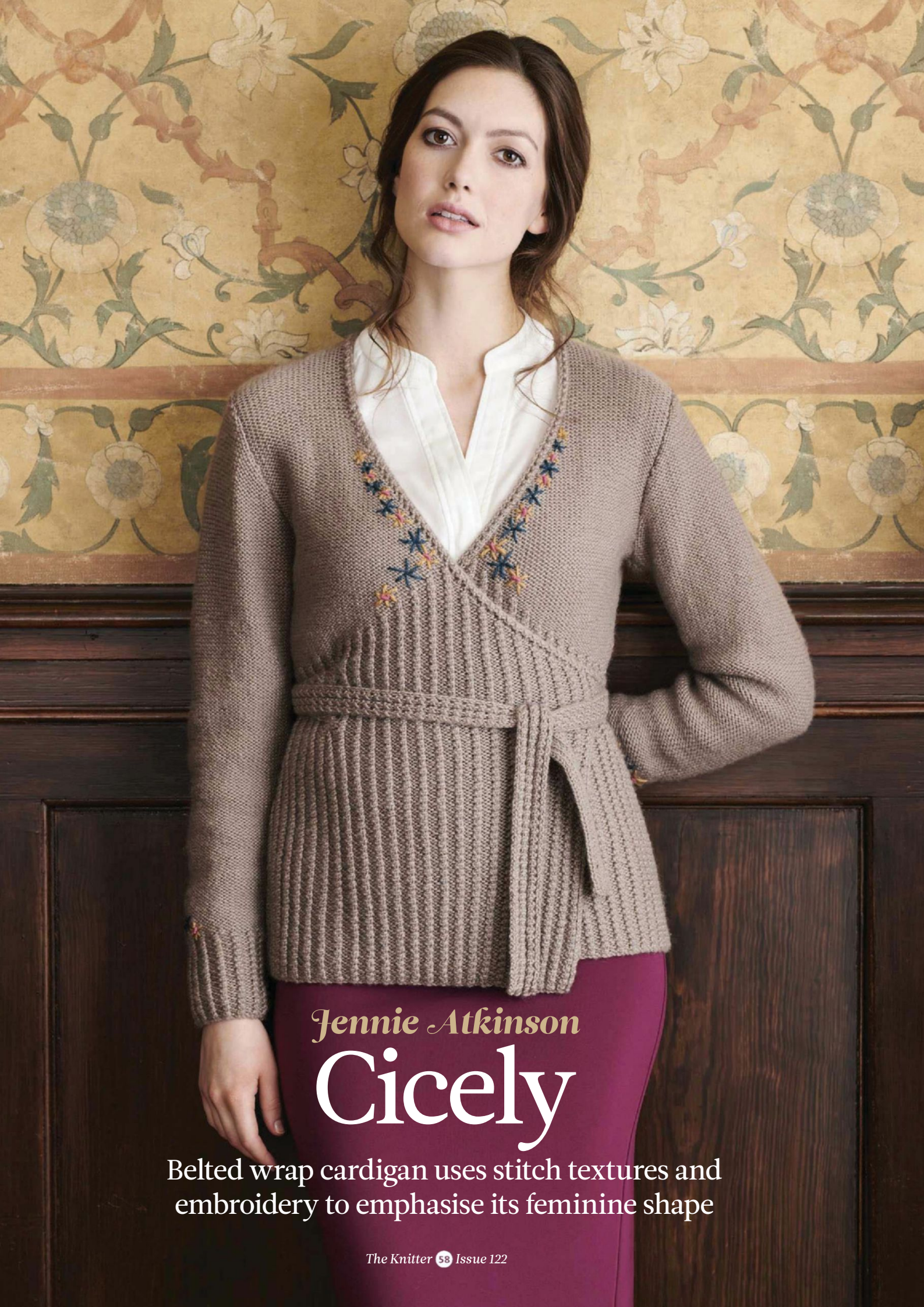

Jennie Atkinson

Cicely

Belted wrap cardigan uses stitch textures and embroidery to emphasise its feminine shape

Cicely



Lower part of the cardigan uses a knotted rib stitch



Jennie Atkinson
Cicely

JENNIE ATKINSON is known for her vintage-inspired designs, and this wrap cardigan has a 1920s feel. The upper body and sleeves are knitted in reverse stocking stitch, while the lower body uses a knotted rib pattern, which emphasises the shaping of the garment; simple embroidery adds a pretty finishing touch. The project is knitted in Erika Knight's British Blue 100 yarn, which is a lustrous Bluefaced Leicester wool grown and spun in Britain. It comes in eight sophisticated colours.

PATTERN NOTES

Stitch count changes between rows in the Knotted Rib pattern. Work partial repeats in K1, P2 rib, making sure pattern ends with a repeat of 3 sts before any shaping. All stitch counts given apply only after WS rows (when stitch pattern is a multiple of 3).

STITCH PATTERNS

KNOTTED RIB

(multiple of 3-4 sts + 2)

Row 1 (RS): P2, *KFB, P2; rep from * to end.

Row 2 (WS): K2, *P2tog, K2; rep from * to end.

Rep these 2 rows for pattern, ending after Row 2.

BACK

Using 3.75mm needles, cast on 98 (104:110:116:122:128:131:137:143) sts.

SIZE

	8	10	12	14	16	18	20	22	24	
TO FIT BUST	81½	86½	91½	96½	101½	106½	112	117	122	cm
	32	34	36	38	40	42	44	46	48	in
BACK BUST WIDTH	43	45½	48½	51½	54	56½	58½	61	63½	cm
	17	18	19	20¼	21¼	22¼	23	24	25	in
ACTUAL LENGTH	61	61½	62	64	65	65½	66½	67½	69	cm
	24	24¼	24½	25¼	25½	25¾	26¼	26½	27¼	in
SLEEVE SEAM	48	48	48	48	48	48	48	48	48	cm
	19	19	19	19	19	19	19	19	19	in

YARN

Erika Knight British Blue 100 (DK weight; 100% wool; 220m/240yds per 100g skein)

CLARISSA (600)	6	6	7	7	8	8	9	9	10	x100g SKEINS

Plus small amounts of Regents Park (602), Ballet Russes (606), and Mrs Dalloway (604), for the embroidery

Work 4 rows in Knotted Rib.

Change to 4mm needles.
Cont in Knotted Rib until work meas 10cm, ending after a WS row.

Cont in patt, dec 1 st at each end of next row, then every foll 6th row 3 more times, then every foll 4th row 5 times.
80 (86:92:98:104:110:113:119:125) sts.

Work even in patt for 17 (17:17:21:21:23:23:27) rows.

Next row (RS): Purl, inc 6 sts evenly across row.
86 (92:98:104:110:116:119:125:131) sts.

Beg with a knit (WS) row, work in reverse st st, inc 1 st at each end of every foll 6th row 4 times.
94 (100:106:112:118:124:127:133:139) sts.
Work even in patt without shaping until work meas 40 (40:40:41:41:41:42:42:43) cm from cast-on, ending after a WS row.

SHAPE ARMHOLES

Cont in patt, cast off 4 (4:5:6:6:7:7:8:9) sts at beg of next 2 rows.
86 (92:96:100:106:110:113:117:121) sts.
Keeping in patt, dec 1 st at each end of every row 1 (3:3:3:3:3:5:5) times, then every foll alt row 2 (2:3:4:6:7:6:8:9) times.
80 (82:84:86:88:90:91:91:93) sts.
Work even in patt until armhole meas 19 (20:20½:21:21½:22:23:23½:24) cm,

ending after a WS row.

SHAPE RIGHT BACK SHOULDER AND NECK

Next row (RS): P25 (25:25:26:26:27:27:27:28), turn. Leave rem sts of row on holder.
Next row (WS): SSK, K16 (16:16:16:16:18:18:18:18), turn.
Next row: P to last 2 sts, P2tog.
Next row: K2tog, K7 (7:7:7:7:8:8:8:8), turn.
Next row: P8 (8:8:8:8:9:9:9:9).
Break yarn and leave sts on holder.

SHAPE LEFT BACK SHOULDER AND NECK

With RS facing, join yarn to rem sts of back and cast off 30 (32:34:34:36:36:37:37:37) sts. Cont as for Right Back shoulder and neck, reversing shapings.

LEFT FRONT

Using 3.75mm needles, cast on 74 (77:80:83:86:89:92:98:101) sts.
Work 4 rows in Knotted Rib.

Change to 4mm needles.
Cont in Knotted Rib until work meas 10cm, ending after a WS row.
Keeping patt correct, dec 1 st at beg of next row, then every foll 6th row 3 more times, then every foll 4th row 5 times.
65 (68:71:74:77:80:83:89:92) sts.
Work even in patt for 17 (17:17:21:21:19:21:21:25) rows.

Note: Remember to work partial repeats of Knotted Rib pattern in K2, P1 rib. Work neck decreases into rib pattern.

Row 1 (RS): PFB, P3 (3:3:4:4:4:5:5:5), pm,

NEEDLES & ACCESSORIES

1 pair 4mm (UK 8/US 6) knitting needles
 1 pair 3.75mm (UK 9/US 5) knitting needles
 Stitch holders
 Stitch markers
 Embroidery needle

TENSION

22 sts and 30 rows to 10cm over st st
 using 4mm needles.
 21 sts and 32 rows to 10cm over Knotted
 Rib pattern using 4mm needles.

YARN STOCKISTS

Erika Knight c/o Thomas B. Ramsden
 01943 8722640 www.tbramsden.co.uk

For general abbreviations, see p81

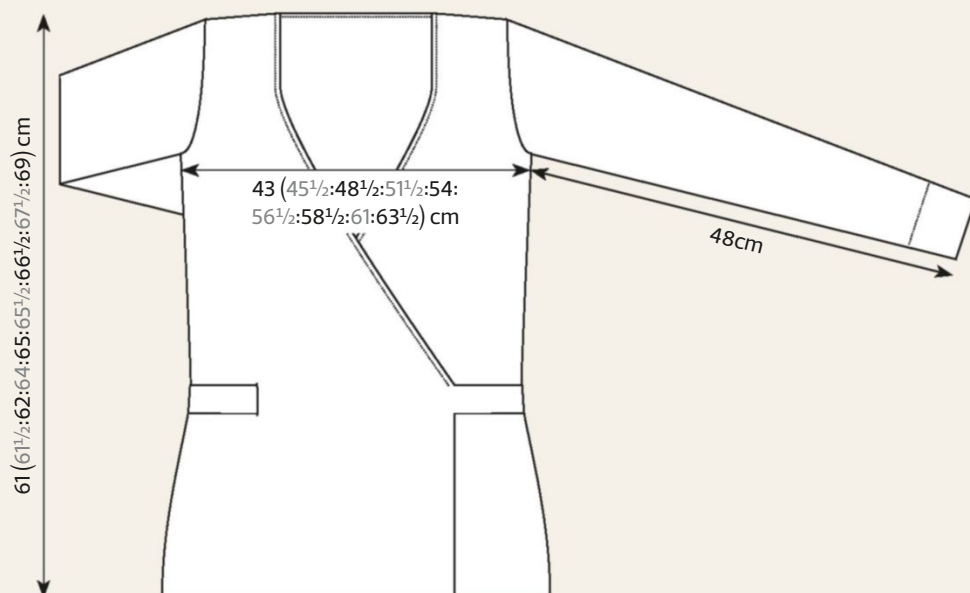
BLOCKING DIAGRAM

patt to last 6 sts, dec 1, pm, P1, KFB, P2.
 1 st inc'd at side, 1 st dec'd at neck.

Row 2 (WS): K2, P2tog, K1, slm, dec 1,
 patt to next mrk, slm, K to end.
 1 st dec'd at neck.

Row 3: P to mrk, remove mrk, P6 (6:6:6:7:
 7:7:8:9), M1P, pm, patt to 2 sts before mrk,
 dec 1, slm, P1, KFB, P2.

1 st inc'd at side, 1 st dec'd at neck.

Row 4: K2, P2tog, K1, slm, dec 1, patt to
 mrk, slm, K to end.
 1 st dec'd at neck.

Row 5: As Row 3.

Row 6: K2, P2tog, K1, slm, patt to mrk, slm,
 K to end.

Row 7: P1, M1P, P to mrk, remove mrk,
 P3 (3:4:4:4:4:5:5:5), pm, patt to 2 sts before
 mrk, dec 1, slm, P1, KFB, P2.

1 st inc'd at side, 1 st dec'd at neck.

Row 8: K2, P2tog, K1, slm, dec 1, patt to
 mrk, slm, K to end.
 1 st dec'd at neck.

Row 9: P to mrk, remove mrk, P3 (3:4:4:4:
 4:5:5:5), pm, patt to 2 sts before mrk, dec 1,
 slm, P1, KFB, P2.

1 st dec'd at neck.

Row 10: K2, P2tog, K1, slm, patt to mrk,
 slm, K to end.

61 (64:67:70:73:76:79:85:88) total sts:
 26 (26:28:29:31:31:34:36:38) sts in rev st st,
 31 (34:35:37:38:41:41:45:46) sts in Knotted
 Rib, 4 sts in neck.

Row 11 (RS): P1, M1P, P to mrk, remove
 mrk, P3 (3:4:4:4:4:5:5), pm, patt to 2 sts
 before mrk, dec 1, slm, P1, KFB, P2.

1 st inc'd at side, 1 st dec'd at neck.

Row 12 (WS): K2, P2tog, K1, slm, dec 1,
 patt to mrk, slm, K to end. 1 st dec'd at neck.

Row 13: P to mrk, remove mrk, P3 (3:4:4:4:
 4:4:5:5), pm, patt to 2 sts before mrk, dec 1,
 slm, P1, KFB, P2.
 1 st dec'd at neck.

Row 14: K2, P2tog, K1, slm, patt to mrk,
 slm, K to end.

59 (62:65:68:71:74:77:83:86) total sts:
 33 (33:37:38:40:40:43:47:49) sts in rev st st,
 22 (25:24:26:27:30:30:32:33) sts in Knotted
 Rib, 4 sts in neck.

Row 15 (RS): P1, M1P, P to mrk, remove
 mrk, P3 (3:3:4:4:4:4:5:5), pm, patt to 2 sts
 before mrk, dec 1, slm, P1, KFB, P2.

1 st inc'd at side, 1 st dec'd at neck.

Row 16: K2, P2tog, K1, slm, dec 1, patt to
 mrk, slm, K to end. 1 st dec'd at neck.

Row 17: P to mrk, slm, patt to 2 sts before
 mrk, dec 1, slm, P1, KFB, P2.

1 st dec'd at neck.

Row 18: K2, P2tog, K1, slm, patt to mrk,
 slm, K to end.

Rep last 4 rows once more.

55 (58:61:64:67:70:73:79:82) total sts:
 41 (41:45:48:50:50:53:59:61) sts in rev st st,
 10 (13:12:12:13:16:16:17) sts in Knotted
 Rib, 4 sts in neck.

Row 23 (RS): P to mrk, remove mrk,
 P2 (3:3:3:3:3:3:3:3), pm, patt to 2 sts before
 mrk, dec 1, slm, P1, KFB, P2.

1 st dec'd at neck.

Row 24 (WS): K2, P2tog, K1, slm, patt to
 mrk, slm, K to end.

Rep last 2 rows 1 (1:1:1:2:2:2) times more.

53 (56:59:62:65:67:70:76:79) total sts:
 45 (47:51:54:56:59:62:68:70) sts in rev st st,
 4 (5:4:4:5:4:4:4:5) sts in Knotted Rib,
 4 sts in neck.

Next row (RS): P to mrk, slm, patt to 2 sts
 before mrk, dec 1, slm, P1, KFB, P2.

1 st dec'd at neck.

Next row (WS): K2, P2tog, K1, slm, patt to
 mrk, slm, K to end.

Rep last 2 rows twice more.

50 (53:56:59:62:64:67:73:76) total sts:
 45 (47:51:54:56:59:62:68:70) sts in rev st st,
 1 (2:1:1:2:1:1:1:2) sts in Knotted Rib, 4 sts in
 neck.

Front should measure approx. same as Back
 to underarm.

SHAPE ARMHOLE

Next row (RS): Cast off 4 (4:5:6:6:7:8:9)
 sts, P to 2 sts before second mrk (removing
 first mrk) dec 1, slm, P1, KFB, P2.

45 (48:50:52:55:56:59:64:66) sts.

Next row (WS): K2, P2tog, K1, slm, K to
 end.

Note: Pattern is now worked in rev st st and
 neck pattern only, as set. Cont to work neck
 decs before mrk on RS and after mrk on
 WS. Armhole and neck shaping are worked
 AT THE SAME TIME.

Keeping in patt, dec 1 st at armhole edge of
 every row 1 (3:3:3:3:3:5:5:5) times, then
 every foll alt row 2 (2:3:4:6:7:6:8:9) times.
 AT THE SAME TIME, dec 1 st at neck edge ▶

Cicely

every RS row 14 (15:16:16:17:16:18:21:21) times more, then every foll 4th row twice. 26 (26:26:27:27:28:28:28:29) sts. Work even in patt until armhole meas 19 (20:20½:21:21½:22:23:23½:24) cm, ending after a RS row.

SHAPE SHOULDER

Next row (WS): Patt to last 7 (7:7:8:8:7:7:8) sts, turn.

Next row (RS): Patt to end.

Next row: Patt to last 14 (14:14:14:14:16:16:16:16) sts, turn.

Next row: Patt to end.

Break yarn and place sts on holder.

RIGHT FRONT

Using 3.75mm needles, cast on 74 (77:80:83:86:89:92:98:101) sts. Work 4 rows in Knotted Rib.

Change to 4mm needles.

Cont in Knotted Rib until work meas 10cm, ending after a WS row.

Keeping patt correct, dec 1 st at end of next row, then every foll 6th row 3 more times, then every foll 4th row 5 times.

65 (68:71:74:77:80:83:89:92) sts.

Work even in patt for 3 (3:3:4:4:2:4:4:8) rows.

BELT OPENING

Next row (RS): Patt 46 (49:52:55:58:61:64:67:70), join separate ball of yarn and patt 19 (19:19:19:19:19:22:22) sts to end.

Continuing to work each side separately with two balls of yarn, work 11 rows in patt. Cut second ball of yarn and cont in patt with 1 ball of yarn only for 2 rows more.

Note: Remember to work partial repeats of Knotted Rib patt in K2, P1 rib. Work neck decreases in rib patt.

Row 1 (RS): P2, KFB, P1, pm, dec 1, patt to last 4 (4:4:5:5:5:6:6) sts, pm, P to last st, PFB.

1 st inc'd at side, 1 st dec'd at neck.

Row 2 (WS): K to mrk, slm, patt to 2 sts before mrk, dec 1, slm, K1, P2tog, K2.

1 st dec'd at neck.

Row 3: P2, KFB, P1, slm, dec 1, patt to 6 (6:6:6:7:7:8:9) sts before mrk, pm, M1P, P to mrk, remove mrk, P to end.

1 st inc'd at side, 1 st dec'd at neck.

Row 4: K to mrk, slm, patt to 2 sts before mrk, dec 1, slm, K1, P2tog, K2.

1 st dec'd at neck.

Row 5: As Row 3.

Row 6: K to mrk, slm, patt to mrk, slm, K1, P2tog, K2.

Row 7: P2, KFB, P1, slm, dec 1, patt to 3 (3:4:4:4:4:5:5) sts before mrk, pm, P to mrk, remove mrk, P to last st, M1P, P1. 1 st inc'd at side, 1 st dec'd at neck.

Row 8: K to mrk, slm, patt to 2 sts before mrk, dec 1, slm, K1, P2tog, K2. 1 st dec'd at neck.

Row 9: P2, KFB, P1, slm, dec 1, patt to 3 (3:4:4:4:4:5:5) sts before mrk, pm, P to mrk, remove mrk, P to end. 1 st dec'd at neck.

Row 10: K to mrk, slm, patt to mrk, slm, K1, P2tog, K2. 61 (64:67:70:73:76:79:85:88) total sts: 26 (26:28:29:31:31:34:36:38) sts in rev st st, 31 (34:35:37:38:41:41:45:46) sts in Knotted Rib, 4 sts in neck.

Row 11 (RS): P2, KFB, P1, slm, dec 1, patt to 3 (3:4:4:4:4:4:5:5) sts before mrk, pm, P to mrk, remove mrk, P to last st, M1P, P1. 1 st inc'd at side, 1 st dec'd at neck.

Row 12 (WS): K to mrk, slm, patt to 2 sts before mrk, dec 1, slm, K1, P2tog, K2. 1 st dec'd at neck.

Row 13: P2, KFB, P1, slm, dec 1, patt to 3 (3:4:4:4:4:4:5:5) sts before mrk, pm, P to mrk, remove mrk, P to end. 1 st dec'd at neck.

Row 14: K to mrk, slm, patt to mrk, slm, K1, P2tog, K2. 59 (62:65:68:71:74:77:83:86) total sts: 33 (33:37:38:40:40:43:47:49) sts in rev st st, 22 (25:24:26:27:30:30:32:33) sts in Knotted Rib, 4 sts in neck.

Row 15 (RS): P2, KFB, P1, slm, dec 1, patt to 3 (3:3:4:4:4:4:5:5) sts before mrk, pm, P to mrk, remove mrk, P to last st, M1P, P1. 1 st inc'd at side, 1 st dec'd at neck.

Row 16 (WS): K to mrk, slm, patt to 2 sts before mrk, dec 1, slm, K1, P2tog, K2. 1 st dec'd at neck.

Row 17: P2, KFB, P1, slm, dec 1, patt to mrk, slm, P to end. 1 st dec'd at neck.

Row 18: K to mrk, slm, patt to mrk, slm, K1, P2tog, K2.

Rep last 4 rows once more.

55 (58:61:64:67:70:73:79:82) total sts: 41 (41:45:48:50:50:53:59:61) sts in rev st st, 10 (13:12:12:13:16:16:16:17) sts in Knotted Rib, 4 sts in neck.

Row 23 (RS): P2, KFB, P1, slm, dec 1, patt to 2 (3:3:3:3:3:3:3:3) sts before mrk, pm, P to mrk, remove mrk, P to end. 1 st dec'd at neck.

Row 24 (WS): K to mrk, slm, patt to mrk, slm, K1, P2tog, K2.

Rep last 2 rows 1 (1:1:1:2:2:2) times more.

53 (56:59:62:65:67:70:76:79) total sts: 45 (47:51:54:56:59:62:68:70) sts in rev st st, 4 (5:4:4:5:4:4:4:5) sts in Knotted Rib, 4 sts in neck.

Next row (RS): P2, KFB, P1, slm, dec 1, patt to mrk, slm, P to end. 1 st dec'd at neck.

Next row (WS): K to mrk, slm, patt to mrk, slm, K1, P2tog, K2.

Rep last 2 rows once more, then rep RS row once.

50 (53:56:59:62:64:67:73:76) total sts: 45 (47:51:54:56:59:62:68:70) sts in rev st st, 1 (2:1:1:2:1:1:1:2) sts in Knotted Rib, 4 sts in neck.

Front should meas approx. 1 row shorter than Back to underarm.

SHAPE ARMHOLE

Next row (WS): Cast off 4 (4:5:6:6:7:7:8:9) sts, then removing first mrk patt to last 6 sts, dec 1, slm, K1, P2tog, K2. 45 (48:50:52:55:56:59:64:66) sts.

Note: Pattern is now worked in rev st st and neck pattern only as set. Cont to work neck decs after mrk on RS and before mrk on WS. Armhole and neck shaping are worked at the same time.

Keeping in patt, dec 1 st at armhole edge of every row 1 (3:3:3:3:3:5:5) times, then every foll alt row 2 (2:3:4:6:7:6:8:9) times. AT THE SAME TIME, dec 1 st at neck edge every RS row 14 (15:16:16:17:16:18:21:21) times more, then every foll 4th row twice more.

26 (26:26:27:27:28:28:28:29) sts.

Work even in patt until armhole meas 19 (20:20½:21:21½:22:23:23½:24) cm, ending after a WS row.

SHAPE SHOULDER

Next row (RS): Patt to last 7 (7:7:8:8:7:7:8) sts, turn.

Work 1 row even in patt.

Next row: Patt to last 14 (14:14:14:14:16:16:16:16) sts, turn.

Work 1 row even in patt.

Break yarn and place sts on holder.

SLEEVES

(both alike)

Using 3.75mm needles, cast on 44 (44:44:44:47:47:50:50:53) sts. Work in Knotted Rib for 28 rows.

Change to 4mm needles.

Next row (RS): Purl, inc 6 sts evenly across. 50 (50:50:50:53:53:56:56:59) sts.

Cont in rev st st, inc 1 st at each end of every foll 8th (8th:8th:6th:6th:6th:6th:6th:6th) row 9 (11:11:12:14:15:15:11:7) times, then every 4th row 4 (4:5:6:4:4:4:9:14) times. 76 (80:82:86:89:91:94:96:101) sts. Work even in patt until Sleeve meas 48cm, ending after a WS row.

SHAPE SLEEVEHEAD

Keeping in patt, cast off 4 (4:5:6:6:7:7:8:9) sts at beg next 2 rows, then 3 (3:3:3:3:4:4:4:4) sts at beg of next 2 rows. 62 (66:66:68:71:69:72:72:75) sts.

Work 0 (0:0:0:0:0:0:2:2) rows even in patt. Dec 1 st at each end of next row, then every foll alt row 5 (6:8:9:9:10:12:12:13) times, then every foll row 10 (10:10:10:11:11:10:11:11) times. 30 (32:28:28:29:25:26:24:25) sts. Cast off 5 (5:4:4:4:3:3:3:3) sts at beg of next 2 rows, then cast off rem 20 (22:20:20:21:19:20:18:19) sts.

TIES

Place a removable marker 31 rows below removable marker at beginning of neck shaping at edge of each front.

LEFT TIE

Using 4mm needles and with RS of Left Front facing, pick up and knit 16 sts between markers.

Row 1 (WS): Knit.

Row 2 (RS): P2, KFB, P to last 6 sts, (KFB, P2) twice. 19 sts.

Row 3: (K2, P2tog) twice, K to last 6 sts, K2tog, P2tog, K2. 4 sts decreased.

Row 4: P2, KFB, P2tog, P to last 6 sts, (KFB, P2) twice. 2 sts inc'd.

Rep last 2 rows once more, then rep Row 3 once. 11 sts.

Next row (WS): (P2, KFB) 3 times, P2.

Next row: (K2, P2tog) 3 times, K2.

Rep last 2 rows until tie meas 78 (80:84:84:86:88:90:92:94) cm from pick-up. Cast off.

RIGHT TIE

Using 4mm needles and with RS of Right Front facing, pick up and knit 16 sts between markers.

Row 1 (WS): Knit.

Row 2 (RS): (P2, KFB) twice, P7, KFB, P2. 19 sts.

Row 3: K2, P2tog, K2tog, K to last 6 sts, (P2tog, K2) twice. 4 sts dec'd.



Simple embroidery appears on the fronts, cuffs and back neck

Row 4: (P2, KFB) twice, P to last 5 sts, P2tog, KFB, P2. 2 sts inc'd. Rep last 2 rows once more, then rep Row 3 once. 11 sts.

Next row: (P2, KFB) 3 times, P2.

Next row: (K2, P2tog) 3 times, K2. Rep last 2 rows until tie meas 78 (80:84:84:86:88:90:92:94) cm from pick-up. Cast off.

MAKING UP

Block pieces to measurements, following any yarn care instructions on the ball band.

Join outer 22 (22:22:23:23:24:24:24:25) sts of shoulders, leaving 4 sts of neck on each side of front on holder.

Place 4 sts held for Right Front and cont in patt on these sts until piece reaches centre of back neck when stretched. Cast off in patt. Repeat for Left Front.

Sew both bands to back neck, easing to fit. Sew cast-off edges of bands together.

Embroider Fronts and Sleeve Cuffs using simple stitch and bullion stitch, using photographs for guidance. (See also our Q&A article on page 18 for more information on worked bullion stitch.)

132 PAGES OF ON-TREND CROCHET AND NEW TECHNIQUES

Mollie
MAKES

107 GIFTS, GARMENTS, PATTERNS
& TECHNIQUES TO HOOK UP

CROCHET

HOME • FASHION • QUICK MAKES • AMIGURUMI • GIFTS

TOP DESIGNERS
FLAX & TWINE
HANJAN CROCHET
ILARIA CALIRI
KAT GOLDIN
REDAGAPE

36 FRESH PROJECTS

INSIDE: STEP-BY-STEP PATTERNS • BEGINNER'S HOW TO

JUST
£8.99!*

The team behind *Mollie Makes* bring you a collection of contemporary crochet patterns for **enthusiasts of all levels**. Our easy-to-follow projects created by **top crochet designers** will inspire you to hook clothes, gifts, home accessories and more. Plus there's a handy **beginner's guide** so you can start right away!

ORDER YOUR COPY TODAY!

Call 03330 162 138 AND QUOTE 'MOLLIE MAKES CROCHET 2018 PRINT 1'

Online WWW.BUYSUBSCRIPTIONS.COM/CRAFTSPECIAL

Lines open weekdays 8am to 6pm and Saturday 9am to 1pm. Overseas please call +44 (0) 3330 162 138.

* EUR price £11.99, ROW price £12.49. All prices include P&P. Please allow up to 28 days for delivery.

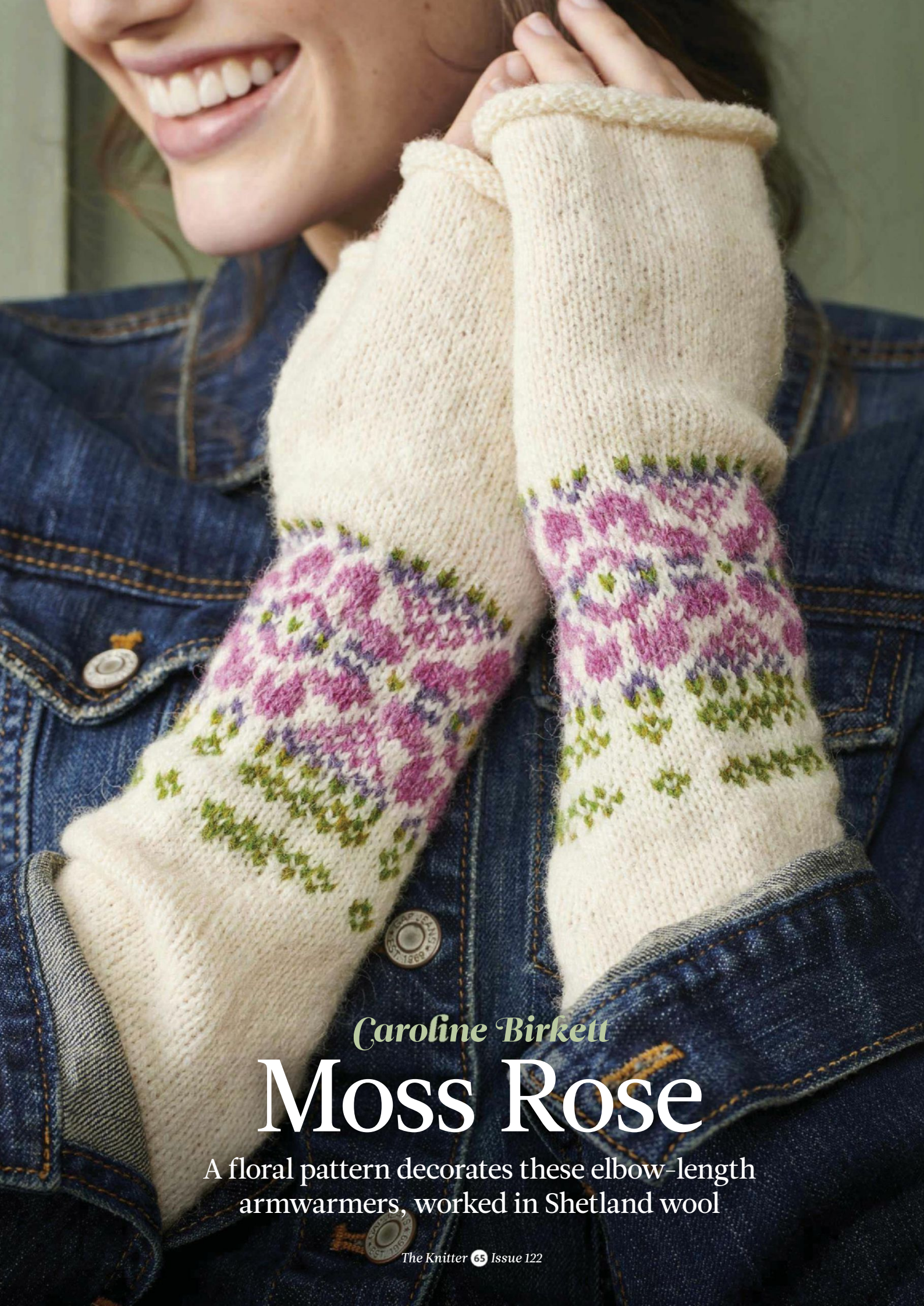

Caroline Birkett

Moss Rose

A floral pattern decorates these elbow-length armwarmers, worked in Shetland wool



Caroline Birkett
Moss Rose

SPRING MAY be officially here, but there's every chance we'll have more than a few chilly days ahead! Keep your arms feeling toasty with these elbow-length mitts, designed by Caroline Birkett. They're decorated with a pretty stranded colourwork rose pattern, and finished with simple rolled edges. The armwarmers use Jamieson & Smith's classic Jumper Weight yarn. This is a 4ply Shetland wool that comes in a huge choice of colours, so you can pick the perfect shades to complement your coat!

ARMWARMERS

(make 2)

Using 3mm needles and yarn A, cast on 64 sts using the long-tail method. Pm and join to work in the round, taking care not to twist sts.

Knit 40 rounds.

Dec round: K1, K2tog, K to last 2 sts, SSK. 2 sts dec'd.

Work 9 rounds in st st.

Rep last 10 rounds, 3 more times, then work Dec round once more. 54 sts.

Work rounds 1 to 3 from Chart A.

Knit 3 rounds in yarn A.

Work rounds 1 to 3 from Chart A.

Knit 1 round in yarn A.

Work rounds 1 to 23 from Chart B.

Cut yarns B, C and D and cont in yarn A.

Knit 1 round.

SIZE

Actual palm circumference: 19cm (7½in)

Length: 41cm (16in)

YARN

Jamieson & Smith 2ply Jumper Weight (4ply weight; 100% Shetland wool; 125m/136yds per 25g ball)

A Shade 1A; 2 x 25g balls

Plus 1 x 25g ball of each:

B Shade FC11; **C** Shade FC9; **D** Shade FC22

NEEDLES & ACCESSORIES

Set of 3mm (UK 11/US 2-3) double-pointed needles (DPNs), or circular needles,

60cm long, for Magic Loop method

Stitch markers

Stitch holder

Right hand

Next round: K13, pm, K2, pm, K to end.

Left hand

Next round: K40, pm, K2, pm, K to end.

THUMB GUSSET

Inc round: K to mrk, slm, M1R, K to next mrk, M1L, slm, K to end. 2 sts inc'd.

Next round: Knit.

Rep last 2 rounds until there are 18 sts between the markers.

Knit 4 rounds.

HAND

Next round: K to mrk, place 18 sts between mrks on a holder, cast on 2 sts, K to end of round. 54 sts.

Knit 24 rounds.

Cast off.

THUMB

Slip 18 sts for gusset onto a 3mm DPN or circular needle. Pm to mark beg of round.

With yarn A, pick up and knit 1 st in the space before the cast-on sts, pick up and knit 2 sts over the cast-on sts and 1 st in the space after them, K18. 22 sts.

Next round: (K2tog) twice, K to end. 20 sts.

Knit 12 rounds.

Cast off.

TO MAKE UP

Weave in ends and gently block to measurements, following any yarn care instructions on the ball band. ☺

TENSION

28 sts and 42 rows to 10cm over st st on 3mm needles.

34 sts and 34 rows to 10cm over Fair Isle patt on 3mm needles.

YARN STOCKISTS

Jamieson & Smith

01595 693579

www.shetlandwoolbrokers.co.uk

For general abbreviations, see p81

CHARTS

Chart A

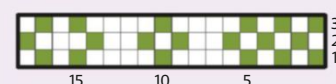
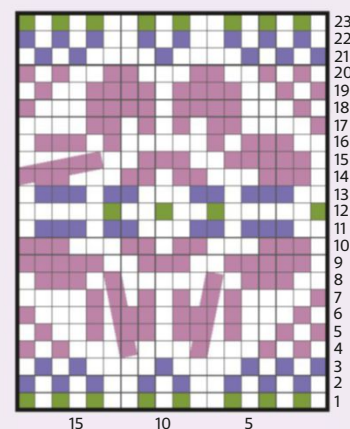

Chart B



KEY

□ Yarn A □ Yarn C
■ Yarn B ■ Yarn D



The armwarmers are gently shaped so that they fit well on the arms

Moss Rose



Rose and leaf pattern
evokes traditional
Shetland styles

KNITTING FROM THE CENTRE OUT

Faye Perriam-Reed explores three different circular cast-on techniques to try on your next centre-out shawl or hat project

CIRCULAR SHAWLS, toys and hats are just a few of the projects that might require a circular cast-on technique. In crochet, working from the centre out is considered the norm - the humble granny square, for example, might be the perfect beginner's project. However, in knitting, we have a tendency to work from the outside in.

There are a few different methods to cast on from the inside of a circle, and they all produce slightly different results and are of varying levels of fiddliness! The three I've explored here are the most common techniques. They will give a few different options, depending on your preferences - the first uses a crochet hook, the second uses a knitting needle, and the third begins from an i-cord. Although the first two might seem a bit tricky at first, they do become much easier with practice!

For all three examples, I cast on six stitches and increased six stitches evenly on every alternative round, closing the loop shut after about ten rounds of knitting.



About our expert
Faye Perriam-Reed is a designer and the technical of *The Knitter* and *Simply*

Knitting. She enjoys exploring how different knitting techniques can be used to achieve neater results.

DISAPPEARING LOOP CAST-ON

This is my favourite cast-on of the three - I'm a fan of the long-tail cast-on, and this feels like it flows nicely, alternating yarnovers with catching the working yarn through the loop. The result is a neat join with little bulk, and a very satisfying loop-closure when you pull the tail!

- ❶ Make a loop over your left forefinger with the yarn, letting the tail fall to the left at the front of the loop, and taking the working yarn over your middle finger. Hold the loop shut with your thumb and forefinger.
- ❷ Turn your left hand to face away from you and slip the knitting needle behind the working yarn from bottom to top to create a yarnover.
- ❸ Keeping the needle where it is, twist your left hand back around to face you, creating a loop on the needle. This is your first stitch.
- ❹ Take the needle under the two loops on your forefinger from right to left....
- ❺ ...and pick up the working yarn by taking the needle over it, then pulling the

working yarn down and through the loop on to the needle (❻).

❷ This time, take the needle under the working yarn from front to back to create a yarnover.

❸ Repeat steps 4-7 until the required number of stitches are on the needle.

To begin knitting in the round, transfer the stitches on to a set of DPNs or circular needles, and arrange to work in the round. Tighten the loop after a few rounds.

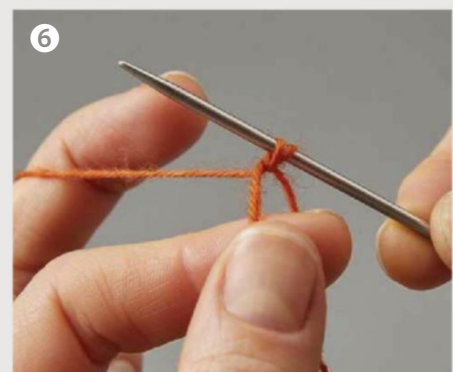

EMILY OCKER'S CAST-ON

Emily Ocker's Circular Cast-on is probably the most common of all the circular cast-on techniques, and one that you might have tried already if you have made any toys or circular shawls. If you're a crocheter, this will look familiar, as it can be seen as the knitting equivalent of a crochet Magic Loop (not to be confused with magic loop knitting).

- 1 Make a loop with your yarn, with the tail end of the yarn going over the top of the loop and over to the right.
- 2 Hold the loop closed with your left hand and keeping hold of the tail in your right hand, insert a crochet hook slightly smaller than the needles you will be knitting with into the loop and under the working yarn, catching hold of the yarn and bringing it through the loop.
- 3 Take the hook over the loop and under the working yarn, catching the yarn and bringing it through the loop on the hook. You might find you need to gently pull down on the loop with your forefinger and thumb to help pull the new loop through. Draw to close, to create one stitch.
- 4 Repeat steps 2 and 3 until the required number of stitches are on the hook. To knit in the round, transfer the stitches on to a set of DPNs or circular needles, and arrange to work in the round. Tighten the loop after a few rounds.

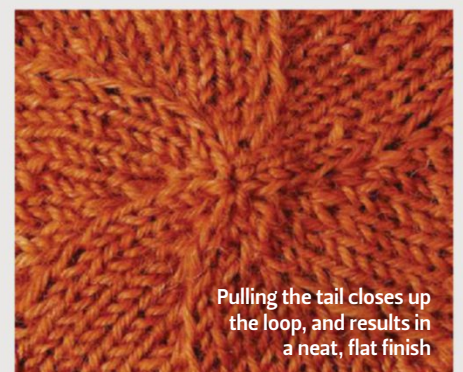
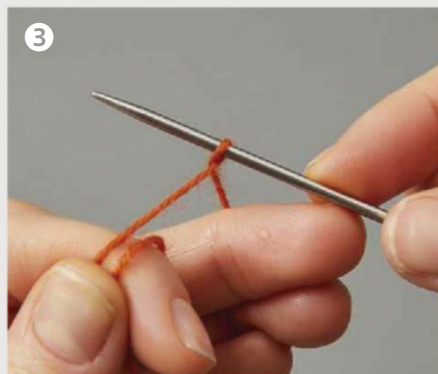
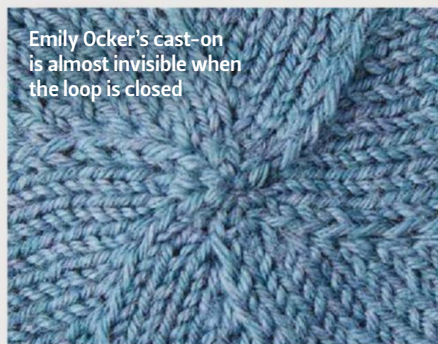
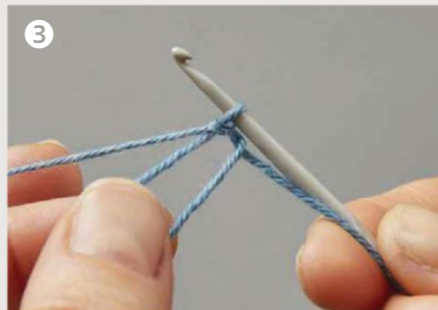
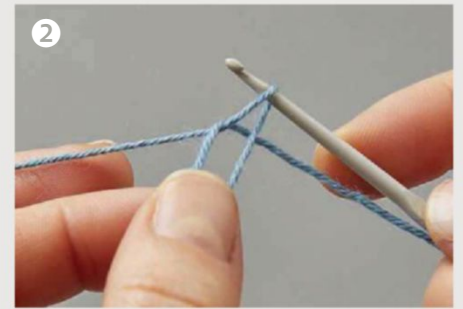
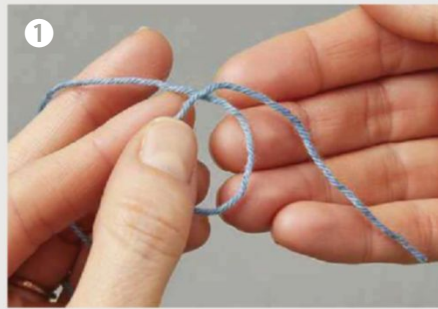

Masterclass

I-CORD STARTING CAST-ON

This method is a good one if you are struggling with the other two techniques, or are having trouble keeping the stitches on your needles.

❶ Using waste yarn and DPNs the same size as your project needles, cast on the required number of sts using the long-tail cast-on method.

❷ *Knit across all sts, then slide sts to the right-hand side of the working needle without turning work.

❸ Repeat step 2 until the i-cord measures 1-2cm.

You can choose now whether to distribute the stitches evenly onto a set of DPNs, or work a few increase rows first to make this a bit easier (see tip box below).

❹ Change to the main project yarn and work across all stitches. This will become your first pattern round.

❺ (Optional) Split the stitches evenly over two DPNs. Work the next couple of rounds over two needles only, working across the front needle, turning and then working across the back (now front) needle.

❻ Continue this way until enough stitches have been increased to make slipping the stitches onto DPNs a bit 'safer' as there are now more stitches to grip the needles. You can remove the waste yarn when you're just a few rounds into the project - this way, if anything goes wrong, there is less at stake!

❼ Thread a tapestry needle with the tail end of the main yarn and unpick the waste yarn stitch by stitch, slipping the live loops onto the tapestry needle as you go. When you reach the end, go into the first stitch once more and then pull the yarn gently to close up the hole.



Once the i-cord is removed, the work will lie flat and tidy

SMALL CIRCUMFERENCES

Working with a small number of stitches straight into the round on DPNs can be frustrating if you're using slippery needles that keep sliding out. Until you've increased to 24 stitches or so, you might find it easier to work in the round on circular needles, or over two DPNs, splitting the stitches evenly over them and holding both in your left hand, but only knitting across the front needle before turning and knitting across the second needle. When there are enough stitches, you can then transfer to three or four DPNs, depending on your preference or the multiple of stitches you are working with.



'Setting Sun' from Issue 27 is worked from the centre out



Bergère de France

Camille & Loïc

Get creative with textures to make these relaxed merino sweaters for men and women



Bergère de France
Camille

A **FRESH** colour and a soft, lightweight yarn ensure this Aran-style sweater for women will make a lovely layering piece for your spring wardrobe. The design has a high ribbed turtleneck and an attractive central cable panel; cable details are also worked up the sleeves. The garment uses a pure merino wool from the Falkland Islands, which is wonderfully fine and soft, and is also machine-washable. It is available in 19 shades, ranging from sophisticated neutrals to brights and pastels.

BACK

Using 3.5mm needles, cast on 100 (110:118:130:140) sts.

Row 1: P3 (0:0:2:3) (K2, P2) to last 5 (2:2:4:5) sts, K2, P3 (0:0:2:3).

Last row sets rib.

Cont to work in rib until work meas 5cm.

Change to 4mm needles.

Next row (RS): K18 (23:27:33:38), P2, Sl1, P2, M1, K2, M1, P2, Sl1, P2, K2, M1, K1, P6, M1, K2, M1, (P8, M1, K2, M1) twice, P6, K1, M1, K2, P2, Sl1, P2, M1, K2, M1, P2, Sl1, P2, K18 (23:27:33:38).

112 (122:130:142:152) sts.

Next row (WS): P18 (23:27:33:38), (K2, P1, K2, P4) twice, K6, P4, (K8, P4) twice, K6, (P4, K2, P1, K2) twice, P18 (23:27:33:38).

BEGIN CHARTS

Next row: K18 (23:27:33:38), work Chart A twice, work Chart B, work Chart C twice,

SIZE

	S	M	L	1XL	2XL	
TO FIT BUST	84	94	102	112	122	cm
	33	37	40	44	48	in
ACTUAL BUST	88	96	104	114	124	cm
	34½	37¾	41	45	49	in
ACTUAL LENGTH	58	60	62	64	66	cm
	23	23½	24½	25	26	in
SLEEVE SEAM	46	47	47	47	48	cm
	18	18½	18½	18½	19	in

YARN

Bergère de France Mérinos 4 (DK weight; 100% merino wool; 135m/147½yzds per 50 ball)

AMÉTHYSTE (20084)	10	11	12	13	14	x50g BALLS
-------------------	----	----	----	----	----	------------

K to end.

Next row: P18 (23:27:33:38), work Chart C twice, work Chart B, work Chart A twice, P to end.

Last 2 rows set Chart placement.

Cont to work as set, repeating rows 1-6 of Charts A and C and rows 1-20 of Chart B until work meas 39 (40:40:41:42) cm.

SHAPE ARMHOLES

Cast off 4 sts at beg of next 0 (0:0:2:2) rows, 3 sts at beg of next 2 (2:4:2:4) rows, 2 sts at beg of next 4 (6:4:6:6) rows, then 1 st at beg of next 8 (6:6:8:8) rows.

90 (98:104:108:112) sts.**

Continue on the rem 90 (98:104:108:112) sts until work meas 56 (58:60:62:64) cm.

SHAPE SHOULDERS AND NECK

Next row (RS): Cast off 5 (5:6:6:6) sts, patt 20 (23:24:24:25), cast off 40 (42:44:48:50) sts for the neck, patt to end.

Next row (WS): Cast off 5 (5:6:6:6) sts, patt to neck edge and leave rem sts on a holder. Each side of work will now be completed separately.

*Cast off 3 sts at neck edge of next row and 2 sts on the foll RS row, AT THE SAME TIME casting off 5 (6:6:6:6) sts at the beg of foll 3 (3:2:2:1) WS rows and 0 (0:7:7:7) sts at the beg of the foll 0 (0:1:1:2) WS rows. *

With WS of work facing rejoin yarn to rem sts.

NEEDLES & ACCESSORIES

1 pair 3.5mm (UK 10-9/US 4) knitting needles
1 pair 4mm (UK 8/US 6) knitting needles
Cable needle (cn)
Stitch holders

TENSION

22 sts and 28 rows to 10cm over st st on 4mm needles.
76-st panel of Charts A, B and C measures 28cm wide.

Cast off 5 (6:6:6:6) sts at the beg of next row and 2 (2:1:1:0) foll RS rows and 0 (0:7:7:7) sts at the beg of the foll 0 (0:1:1:2) RS rows, AT THE SAME TIME casting off 3 sts at neck edge of next row and 2 sts on the foll WS row.

FRONT

Work as for Back to **.

Continue on the rem 90 (98:104:108:112) sts until work meas 52 (54:56:58:60) cm.

NECK

Next row (RS): Patt 28 (31:33:33:34), cast off 34 (36:38:42:44) sts for the neck, patt to end.

Next row (WS): Patt to neck edge and leave rem sts on a spare needle.

Each side of work will now be completed separately.

Cast off 3 sts at neck edge of next row, 2 sts at the beg of the foll RS row and 1 st at the beg of the foll 3 RS rows.
20 (23:25:25:26) sts.

SHOULDERS

Cont without shaping until work meas 56 (58:60:62:64) cm, ending with a RS row.

Cast off 5 (5:6:6:6) sts at the shoulder edge of next 4 (1:3:3:2) alt rows, then 0 (6:7:7:7) sts at the shoulder edge of next 0 (3:1:1:2) alt rows.

With WS of work facing rejoin yarn to rem

CHART

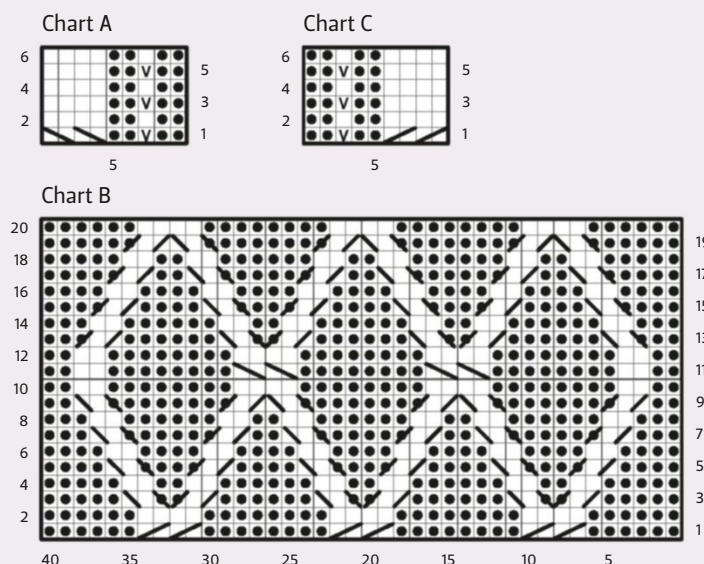

KEY



YARN STOCKISTS

Bergère de France
www.bergerefrance.co.uk

SPECIAL ABBREVIATIONS

C4F: Slip 2 sts to cn and hold at front, K2, K2 from cn.
C4B: Slip 2 sts to cn and hold at back, K2, K2 from cn.
T3B: Slip 1 st to cn and hold at back, K2, P1 from cn.
T3F: Slip 2 sts to cn and hold at front, P1, K2 from cn.

For general abbreviations, see p81

sts and work as for right shoulder, reversing shapings.

SLEEVES

Using 3.5mm needles, cast on 52 (54:56:58:60) sts.

Next row: K1 (0:0:0:1), P0 (2:3:0:0), (K2, P2) to last 3 (4:5:2:3) sts, K2, P0 (2:3:0:0), K1 (0:0:0:1).

Change to 4mm needles.

Next row (RS): K12 (13:14:15:16), P2, Sl1, P2, K2, M1, K1, P2, Sl1, P2, M1, K2, M1, P2, Sl1, P2, K1, M1, K2, P2, Sl1, P2, K to end.
56 (58:60:62:64) sts.

Next row (WS): P12 (13:14:15:16), (K2, P1, K2, P4) 3 times, P2, K1, P2, P12 (13:14:15:16).

BEGIN CHARTS

Next row: K12 (13:14:15:16), work Chart A twice, P2, Sl1, P2, work Chart C, K12 (13:14:15:16).

Next row: P12 (13:14:15:16), work Chart C, K2, P1, K2, work Chart A twice, P12 (13:14:15:16).

Last 2 rows set Chart pattern.

Cont in pattern as set until work meas 9cm.

Next row (RS inc): K2, M1, patt to last 2 sts, M1, K2.

Rep Inc row every foll 12th (12th:10th:8th:8th) row 5 (2:4:7:2) more times, then on every 10th (10th:8th:6th:6th) row 3 (7:7:14) times.
74 (78:84:92:98) sts.

BLOCKING DIAGRAM

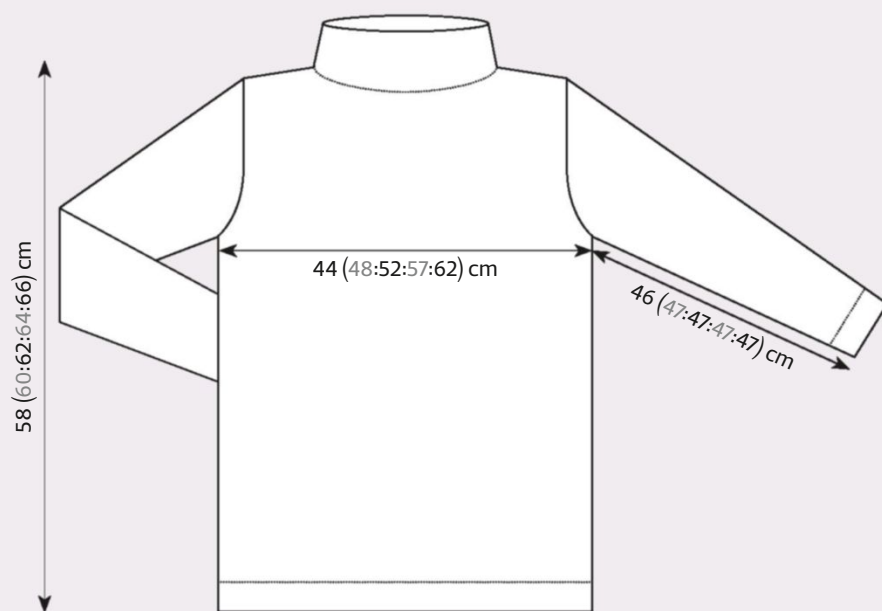

Cont without shapings until work meas 46 (47:47:47:48) cm.

SHAPE SLEEVE CAP

Cast off 4 sts at beg of next 0 (0:0:0:2) rows, 3 sts at beg of next 2 (2:4:4:4) rows, 2 sts at beg of next 4 (6:4:6:4) rows, 1 st at beg of next 22 (20:24:22:22) rows, 2 sts at beg of next 6 (4:4:6:4) rows, 3 sts at beg of foll 2 (4:4:2:4) rows and 4 sts at beg of foll 0 (0:0:2:2) rows.
Cast off rem 20 sts.

NECKBAND

Using 3.5mm needles, cast on

118 (122:126:130:134) sts.

Row 1: K2, (P2, K2) to end.

Row 2: P2, (K2, P2) to end.

Rep Rows 1 and 2 until work meas 10cm.
Cast off.

MAKING UP

Join the shoulders.
Graft the neckband around the neck edge.
Join the short seams. Sew the tops of the sleeves into the armholes.
Sew the sleeve and side seams.
Weave in all ends and block to measurements, following any yarn care instructions on the ball band. ☺ ▶



Bergère de France
Loïc

THIS COMFORTABLE sweater for men has a sporty look with its drawstring neck and loose fit. The textured stitch pattern gives an interesting look to the fabric. The collar is knitted separately, attached to the neck, then folded over and stitched before being threaded with a twisted cord. The yarn used is a pure merino DK-weight wool from the Falkland Islands, which is soft and smooth, and can be machine washed.

BACK

Using 3.5mm needles, cast on 103 (111:121:129:139) sts.
Work in 1x1 rib for 4cm.

Change to 4mm needles.
Begin pattern as follows:

Row 1: Beg on st 5 (1:5:1:5) and ending on st 8 (3:8:3:8), work row 1 of Chart to end.

Row 2: Beg on st 8 (3:8:3:8) and ending on st 5 (1:5:1:5), work row 2 of Chart to end.

Cont to work as set by last 2 rows, repeating 10 rows of Chart until work meas 46 (47:48:48:49) cm.

SHAPE ARMHOLES

Cast off 4 sts at beg of next 2 rows.
95 (103:113:121:131) sts.**

Cont without shaping until work meas 64 (66:68:70:72) cm.

SHAPE SHOULDERS AND NECK

Next row (RS): Cast off 7 (8:8:9:10) sts, patt until there are 27 (29:32:34:37) sts on the RH needle, cast off 27 (29:33:35:37) sts

SIZE

	S	M	L	1XL	2XL	
TO FIT CHEST	84	94	102	112	122	cm
	33	37½	40	44	48	in
ACTUAL CHEST	93½	101	110	117	126	cm
	37	39¾	43¼	46	49¾	in
ACTUAL LENGTH	66	68	70	72	74	cm
	26	26¾	27½	28¾	29	in
SLEEVE SEAM	59	59	59	59	59	cm
	23¼	23¼	23¼	23¼	23¼	in

YARN

Bergère de France Mérinos 4 (DK weight; 100% merino wool; 135m/147½yds per 50 ball)

HÉTRE (20078)	10	11	12	13	14	x50g BALLS

NEEDLES & ACCESSORIES

1 pair 3.5mm (UK 10-9/US 4) knitting needles
1 pair 4mm (UK 8/US 6) knitting needles
Stitch holders

TENSION

22 sts and 28 rows to 10cm over pattern on 4mm needles

YARN STOCKISTS

Bergère de France
www.bergeredefrance.co.uk

For general abbreviations, see p81

for the neck, patt to end.

Next row (WS): Cast off 7 (8:8:9:10), patt to neck edge and leave rem sts on a holder.

Each side of work will now be completed separately.

Cast off 3 sts at neck edge of next row and 2 sts at beg of foll RS row, AT THE SAME TIME casting off 7 (8:9:9:10) sts at shoulder edge of next 2 (3:3:1:1) WS rows and 8 (0:0:10:11) sts at beg of foll 1 (0:0:2:2) WS rows.

With WS of work facing rejoin yarn to rem sts.

Cast off 7 (8:9:9:10) sts at shoulder edge of next row and foll 1 (2:2:0:0) WS rows and 8 (0:0:10:11) sts at beg of foll 1 (0:0:2:2) WS rows, AT THE SAME TIME casting off 3 sts at neck edge of next RS row and 2 sts at beg of foll RS row.

FRONT

Work as for Back to **.

Continue without shaping until work meas 58 (60:62:64:66) cm.

SHAPE NECK

Next row (RS): Patt 39 (42:45:48:52), cast off 17 (19:23:25:27) sts for the neck, patt to end.

Next row (WS): Patt to neck edge and leave rem sts on a spare needle.

Each side of work will now be completed separately.

Cast off 3 sts at neck edge of next row,

2 sts at neck edge of foll 2 alt rows and 1 st at the neck edge of the foll 3 alt rows.
Cont on the rem 29 (32:35:38:42) sts until work meas 64 (66:68:70:72) cm.

SHAPE SHOULDERS

Cast off (7:8:8:9:10) sts at shoulder edge of next 3 (4:1:2:2) alt rows, then 8 (0:9:10:11) sts at shoulder edge of foll 1 (0:3:2:2) alt rows.

With WS of work facing rejoin yarn to rem sts and work as for right shoulder, reversing shapings.

SLEEVES

Using 3.5mm needles, cast on 53 (55:57:59:61) sts.
Work in 1x1 rib for 4cm.

Change to 4mm needles.

Row 1: Beg on st 3 (2:1:9:8) and ending on st 1 (2:3:4:5), work row 1 of Chart to end of row.

Row 2: Beg on st 1 (2:3:4:5) and ending on st 3 (2:1:9:8), work row 2 of Chart to end.
Cont to work as set by last 2 rows, repeating 10 rows of Chart until work meas 7cm.

Next row (RS inc): K1, M1, patt to last st, M1, K1.

Rep Inc row on every foll 10th (10th:8th:8th:8th) row 10 (6:14:6:3) more times, then on every 8th (8th:6th:6th:6th) row 3 (8:2:13:17) times.
81 (85:91:99:103) sts.

Cont without shaping until work meas 59cm.

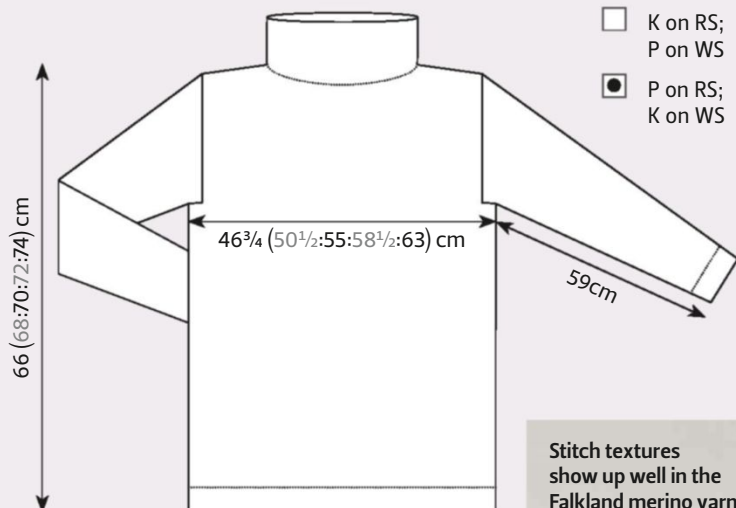
BLOCKING DIAGRAM**KEY**

- K on RS;
P on WS
- P on RS;
K on WS

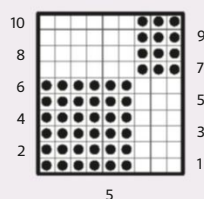
CHART

These designs also appear in the Bergère de France magazine, *Mérimos* 4 & 7, which has patterns for men, women and children. To order

a copy or to find stockist details, visit www.bergeredefrance.co.uk.

Stitch textures show up well in the Falkland merino yarn

Cast off.

COLLAR

Using 4mm needles, cast on 99 (103:111:115:119) sts.
Work in st st for 15cm.
Cast off.

FINISHING

Join the shoulders.
Graft collar around neck edge.
Join the short seams.
Using back stitch, sew tops of the sleeves into the vertical part of the armholes.
Sew the sleeve and side seams.

HEM

Fold 2cm at the top of the collar to the WS and hem in place.

CORD

Cut 4 strands of yarn approx. 360cm long. Knot the strands together at both ends and insert a pencil between the strands at one end. Pin down the knot at the other end. Twist the pencil around and around until the cord is tightly twisted and wants to fold in on itself. Fold the yarn at the halfway point and remove the pencil. Knot the folded end and trim ends.

Slip the cord through the hem on the collar, between the stitches on the RS of work either side of the 22 central stitches of the Front.

Weave in ends and block garment to measurements, following any yarn care instructions on the ball band. ☺





Your essential buying guide to the best suppliers of yarn & knitting accessories

To advertise in *The Knitter Boutique* please contact **Steph Broadbent** on 0117 300 8538 or **Chris Gibson** on 0117 300 8109

SOUTH WEST



Spin A Yarn

www.spinayarndevon.co.uk
customerservices@spinayarndevon.co.uk
01626 836203

Exciting and unusual yarns from around the world. Rare and Touch yarns from NZ, Rowan, Debbie Bliss, Noro, Arctic Qiviut, Malabrigo and Juniper Moon.

26 Fore Street, Bovey Tracey, Devon, TQ13 9AD

ONLINE



John Arbon Textiles

www.jarbon.com
info@jarbon.com
01598 752490

British manufacturers of luxury yarns and tops... from VIOLA to ALPACA SUPREME to KNIT BY NUMBERS, etc. Based in Devon, we are one of the few worsted processing and spinning mills still operating in Britain.

ONLINE



Knitting Needle Lane

knittingneedlelane.co.uk
01223 561865

A modern twist on a traditional hobby for all your knitting/crochet needs. You can also find us at Cambridge Market every Sunday. We sell Sirdar, James C Brett, Wendy, Manos Del Uruguay and Erika Knight. We have the beauty of handpicking our skeins before they go online to sell or reach our market stall.

ISLE OF WIGHT



Knit Knacks

www.facebook.com/knitknacksiow
01983 716890

'An old fashioned wool shop with a modern twist'

Stockists of James C Brett, Stylecraft and Woolcraft wools, Knitting needles, crochet hooks etc. DMC embroidery silks Haberdashery and gifts from Vanessa Bee Designs.

11 Sandown Road Lake, Isle of Wight, PO36 9JL

NORTH EAST/ONLINE



Fine Fettle Fibres

www.finefettlefibres.co.uk
judith@finefettlefibres.co.uk
01670 600001

Specialising in British and fair trade yarns in natural fibres, Fine Fettle Fibres also offers workshops, knitting groups and special events for knitters.

Studio 6, Gallery 45, 45 Main Street, Felton, Northumberland NE65 9PP

SOUTH CENTRAL



Oxford Yarn Store

www.oxfordyarnstore.co.uk
info@oxfordyarnstore.co.uk
01865 604112

Exquisite yarns and notions for all tastes. SweetGeorgia, Isager, The Fibre Co, Malabrigo, Manos Del Uruguay, Rooster Yarns, Rowan, Debbie Bliss, Louisa Harding, John Arbon, Araucania.

3 North Parade Ave, Oxford, OX2 6LX

ONLINE



Cambrian Mountains Wool

www.cambrianwool.co.uk
info@cambrianwool.co.uk

A community interest company developing fine yarns from wool grown by the sheep of Mid Wales. Available online and from selected retailers.

ONLINE



Frangipani

www.guernseywool.co.uk
jan@guernseywool.co.uk
01326 240367

Beautiful **5-ply Guernsey Wool** Announcing a new shade "HELFDOR BLUE" Still **28 glorious colours** to knit your own gansey.

'Lamana', White Cross, Cury, Helston, Cornwall TR12 7BG

ONLINE



Willow Knits

www.willowknits.etsy.com
mail@willowknits.com
02083 632884

We specialise in hand-dyed silks for luxury knitting and crochet. Worsted, 4-Ply and Lace weights are available in a wide range of colours. Custom orders are welcome too.

SOUTH



Liss Wools

Jacquiekennedy6@gmail.com
www.lisswools.co.uk
01730 893941

Friendly, well stocked shop with a wide variety of yarns, knitting accessories, haberdashery, patterns, buttons and much more.

Monday- Saturday 10am-5pm
Easy, free parking in the village.
38-40 Station Road, Liss, GU33 7DP

SOUTH EAST



The Yarn Dispensary

www.theyarndispensary.co.uk
Design led natural fibres specialist in a beautiful medieval building.
Workshops, events, Knit Night.
Hedgehog Fibres, Erika Knight, Fyberspates, Sylvan Tiger, The Knitting Goddess, Socks Yeah, Baa Ram Ewe, Navia, SweetGeorgia, The Fibre Co., Sublime, Debbie Bliss, KnitPro, PomPom Quarterly.
6 Market Place, Faversham, Kent, ME13 7AG

SOUTH EAST



Ida's House

idashouse.co.uk
01883 345220

Ida's House is friendly shop just 10 mins from Junction 6 on the M25. We are proud supporters of British wool and stock West Yorkshire Spinners, Baa Ram Ewe, Rico and Stylecraft. Twice weekly social evenings and Knitting and Crochet classes listed on our website.
27 High Street, Caterham CR3 5UE

NORTH/NORTH WEST



Sew-In of Marple, Buxton & Cheadle

www.myknittingyarnandwool.co.uk
enquiries@myknittingyarnandwool.co.uk
0161 427 2529
Three high street gems stocking all that's best in handknitting!
Sublime, WYS, Rowan, Sirdar, Rico and more. Extensive selection of needlecraft and haberdashery.
SK6 7AD · SK17 6BJ · SK8 1DR

WEST MIDLANDS



Coco Alpacas

www.cocoalpacas.co.uk
01694 724041

Coco is a small shop in Church Stretton, Shropshire that specialises in unique yarns, including our very own Coco Alpaca DK, locally produced yarn from our own herd of alpacas, in natural colours.



SOUTH



Handmade Studios

www.handmadestudios.org
02392 412901
Specialising in indie dyers like Baa Ram Ewe, Truly Hooked, Easy Knits, Unbelieva-wool and others.
Also monthly featured indie dyer.
Plus brands including Rowan, Debbie Bliss, Noro, WYS, Navia, Erika Knight and Alafosloppi.
4 The Green, Rowlands Castle, PO9 6BN

ONLINE

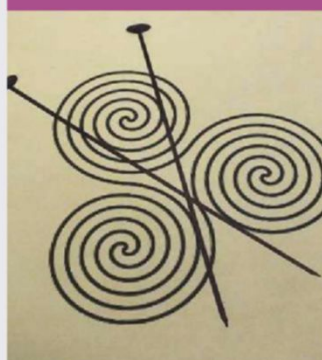

Arcane Wools

www.arcanewools.co.uk
arcanewools@gmail.com
07787 389595

Arcane Wools is a small wool shop in the Highland countryside filled with lovely yarns, knitting kits, patterns and accessories. Stockists include Debbie Bliss, Noro, Rowan, Regia Sock yarns, Araucania and DY yarns.
Workshops and tuition available.

TRY 3 ISSUES FOR JUST \$9.95*

when you subscribe today!



\$12.99
From
\$3.32
an issue!

Save over \$29 ON YOUR FIRST 3 ISSUES

- ⊕ Never miss an issue - 13 issues a year
- ⊕ Subscription prices inclusive of delivery ⊕ Free pattern booklet with every issue

US pricing

\$9.95 for your first 3 issues - SAVE 74%

After this pay just \$14.97 by 3-monthly continuous credit

\$49.95 1 year by credit/debit card (13 issues) - SAVE 70%

www.imsnews.com/theknitter-a041

or call toll free on 1 800 428 3003 and quote A041

Europe pricing

£76.99 - Credit/debit card 1 Year (13 issues)

Rest of the World pricing

£94.99 - Credit/debit card 1 Year (13 issues)

www.buysubscriptions.com/TKPOS16

or call +44 1604 973 760 and quote TKPOS16

Terms & conditions Terms & conditions *North American savings compared to buying 13 full priced issues at \$12.99 from the US newsstand. Europe and ROW have no set newsstand price and therefore we cannot advertise the specific savings you will make. If you subscribe by 3-monthly continuous credit card payments, you will be charged every 3 months until you cancel. Europe and ROW customers will be charged in GBP. North American subscribers will pay in US\$. This offer is for new print subscribers only. You will receive 13 issues in a year. Prices correct at point of print and subject to change. Prices correct at point of print and subject to change. If at any time during the first 60 days you are dissatisfied in any way, please notify us in writing and we will refund you all unmailed issues. Offer ends: 2nd May 2018

NEXT MONTH

Discover inspirational
patterns from
Emma Vining,
Jennie Atkinson,
Anniken Allis,
Lisa Richardson,
Sarah Hatton
...and more



Celebrate British wool
with **Sheepfold**,
and discover all the
new yarns for your
spring knitting



The Knitter



Missed an issue?

Catch up on what you've missed by downloading a back issue of *The Knitter* today

Issue 121

- ⊕ Slip stitch jumper
- ⊕ Cable sweater
- ⊕ Men's tank top
- ⊕ Colourwork cardigan
- ⊕ Wrap
- ⊕ Girl's dress
- ⊕ Faroese-style jumper
- ⊕ Beaded lace shawl
- ⊕ Granny square socks
- ⊕ Fair Isle cardigan
- ⊕ Ribbon wrap

SEE THE PATTERNS IN DETAIL HERE

<http://bit.ly/RAVTKN>

Issue 120



Issue 119



Issue 118



Issue 117



Issue 116



Issue 115



Issue 114



Issue 113



Issue 112



Issue 111



DIGITAL COPIES ARE AVAILABLE FROM ISSUE 11
Return to the app to buy issues 11 onwards

Once you've downloaded an issue, you can read it at any time

Abbreviations

alt	alternate	MB	make a bobble
approx	approximately	mrk	marker
beg	beginning	P	purl
ch	chain	patt	pattern(s)
cn	cable needle	PB	place bead
cont	continue	PFB	purl into front and back of stitch
dc	double crochet (US single crochet)	pm	place marker
dec	decrease (work two stitches together)	prev	previous
DK	double knitting	pssso	pass slipped stitch over
DPN	double-pointed needle	P2tog	purl 2 stitches together
dtr	double treble (US treble crochet)	P3tog	purl 3 stitches together
est	established	pwise	purlwise
fol	following	rem	remain(ing)
inc	increase	rep(s)	repeat(s)
K	knit	rev st st	reverse stocking stitch
KFB	knit into front and back of stitch	RH	right hand
K2tog	knit the next two stitches together	RS	right side
kwise	knitwise	skpo	slip 1, knit 1, pass slipped stitch over
meas	measures	sk2po	slip 1, knit 2 tog, pass slipped stitch over
M1	make one (see M1L)	s2kpo	slip 2 tog kwise, knit 1, pass slipped sts over
M1pw	make 1 st purlwise: with LH needle lift the strand between next and last st from front to back and purl through the back loop	Sl	slip
M1L	left leaning increase: with left needle tip, lift strand between needles from front to back. Knit lifted loop through back of loop	sl st	slip stitch
M1R	right leaning increase: with left needle tip, lift strand between needles from back to front. Knit lifted loop through front of loop	ss	slip stitch (crochet)
		slm	slip marker
		SSK	slip 2 stitches one at a time, return to LH needle, knit 2 slipped stitches together tbl
		SSP	slip 2 stitches one at a time, return to LH needle, purl 2 slipped stitches together tbl
		st(s)	stitch(es)
		st st	stocking stitch
		tbl	through back of loop
		tog	together
		tr	treble crochet (US double crochet)
		w&t	wrap and turn
		WS	wrong side
		wyib	with yarn in back
		wyif	with yarn in front
		yb	take yarn back (no inc)
		yf	bring yarn to front (no inc)
		yfwd	yarn forward
		yo	yarn over
		ym	yarn round needle



An archive of all our Masterclasses is available online: <http://bit.ly/tech-index>

Contacts

BOOK PUBLISHERS

Search Press

01892 510850
www.searchpress.com

Sixth & Spring

c/o The GMC Group
01273 488005
www.thegmcgroup.com

YARN SUPPLIERS

Bergère de France

www.bergeredefrance.co.uk

Erika Knight

c/o Thomas B. Ramsden
01943 872264
www.tbramsden.co.uk

Isager

<http://shop.isagerstrik.dk/>

Available in the UK from:
Oxford Yarn Store 01865 604112
www.oxfordyarnstore.co.uk

Jamieson & Smith

01595 693579
www.shetlandwoolbrokers.co.uk

Rennie

01771 622422
www.knitrennie.com

Rowan

01484 950630
www.knitrowan.com

Scheepjes

www.scheepjes.com/en
Available in the UK from:
Wool Warehouse 01926 882818
www.woolwarehouse.co.uk
Deramores
www.deramores.com

Yarn Stories

01484 848431
www.yarnstories.com

West Yorkshire Spinners

01535 664500
www.wyspinners.com

Pattern updates

Our archive of updates can be found at:
www.theyarnloop.com/magazine/the-knitter/corrections

ISSUE 120 Grisedale

The black dot symbol in the chart should say “knit on wrong side, purl on right side”. The red panel should come out in garter stitch.

ISSUE 121 Saltaire

Row 7 of the Scallop pattern should be worked in yarn B, not yarn A as printed.

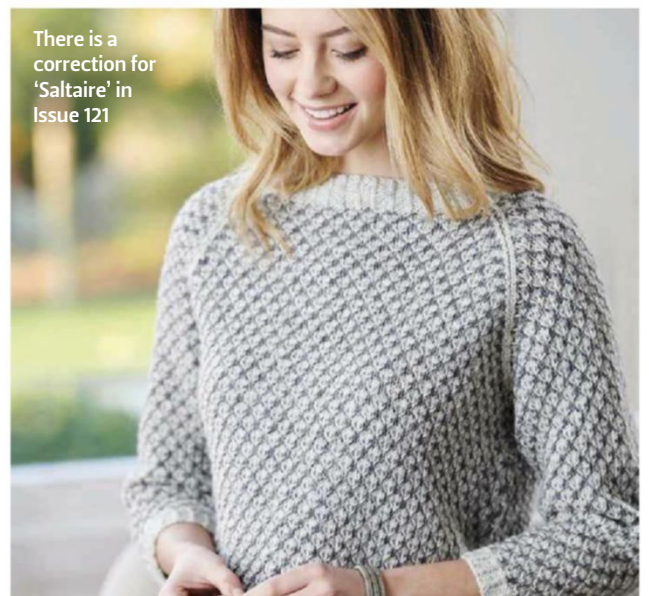

MY INSPIRATION

Karie Westermann

Karie's design work is characterised by delicate stitch patterns and elegant shapes



BORN IN Denmark and now based in Scotland, Karie Westermann is an inspirational designer and writer who has won many fans thanks to her elegant, thoughtful lace and colourwork patterns.

She has recently published her first book, *This Thing of Paper*.

Who inspired you to take up knitting?

"I was taught to knit and sew by my formidable great-grandmother Lilly, who brought up 18 children during the 1930s and 1940s in a cottage with no running water and no central heating system. She taught me that having the ability to make clothes gives you confidence in your ability to do many other things.

"I picked up knitting again when I fell very ill. I was stuck in bed for months – I could not read, watch TV or listen to the radio – and so we hit upon the idea of me knitting. I found that I had a knack for it, and before I knew what had happened, I was working for a yarn company!"

Do you have a favourite artist, writer, poet or musician who inspires you?

"David Bowie has influenced me for as long as I can remember. He kept pushing against boundaries, innovating, and asking questions. I look at Bowie and I know that creativity is boundless. It is possible to keep things fresh and you can draw inspiration from all sorts of things."

Which designer has most inspired you?

"I've been very lucky to work with so many inspiring people over the years, and I've learned so much from everyone. Working with Susan Crawford was especially inspiring because what she does is incredibly difficult. Susan understands dress history and textiles in a way that very few other knitting designers do, and she uses this detailed knowledge in her work in a seemingly effortless way. Yet when you

work with her, you learn just how much effort she puts into everything she does."

Tell us about the colours, landscapes or architecture that inspires your work.

"As a Scandinavian, I'm a big fan of clean lines, and I can spend a lot of time thinking about the right shade of off-white! But there is also the whole Scandinavian love of storytelling, and using craft to tell those stories. I looked at an old photo album the other day and I had to laugh when I saw all the amazing jumpers kids were wearing to school when I was young. There is a lot of continuity to Scandinavian knitting: it is traditional, but it is a living and breathing tradition. It's on the high street as much as it's in a textile museum."

What fibres do you love to work with?

"I like my yarns to tell a story – about where they are from, or who the dyer is. I prefer yarns that haven't been processed beyond recognition; I've worked a lot with yarns from The Island Wool Company and Blacker Yarns for that reason. However, I also love Rowan Kidsilk Haze (so versatile and makes even the simplest pattern shine) and hand-dyed silk blends from dyers like DyeNinja and Travelknitter."

Which design from your portfolio are you most proud of, or is most special to you?

"'Incunabula' from *This Thing of Paper*. I had a clear idea of what I wanted it to be like: a classic cardigan with small, clever details. We worked very hard on making the pattern accessible to people despite the many different details involved. It turned out even better than I had imagined."

Are there any techniques, traditions or styles of knitting you'd like to explore?

"I haven't done much with Estonian lace, and I know I want to play in that particular sandbox. The way they think about stitches and fabric is just so amazing." 🍷

www.kariebookish.net



❶ 'Alma's Song' uses a hand-dyed silk-blend yarn from DyeNinja ❷ 'Fika', from Karie's *The Hygge Collection* e-book ❸ David Bowie's creativity has long influenced Karie ❹ She is proud of her 'Incunabula' cardigan ❺ The 'Rubrication' shawl from *This Thing of Paper*

TERRY O'NEILL / GETTY IMAGES



World Craft Week

16 - 22 APRIL 2018

in support of

Bliss
for babies born
premature or sick

World Craft Week is back and this year we have teamed up with Bliss, the leading UK charity for babies born premature or sick.

Join us for a week celebrating craft and help us raise money for this important cause.

SIGN-UP NOW to find out how you can get involved plus you will receive a **FREE downloadable craft magazine** packed with beautiful baby projects.

Bliss Registered charity no. 1002973 Scottish registered charity SC040878



Sign-up now!
www.worldcraftweek.com



10% OFF*
Enter promo code
CSOFT10
when you checkout

Deramores
KNIT · CROCHET · CREATE

★ Earn points with
DERAMORES
Rewards

www.deramores.com



Pictured yarn - King Cole Cottonsoft Baby Crush DK Pinks, Blues. *When you spend over £15. Terms and conditions apply. Ends 31st May 2018.

Deramores Retail Ltd, Unit 1, Sabre Way, Peterborough, PE1 5EJ



Dario Tubiana

Monte Viso

Modern colour-block jumper has
unusual cables and mohair details



Dario Tubiana
Monte Viso

SIZE

	6-8	10-12	14-16	18-20	22-24	26-28	
TO FIT BUST	76-81	86-91	97-102	107-112	117-122	126-132	cm
	30-32	34-36	38-40	42-44	46-48	50-52	in
ACTUAL BUST	76	86½	97	107½	118	128½	cm
	30	34	38	42¼	46½	50½	in
ACTUAL LENGTH	70	75	74	76	78	80	cm
	27½	28	28½	29	29½	30	in
SLEEVE SEAM	50	50	50	52	52	53	cm
	19½	19½	19½	20½	20½	21	in

DARIO TUBIANA'S relaxed, modern sweater design is knitted in the round from the bottom up, then joined with the sleeves to work the yoke with its raglan decreases. The colour-block fabric is complemented by dimensional tuck cables, and small stripe details knitted in a fluffy mohair yarn. The main fabric uses Rowan's versatile Pure Wool Superwash Worsted yarn, which comes in 25 attractive colours.

SPECIAL TECHNIQUES

DIMENSIONAL TUCK CABLE

The central cable in the sweater is knitted using tuck stitches. As explained in Tracy Purtscher's book *Dimensional Tuck Knitting* (Sixth & Spring, 2017), this technique is very easy and intuitive.

For this cable you will have to purl two stitches, and after five rounds you will take them from the back of your work and you will pull them up and knit them together with another stitch in order to obtain a 3D effect on your sweater without crossing any stitch and avoiding using cable needles. Check the key under the chart.

BODY

Using 3.5mm circular needles, 60cm long and yarn A, cast on 154 (174:194:214:234:254) sts. Pm and join to work in the round, taking care not to twist sts.

Knit 14 rounds.

Using yarn D, knit 9 rounds.

Change to yarn B.

Next round: K73 (83:93:103:113:123), pm, K11 (16:21:26:31:36), pm, K10, pm, K8, pm, K23, pm, K8, pm, K10, pm, K to end of round.

Knit 5 rounds, slipping markers as you come to them.

Begin working Charts as follows:

Round 1: K73 (83:93:103:113:123) sts for Back, slm, K to mrk, slm, work Chart A to mrk, slm, K8, slm, work Chart B, slm, K8, slm, work Chart C, slm, K to end of round.

Work 50 more rounds in st st and Chart patterns as set.

Change to yarn A.

Work 45 rounds in st st and Charts as set.

Place sts on a holder or waste yarn.

SLEEVES

(both alike)

Using 3.5mm DPNs or circular needles 60cm long (for Magic Loop method) and yarn C, cast on 36 (38:38:40:42:46) sts. Pm and join to work in the round, taking care not to twist sts.

Knit 13 rounds.

Begin colourwork as follows:

Round 1: (K1A, K1C) to end of round.

Round 2: (K1C, K1A) to end of round.

Round 3: (K1A, K1B) to end of round.

Round 4: (K1B, K1A) to end of round.

Using yarn B, knit 8 rounds.

Using yarn D, knit 3 rounds.

Using yarn A, knit 2 rounds.

Using yarn D, knit 7 rounds.

SHAPE SLEEVE

Inc round: K1, M1L, K to last st, M1R, K1. 2 sts inc'd.

Continue in st st in yarn C until Sleeve meas 50 (50:50:52:52:53) cm, AT THE SAME TIME repeating the Inc round every 7th (6th:4th:3rd:3rd) round, 9 (10:9:6:12) more times, then every - (:5th:5th:5th:5th) round - (:5:10:6:6) times.

56 (60:68:74:80:86) sts.

When Sleeve meas 50 (50:50:52:52:53) cm, slip the 6 (6:7:7:9:9) sts each side of mrk onto a holder.

YOKE

With RS of Body facing, place first 6 (6:7:7:9:9) sts on to a holder, then using 3.5mm circular needles, 80cm long, and yarn C, pm, K61 (71:79:89:95:105) sts from Back, pm, place next 6 (6:7:7:9:9) sts on to a holder, pm, K44 (48:54:60:62:68) sts from Sleeve, pm, place first 6 (6:7:7:9:9) sts from Front on to a holder, work across 69 (79:87:97:103:113) sts, working Chart B as set and working st st over Charts A and C, pm, place rem 6 (6:7:7:9:9) sts of Front on to a holder, K44 (48:54:60:62:68) sts from second Sleeve, pm to mark beg of round. 218 (246:274:306:322:354) sts.

SHAPE YOKE

Dec round: K1, K2tog, K to 3 sts before mrk, S11 kwise, S11 pwise, slip first st over second slipped st, K1; rep from * 3 more times. 8 sts dec'd.

YARN

Rowan Pure Wool Superwash Worsted (Heavy DK/worsted weight; 100% wool; 200m/219yds per 100g ball)

A MAGENTA (119)	2	2	2	2	2	2	x100g BALLS
B GOLD (133)	2	2	2	2	2	2	x100g BALLS
C GRANITE (011)	3	3	3	4	4	5	x100g BALLS

Rowan Kidsilk Haze (Lace weight; 70% mohair, 30% silk; 210m/229½yds per 25g ball)

D WHITE (612)	2	2	2	2	2	2	x25g BALLS
----------------------	---	---	---	---	---	---	------------

Rep Dec round every 3rd round 4 (4:3:0:2:0) more times, every alt round 11 (14:18:25:25:31) times, AT THE SAME TIME, once Chart B repeat has been worked 9 (10:10:11:11:12) times, continue to work Front in st st only. 90 (94:98:98:98) sts. Cast off loosely.

I-CORD EDGING

With WS facing, beginning at a raglan 'corner' of the neck edge and picking up one stitch for every cast-off stitch, work as follows:

Using 4.5mm DPNs, 3 strands of yarn D held together and the thumb cast-on method, cast on 4 sts.

*K3, Sl1, pick up a stitch from the neck edge of the yoke and slip it onto the RH needle, SSK together the slipped stitch with the picked up stitch, pull yarn to back of needles and slide sts to other end of DPN; rep from * until you have worked around the entire yoke.

Repeat for hem and cuffs, picking up one stitch for every cast-on stitch.

FINISHING

Graft underarm sts using Kitchener stitch. Block gently to measurements, following any yarn care instructions on the ball band. ☺

NEEDLES & ACCESSORIES

3.5mm (UK 10-9/US 4) circular needles, 60cm long
3.5mm (UK 10-9/US 4) circular needles, 80cm long
3.5mm (UK 10-9/US 4) double-pointed needles (DPNs)
Two 4.5mm (UK 7/US 7) double-pointed needles (DPNs), for edging
Stitch markers, stitch holders
Cable needle (cn)

TENSION

19 sts and 24 rounds to 10cm over st st using 3.5mm needles. Charts A and C meas 3cm wide. Chart B meas 11.5cm wide.

YARN STOCKISTS

Rowan 01484 950630
www.knitrowan.com

ABBREVIATIONS

C10B: Slip 5 sts to cn at back of work, K5, K5 from cn.

C10F: Slip 5 sts to cn at front of work, K5, K5 from cn.

CHARTS

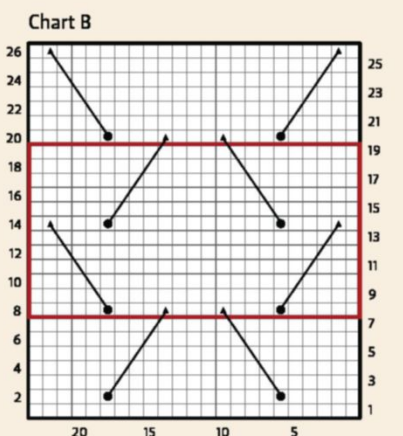
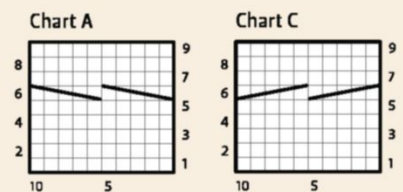

KEY

K on RS; P on WS P on RS; K on WS

Pick up the marked purl st from the WS of the work 6 rows below and Ktog with this stitch

C10B

C10F

Repeat



Central cables are worked using tuck stitches, without a cable needle

The white stripes
and i-cord edgings
are knitted in
a mohair yarn



The project is knitted
in the round, from
the bottom up



Meet Dario Tubiana

A rising star of Italian knitwear design, Dario loves to create fashionable, modern knits by playing with brioche, cables and Icelandic lopapeysa traditions



DARIO TUBIANA is a young Italian designer who has been wowing us with his modern interpretations of classic lopi sweaters,

and his creative ways with colourwork. He has been publishing his patterns on Ravelry only since 2016, but he is quickly developing into an exciting designer to watch.

Formerly a make-up artist in Milan, and a student of Christianity and contemporary Judaism, Dario learnt the basics of knitting as a child but, like so many of us, only began knitting seriously as an adult.

“Most of the sweaters I used to wear were hand-knitted by my

mum,” Dario recalls. “I always found it fascinating that she could create an entire sweater from a bunch of balls of yarn, and the fact that she used to knit made the whole thing even more magical, because I was seeing all the pieces becoming a garment overnight!

“I asked her to teach me, and she gave me some yarn and a pair of needles, and showed me what to do. I didn’t have much patience, though, so I gave up very soon. It was only many years later, after leaving university, that I found myself taking those same needles and asking my mum again to teach me again – and I have never stopped knitting since!”

As soon as he began to develop his skills and confidence, Dario started creating circular yoked sweaters for himself, both bottom-up and top-down – and before long, he

started designing them, too. “I am totally in love with lopapeysa sweaters, and my first original design was ‘Prismatic Dusk’, an Icelandic sweater with a circular yoke that I designed inspired by the dominant colours of the sunset,” he says.

Dario’s first pattern for *The Knitter* was a huge scarf called ‘Geometric Chaos’ – “so called because I designed it in brioche and used syncopated stitches in order to create a geometric shape,” he explains. “Brioche and colourwork knitting are definitely the two techniques I prefer the most! I knitted both ‘Prismatic Dusk’ and ‘Geometric Chaos’ in the summer – not the best season to knit such patterns – but despite the hot weather I could not detach myself from the projects. I wanted to finish them to see the final result, and I have to say I was rather chuffed at the end!”

Dario is strongly influenced by architecture when creating stitch patterns and shapes for his work. “I like geometric shapes, and I like walking around looking at buildings and watching construction projects, and seeing how they match one another, or how they even overlap.

“In terms of finding inspiration for colours, though, the story is a little different. Here in Italy, it still happens that people, after washing their clothes, hang them outside the window to dry. Well, when people do that they inadvertently create wonderful colour palettes! You can see hanging together one red T-shirt, one blue towel, two pink skirts and one yellow cardigan. Well, that’s a palette! It’s certainly a fun way to find ideas of what colours you’d like to use, and which colours look good together!”



‘Geometric Chaos’ is a brioche scarf designed for *The Knitter* issue 116

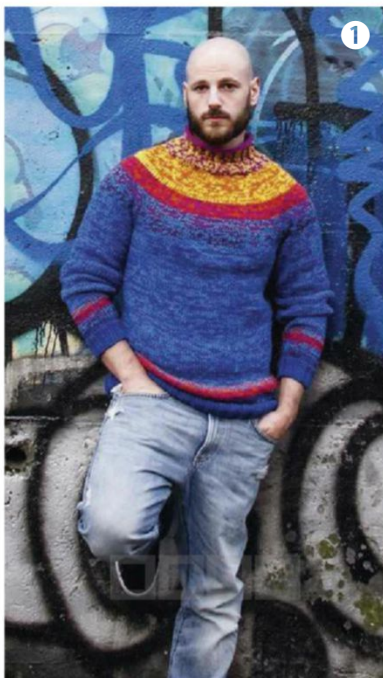



2

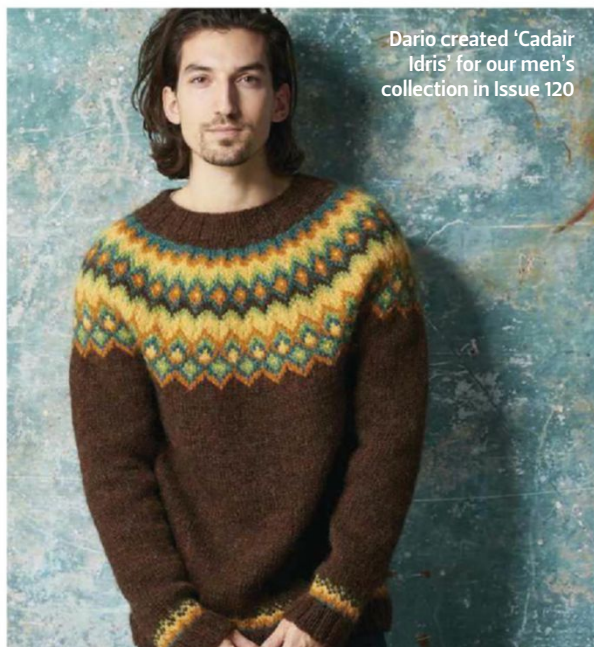

Dario created 'Cadair Idris' for our men's collection in Issue 120



3



4



'Glory' combines colour-block stripes and cables

1 'Hinomaru Sweater' has speckled stripes created by knitting different coloured yarns together 2 'Thorri' from *The Knitter* 121 3 'Daphnee' has a pretty stranded yoke 4 Dario's top-down 'Twilight Zone' design



'Prismatic Dusk' was Dario's first-ever design

As well as the shapes and colours around him in his native Italy, Dario has been inspired by the New York-based design team Spencer Vladimir, known for its fashion knitwear. "I just love their cables, their sweaters, their ideas and collections. They manage to take a classic sweater and make it new and fresh." He also cites the work of Britt-Marie Christoffersson in her book, *Pop Knitting*: "It's a great book for gathering new ideas and get inspiration when you want to do something a little bit 'out of the box!'"

Dario's first two sweater designs for *The Knitter*, 'Cadair Idris' and 'Thorri',

both used Lopi wool from Iceland, as it is his favourite yarn to work with. "I just love it!," he says. "Unfortunately, it's extremely hard to find it here in Italy. So every time I want some, I have to order it from Iceland, or buy some whenever I travel outside of Italy (an awesome excuse to travel!). Besides Icelandic wool, I also love to knit with alpaca and Shetland wool. I have some yarn that was given to me for my birthday, so today I'm busy making a yoked bottom-up sweater. I recently moved up north in Italy, and it's very cold up here compared with Rome, so I do need some warm knits!"

So, what's next for this adventurous designer? "I am very curious about Portuguese knitting. I tried to use this technique a couple of times and I had so much fun, but I never really felt confident enough to use it for an entire garment. I'll definitely use it when I design a garment knitted entirely in reverse stocking stitch, since it's a very convenient technique for purling. And isn't that way of making the yarn go around your neck super-cool?" ☺

Find all of Dario's knitting patterns at www.ravelry.com/designers/dario-tubiana---rossocardinale



The
Knitter