

**+ WIN!**  
£499 SEWING PRIZES\*

**PLUS** SEW YOUR OWN  
GYM ACCESSORIES

# Simply Sewing



FRESH IDEAS WITH FABRIC

ISSUE THIRTY EIGHT



**BALLERINA  
PLUSHIE**  
FOR PLAYTIME

**24 PROJECTS TO MAKE**  
**EASY-WEAR**  
**ALICE DRESS**  
**IN SIZES 6-20**



**STITCH A NEW  
WARDROBE!**



# FLATTER & FIT

Relaxed fabrics & styles for everyday wear

\*UK ONLY - RULES APPLY

**HOW TO:** Sew with cork • Upcycle old jumpers • Denim skirt • Bag-making • Mitred borders



## Innov-is F420

The Innov-is F420 is packed with a huge range of features including 140 stitches, lettering, lock stitch button, automatic thread cutter, and Square Feed Drive System for strong, smooth, even sewing on all types of fabric.



## Innov-is 55FE

The feature-packed Innov-is 55 Fashion Edition will shape your fashion dreams into reality. 81 stitches including 10 one step button hole styles plus lettering together with the included 12 accessory feet make this an excellent all round machine.



## Innov-is 27SE

The Innov-is 27SE offers fantastic versatility for both the beginner and experienced sewer. With fingertip controls, 50 stitches including 5 one step button hole styles and a protective hard case; it's ideal for all kinds of sewing.

# Create your own style



# Simply Sewing

FRESH IDEAS WITH FABRIC

New year, new handmade wardrobe! That's our first stitching resolution for 2018 and we've got some amazing garments to keep us all on track.

The Alice Dress is an easy-to-wear wrap-style design, which is quick to sew and ideal for beginners. There's also a sweet blouse to stitch with a bow detail and a denim skirt that you'll never believe is made from an old pair of jeans.

And when you're not working on your new attire, you can brush up on your bag-making skills with our floral gym bag and cork clutch, or whip up Jo Carter's tutu-clad ballerina for a little one... or yourself! Happy stitching to all.



# Simply Sewing

FRESH IDEAS WITH FABRIC

## ISSUE THIRTY EIGHT CONTENTS

Make a thrifty dog-shaped doorstop, p71



Sew The Alice dress, p34



♥  
P20  
GYM  
ACCESSORIES  
IN PRETTY FLORALS



### GREAT PATTERNS FOR YOU

### HOW TO...

**52** BE INSPIRED BY ROSIE MARTIN'S PASSION FOR PATTERN-FREE FASHION



- 20 CHIC GYM ACCESSORIES
- 34 PATTERN: THE ALICE DRESS
- 38 REFASHION: DENIM SKIRT
- 45 CORK CLUTCH BAG
- 47 QUICK FIX: SNUGGLY COWL
- 48 PATTERN: THE BEA BLOUSE
- 57 QUICK-SEW SLEEP MASK
- 67 DENIM UPCYCLE: POCKET ORGANISER WALL HANGING
- 69 RAINDROP CUSHION
- 71 FAST FAT QUARTER: DOORSTOP
- 78 LAUNDRY DAY SET
- 84 BALLERINA TOY
- 89 TRANSFORM IT: KID'S POCKET JUMPER DRESS

- 59 EMBROIDERY: BULLION ROSE  
Stitch a romantic heart for Valentine's
- 73 WORKSHOP: MITRED BORDERS  
Learn the technique and make a set of coasters
- 93 SEWING GUIDE  
Tips, techniques and a glossary



Stitch a toy ballerina for playtime, p84



69



33



45



1

**WIN!**  
**SEWING BOOKS & STASH WORTH £499**  
 Your chance to win new books, fabric bundles and more!  
 Turn to p17



38

**HIT REFRESH...**

A new year calls for a new wardrobe and we've got the patterns to make it happen! The Alice Dress (p34) is one of my personal faves. It's quick to sew and made up in versatile jersey for a relaxed style – a pattern I'll be making over and over again. Try our chic Bea Blouse (p48) too, or fashion a denim skirt from a pair of jeans (p38), get gym-ready by stitching your own pretty accessories (p20) and brush up on your appliqué with our fun raindrop cushion (p69). We've even given laundry day a makeover (p78). Enjoy!

*Nikki*  
 Nikki Morgan, Acting Editor



89

**GOOD READS & IDEAS**

- 9 PINBOARD: Ideas, events, new fabric
- 15 SEWING QUARTER: STITCHING BOOKS ROUND-UP
- 17 WIN: FABRIC, BOOKS & MORE
- 33 PIN UP: THE GYM BAG
- 42 COLUMN: BY HAND LONDON
- 52 PROFILE: ROSIE MARTIN
- 62 FEATURE: BY WAY OF BLOG
- 97 COMING UP NEXT MONTH
- 98 MY FAVOURITE THING



**GREAT SUBS OFFERS! P18**  
 SAVE TIME, MONEY AND HASSLE WITH AN ANNUAL SUBSCRIPTION

\* FREE PATTERNS ONLY AVAILABLE ON UK NEWSSTAND

# CONTRIBUTORS

A huge thank you to this clever bunch...



## MOLLIE JOHANSON

Mollie Johanson is the author of *Stitch Love: Sweet Creatures Big & Small*. She lives near Chicago and is happiest with a cup of tea and some stitching. Try her bullion rose tutorial on page 59 and make a hanging heart ornament.



## TORIE JAYNE

Torie Jayne is a blogger and craft author based in Devon, England. She shares her craft, baking and interior design projects at [www.toriejayne.com](http://www.toriejayne.com). Sew a laundry day set from her *Stylish Home Sewing* book with her how-to on page 78.



## LOUISE ORTH

Louise has been sewing since early 2012 and co-runs a quilting subscription business, the Modern Quilter's Box. She sews everything from patchwork quilts to zip pouches and bags. Make her Liberty-lined cork clutch bag on page 45.



## BY HAND LONDON

By Hand London is a London-based independent pattern label run by Elisalex and Charlotte, who design sewing patterns inspired by the stylish ladies they admire. They share their sewing resolutions for the new year on page 42.

## OTHER CONTRIBUTORS

Jo Carter, Jessica Entwistle, The Fold Line, Debbie von Grabler-Crozier, Jennie Jones, Portia Lawrie, Dara Magagnoli, Rosie Martin, The New Craft House, Jenni Smith  
Special thanks to: Annelise Brant

[WWW.SIMPLYSEWINGMAG.COM](http://WWW.SIMPLYSEWINGMAG.COM)

[facebook.com/simplysewingmagazine](https://www.facebook.com/simplysewingmagazine) [twitter.com/SimplySewing](https://twitter.com/SimplySewing) [pinterest.com/simplysewingmag](https://www.pinterest.com/simplysewingmag) [instagram.com/simplysewingmag](https://www.instagram.com/simplysewingmag)

### COMPETITION RULES

By taking part in one of our Competitions, you agree to be bound by these Competition Rules. Late or incomplete entries will be disqualified. Proof of posting (if relevant) shall not be deemed proof of delivery. Entries must be submitted by an individual (not via any agency or similar) and, unless otherwise stated, are limited to one per household. The Company reserves the right in its sole discretion to substitute any prize with cash or a prize of comparable value. Unless otherwise stated, the Competition is open to all GB residents of 18 years and over, except employees of Immediate Media Company and any party involved in the competition or their households. By entering a Competition you give permission to use your name, likeness and personal information in connection with the Competition and for promotional purposes. All entries will become the property of the Company upon receipt and will not be returned. You warrant that the Competition entry is entirely your own work and not copied or adapted from any other source. If you are a winner, you may have to provide additional information. Details of winners will be available on request within three months of the closing date. If you are a winner, receipt by you of any prize is conditional upon you complying with (among other things) the Competition Rules. You acknowledge and agree that neither the Company nor any associated third parties shall have any liability to you in connection with your use and/or possession of your prize. Competition open 28 December 2017 - 1 February 2018

# Simply Sewing

FRESH IDEAS WITH FABRIC

## EDITORIAL

ACTING EDITOR Nikki Morgan  
ART EDITOR Lisa Jones  
TECHNICAL EDITOR Rebecca Reid  
PRODUCTION EDITOR Michelle Grady  
DIGITAL EDITOR Zoe Williams  
FEATURES WRITER Judy Darley  
PHOTOGRAPHY Philip Sowels, Jesse Wild, Dave Caudrey

## ADVERTISING

Call 0117 300 8206  
SENIOR ADVERTISING MANAGER Penny Stokes  
SENIOR SALES EXECUTIVE Tiffany Jackson  
CLIENT PARTNERSHIP MANAGER Beckie Pring

## MARKETING & CIRCULATION

SUBSCRIPTIONS DIRECTOR Jacky Perales Morris  
DIRECT MARKETING EXECUTIVE Lily Nguyen  
HEAD OF NEWSTRADE MARKETING Natalie Shearer  
NEWSTRADE MARKETING MANAGER Janine Smith

## BUYING

Paul Torre, Karen Flannigan, Corinne Mellerup

## PRODUCTION

JUNIOR PRODUCTION COORDINATOR Lily Owens Crossman  
PRODUCTION MANAGER Sian Rodgers / Emma McGuinness  
PRODUCTION DIRECTOR Sarah Powell

## LICENSING

DIRECTOR OF INTERNATIONAL LICENSING & SYNDICATION MANAGER  
Tim Hudson [tim.hudson@immediate.co.uk](mailto:tim.hudson@immediate.co.uk)  
INTERNATIONAL PARTNERS MANAGER  
Anna Brown [anna.brown@immediate.co.uk](mailto:anna.brown@immediate.co.uk)

## PUBLISHING

PUBLISHER Liz Taylor  
CHIEF EXECUTIVE OFFICER Tom Bureau  
MANAGING DIRECTOR, BRISTOL Andy Marshall

## DISTRIBUTION

FRONTLINE Call +44 (0)1733 555161

## PRINTED IN THE UK

BY WILLIAM GIBBONS

## NEED TO GET IN TOUCH?

EDITORIAL TEAM  
[simplysewing@immediate.co.uk](mailto:simplysewing@immediate.co.uk)  
SUBSCRIPTIONS TEAM  
[simplysewing@buysubscriptions.com](mailto:simplysewing@buysubscriptions.com)  
03330 162 149

## NEXT ISSUE ON SALE

THURSDAY 25TH JANUARY 2018

No gift included? Ask your newsagent.  
Covergift may be unavailable overseas.

# IMMEDIATE MEDIA CO

Immediate Media Company Bristol Limited (company number 05715415) is registered in England and Wales. The registered office of Immediate Media Company Bristol Limited is at Vineyard House, 44 Brook Green, London W6 7BT. All information contained in this magazine is for information only and is, as far as we are aware, correct at the time of going to press. Immediate Media Company Bristol Limited cannot accept any responsibility for errors or inaccuracies in such information. Readers are advised to contact manufacturers and retailers directly with regard to the price of products/services referred to in this magazine. If you submit unsolicited material to us, you automatically grant Immediate Media Company Bristol Limited a licence to publish your submission in whole or in part in all editions of the magazine, including licensed editions worldwide and in any physical or digital format throughout the world. Any material you submit is sent at your risk. Although every care is taken, neither Immediate Media Company Bristol Limited nor its employees agents or subcontractors shall be liable for loss or damage.



When you have finished with this magazine please recycle it.

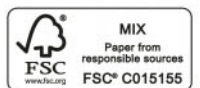

Ponte Roma - Boiled Wool - Lambswool - Chambray  
New Patterns - Art Gallery Knits - Double Cloth



**DRAGONFLY FABRICS**  
Modern Dressmaking Fabrics

**Free Postage**  
Code 'NEWYEAR'  
Expires 20/01/2018  
UK Only

**Christmas and New Year Specials**  
[www.dragonflyfabrics.co.uk](http://www.dragonflyfabrics.co.uk) Tel 01892-731087

# Simply Sewing

FRESH IDEAS WITH FABRIC

Simply Sewing is a magazine that is creative and innovative, inspiring yet practical - it's both a teacher and a friend to our readers.



TO LEARN MORE ABOUT ADVERTISING OPPORTUNITIES

PLEASE CONTACT TIFFANY JACKSON

TIFFANY.JACKSON@IMMEDIATE.CO.UK  
0117 300 8203

yarn fabric needles & hooks haberdashery buttons ribbons



All 342 shades in stock!

**£2.24**  
per fat quarter

Robert Kaufman:  
Kona Solids

Get **10% OFF EVERYTHING!**  
Discount code **SS38**

**£3.99**  
per fat quarter

Liberty Fabrics:  
The English Garden Collection

We're proud to stock all these leading brands!

All 286 shades in stock!

**£1.99**  
per fat quarter

Michael Miller:  
Magic Collection

Moda:  
Bella Solids

**£3.69**  
per fat quarter

**£1.69**  
per fat quarter

Rose & Hubble:  
Cotton Poptins

**FREE UK DELIVERY**  
on orders over £25

[www.woolwarehouse.co.uk](http://www.woolwarehouse.co.uk)  
01926 882818 or 0800 505 3300 | [hello@woolwarehouse.co.uk](mailto:hello@woolwarehouse.co.uk)

No minimum order. £2.95 delivery charge for UK orders under £25.  
\* Discount code not valid on sale items.

132 PAGES OF ON-TREND CROCHET AND NEW TECHNIQUES

*Mollie*  
MAKES

107 GIFTS, GARMENTS, PATTERNS  
& TECHNIQUES TO HOOK UP

# CROCHET

HOME • FASHION • QUICK MAKES • AMIGURUMI • GIFTS

TOP DESIGNERS  
FLAX & TWINE  
HANJAN CROCHET  
ILARIA CALIRI  
KAT GOLDIN  
REDAGAPE

36 FRESH PROJECTS

INSIDE: STEP-BY-STEP PATTERNS • BEGINNER'S HOW TO

JUST  
£8.99!\*



The team behind *Mollie Makes* bring you a collection of contemporary crochet patterns for **enthusiasts of all levels**. Our easy-to-follow projects created by **top crochet designers** will inspire you to hook clothes, gifts, home accessories and more. Plus there's a handy **beginner's guide** so you can start right away!

**ORDER YOUR COPY TODAY!**

Call 03330 162 138 AND QUOTE 'MOLLIE MAKES CROCHET 2018 PRINT 1'

Online [WWW.BUYSUBSCRIPTIONS.COM/CRAFTSPECIAL](http://WWW.BUYSUBSCRIPTIONS.COM/CRAFTSPECIAL)

Lines open weekdays 8am to 6pm and Saturday 9am to 1pm. Overseas please call +44 (0) 3330 162 138.

\* EUR price £11.99, ROW price £12.49. All prices include P&P. Please allow up to 28 days for delivery.

# PINBOARD

IDEAS ♡ INSPIRATION ♡ ACCESSORIES ♡ WEBSITES ♡ EVENTS ♡ STUFF



© Orageuse 2017 - Photo: A. Lamachère

## ALL DRESSED UP

French pattern brand Orageuse are proving that sleek tailoring isn't just for the office with their new Muse collection, which reworks classic masculine shapes into oh-so-chic feminine styles for work or play with an on-trend sports-luxe twist. The Bristol dress' versatile silhouette and unique button-and-bow neckline had us adding it to our basket straight away (yes, we *do* need another dress pattern!). See more at [www.orageuse.com](http://www.orageuse.com)



## IN-THE-KNOW KNITS

If mastering sewing with knits is one of your New Year's resolutions, you'll be able to tick it off in no time thanks to *A Beginner's Guide to Sewing with Knitted Fabrics* by Wendy Ward, featuring 20 easy-wear jersey basics to sew (and all on your regular sewing machine!). £12.99, [www.rylandpeters.com](http://www.rylandpeters.com)



## GYM BUNNY

Whether you're a regular gym-goer or are starting a class in the new year, it's time to upgrade your gear with this issue's gym bag pattern (p33) and workout accessories (p20). Try adding colour to your kit with this bright pink cotton strap by Prym – it's durable, hard-wearing and guaranteed to have you looking forward to your next gym session (well, maybe). £5.99, [www.sewingquarter.com](http://www.sewingquarter.com)



## COSY COOL

We've cosied up our fabric stash with ponte romas, sweatshirt knits and jerseys for winter-ready sewing and we're on a mission to add some snuggly me-mades to our wardrobe, starting with Nina Lee's new Southbank sewing pattern, which can be made as a dress, top or sweater. With its slouchy fit and funnel neck, it's our perfect winter warmer! Printed pattern £14, PDF £8.50, [www.ninalee.co.uk](http://www.ninalee.co.uk)

## A CUT ABOVE

Get your snips at the ready and celebrate the art of paper-cutting with these new cotton and canvas prints by Rashida Coleman-Hale for Cotton + Steel. Rashida was inspired by the Japanese festival of Tanabata, also known as the Star Festival, when strips of coloured paper with wishes written on them are hung from bamboo branches, and Kirigami, a type of origami that involves cutting paper. Florals, toami (a traditional paper cut of a finishing net), scissors, geometric shapes and stars feature in a zingy colour palette of coral, mustard and teal, with most printed on unbleached fabric for a vintage paper look. [www.cottonandsteelfabrics.com](http://www.cottonandsteelfabrics.com)



Pull some shapes (and we don't mean on the dancefloor) with these papercut prints.

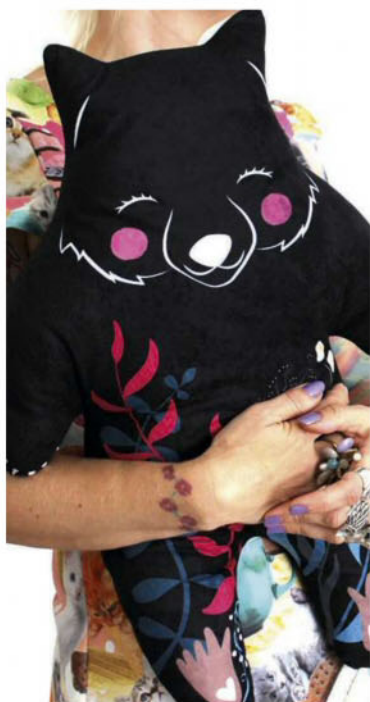

**MINI PROFILE**  
**MISS ELLA**

Ella Goodwin's illustration style is a mixing pot of gloriously whimsical influences, ranging from

fairytales, fantasy and sci-fi to the natural world – or, more specifically, wombats, cats and capybaras. The resulting collection is irresistibly quirky and brighten-your-day colourful, with cards, prints, jewellery and books, as well as make-it-yourself kits.

Ella has always taken a unique approach to fashion. "As an only child, I was always into making things. I would buy old curtains and make them into dresses to complement my hippy-goth attire of the time!" Ella put this creative streak to good use studying fashion and costume, and a London-based career in costume-making followed. Soon, though, she was itching to learn new skills. "From hand-stitching I moved to learning to digitise for computer embroidery." Her interest in the digital world piqued, she went on to study, and later teach, graphic design and animation at Norwich University of the Arts, leaving in 2012 to launch her own Etsy shop. This finally gave her the opportunity to "combine all of my skills selling my illustrations in the form of prints, cards, DIY fabric kits, paper kits, books, dolls, homewares and jewellery."

Ella's love of fairytales comes through in her designs, which are created with characters and stories in mind. "My process starts with sketches and often I'll write the characters

stories too as they come to life. Many of my doll kits come with their own mini books telling the tale of their lives so far. I like the fact it gives them more depth but lets the person making them continue the story." After the initial sketches, "I'll use a mix of materials but then finish the final illustration digitally. For the designing of the dolls, I'll use old scraps of fabric and draw over it with felt tips to design them, and then trial them on my trusty Brother industrial sewing machine before having them digitally printed."

Her most recent venture brings together her two loves: sewing and storytelling. "This year I wrote, illustrated and self-published a little book called *NeedleFeet and The Land of Doo*, a fairytale in a fantasy land of sewing materials. These themes always crop up in my work so I have plans to take the mini books that come with my dolls and build them into bigger picture books." She has plenty in the pipeline for fans of her animal kits, too: "I also have new fox and badger kits on the horizon for the constantly growing menagerie!"

See more at [www.missella.co.uk](http://www.missella.co.uk)

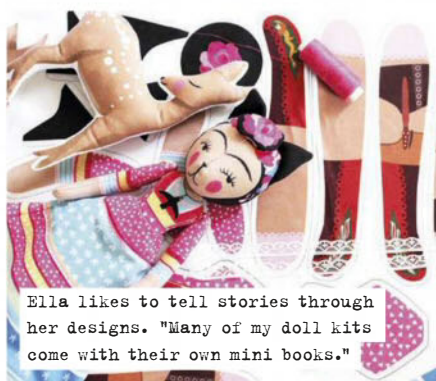

Ella likes to tell stories through her designs. "Many of my doll kits come with their own mini books."

**INSPIRING BOOKS**



**COLORING WITH THREAD**

Tula Pink (£16.99, Krause Publications)

Colour queen Tula Pink is known for her ornate prints, and has now forayed into the world of embroidery to offer stitchers the chance to recreate her signature designs with a needle and thread. The book has 17 designs from her best-selling fabric collections to embroider, with step-by-steps for over 20 stitches. [www.krausebooks.com](http://www.krausebooks.com)



**SEW YOUR OWN ACTIVEWEAR**

Melissa Fehr (£16.99, SewandSo)

Whether you're a runner, gym bunny or just a fan of leggings for lounging in, you'll be inspired to add to your activewear collection with this book by marathon runner, blogger and pattern designer Melissa Fehr. Take your pick from 13 styles, and swat up with tips for working with performance fabrics. [www.sewandso.co.uk](http://www.sewandso.co.uk)

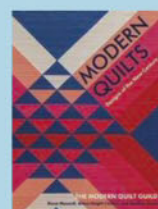

**MODERN QUILTS: DESIGNS OF THE NEW CENTURY**

Modern Quilt Guild (£33.99, Stash Books)

This collectible hardcover book celebrates modern quilting with photographs of over 200 quilts curated by The Modern Quilt Guild. Learn about the hallmarks of the genre, which is characterised by large-scale piecing, plain fabrics and bold colours. [www.ctpub.com](http://www.ctpub.com)



**A BEGINNER'S GUIDE TO DYEING AND SEWING**

Clémentine Lubin (£12.99, Search Press)

Refresh existing homewares and garments and learn how to dye fabric for your own creations with this beginner's guide to dyeing techniques. Try the 12 dye effects that are covered in the book, and then put them into practice with the 21 sewing projects that showcase the best ways to use them. [www.searchpress.com](http://www.searchpress.com)



## WORK YOUR MAGIC

▼ Transforming a piece of fabric into something beautiful to brighten up our home or wardrobe is our signature magic trick, so we'll be jazzing up our winter coat and wearing our stitching powers with pride with this little star-motif enamel sewing machine pin in so-Instagrammable rose gold, exclusive to Sew Crafty. Got yours? Pin it to your latest me-made and tag a snap with #showcrafty. £7.50, [www.sewcraftyonline.co.uk](http://www.sewcraftyonline.co.uk)



## MOON RIVER

Jersey dresses are our go-to on those not-sure-what-to-wear days, and Cashmerette has your throw-on-and-go style sorted with this Rivermont design. Pick from a fitted sheath dress with slash pockets and kick pleat, and a curve-loving peplum top, both with three sleeve lengths. Available in sizes 12 to 28 with three cup sizes (C/D, E/F, G/H). Printed pattern approx £14, PDF approx £11, [www.cashmerette.com](http://www.cashmerette.com)



## DISHING UP

If you want to know how much stitching we've done, just take a look at our craft room – a messy sewing space is a sure sign of a productive day! So we're hoping that keeping these little dishes next to our machine will help us to avoid the chaotic 'craftermath'. They're ideal for keeping haberdashery organised for a super-neat sewing table (just don't look in our fabric-stash drawer, ok?). From £3.95, [www.dotcomgiftshop.com](http://www.dotcomgiftshop.com)

## 3 OF THE BEST

### WOOD WOW

Move aside, marble – there's a new texture in town! Wood has had a pastel-hued, geometric-shaped makeover and is ready for its Instagram close-up.

1. Get some wood on your wall without having to get your DIY on with this modern print by graphic designer Marion Eijkenaar. £13, [www.yeswood.etsy.com](http://www.yeswood.etsy.com)
2. This thread-wrapped bangle has impressive eco credentials – it's made from vintage threads and reclaimed pine. £21, [www.vivilakedesign.etsy.com](http://www.vivilakedesign.etsy.com)
3. We didn't know it was possible for a candle holder to tick so many trend boxes – Scandi cool, minimalist style, pastel colours, geometrics – but this one nails them all. £25, [www.polymorphics.etsy.com](http://www.polymorphics.etsy.com)





## STRONG SUIT

We'll never see suits in the same way after The Refashioners 2017. This year saw Makery's Portia Lawrie challenge the online sewing community to transform a suit, and the results have had us raiding the menswear section. The winner was Toya, who made a sassy jacket, skirt and top combo, and even found time to make children's clothes from an old linen suit, too. Find her at [www.instagram.com/madebytoya](http://www.instagram.com/madebytoya)

## WILD ONE

The pretty wildflower print on this colourful nesting tin set may have been inspired by foraging in nature, but we have a different sort of foraging in mind for them – they're just the thing for storing all of our latest haberdashery finds! There's a matching toolbox ideal for our sewing kit, too. As if we needed an excuse to add to our collection of ribbons, buttons, embellishments and trims... Tins £15, [www.magpieline.com](http://www.magpieline.com)



The only treats we'll be keeping in these tins are sewing goodies!

## OUT & ABOUT

# SKILLS, SHOWS & EVENTS

### 20 JANUARY

Silk Ribbon Embroidery. Hangstones Pavilion, Yatton. Join bridal atelier Lisa Keating for this three-hour workshop on silk ribbon flower embroidery. [www.lkbespokebridal.co.uk](http://www.lkbespokebridal.co.uk)

### 24-26 JANUARY

Spring Quilt Festival, Ardingly. Get started on a new year of crafting with inspiring displays from well-known quilters and stash-boosting stalls. [www.grosvenorshows.co.uk](http://www.grosvenorshows.co.uk)

### FROM 1 FEBRUARY

Screen Printing For Textiles. Leeds Print Workshop. Learn the basics of screen-printing onto textiles and produce a range of textile samples at this five-week evening class. [www.leedsprintworkshop.org](http://www.leedsprintworkshop.org)

### UNTIL 18 FEBRUARY

Balenciaga: Shaping Fashion. V&A, London. An exhibition celebrating the work of Spanish couturier Cristóbal Balenciaga, with over 100 pieces on display. [www.vam.ac.uk](http://www.vam.ac.uk)

## 5 FAB FINDS

### Skills-boosting kits

Have a crafty start to the new year and give new techniques a try with these beginner kits.



#### SMITTEN KITTEN

Have a craft afternoon with a budding stitcher and help them make their own felt feline.

£8.95, [www.dotcomgiftshop.com](http://www.dotcomgiftshop.com)

#### ALL WRITE NOW

This calligraphy intro kit will help you perfect your penmanship and comes in a dip-dye canvas bag. Approx £77, [www.ashbushink.etsy.com](http://www.ashbushink.etsy.com)



#### WORK THE LOOM

Learn to loom with this starter pack ideal for weaving newbies. Loom-ing marvellous! From £29, [www.thesquidinkco.etsy.com](http://www.thesquidinkco.etsy.com)



#### WHY KNOT?

Try the macramé trend with a chic plant hanger – you won't get tied up in knots with this easy starter kit. £8.99, [www.prettylittleknotsco.etsy.com](http://www.prettylittleknotsco.etsy.com)



#### SO GLOVED UP

Keep cosy (and still use your phone) with knit-them-yourself fingerless gloves with two colour options. £18, [www.made.com](http://www.made.com)





## CHECK MATE

Look to the Scottish Highlands for your next project with this kilt pattern by Folkwear. It includes a kilt and kilt skirt, plus a jacket and vest for the full ensemble. We love the skirt's versatile midi length – and you'll be stitching pleats like a pro after finishing this skills-boosting project! £15, [www.folkwear.com](http://www.folkwear.com)

## STAR QUALITY

▼ DIY the star-motif trend with these lace zips, which can be sewn on the outside of your clothing and accessories projects for a statement look. They are available in a rainbow of colours – add one to a plain dress if all-over stars aren't your thing, or go intergalactic and use one to fasten up a cosmic-print frock. For stockists visit [www.hantex.co.uk](http://www.hantex.co.uk)



## EVERYDAY TAILORING

We've been searching for the perfect pair of trousers for years, but now we can stop searching and start sewing – Closet Case Files has the tailored-fit pair our wardrobes have been waiting for. With classic details, an easy-wear mid-rise, tapered leg and two views to choose from, the Sasha trousers are smart enough for the office but comfy enough for weekend brunch dates. Printed pattern approx £14, PDF pattern approx £11, [store.closetcasepatterns.com](http://store.closetcasepatterns.com)



## NEW AND IMPROVED

Megan Nielsen's latest pattern is an updated version of an out-of-print design, given a makeover with new versatile variations. The Banksia Blouse, one of Megan's first patterns, now includes a simple scoop neckline, neat button placket or pretty Peter pan collar – we're planning on making all three! PDF pattern approx £10, [www.megannielsen.com](http://www.megannielsen.com)

## LIBERTY CORNER

## LITTLE PRETTIES

Eléonore Estadiou is all about celebrating life's simple pleasures, from good food to beautiful fabrics; as well as being a food blogger, she also makes and sells colourful accessories for everyday living, from zip pouches and totes to bread bags and bibs, all made using high-quality fabrics, including gorgeous Liberty florals. From £7, [www.lafourmiele.etsy.com](http://www.lafourmiele.etsy.com)



Enjoy Liberty living with these practical accessories.



# Sewing QUARTER

WATCH IT • LOVE IT • SEW IT

Sewing Quarter is the only channel dedicated to all things sewing. Watch it live on Freeview channel 78 and buy online at [www.sewingquarter.com](http://www.sewingquarter.com)

## CREATIVE LIBRARY

Get your sewing year off to a flying start by stocking your craft shelves with stitch-themed books that will encourage and nurture your sewing skills and inspire your future makes. Our round-up covers topics such as DIY homewares, dressmaking, upcycling and alterations by some of the industry's biggest names, as well as from our very own *Simply Sewing* contributors, but they are just a few examples of the sewing titles you can get your hands on at Sewing Quarter right now. Head to the book section on the website to browse the full range and quote code SS2018 to receive 20% off your first order.

All available at [www.sewingquarter.com](http://www.sewingquarter.com)



### FAT QUARTER HOME

Amanda Russell and Juliet Bawden, £12.99

This beginner-friendly book is packed with clever projects and tips for how to turn fat quarters and scraps of fabric from your stash into decorative and useful items for your home.

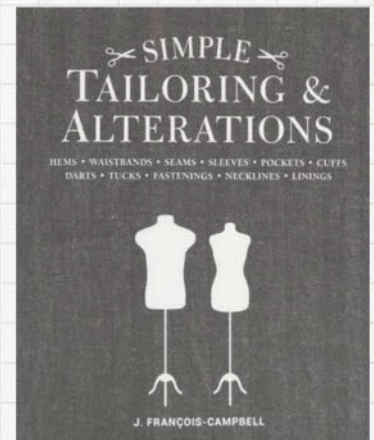

### SIMPLE TAILORING & ALTERATIONS

J. Francois-Campbell, £14.99

Revamp your wardrobe and maximise its usage with this practical guide to maintaining and altering your clothes. Projects include: dresses, skirts, trousers, jackets, shirts, coats and ties.



### THE LITTLE BLACK DRESS

Simon Henry, £14.99

Make the perfect little black dress for your me-made wardrobe with expert dressmaker Simon Henry. Choose from three classic styles – a shift, a wraparound and a strapless cocktail.



### HOME SEWN HOME

Sally Walton, £14.99

Featuring a delightful mix of retro-inspired makes and stitching tips, Sally Walton's book will bring a touch of authentic vintage flair to your home decor projects and your sewing.



### GIRL WITH A SEWING MACHINE

Jenniffer Taylor, £12.99

Learn how to upcycle and adapt items of clothing, as well as create your own unique clothes with The Great British Sewing Bee contestant Jenniffer Taylor's no-fuss guide.

LIVE everyday 8am - 12 noon • FREEVIEW CHANNEL 78 • [www.sewingquarter.com](http://www.sewingquarter.com) • [www.youtube.com/sewingquarter](http://www.youtube.com/sewingquarter)

\* Offer for new customers only. No minimum spend necessary. Standard P&P on all orders is £2.95. Offer is available online only and can be redeemed by using voucher code SS2018 at the checkout on [www.SewingQuarter.com](http://www.SewingQuarter.com). Offer expires 1st February 2018 at 23:59, or when stock runs out. Voucher code is not redeemable on TV promoted product within the 24hrs it is on air. For full terms and conditions, please visit the Sewing Quarter website.

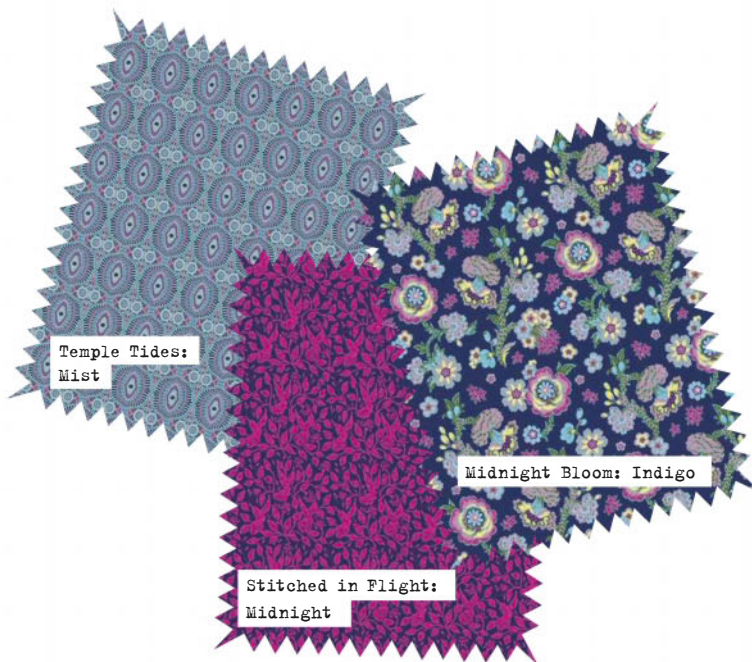

## HOME AGAIN

▼ **NO PLACE LIKE HOME** BY LEAH DUNCAN FOR CLOUD9 FABRICS  
We're off to see the wizard with Leah Duncan's latest designs inspired by her love for *Wizard of Oz*, featuring beloved characters, classic lyrics and iconic scenery in a delicate palette that has us dreaming up our own visit to Oz. [www.hantex.co.uk/cloud9](http://www.hantex.co.uk/cloud9)

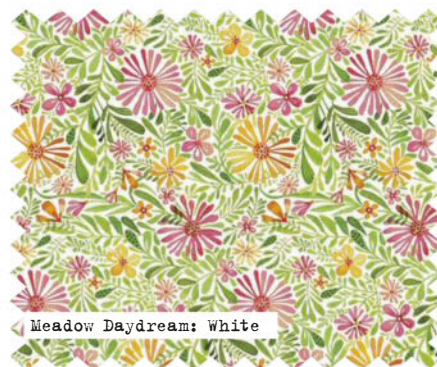
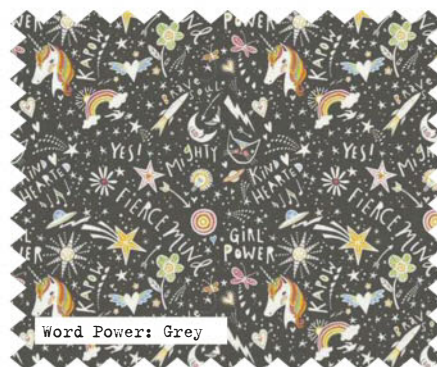

## PERFECT HARMONY

**NIGHT MUSIC** BY AMY BUTLER FOR FREESPIRIT  
According to folklore from the Gond tribe in central India, the forest is busy during the day providing shade, shelter and food for humans and animals – but at night the real spirit of the trees emerges. Amy has captured this in her mythology-inspired collection, *Night Music*; an inky navy base brings lush, jewel-toned florals and bright botanicals to life in these magical, atmospheric prints. [www.freespiritfabrics.com](http://www.freespiritfabrics.com)

## ALL THINGS NICE

**SUGAR & SPICE** BY CORI DANTINI FOR BLEND FABRICS  
Bring some girl power to your sewing projects with these fun prints by Cori Dantini. Unicorns, spaceships, hearts, cats, butterflies, motivational words and shooting stars combine in a collection that serves up sugar and spice with a side of sass. [www.blendfabrics.com](http://www.blendfabrics.com)

## RISE AND SHINE

**SUNSHINE** BY ALEXIA MARCELLE ABEGG FOR COTTON + STEEL  
Infuse your fabric stash with the warmth of a summer's day and indulge in a little nostalgia with these charming prints. Designer Alexia Abegg was inspired by fond memories of the arts and crafts she enjoyed as a child to create simple imagery that takes us back to our own childhood crafternoons (as well as providing plenty of ideas for our future crafting sessions!). The warm palette is reminiscent of the long summer afternoons Alexia spent drawing, making and paper-collaging after school, with prints including stamped florals, grinning suns, playful mice, and even friendly lions wearing the same striped tee Alexia used to wear for playtime. We've got oh-so-sweet children's makes planned for these designs – little ones will love spotting the smiling faces and familiar shapes. [www.cottonandsteelfabrics.com](http://www.cottonandsteelfabrics.com)



# WIN! A NEW SEWING BOOK

Enter for your chance to win a copy of *Stylish Home Sewing* by Torie Jayne.

When we aren't stitching the latest *Simply Sewing* patterns, there's nothing we like more than sewing some handmade loveliness for our homes. Torie Jayne's blog ([www.toriejayne.com](http://www.toriejayne.com)), is one of our go-tos for inspiration, and so is her new book *Stylish Home Sewing*, published by CICO Books, with 35 sewing projects to help you bring some of Torie's signature style into your abode, including the fab laundry set on p78! We've got 10 copies to give away. Enter now at [www.simplysewingmag.com](http://www.simplysewingmag.com)

10 NEW BOOKS TO GIVEAWAY!



## FIVE STITCHING SETS TO BE WON!

We've got bumper bundles of sewing goodies to give away, worth £74 each.

We're firm believers that there is no such thing as having too much craft stash, which is why we're so excited about the goodies we have to give away from some of our favourite sewing brands. Each of the five sets up for grabs contains a Milward scissors set, a new Gütermann Portofino fabric bundle and coordinating thread set, and a roll of the prettiest heart ribbon from Berisfords. For your chance to win enter at [www.simplysewingmag.com](http://www.simplysewingmag.com), and for stockists email [groves@stockistenquiries.co.uk](mailto:groves@stockistenquiries.co.uk), [berisfords@stockistenquiries.co.uk](mailto:berisfords@stockistenquiries.co.uk) and [gutermann@stockistenquiries.co.uk](mailto:gutermann@stockistenquiries.co.uk)

See [www.simplysewingmag.com](http://www.simplysewingmag.com) to enter today! (UK only, see competition rules on p6.)

# Simply Sewing

FRESH IDEAS WITH FABRIC



START YOUR FREE TRIAL TODAY\*!

- Download the latest issue straightaway, for free
- Your next issue is free too
- Get a further 12 issues in your first year
- All issues download automatically
- Download it once... read it offline forever



iPad is a trademark of Apple Inc., registered in the U.S. and other countries. App Store is a service mark of Apple Inc. NOOK is a registered trademark of Barnes & Noble, Inc. NOOK Tablet is a trademark of Barnes & Noble, Inc

\*Free trial not available on Zinio

SAVE TIME, MONEY AND HASSLE WITH AN ANNUAL SIMPLY SEWING SUBSCRIPTION



**+ WIN!**  
\$999 SEWING PRIZES\*

# Simply Sewing

FRESH IDEAS WITH FABRIC

PLUS SEW YOUR OWN GYM ACCESSORIES

Make me!

ISSUE THIRTY EIGHT



BALLERINA PLUSHE FOR PLAYTIME

24 PROJECTS TO MAKE  
**EASY-WEAR ALICE DRESS**  
IN SIZES 6-20

**JUST TAP  
HERE TO  
SUBSCRIBE  
TODAY**

**+ WIN!**  
\$999 SEWING PRIZES\*

# Simply Sewing

FRESH IDEAS WITH FABRIC

24 PROJECTS TO MAKE  
**EASY-WEAR ALICE DRESS**  
IN SIZES 6-20



BALLERINA PLUSHE FOR PLAYTIME

**FLATTER & FIT**  
Relaxed fabrics & styles for everyday wear

**FLATTER & FIT**  
Relaxed fabrics & styles for everyday wear

**TO SUBSCRIBE SIMPLY VISIT:  
WWW.SIMPLYSEWINGMAG.COM/DIGITAL**

\* Free trial not available on Zinio.  
The digital version of the magazine does not include the cover gift that you would find on newsstand copies.



# LET'S DO THIS!

Give your sewing skills a workout and upgrade your gym kit with coordinating floral prints.

Designer: **JESSICA ENTWISTLE** Styling: **LISA JONES** Photography: **PHILIP SOWELS**





#### PHONE ARMBAND

Keep your hands free while you're running, walking or at the gym with this phone armband – it features a layer of protective iron-on fleece and a secure flap fastening to hold your phone in place while it plays your workout playlist of choice (we favour an 80s power ballad, FYI).

#### GYM HOLDALL

New year, new gear! Much like us after an aerobics class, our gym bag is looking a little tired, so we're sewing up a durable holdall that'll work for whatever kind of fitness you're into, with fully adjustable D-ring straps for a yoga mat (or if fabric-shopping is your cardio, it would be ideal for carrying your latest finds home, too!).





### TRIMMED TOWELS

Whether you've just worked up a sweat at a class or treated yourself to an at-home pampering session, dry off with a towel trimmed in your favourite fabrics. We've mixed floral prints for a coordinated gym set (and will be making another for our bathroom, natch).

### KNOT HEADBAND

Nail the sports-luxe trend and channel *Flashdance* vibes with this simple knotted headband for a no-fuss 'do for workouts, brunch dates and sewing sessions – it's the perfect first project if you're new to sewing with jersey.



### HEADPHONE PURSE

Whether we're at the gym or doing the daily commute, headphones are an essential for keeping us entertained with podcasts, Insta stories and our favourite tunes. No matter how neatly we put them away, though, ours always end up a tangled mess, so we're raiding the scraps stash to make this handy little purse.

### DRAWSTRING WASH BAG

We love to sew versatile makes we can use everyday, and this drawstring wash bag certainly ticks that box. This practical bag has pockets for all the essentials and can be used for at-home storage, weekends away and at the gym or spa (which means more opportunities for showing off our stitching skills – hurrah!).





## GYM HOLDALL

### YOU WILL NEED

- Main fabric: 90x112cm (36x44in)
- Contrast fabric: 90x112cm (36x44in)
- Strap fabric: 70x75cm (28x30in)
- Medium-weight iron-on interfacing: 70x75cm (28x30in)
- Iron-on fleece: 100x90cm (40x36in)
- 4 D-rings: 3cm (1¼in) wide
- Zip: 71cm (28in)
- Matching sewing thread
- Erasable fabric pen
- Basic sewing kit

### FABRICS USED

The fabrics used are from Modern Retro by Makower uk. For fabric stockists visit [www.makoweruk.com](http://www.makoweruk.com)  
**Main fabric:** Flowers, Blue. Ref: 1843/B.  
**Lining fabric:** Ditzzy Flower, Ivory. Ref: 1844/Q.  
**Straps:** Linea, Cameo. Ref: 1525/B2.

### NOTES

- Use a 1cm (¾in) seam allowance.
- Download the template from [www.simplysewingmag.com/downloads](http://www.simplysewingmag.com/downloads)

### CUTTING OUT

**Step one** Download the template and cut it out.

**Step two** Press the fleece onto the wrong side (WS) of the main fabric then cut out:

**Bag front and back:** use the template to cut one each of these.

**Zip strips:** cut two 8x66cm (3¼x26in).

**Gusset strips:** cut two 14x47.5cm (5½x18¾in).

**Step three** From the lining fabric cut out:

**Front lining and back lining:** use the template to cut one each of these.

**Zip lining strips:** cut two 8x66cm (3¼x26in).

**Gusset lining strips:** cut two 14x47.5cm (5½x18¾in).

**Step four** Press the interfacing onto the WS of the strap fabric then cut out:

**Front strap:** two pieces 12x75cm (4¾x29½in).

**Back strap:** two pieces 12x72cm (4¾x28¾in).

**D-ring holder straps:** two pieces 12x24cm (4¾x9½in).

### MAKING THE STRAPS

**Step one** Place the two front straps right sides (RS) facing and stitch together across the short ends. Repeat for the two back strap pieces.

**Step two** Fold the back strap in half lengthways with WS together. Open it out and then fold the long edges to the centre and press. Fold in half again and press to create a 3cm (1¼in) wide

strip. Topstitch down both long edges.

**Step three** Repeat this with the front strap but turn both short edges under by 1cm (¾in) to the WS first before folding the long edges and topstitching down them.

**Step four** Fold and press the D-ring holder straps in the same way but only fold one short end under. Topstitch around all the edges.

**Step five** Take a pair of D-rings and thread them onto one end of the front strap. Fold the end under by 2cm (¾in) and stitch it in place.

**Step six** Repeat with the other pair of D-rings at the other end of the front strap.

**Step seven** Fold the two front straps in half widthways and mark the centre points.

**Step eight** Mark 36.5cm (14in) out from the centre point either side. This is where the straps are sewn onto the bag front and back. 01

### MAKING THE BAG GUSSET

**Step one** Place one of the main fabric zip strips RS together with the zip centrally placed down the length. The long raw edge of the fabric should match up with the edge of the zip tape.

**Step two** Stitch together using a zip foot, then turn RS out and topstitch down the length of the fabric close to the zip tape.

**Step three** Repeat this with the main fabric zip strip on the other side of the zip, making sure



**BUY THIS KIT!**

**Sewing  
QUARTER**

See this demonstrated  
live on air on  
20th January 2018 \*

**Live on  
Freeview 78**

\* Visit page 15 for special offers and T&Cs

the strip short ends line up. You will now have a zip sandwich that is the same width as the bag gusset strips.

**Step four** Place the zip slider in the centre then trim off the ends of the zip so they are level with the short edges of the fabric then backstitch over the ends to secure the zip teeth.

**Step five** Mark the centre point of the long edges of both pieces of fabric.

**Step six** Pin one of the bag gusset strips RS together with one of the short edges of the zip sandwich. Sew together, press the seam open, then topstitch in place.

**Step seven** Repeat this on the other short edge of the zip sandwich with the other gusset. **02**

### SEWING THE STRAPS IN PLACE

**Step one** For both the main fabric front and back pieces you need to transfer the following marks from the template: zip placement points, centre points for the top and bottom and the strap line up marks for both top and bottom.

**Step two** On the bag front only, mark 3cm (1¼in) wide horizontal lines positioned 3cm (1¼in) down from the top strap marks which are along the top edge. Then mark 11cm (4¾in) down from that to create a 3x11cm (1¼x4¾in) box. This is where your front strap will be sewn on.

**Step three** Take the front strap with D-rings

attached, line up the marked lines on the strap with the top 3cm (1¼in) marked lines on the bag and pin into place. If you wish, draw the 11cm (4¾in) box onto the strap to make it easier to follow the sewing lines.

**Step four** Sew the strap onto the bag front along the 11cm (4¾in) box only.

**Step five** Stitch the two D-ring holder straps to the bottom of the bag, lining them up with the bottom strap marks. **03**

**Step six** For the bag back, draw 3cm (1¼in) wide horizontal lines positioned 3cm (1¼in) down from the top strap marks along the top edge as before, but this time draw vertical lines down from these to the bottom strap marks.

**Step seven** Lining up the bag strap marks with the 3cm (1¼in) horizontal marks on the bag back, pin then sew the strap to the bag. **04**

### ATTACHING THE GUSSETS

**Step one** Sew the bag gusset strips RS together along the short ends to make a wide loop.

**Step two** With RS facing, pin the bag gusset strip on top of the bag front, by starting at the top middle marked points. Pin the strip all the way around to the bottom, making sure the zip ends line up with the zip marked points on the bag front. Snip the strip at the curved edges.

**Step three** Sew the strip to the bag front. **05**

**Step four** Open up the zip then repeat to sew the bag back to other side of the gusset strip. **06**

### MAKING THE LINING

**Step one** Fold one long edge of one lining zip strip over by 1cm (¾in) to the WS. Press then topstitch this turned-over edge in place.

**Step two** Repeat with the other lining zip strip.

**Step three** Pin the two lining strips RS facing with one of the lining gusset short sides, so that the topstitched edges are in the middle and the outer edges line up. Sew in place.

**Step four** Press open then topstitch in place.

**Step five** Repeat with the other lining gusset.

**Step six** Attach the gusset lining to either side of the lining front and back as before. **07**

### ASSEMBLING THE BAG

**Step one** Put the bag outer inside the lining with WS facing, making sure the zip is open.

**Step two** Pin and then slip stitch the lining to the bag along the zip edges making sure you don't sew through the zip teeth. **08**

**Step three** Turn RS out through the zip.

**Step four** Thread the ends of the front strap through the D-rings to attach your yoga mat.



## HEADPHONE PURSE

### YOU WILL NEED

- Main fabric: 15x21cm (6x8¼in)
- Contrast fabric: 15x15cm (6x6in)
- Zip: 15cm (6in)
- Swivel clip
- Split ring
- Matching sewing thread
- Erasable fabric pen
- Basic sewing kit

### FABRICS USED

The fabrics used are from Modern Retro by Makower uk. For fabric stockists visit [www.makoweruk.com](http://www.makoweruk.com)

**Main fabric:** Ditzzy Flower, Ivory.

Ref: 1844/Q.

**Lining fabric:** Leaf, Blue. Ref: 1846/B5.

### NOTES

- Use a 1cm (¾in) seam allowance.

### CUTTING OUT

**Step one** From the main fabric cut:

**Outer:** two pieces 7.5x15cm (3x6in).

**Tab:** 6x6cm (2¾x2¾in).

**Step two** From the contrast fabric cut:

**Lining:** two pieces 7.5x15cm (3x6in).

### INSERTING THE ZIP

**Step one** Place one each of the lining and outer pieces right sides (RS) together with the zip RS up centrally between them. Match the zip tape and raw fabric edges. Pin all layers together. <sup>01</sup>

**Step two** Sew together using a zip foot.

**Step three** Flip the fabric pieces over so they are wrong sides (WS) facing. Press and then topstitch along the seam.

**Step four** Repeat this for the other outer and lining pieces on the other side of the zip tape.

### JOINING THE OUTERS AND LININGS

**Step one** Open the zip so the slider is in the centre. Put the two lining pieces RS together matching long raw edges. Sew together along this edge leaving a 5cm (2in) turning gap.

**Step two** Repeat this with the two outer fabric pieces, but don't leave a turning gap. <sup>02</sup>

### STITCHING THE END SEAMS

**Step one** Fold the tab strip in half RS together.

**Step two** Open out, fold the two long edges into the centre. Fold in half and press again then topstitch down the long edges to create a tab strip 1.5cm (½in) wide.

**Step three** Lay the purse flat, WS out with the zip running down the centre of the top and the seam directly beneath it and press.

**Step four** Fold the tab in half to create a loop and slip it inside the outer on the side where the zip closes, matching raw edges. <sup>03</sup>

**Step five** Sew together along both raw edges then trim off the excess zip ends.

### BOXING THE CORNERS

**Step one** Turn the purse RS out through the gap in the lining then slip stitch the gap closed.

**Step two** With the lining RS out push out the corners with the lining and outer together.

**Step three** Take one corner and pinch it into a triangle so that the sewn lining seam is in the middle of the triangle and the outer fabric piece corner is sandwiched inside.

**Step four** Draw a line across 1.5cm (½in) down from the point and sew along it. Leaving the corners untrimmed gives the purse structure.

**Step five** Repeat this for the other corners. <sup>04</sup>

**Step six** Turn RS out then thread the split ring through the tab loop then the toggle clasp onto the split ring to finish.



## HEADBAND

### YOU WILL NEED

- Knit fabric: 40x60cm (16x24in)
- Matching sewing thread
- Erasable fabric pen
- Basic sewing kit

### FABRICS USED

Heartland Liten Ditsy Whisper Knit by Art Gallery Fabrics. Ref: AGFHRT95305K. For stockists visit [www.hantex.co.uk/agf](http://www.hantex.co.uk/agf).

### NOTES

- Use a 1cm (3/8in) seam allowance.
- Use a ballpoint needle in your sewing machine for knit fabrics.

### CUTTING OUT

**Step one** Cut the knit fabric into two strips each measuring 20x60cm (8x24in).

### MAKING THE TUBES

**Step one** Fold one strip in half lengthways with right sides (RS) facing.

**Step two** Pin and sew the strip together down the length.

**Step three** Repeat this with the other strip to create two fabric tubes.

**Step four** Press the seams open then turn the tubes RS out.

**Step five** Press again, making sure the seams run down the centre of one side.

### ASSEMBLING THE HEADBAND

**Step one** Lay one tube down horizontally with the seam facing up. Lay the other tube on top vertically with the seam facing down so that both tube seams are facing to create a cross shape as shown. **01**

**Step two** Take the right end of the horizontal tube and fold it over to the left side so that the two raw edges meet. **02**

**Step three** Fold the vertical strip over with seams facing each other so that both of the raw ends meet. The photo shows the finished folded strips to help with this. **03**

### FINISHING OFF

**Step one** Pin all four raw ends together to create a fat fabric sandwich.

**Step two** Sew the four ends together.

**Step three** Flip the sewn seam to the inside of the headband so that it's hidden from view. **04**

**Step four** Slip the headband over your head and pull it up onto your hair so the seam is at the nape of your neck and the loops are on top.

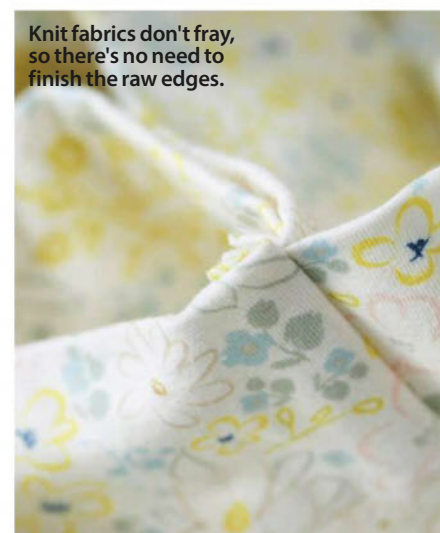



## TOWELS

### YOU WILL NEED

- Main fabric: see instructions for details
- Towel
- Matching thread
- Erasable pen
- Basic sewing kit

### FABRICS USED

The fabrics used are from Modern Retro by Makower uk. For fabric stockists visit [www.makoweruk.com](http://www.makoweruk.com)  
 Flowers, Blue. Ref: 1843/B.  
 Ditzzy Flower, Ivory. Ref: 1844/Q.

### NOTES

- Use a 1cm (3/8in) seam allowance.
- Use a longer machine stitch then normal for topstitching to sew neatly through all the layers.

### CUTTING OUT

**Step one** Measure the width and the length of your towel.

**Step two** Cut two long edge strips 8cm (3/8in) wide and the length of your towel.

**Step three** Cut two short edge strips 8cm (3/8in) wide and the width of your towel plus 4cm (1 1/2in) for turning.

**Step four** Cut one hanging loop strip 8cm (3/8in) wide x 22cm (8 3/4in).

### MAKING THE HANGING LOOP

**Step one** Fold the hanging loop strip in half lengthways with right sides (RS) facing.

**Step two** Pin and then sew the strip together down the length.

**Step three** Turn RS out and press with the seam along one edge.

**Step four** Topstitch down both long edges.

### BINDING THE LONG EDGES

**Step one** Fold one long edge strip in half lengthways with wrong sides (WS) together and press to make a crease on the fold.

**Step two** Open out then press the two long raw edges over by 1cm (3/8in) to the WS and press.

**Step three** Fold back in half again along the pressed crease and you now have a wide bias strip for binding the towel.

**Step four** Repeat to fold and press the other long edge strip.

**Step five** Place one long edge of the towel inside one of the folded long edge strips so that the strip encases the towel edge. Topstitch in place close to the edge. **01**

**Step six** Repeat this on the other long edge of the towel with the other long edge strip, but this time tuck the raw edges of the hanging loop 1cm (3/8in) inside the border strip in the centre of the towel edge on the reverse side and pin into place.

**Step seven** Fold the loop up and tack it to the strip to hold. **02**

**Step eight** Topstitch the long strip to the towel in the same way as before. **03**

### BINDING THE SHORT EDGES

**Step one** Take one of the short edge strips and fold and press it in the same way as for the long edge strips but this time press the short edges under by 2cm (3/4in) to the WS before pinning it to one short edge of the towel.

**Step two** Make sure the towel is tucked inside one of the pressed-under short ends for each edge before topstitching into place as before, to ensure a neat finish. **04**

**Step three** Repeat this at the other short end of the towel using the other short edge strip.



## ARMBAND

### YOU WILL NEED

- Main fabric: 18x22cm (8x9in)
- Contrast fabric: 18x55cm (8x22in)
- Iron-on fleece: 18x30cm (8x12in)
- Elastic: 3.5cm (1½in) wide x 20cm (8in)
- Matching sewing thread
- Erasable fabric pen
- Basic sewing kit

### FABRICS USED

The fabrics used are from Modern Retro by Makower uk. For fabric stockists visit [www.makoweruk.com](http://www.makoweruk.com)

**Main fabric:** Flowers, Blue. Ref: 1843/B.

**Contrast fabric:** Linea, Cameo. Ref: 1525/B2.

### NOTES

- Use a 1cm (¾in) seam allowance.

### CUTTING OUT

**Step one** From the main fabric cut two pieces 11x18cm (4¾x7½in) for the outer.

**Step two** From the contrast fabric cut:

**Lining:** two pieces 11x18cm (4¾x7½in).

**Flap:** two pieces 10x11cm (4x4¾in).

**Band:** 8x11cm (3¼x4¾in).

**Step three** From the iron-on fleece cut:

**Main body:** two pieces 11x18cm (4¾x7½in).

**Flap:** one piece 10x11cm (4x4¾in).

### PREPARING THE OUTERS AND LINING

**Step one** Press the fleece onto the wrong side (WS) of the main fabric outer pieces and one of the contrast fabric flap pieces.

**Step two** Pin the padded flap fabric piece right sides (RS) facing with the other flap piece.

**Step three** Mark then cut a slight curve on the two corners of one of the short sides.

**Step four** Sew together around three sides, leaving the straight short side unstitched.

**Step five** Clip the corners, turn RS out and topstitch along the edges.

**Step six** Pin the lining pieces RS facing then sew together down the two long edges and one short edge, leaving a turning gap in the centre.

### MAKING THE BAND

**Step one** Fold the band fabric in half lengthways

RS facing and sew together down the length.

**Step two** Turn RS out and press with the seam running down the centre of the back.

**Step three** Topstitch down both long edges. <sup>01</sup>

### ATTACHING THE BAND, ELASTIC AND FLAP

**Step one** Place the band RS up across the top of the RS of one of the padded main fabric pieces 4cm (1½in) down from the top.

**Step two** Stitch in place down both sides within the seam allowance. This is the armband front.

**Step three** Pin the elastic across the other padded main fabric piece 7cm (2¾in) down from the top short edge.

**Step four** Stitch in place down both sides within the seam allowance. This is the armband back.

**Step five** Stitch the flap RS together centrally across the top of the armband back. <sup>02</sup>

### ASSEMBLING ALL THE PIECES

**Step one** Pin the front and back RS facing then sew together down the long sides and across the bottom short side. Turn RS out and press. <sup>03</sup>

**Step two** Place the armband out inside the lining so they are RS facing. Pin then sew together around the top edge. <sup>04</sup>

**Step three** Turn RS out through the turning gap and press then slip stitch the turning gap closed and tuck the lining back inside to finish.

## WASH BAG

### YOU WILL NEED

- Main fabric: 25x85cm (10x36in)
- Contrast fabric: 45x85cm (18x36in)
- Iron-on fleece: 25x85cm (10x36in)
- Cord: 1m (1yd)
- Spring toggle
- Matching sewing thread
- Erasable fabric pen
- Basic sewing kit

### FABRICS USED

The fabrics used are from Modern Retro by Makower uk. For fabric stockists visit [www.makoweruk.com](http://www.makoweruk.com)

**Main fabric:** Leaf, Green. Ref: 1846/G.

**Contrast fabric:** Ditzzy Flower, Ivory. Ref: 1844/Q.

### NOTES

- Use a 1cm (3/8in) seam allowance.
- Download the template from [www.simplysewingmag.com/downloads](http://www.simplysewingmag.com/downloads)

### CUTTING OUT

**Step one** Download the template and cut it out.

**Step two** Press the fleece onto the wrong side (WS) of the main fabric then cut out the following pieces:

**Outer body:** 25x58.5cm (10x23in).

**Outer base:** use your template to cut a circle.

**Step three** From the contrast fabric cut out the following pieces:

**Lining body:** 25x58.5cm (10x23in).

**Pockets:** 13x58.5cm (5 1/4x23in).

**Cord strip:** 7x58.5cm (2 3/4x23in).

**Lining base:** use your template to cut a circle.

### MAKING THE LINING

**Step one** Fold one of the long edges of the pocket piece over by 1cm (3/8in) to the WS and press then turn it over by 1cm (3/8in) again and press. Stitch this double hem into place.

**Step two** Pin the pocket piece right side (RS) up to the RS of the lining body piece so the bottom edges match up. Stitch into place along the bottom edge within the seam allowance.

**Step three** Draw vertical lines down the pocket piece varying distances apart. We made ours every 11-15cm (4 3/8-6in).

**Step four** Sew along these pocket lines to create smaller pockets, making sure you backstitch at the top of the seam where the pocket edge meets the lining to give the pockets strength.

**Step five** Fold the two short edges of the cord strip over by 1cm (3/8in) to the WS.

**Step six** Fold the edges over by 1cm (3/8in) again and press.

**Step seven** Stitch this double hem into place.

**Step eight** Pin and then sew the cord strip RS together centrally across the top of the pocket lining, matching raw edges. **01**

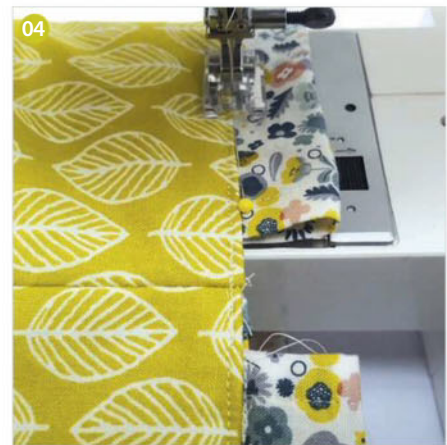

### SEWING THE LINING TO THE OUTER

**Step one** Press the cord strip seam over towards the bag lining.

**Step two** Pin the outer body RS together to the raw edge of the cord strip, making sure the short edges of the lining and outer line up.

**Step three** Sew together then press the seam towards the outer.

**Step four** Topstitch carefully on the top of the sewn seams.

**Step five** Fold the sewn bag in half RS facing then pin together so the short edges meet.

**Step six** Sew the bag outer together, then sew the bag lining together but leave a turning gap in the bag lining as shown. **02**

### ATTACHING THE BASES

**Step one** Mark the quarter points of the outer base by folding it in half, then half again.

**Step two** Mark the quarter points on the raw bottom edge of the sewn bag outer.

**Step three** Snip the fabric edge all the way around, making the cuts just 5mm (1/4in) so they lie within the stitched seam later. This makes joining the circular base to the outer easier.

**Step four** Pin the base to the bag end, matching the quarter points and using lot of pins. **03**

**Step five** Sew the base into place then repeat this with the lining base and lining body.

**Step six** Turn RS out through the turning gap and press, then slip stitch the gap closed.

### FINISHING OFF

**Step one** Line up the bag lining and outer edges then stitch on top of the seam through all layers all the way around to create the channel for threading the cord through. **04**

**Step two** Topstitch along the open edge between the channel gap to finish off your bag.

**Step three** Thread the cord through the channel and through the spring toggle, knotting the cord ends together to finish.

**For extra durability, add a waterproof coating to your chosen fabric or make your wash bag in oilcloth.**



# PINUP

Sew up a durable duffle bag for New Year adventures.



Whether your idea of a workout session is an hour at the gym or an afternoon at the fabric store (we certainly know which one we'd choose!) kick-start your 2018 sewing projects with this issue's Gym Bag pattern. Ours is sewn up in floral canvas from Art Gallery Fabrics with faux leather details and webbing straps for durability. This versatile, roomy duffle style is like two bags in one – it's the perfect size for gym essentials, and doubles up as an overnight bag for your travels, too. Here's to a new year, new skills and new adventures!

PSST!

Turn overleaf for fabric and styling inspiration, plus an exclusive 20% discount code to use at [www.girlcharlee.co.uk](http://www.girlcharlee.co.uk)





# THE ALICE DRESS

Give your skills a boost and learn to sew with knits with **The Alice Dress** in UK sizes 6-20, a faux-wrap jersey dress with two sleeve and skirt lengths.

# THE ALICE DRESS

With a new year of crafting ahead, now is the time to challenge ourselves with new skills and projects – and we're ticking 'sew with knits like a pro' off our list first thanks to The Alice Dress in UK sizes 6-20 (US 4-18/EUR 34-48).

This simple-sew ballet-inspired frock features a feminine faux-wrap bodice, gathered skirt and two sleeve and skirt lengths. Be sure to share yours with us tagged #simplysewingmag!

## YOU WILL NEED

### ■ Fabric:

Dress A: 115cm (45in) width fabric x 2.6m (3yds);  
140cm (55in) width fabric x 1.9m (2¼yds) for all sizes

Dress B: 115cm (45in) width fabric x 3m (3¼yds);  
140cm (55in) width fabric x 2.2m (2½yds) for all sizes

- Clear elastic: 1cm (¾in) width x 110cm (43in)
- Ballpoint and twin sewing machine needles
- Matching thread

## FABRIC SUGGESTIONS

- Light to medium weight knit fabrics with at least 30% stretch.

## GETTING STARTED

First, pre-wash and dry your chosen fabric to allow for any shrinkage. Unfold the pattern sheets and find the line style for your size using the key provided. Follow these lines to cut your pattern pieces out – it can be helpful to mark them using a highlighter before cutting. Read through the instructions before you start, get your sewing kit ready, press the fabric to ensure accurate cutting out, and you're ready to start on the fun part – sewing your Alice Dress!

## CHOOSING YOUR JERSEY

Alice is designed for light to medium weight knits, which gives you almost endless options to play with! Give these key jersey types a try.

- Cotton jersey: One of the most popular jersey fabrics thanks to its soft, fluid drape, available in a variety of weights to suit your project.
- Ponte de roma: A thicker, more stable knit that's ideal for jersey-sewing newbies.
- Cotton Lycra: A blend of cotton and Spandex or Lycra with excellent stretch and recovery.



### WRAP STYLE

Features a faux-wrap bodice for stylish layering.

### GATHERED SKIRT

The gathered skirt gives an easy-wear, flattering fit.

### TWO LENGTHS

Choose from two sleeve and skirt lengths.

## GET 20% OFF AT GIRL CHARLEE!

Get 20% off at Girl Charlee using the code GIRL38 at [www.girlcharlee.co.uk](http://www.girlcharlee.co.uk). Offer valid until 25th January 2018.

Code cannot be used with any other codes and does not apply to sale items, bargain lots, patterns and gift cards.





Pick a multi-hued design for lots of layering options, [www.girlcharlee.co.uk](http://www.girlcharlee.co.uk)



Mint Cotton Spandex, [www.girlcharlee.co.uk](http://www.girlcharlee.co.uk)



Grey Dot Cotton Spandex, [www.girlcharlee.co.uk](http://www.girlcharlee.co.uk)



Cotton Spandex Knit, [www.girlcharlee.co.uk](http://www.girlcharlee.co.uk)

**FABRIC INSPIRATION**

**WRAP STAR**

Alice's feminine faux-wrap detail is the perfect excuse to go girly with a palette of pastel pinks, blues and greens.



Pink Cotton Spandex, [www.girlcharlee.co.uk](http://www.girlcharlee.co.uk)



Flyaway Petalums Sky, [www.artgalleryfabrics.com](http://www.artgalleryfabrics.com)



Plumage Apricot, [www.artgalleryfabrics.com](http://www.artgalleryfabrics.com)



We've got a spring wedding frock in mind for this pretty abstract floral, [www.artgalleryfabrics.com](http://www.artgalleryfabrics.com)

WEAR IT WITH

**BACK TO BASICS**

Let your dress do the talking with chic neutral accessories.

*Cheat your way to an I-woke-up-like-this glow with a peachy lip crayon. £9.50, [www.marksandspencer.com](http://www.marksandspencer.com)*



Do a barely-there mani for low-key luxe. £3.99, [www.newlook.co.uk](http://www.newlook.co.uk)



Go sculptural with minimal disc drop earrings, £2, [www.primark.com](http://www.primark.com)

Don delicate fronds for a subtle way to wear the botanical trend, £7, [www.apricotonline.co.uk](http://www.apricotonline.co.uk)



Mix and match chic tonal shades for a far-from-boring neutral look. £8, [www.primark.com](http://www.primark.com)



*Elegant heels we can actually walk (and dance) in? Win! £120, [www.jonesbootmaker.com](http://www.jonesbootmaker.com)*





## JEAN GENIUS

**Portia Lawrie** revamps an old oversized pair of jeans into a classic denim pencil skirt with a bleached twist.

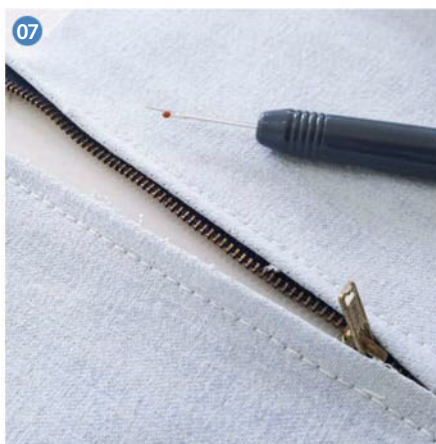
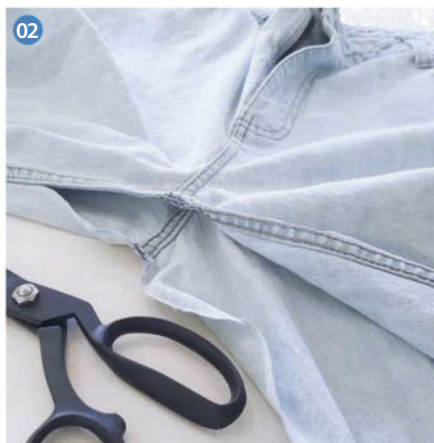

## YOU WILL NEED

- 1 pair of baggy oversized jeans: pure cotton with no lycra
- Erasable fabric marker
- Matching thread
- Basic sewing kit
- Household bleach (optional)

## NOTE

- Use a 1cm (3/8in) seam allowance.

## BLEACHING THE JEANS

**Step one** Wet the jeans thoroughly and then submerge them completely in a solution of one part bleach to one part water. Leave to soak, rotating the jeans and checking on them every 15 minutes until you are happy with the shade. **Step two** Remove and immediately wash them on a 40° cycle in your machine with detergent. **Step three** Hang to dry naturally away from direct heat or sunlight. **01**

## CUTTING THE PIECES

**Step one** Cut straight along the inner leg seam, keeping close to the seam and starting from one ankle and cutting all the way along to the other ankle. **02**

**Step two** Open the jeans out flat right sides (RS) out with the side seams on top of each other and then cut straight across the top of the legs, separating the top section from the legs just below the crotch as shown. **03**

**Step three** Cut the hem off the jeans.

**Step four** Cut each leg section into two pieces. You will have two front legs and two back legs.

**Step five** Keep the two front legs together for the skirt front, and the two back legs together for the skirt back. **04**

## MAKING THE SKIRT FRONT AND BACK

**Step one** Square each leg piece off – you can use the warp thread in the jeans as your vertical

reference point. Line up your square ruler as close as you can get to the edge then mark and trim away the excess. **05**

**Step two** Repeat this on both sides of all four of the leg pieces.

**Step three** Sew the front legs RS together along the straight edge. This is your centre front (CF) seam. Press the seam open. **06**

**Step four** Sew the back legs RS together along the straight edge for the centre back (CB) seam but use a long machine stitch for the first 18cm (7in) and the bottom 18cm (7in). Work a normal stitch length in between, backstitching either end of it to secure the stitching. These top and bottom long-stitched sections are temporary stitching which will be removed later. Press the seam open.

## INSERTING THE ZIP

**Step one** Unpick the zip from your jeans. Place the back skirt section RS down and place the zip RS down, centred on top of the temporary stitching. Tack it into place so the teeth are centred over the seam.

**Step two** Topstitch the zip into place from the RS then remove the tacking stitches and unpick the temporary stitching. **07**

## FITTING THE SKIRT

**Step one** You now have a front skirt piece with a seam down the centre, and a slightly larger

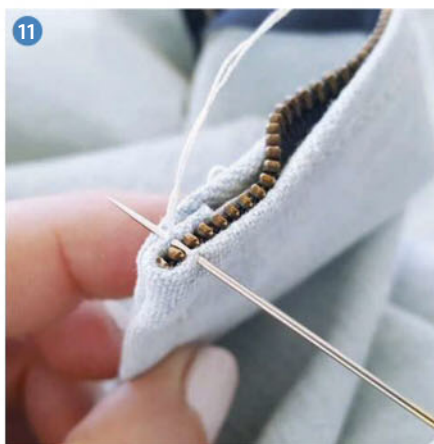
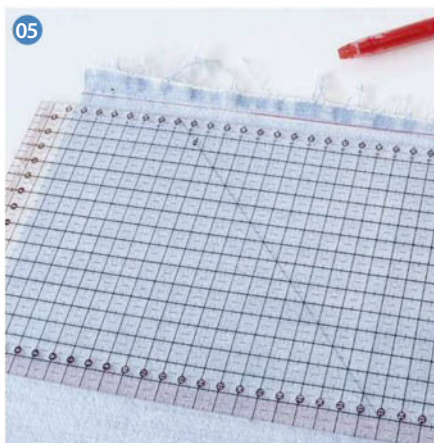

back skirt piece with a CB seam and a zip. <sup>08</sup>

**Step two** Using the longest stitch on your machine, sew the side seams RS together.

**Step three** Put the skirt on inside out and pin evenly at the side seams until the skirt fits you around the hips.

**Step four** Pin darts on the front and back until the skirt fits you in the waist.

**Step five** Unzip the skirt, and make sure you can get the skirt on and off with the zip undone.

Adjust the pins if needs be.

### STITCHING THE SIDE SEAMS

**Step one** Once you are happy with the fit, mark the position of the pins on one side only of the front and back piece. Remove the pins and even out your new seamline as shown, using an erasable fabric marker.

**Step two** Add a 1cm ( $\frac{3}{8}$ in) seam allowance, then fold each skirt piece in half lengthwise along the CF/CB seam and aligning raw edges. Use tracing paper to trace the shape of the top sections of the front and back piece and put this to one side to use for the facings.

**Step three** Cut and then sew your newly marked and shaped side seams. <sup>09</sup>

### ADDING THE FACING

**Step one** Use the tracing you made to create a facing for the waistband 12cm (5in) wide. Pin this to the top section of the jeans that you cut

off earlier.

**Step two** Join the front and back pieces RS together at the side seams. Leave the back section open at the CB with a 1cm ( $\frac{3}{8}$ in) seam allowance pressed under to the wrong side (WS) to accommodate the zip opening.

**Step three** With the zip open, stitch the facing RS together to the top of the skirt.

**Step four** Press the facing away from the skirt, understitch then trim away any excess zip. <sup>10</sup>

**Step five** Turn the facing to the inside of the skirt and press.

**Step six** Slip stitch the facing into place on the inside along the zip tape and holding it away from the teeth.

**Step seven** Where you cut away the excess zip, there is now no zip stop, so work a few stitches right at the top of the zip opening on both sides as shown to act as a new zip stop. <sup>11</sup>

### FINISHING THE SKIRT

**Step one** Unpick the bottom temporary stitching in the back of the skirt you worked earlier to open the back split.

**Step two** Topstitch around the opening to hold the split into place. <sup>12</sup>

**Step three** You can now hem the skirt if you like, but we instead simply ran a line of stitching  $\frac{1}{4}$ in (5mm) up from the raw edge. When the skirt is washed, the hem will fray up nicely.



### MORE IDEAS TO TRY

- 1 Skip the bleach and go for a straight plain denim refashion.
- 2 Re-use the waistband from the jeans instead of a waistband facing.
- 3 Re use the back pockets from the jeans as patch pockets on your skirt.
- 4 Use contrast topstitching on the centre front and back seams for extra detail.

# MY SEWING WORLD

by By Hand London

Luxe separates, relaxed silhouettes and pretty lingerie: By Hand London plan their 2018 me-made wardrobes.

We ended 2017 with the long-awaited release of our Rumana Coat pattern, so it's safe to say we were looking forward to taking a load off over the festive period. Next year will see us return to what we do best at By Hand London: party dresses and fun on the blog! We've just finalised the design for our spring pattern and a few other exciting things that we're keeping under wraps for now. The break has also given us a chance to think about our sewing goals for the upcoming year – and we're hoping that sharing our plans with you will help us keep to them!

## CHARLOTTE

My New Year's sewing resolution is to dress like a grown woman – like I've got it all vaguely-at-least-kinda-a-little-bit together. Three years into my 30s, pensioned up, mortgaged up, one baby and a husband down, I think it might be time to retire the slobby downtime uniform.

I'm an extreme dresser: a handmade or vintage party dress with red lipstick, big earrings and heels if I'm going out, or an old tee and leggings if I'm doing just about anything else. My body shape has changed a lot and I just cannot make that look work anymore – it's time for a change!

I have one caveat to my 'dressing like a lady' master plan; yes, I am after clothes that flatter, but they must be comfortable, too. There is also the tiny matter of time constraint, which brings me to part B of my 2018 sewing resolution: make smarter. Having a baby and being back at my 'real' job (advertising) means time is limited, so I've got to make the items work harder than ever before.

## IN A NUTSHELL:

- Versatile items I can wear for more than one type of occasion.
- Relaxed silhouettes (ideally no waistline, elasticated or tie-waist).
- Separate pieces to mix and match.
- Fastening-free wherever possible.
- Drapery or stretch fabrics.

I'm loving floaty frocks like my BHL Alix Dress, so drapery prints are on my fabric-shopping wish list for the New Year.



See our finished makes and new pattern releases at [www.byhandlondon.com](http://www.byhandlondon.com)



"I am after clothes that flatter, but they must be comfortable"

My Closet Case Files Charlie Caftan was a summer fave, so I've got similar projects planned for 2018.



A busy lifestyle calls for easy-wear garments with no fiddly fastenings.



*My Holly jumpsuit hack; the perfect day-to-night trousers!*

**"For 2018, my main goal is to flesh out the missing parts of my wardrobe."**

**ELISALEX**

Looking at the bulk of my wardrobes (yep, that's wardrobes plural), I have an abundance of summer party dresses (which is great), a bunch of scuzzy RTW jersey tops (not so great) and a few pairs of threadbare jeans, most of them held together with patches and some hand embroidery. For 2018, my main goal is to flesh out the missing parts of my wardrobe – basically everything that lies between the realms of red-carpet gowns and PJs – with elegant, comfortable, multi-purpose, multi-season garments I will want to wear day and night, whether out dancing or at home in the studio.

The plan is to make luxe separates and floaty dresses that drape and skim my body, thus looking fabulous whilst feeling free and relaxed. I'm going to try a temporary ban on sewing dresses with very fitted bodices (this is going to be so hard for me!). I'm also going to really try getting hooked on sewing lingerie, something I've been resisting for a while. Now that there are so many great bra patterns and gorgeous lingerie fabrics, there's no excuse!

**THE PLAN:**

- Dedicate some time to experimenting with lingerie patterns and find my tried-and-tested bras and undies.
- Sew more day-appropriate dresses that are comfortable and can be dressed up or down.
- Sew more grown-up separates – drapery shirts, silk jersey tops, wrap skirts and smart baggy trousers. Think mannish 40s styles and wide-legged wonders.
- No more summer sundresses (for now at least).



**I'm filling the wardrobe gaps with mix-and match makes like my Jennifer Lauren Handmade Gable Top and wrap circle skirt.**



*I'm on a self-imposed summer frock sewing ban...for now!*

**Keeping us inspired...**

*There's very little that inspires us as much as seeing your BHL makes- it's basically why we do what we do! It never fails to amaze us how tweaks, hacks (check out Elisalex's circle-skirt Orsola on the left) and unusual fabric choices can transform our original vision. Seeing our customers reimagine and interpret our designs keeps us coming back to our older patterns again and again with fresh eyes.*

**We could scroll through your makes for hours! Tag your snaps #byhandlondon**





# JANUARY SALE



Try something new for 2018

Subscriptions from just £1. With over 30 magazines to choose from, why not try something new this year



5 ISSUES FOR £5



5 ISSUES FOR £5



5 ISSUES FOR £5



5 ISSUES FOR £5



5 ISSUES FOR £5



5 ISSUES FOR £5



5 ISSUES FOR £5



5 ISSUES FOR £5



5 ISSUES FOR £5



12 ISSUES FOR £1



5 ISSUES FOR £5



5 ISSUES FOR £5

## GREAT REASONS TO SUBSCRIBE:

- Subscriptions starting from **just £1\***
- Continue to make **great savings** after your trial period
- Enjoy easy and convenient **delivery direct to your door**
- **Never miss an issue** of your favourite magazine

## 2 EASY WAYS TO ORDER



Visit [buysubscriptions.com/januarysale](http://buysubscriptions.com/januarysale) and enter promotional code **JS18SP**



Call **0330 053 8660\*** quote code **JS18SP**

See more great magazines online...

\*This offer closes on 12th February 2018 and is valid for UK delivery addresses and by direct debit only. The discounts shown are savings calculated as a percentage of the full shop price, excluding Radio Times and Match of the Day which are calculated as a percentage of the basic annual rate. For overseas rates visit [www.buysubscriptions.com](http://www.buysubscriptions.com). Should the magazine ordered change in frequency; we will honour the number of issues and not the term of the subscription. You are free to cancel your subscription at any time – if you cancel within 2 weeks of receiving your penultimate issue you will pay no more than the trial rate, this is with the exception of Radio Times and Match of the Day, which you will need to cancel 3 weeks before the trial is due to end. Radio Times and Match of the Day are published weekly. The Basic Annual UK Subscription rate of Radio Times is £144.78. This price is for one year and includes the Christmas double issue and a contribution towards postage. The Basic Annual rate for Match of the Day is £117 for one year. We reserve the right to limit the number of consecutive short term trial subscriptions a customer signs up for if their subscription is repeatedly cancelled during the trial. \*Calls from landlines will cost up to 9p per minute. Call charges from mobile phones will cost between 3p and 55p per minute but are included in free call packages. Lines open Mon to Fri 8am – 8pm and Sat 9am – 1pm.

# MATERIAL GIRL

Tactile cork, colour-pop Liberty and gold hardware give **Louise Orth's** simple clutch bag a luxe look.



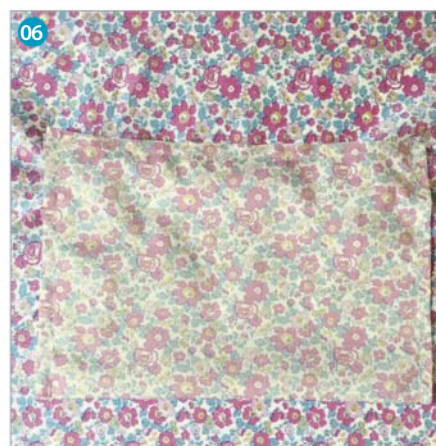
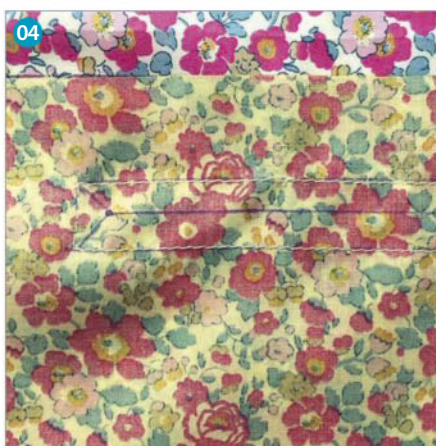
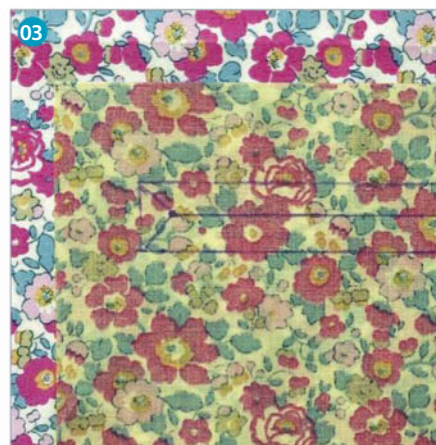
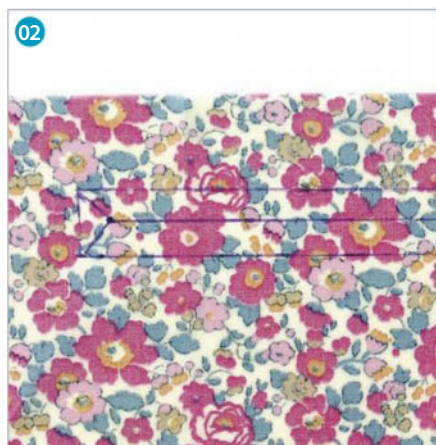

## YOU WILL NEED

- Cork fabric: one fat quarter
- Lining fabric: one fat quarter
- Zip: 15cm (6in)
- Bag trim: pointed trim, 19cm (7½in) width x 63mm (2½in) depth
- Magnetic clasp
- Erasable marker
- Basic sewing kit

## MATERIALS USED

- **Cork fabric:** Portuguese Cork Fabric, Natural. From [www.frameyourbag.etsy.com](http://www.frameyourbag.etsy.com)
- **Bag trim:** Emmaline Bags Metal Edge Trim, Style A in Gold Finish. From [www.sewhot.co.uk](http://www.sewhot.co.uk)
- **Liberty fabric:** Tana Lawn Exclusive Collection 360 from [www.alicecaroline.co.uk](http://www.alicecaroline.co.uk)

## NOTES

- Use a 1cm (¾in) seam allowance.
- Download the template from [www.simplysewingmag.com/downloads](http://www.simplysewingmag.com/downloads)

## CUTTING OUT

- Step one** Download the template and cut it out.
- Step two** From the lining fabric cut a piece 28x20cm (11x8in) for the pocket lining.
- Step three** Place the rest of the lining fabric and cork fabric right side (RS) together then place the template centrally on top and cut around it through both layers for the outer and lining.

## ATTACHING THE MAGNETIC CLASP

- Step one** Transfer the magnetic clasp markings from the template onto the fabric. Mark the 'male' part of the clasp on the RS of the lining piece at the top part of the clutch.
- Step two** Mark the 'female' part of the clasp on the RS of the cork on the bottom of the clutch.
- Step three** Attach the clasp parts following the manufacturer's instructions.

## MAKING THE INNER ZIP POCKET

- Step one** On the main lining piece mark a central horizontal line 20cm (8in) long, positioned 32cm (12½in) from the bottom edge and centrally across. **01**
- Step two** Draw a 15cm (6in) horizontal line on the wrong side (WS) of one short end of the pocket lining positioned 2.5cm (1in) from the top and centrally across. This is the cutting line.
- Step three** Draw a sewing line box around this 5mm (¼in) outside the cutting line with short diagonal lines at the corners of the box. **02**

- Step four** Place the pocket lining RS together with the main lining piece, lining up the top of the pocket piece with the line you previously drew on the main lining piece. Pin into place. **03**
- Step five** Sew together on the stitching line. **04**
- Step six** Carefully cut along the cutting line and along the diagonal lines at each corner.
- Step seven** Poke the pocket lining piece through the gap to the back of the main lining and press.
- Step eight** Pin the zip RS up underneath the gap so the teeth show through it.
- Step nine** Sew the zip in place around the rectangle, about 3mm (¼in) from the edge. **05**
- Step ten** Turn the main lining over WS up then fold the pocket lining in half RS together so the raw edges at the top meet above the zip. Sew together across the top and down the sides. **06**

## ASSEMBLING THE CLUTCH

- Step one** Place the lining RS together with the cork and sew together all the way around, leaving a turning gap in the centre of one side.
- Step two** Turn RS out then press.
- Step three** Topstitch all the way around.
- Step four** Fold the bottom part of the clutch up by 16.5cm (6½in) so the lining is RS facing then stitch together. Work on top of the stitching already worked.
- Step five** Attach the metal bag trim to the flap edge following the manufacturer's instructions.

# QUICK FIX

Frosty winter mornings are no match for The New Craft House's super-snuggly cowl scarf.

MAKE YOUR OWN IN UNDER AN HOUR!



*"Any soft or plush fabric such as velvet, fleece, faux fur or sheepskin works well for this cowl. Choose a large button to add a flash of colour, too."*

## YOU WILL NEED

- Fabric: 140cm (55in) width x 60cm (24in)
- Large button
- Press fastener: one pair
- Matching thread
- Basic sewing kit

## NOTE

Use a 1.5cm (5/8in) seam allowance.

## MAKING A TUBE

**Step one** Fold the fabric in half lengthways right sides (RS) together and pin down the length.

**Step two** Stitch together down the long edge, leaving a 15cm (6in) turning gap in the centre.

**Step three** Move the seam so it runs down the centre of the fabric tube then press open.

## CREATING THE COWL

**Step one** Pin then stitch one short end of the fabric tube RS together, matching raw edges.

**Step two** Trim the seam allowance a little then clip the corners.

**Step three** Repeat this at the other short end

**Step four** Turn the fabric tube RS out through the turning gap.

## ATTACHING THE FASTENINGS

**Step one** With the cowl laid flat and with RS facing, place one half of the press fastener on the back of the bottom left hand corner and pin into place.

**Step two** Place the other half on the front of the bottom right hand corner and pin into place.

**Step three** Check the two halves of the fastener match up neatly then stitch them into place. Put your hand through the turning gap so you only stitch through one layer of the fabric.

**Step four** Stitch the button on the front of the bottom left hand corner so that it is directly behind the fastener, but again through one layer of the fabric.

**Step five** Fold the raw edges of the turning gap to the inside then slip stitch securely closed.

PSST

Turn to page 51 for fabric  
and styling ideas, and be  
sure to share your finished  
Bea Blouse with us using  
#simplysewingmag





# THE BEA BLOUSE

Sew a chic new style for your everyday wardrobe with **The Bea Blouse** in UK sizes 6-20, a vintage-inspired shift top with a bow detail and two sleeve lengths.

# THE BEA BLOUSE

As much as we love sewing statement dresses for special occasions, it's oh-so-satisfying to make classic, staple styles we can wear for everyday living, from work days to weekend brunches, too. So we're adding a chic new addition to our work-to-weekend wardrobe with this issue's Bea Blouse in UK sizes 6-20 (US 4-18/EUR 34-48), a vintage-inspired top with an easy-wear shift silhouette, pretty bow neckline detail and two sleeve lengths to choose from.

The blouse is designed for light-weight wovens, so we'll be playing with prints and textures to change up the look of our Bea – pick a floaty rayon or crêpe and for a feminine, drapery style, or choose a crisp cotton print for a more structured, work-ready look.

The step-by-step instructions will take you through sewing a simple shift top, inserting sleeves and adding a bow neckline detail.

Don't forget to share your finished Bea Blouse with us using #simplysewingmag!

## YOU WILL NEED

### ■ Fabric:

**Blouse A:** 115cm (45in) width fabric x 1.7m (2yds); 140cm (55in) width fabric x 1.5m (1¾yds) for all sizes

**Blouse B:** 115cm (45in) width fabric x 1.8m (2yds); 140cm (55in) width fabric x 1.5m (1¾yds) for all sizes

### ■ Matching thread

## FABRIC SUGGESTIONS

■ Light-weight woven fabrics such as cotton, cotton lawn, gingham, rayon or crêpe.

## GETTING STARTED

First pre-wash and dry your chosen fabric to allow for any shrinkage. Unfold the pattern sheets included in the pattern envelope, and find the line style for your size using the key provided. Follow these lines to cut out your pattern – it can be helpful to mark the relevant lines using a highlighter. Read through all the instructions before you start, get your sewing kit ready so you have everything you need to hand, press the fabric to ensure accurate cutting out, and you're ready to get started on the fun part – sewing your Bea Blouse!

PSST

*Make the bow neckline detail in a contrast print or colour for a statement look (it's a great stash-buster, too!).*

**BOW NECKLINE**  
Add a bow neckline detail for vintage-inspired style.

**EASY FIT**  
Features a classic shift bodice for a simple sew.

**TWO SLEEVE OPTIONS**  
Choose from capped or elbow-length sleeves.



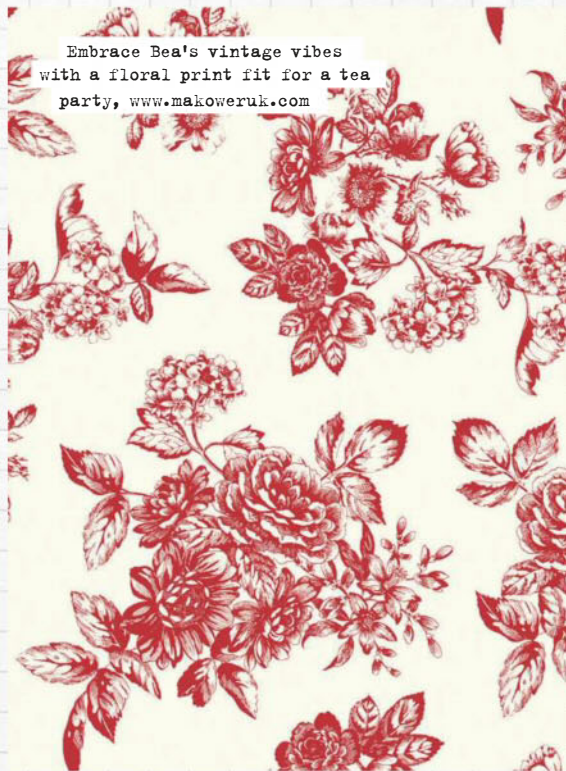

Embrace Bea's vintage vibes with a floral print fit for a tea party, [www.makoweruk.com](http://www.makoweruk.com)



Daisy, [www.makoweruk.com](http://www.makoweruk.com)



Gingham, [www.makoweruk.com](http://www.makoweruk.com)



Tonal Floral, [www.makoweruk.com](http://www.makoweruk.com)

**FABRIC INSPIRATION**

**SO BEA-UTIFUL**

From bold blooms and ditsy florals to workwear checks and classic gingham, Bea's simple style means anything goes.



Ocean/Fuchsia, [www.hantex.co.uk/cloud9](http://www.hantex.co.uk/cloud9)



Rose, [www.makoweruk.com](http://www.makoweruk.com)



Lagoon/Ocean, [www.hantex.co.uk/cloud9](http://www.hantex.co.uk/cloud9)

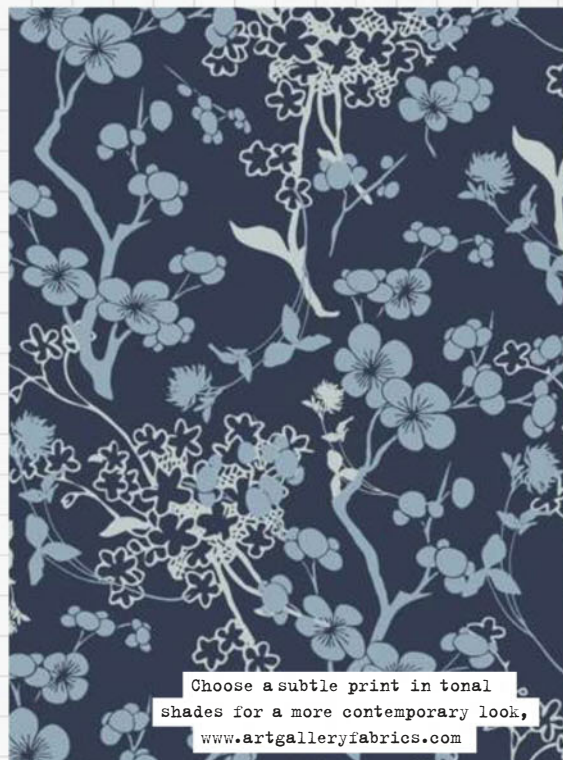

Choose a subtle print in tonal shades for a more contemporary look, [www.artgalleryfabrics.com](http://www.artgalleryfabrics.com)

WEAR IT WITH

**CHERRY PICKED**

A classic blouse calls for classic styling in bold cherry red.

*If you only buy one lipstick, make it scarlet-hued, £10, [www.marksandspencer.com](http://www.marksandspencer.com).*



*Finish off a vintage-inspired look with a red-hot mani. £2.99, [www.newlook.com](http://www.newlook.com)*



A statement tote bag that's roomy enough for fabric-shopping? Yes, please. £49, [www.debenhams.com](http://www.debenhams.com)



Forget power dressing – slouchy tailoring is our kind of workwear. £95, [www.gerryweber.com](http://www.gerryweber.com)



Try a new twist on a pencil skirt with a faux wrap detail. £9, [www.tesco.com/clothing](http://www.tesco.com/clothing)



*There's nothing a pair of black pumps won't go with, £16, [www.tesco.com/clothing](http://www.tesco.com/clothing)*



Photos: www.diy-couture.co.uk

## REBEL REBEL

**Rosie Martin's experimental dressmaking style has made her an advocate for the power of patternless. She shares why she'll always be a sewing rule-breaker.**

**R**osie Martin discovered patternless sewing before there was even a word for it. Since making her first garments as a teenager, she's taken a fearless, have-a-go approach to whipping up her own unique designs using fabric, imagination and a lot of trial and error – and all with no sewing patterns in sight.

It began when she learned to sew at school at the age of 12, although she's come a long way since those first tentative stitches on a sewing machine. "My teacher Ms Wilcox taught us the sewing basics. I'm pretty sure it was a nightmare teaching 30 disinterested teenagers how to use machines," Rosie says. "We made simple things like cushion covers and other square things!" As she neared her exams, though, she got into her stitching stride. "For our GCSE projects, we got to pick

a decade and design a garment influenced by that decade," she recalls. "I picked the 1970s and punk and made a red tartan dungaree dress and painted an anarchist sign on the front. It's remarkable how little I have changed! My parents bought me a sewing machine for Christmas when I was 15 and I was away!" The patternless sewing concept was still a far-flung ideal at that point, but Rosie was already seeking something that would allow her the same freedom.

"As a teenager I had strong ideas about particular pieces of clothing that didn't exist," she explains. "The only way to make these dreams a reality was to sew them myself, as what I wanted was often not available to buy." Living in the countryside, pre-internet, meant that access to patterns was extremely limited. "I would see them at the fabric shop

in town and they seemed irrelevant to me."

The first thing Rosie decided to attempt making herself was a pair of big, baggy, colourful trousers. "My friend drew out some simple diagrams in coloured biro showing me how to make trousers with a zip fly, and I gave it a go," she says. "My first experiences of sewing were really patternless, and that's probably what I thought sewing was! There wasn't really anyone to show me otherwise. So patternless sewing runs deep in my veins."

### AN IRRESISTIBLE SENSE OF FREEDOM

The lack of boundaries inherent in making without a sewing pattern tapped into Rosie's growing hunger for clothing that matched her individuality. "I love the freedom and the control that patternless sewing brings," she says. "I think originally I was quite a rough,

impatient sewist and patternless sewing suited my need to create and my carefree attitude." Over time, Rosie's technical skills have developed. "These days I sew in a more considered manner, but patternless sewing has grown with me," she says. "Originally, I didn't really know about 'the rules' of sewing, and, now that I do, I like that patternless sewing helps me to throw out 'the rules' and dive into making something that works for me.

I don't need someone else to have created a pattern, and I like that I feel confident to make things the way I want them."

At the core of Rosie's methodology is an understanding of how what we wear usually starts with a single, simple geometric shape. "Many homemade garments begin with a simple rectangle or a circle and are manipulated to fit the more interesting, varied shape of the human body," she says. "It doesn't take much – a few gathers here, a couple of darts there – to force a geometric shape into a beautiful one-of-a-kind garment."

## SEWING FOR ALL

The idea for DIYcouture, the fashion label Rosie is best known for, came about in 2007 when she struggled to buy an appropriate sewing pattern to make a piece of clothing for a friend. "It took a long time to choose a sewing pattern as they were quite old-fashioned and uninspiring," she says. "When I opened the pattern, I could see that it was explaining a very basic construction process in complex terms with barely any diagrams. The simplicity of the process did not come across in the medium – in fact, it seemed to be a barrier rather than an aid."

As a result, Rosie was flooded with "an overwhelming urge" to try composing her own simple sewing instructions. "I met so many people who told me they would love to make their own clothes but felt it was beyond their capability. I knew this wasn't the case," she says. "I felt that sewing patterns were not the best learning tool for beginners, as they sometimes look complex and technical. I wanted to make clothes-making accessible to anyone and everyone. It seemed to me that sewing needed to be explained in simple, visual terms in order to reach a whole world of people who would like to sew but lacked the confidence to begin."

Each design is kept as straightforward as possible to allow for as much adaptability as possible. "This is a limitation imposed by the way I am explaining how to construct the garments, and it is fun to work within this limitation," Rosie says. "The instructions need

to allow people the freedom to make adjustments as they go." Rosie's original How To guides are the heart of DIYcouture.

"I wanted to help make garment-making something that anyone could dip into, so that more people would be free to choose to create their own clothes," she says. "I wanted people to see that making clothes was an accessible activity, not something you needed a degree to do. That's how my

picture-based instructions were born. Sewing is a visual activity – basically joining large, flat, colourful shapes together – and I think it is best explained visually.

This sounds obvious now, but back in 2007 I hadn't come across any sewing instructions with full colour instructions, either photos or diagrams."

Rosie was also keen for the instructions to appeal to people who previously might not have thought garment sewing was for them. "I wanted the instructions to be fun and to comprehensively explain the garment construction process," she says. "I was hoping to give a full understanding of how a garment is put together – the order in which things need to be done – to empower people to create!"

In 2012 Rosie brought out her first book, *DIYcouture: Create Your Own Fashion Collection*, with Laurence King Publishing. It was only a matter of time before Rosie realised that her growing fascination with clothing shapes would form the basis for her next book. "The idea for my second book came to me whilst I was at the gym," she says. "Laurence King had asked me if I would like to write another and I had a few thoughts swirling around," she says. "The tutorials that I liked the best from my last book were the ones that took really simple shapes and manipulated them to fit the body. I think that's a really good way to learn to make clothes – like learning the primary colours or how to count from 1 to 10 as a kid."

Rosie had also recently been flipping through a sewing book and

**Right: Rosie's second sewing book, *No Patterns Needed*, uses simple, familiar shapes – rectangles, triangles and circles – to create garments with dozens of possible variations to play around with.**



Photos: Victoria Siddle. From *No Patterns Needed: DIY Couture from Simple Shapes* by Rosie Martin, published by Laurence King.

had seen a diagram of women's bodies categorised into a few different shapes – "triangle, rectangle, etc. It annoyed me a bit as I think the beauty of sewing is you can make whatever you want, regardless of whether society thinks it suits you. I thought, wouldn't it be great if we could take these shapes and become properly empowered through using them to create garments for our bodies, rather than having these shapes imposed on our

bodies? That was really the inspiration behind my second book *No Patterns Needed: DIY Couture from Simple Shapes*."

### COUTURE FASHION

Having previously worked as a stylist and costumier on music video shoots and as a machinist for Kylie Minogue's dance troupe, Rosie has an enduring passion for couture fashions.

"I have always found looking at images from catwalk shows really inspiring," she says. "They have a big budget and a platform to display their ideas. That's probably the most outrageous clothing can get and I love it." Fashions on the street also prompt ideas. "I'm not a big shopper, so I look at the clothes of people I see around me," she says. "People on the street mash things together in an

interesting way – mixing the top end with the everyday. 'La beauté est dans la rue' – beauty is on the street – is one of the mottos of DIYcouture. This is a passionate cry that beauty lies in each diverse human, it is not institutionalised or idealised."

With so much of her design work being concept-based, the bulk of the work happens in the form of thinking and mulling over possibilities. "I sort of don't mind where

I work on idea – it could be on the underground, in my head as I'm cycling, or sitting on my sofa," she says. Online inspiration also feeds Rosie's voyeuristic tendencies. "I actually love Sally's Charity

Shop Chic blog ([www.charityshopchic.net](http://www.charityshopchic.net)) where she buys ill-fitting pieces from charity shops and works her magic to transform them into something beautiful. I love the before and after and finding out about how she made the miracle happen!"

Rosie's current favourite design trends are deliciously dramatic. "Like the rest of planet earth I am of course loving the ruffle trend," she says. "I'm wondering if we've all been brainwashed by giant, ruffle-loving aliens in preparation for them landing on earth, but I'm rolling with it anyway." At the other end

of the scale, sportswear has caught her eye, too. "I'm loving the sportswear trend I seem to be seeing on lots of awesome fashionable people in London," she says. "I can barely ever catch up with trends as they move too quickly compared with the time I have to sew, but I'm hoping one day to have a few pairs of wonderful tracksuit bottoms I can wear out and about. I see some shiny wine-coloured ones with black piping." On that note, Rosie is also "really into mixed textures and sheer patches at the moment. I don't even know if this is a trend but I'm into it!"

### A DEVELOPING STYLE

Starting out sewing with the dauntless attitude of youth has equipped Rosie to handle most things that come her way. "Oh gosh... I see making mistakes as part of true lifelong learning. I've made loads of horrible things," she says. "I was a gung-ho clothing maker as a teenager and went through years of trial and error, which probably made me hardened to failure! I definitely cried over a pair of silver jeans with mirrored magenta trim I made when I was 18."

She has applied this same experimental, try-anything ethos to DIYcouture. "My initial aim with DIYcouture was to make a whole collection. I started by drawing about 50 things on paper and then decided to make them," she says. "It was definitely a process of 'I make mistakes so you don't have to',

"I HAVE ALWAYS FOUND LOOKING AT IMAGES FROM CATWALK SHOWS REALLY INSPIRING. THEY HAVE A BIG BUDGET AND A PLATFORM TO DISPLAY THEIR IDEAS."



If only we looked this stylish on laundry day! These projects from Rosie's debut collection offer endless ways to make them your own.

Photo: [www.diy-couture.co.uk](http://www.diy-couture.co.uk)



rather than 'I know what I'm doing'. I was trying to see if it was possible to make things, and often it wasn't. I made terrible things."

She admits that at times this was a painful process. "It can be heartbreaking to put all that effort in and to end up with a disgusting item," she says. "I don't think failed projects will ever be a thing of the past, though I must say as I've got older I seem more in tune with what will and won't work for me – both design-wise and materials-wise – and I guess my technical skills have improved so that my mistakes are more few and far between."

With so much experience behind her, we can understand why she votes for using "whatever technique works." She adds: "I'm a bit of a bias binding nut and I guess I will never get over the miracle of using it to create lovely curved edges." Simple pleasures in sewing are also at the forefront when it comes to her most-used kit. "My favourite sewing tools are pretty basic – tailor's chalk and a metre stick," she says. "I also love newspaper for hacking and altering paper patterns or for drawing out fresh ideas."

Rosie is equally impassioned and engaged in how she spends her free time. "I play the

drums and love making music with my band mates," she says. "I've recently started having a go at singing while I'm drumming, which is a lot of fun, mostly because I have no idea what I'm doing but am doing it anyway. I love walking and exploring the streets of London and this year I've got into swimming out in the wild as well. I think I've always had 'productive' hobbies, where I create something or do something almost work-like (like sewing) and I'm actually just enjoying this pure, primal kind of fun!"

Before Rosie dashes off, there's time for just one more question. How would you describe your style? Hesitating for barely a moment, Rosie declares: "Evolving!" We can't think of a better way to be.

**See more of Rosie's freehand fashion projects at [www.diy-couture.co.uk](http://www.diy-couture.co.uk)**

Top left: Rosie sunbathes in a shirt made from fabric with a quirky hands print she designed herself. Right: DIY this season's ruffle trend with a statement frock from Rosie's *No Patterns Needed* book.



Some of the designs in this section employ the positive power of this commanding shape, building clothes from pieces of fabric and using edge

We can also think about this in terms of making clothes. Most of us have worn premade garments our whole lives. Many of us then experience a moment when we become curious about the possibility of constructing our own clothing from scratch. It's a new way of making

With knowledge of basic techniques and processes, and with the confidence to play and experiment, I hope that this book can help you approach clothes-making boldly and creatively.

Beauty

## ROSIE'S TOP STITCHING ADVICE

"I think the best advice I've been given is 'don't worry!' This definitely applies to pattern-free sewing. Trust in what you already know. It doesn't matter if you do things your own way. 'Pattern free' might imply you're alone in a vacuum attempting to be a genius, but you're not alone – you have fabric, something to measure with, clothes you already wear, and your body. To twist a famous quote from *RuPaul's Drag Race*, 'start relying on that body!' You can measure your waist, therefore you can make a waistband that fits. Your body is your blueprint, so work it!"

SEW  
OVER  
IT



New fabrics added every week!

£2.50 UK P&P      [sewoverit.co.uk/shop](http://sewoverit.co.uk/shop)  
FREE for orders £75+      0207 326 0376

[girlcharlee.co.uk](http://girlcharlee.co.uk)  
Knit Fabric Specialists!



100s of exclusive knit fabrics,  
indie patterns & more!

10% off with code SIMPLY - Free UK shipping over £50

— THE —  
CREATIVE  
**CRAFT**  
SHOW

Manchester, EventCity 1-3 February

Glasgow, SEC 8-11 March

Birmingham, NEC 15-18 March

London, ExCeL 19-21 April

The **Stitching, Sewing & Hobbycrafts** Show  
back with a brand new look

Book now  
and save £4\*  
on the door price  
using code

**TM20**

Sewing  
Stitching  
Papercraft  
Knitting  
Jewellery  
& more!

Buy tickets at [www.ichfevents.co.uk](http://www.ichfevents.co.uk)  
or call Ticket Hotline 01425 277 988

   #CreativeCraftShow

\*All prices relate to a one day adult on the door ticket. Manchester one day tickets cost £10, Glasgow one day tickets cost £10.50, Birmingham one day tickets cost £14, London one day ticket cost £12. Phone lines open 9am to 5pm Monday to Thursday (4.30 Friday) - standard tariffs apply. Offer valid until 5pm on the Monday prior to the show, & cannot be used in conjunction with any other offer. Use code TM20 at checkout

WORKSHOPS, DEMONSTRATIONS & MUCH MORE



GET THIS FABRIC  
WHEN YOU  
SUBSCRIBE  
TODAY!  
p18

# SWEET DREAMS

Make **Jennie Jones'** quick-sew piped sleep mask and bag in an afternoon (and still have time for a nap).



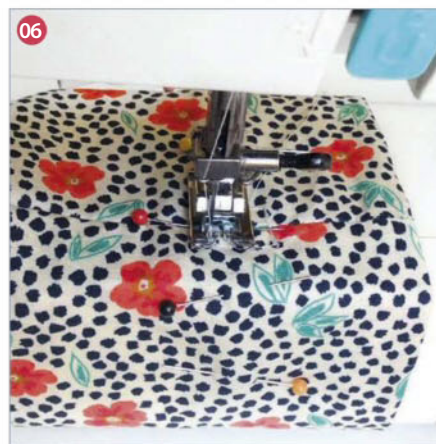
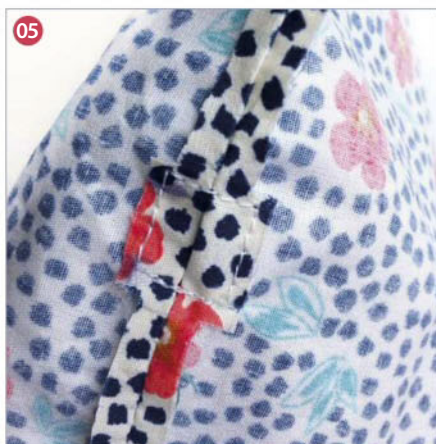

## YOU WILL NEED

- Main fabric: one fat quarter
- Contrast fabric: one fat quarter
- 2oz wadding: 25x15cm (10x6in)
- Narrow piping cord: 45cm (18in)
- Elastic: 1cm (3/8in) width x 25cm (10in) length
- Ribbon: 5mm (1/4in) width x 80cm (32in) length
- Matching thread
- Basic sewing kit

## FABRIC

Mist Flora Luminous and Tartan Teal from the Indie Folk collection by Pat Bravo for Art Gallery Fabrics. For stockists visit [www.hantex.co.uk/agf](http://www.hantex.co.uk/agf)

## NOTES

- Use a 1cm (3/8in) seam allowance.
- Download the template from [www.simplysewingmag.com/downloads](http://www.simplysewingmag.com/downloads)

## CUTTING OUT

**Step one** Download the template and cut it out.

**Step two** From the main fabric cut:

Eye mask: cut one piece using the template.

Elastic casing: 5x50cm.

Bag: two pieces 18x16cm (7 1/8x6 3/8in).

**Step three** From the contrast fabric cut:

Eye mask lining: cut one using the template.

Piping strip: 3x45cm (1 1/4x18in).

Bag lining: two pieces 8x16cm (3 1/8x6 3/8in).

## MAKING THE SLEEP MASK

**Step one** Fold the piping strip in half lengthways with wrong sides (WS) together and place the piping cord inside. Stitch together down the length 1cm (3/8in) from the edge.

**Step two** Pin the covered piping around the edge of the main fabric mask shape with right sides (RS) together and matching raw edges. **01**

**Step three** To join the short ends, trim down the cord so it meets the other end. Fold over one fabric short end and tuck the other inside it. **02**

**Step four** Sew the covered piping into place.

**Step five** Fold the elastic casing fabric strip in half lengthways with RS facing then sew together down the length and turn RS out.

**Step six** Thread the elastic through the casing and stitch across both ends to hold the elastic.

**Step seven** Pin the elastic casing centrally across the sides of the mask.

**Step eight** Pin the mask lining RS together on

top and stitch together close to the piping cord, leaving a turning gap on one side. **03**

**Step nine** Turn RS out, slip stitch the gap closed.

## MAKING THE BAG

**Step one** Place the long edge of one lining strip RS together across the top short edge of the main bag, matching the top short raw edges.

**Step two** Stitch together across the top then turn under the other raw long edge of the lining piece by 1.5cm (5/8in).

**Step three** Repeat this with the other main bag and lining strip.

**Step four** Place the joined pieces RS facing and stitch together down the sides, leaving a 1cm (1/2in) gap on each side positioned 4cm (2in) down from the seam. **04**

**Step five** Press the side seams open then stitch a box around the gaps. **05**

**Step six** Turn the bag RS out, tuck the lining strip into the bag and pin into place.

**Step seven** Sew two lines all the way around to make the casing channel, positioning them at the top and bottom of the boxes. **06**

**Step eight** Cut the ribbon in half and thread one length through the casing, then knot the ends.

**Step nine** Thread the other length through but starting and finishing at the opposite side.

**Step ten** Fold your mask in half, pop it into the bag and pull the ribbons to close.

Nº 08

BULLION KNOT

# STITCH

## library

Pretty up your space with **Mollie Johanson's** hanging decoration stitched with bullion knot roses.



CUT OUT & KEEP

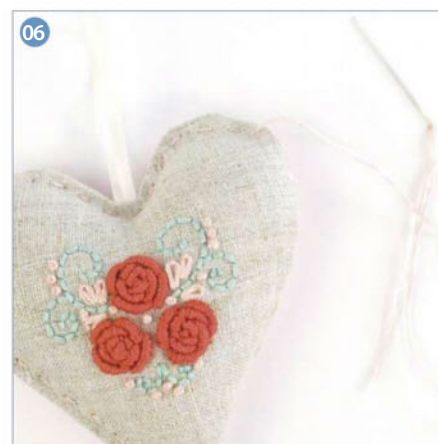
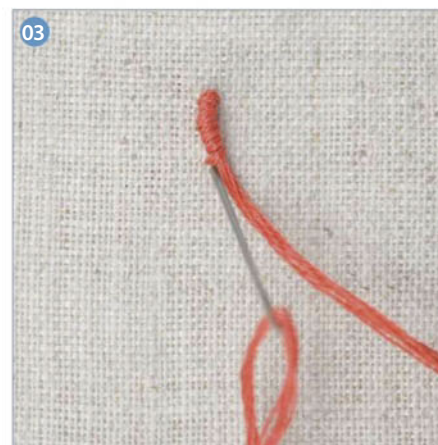
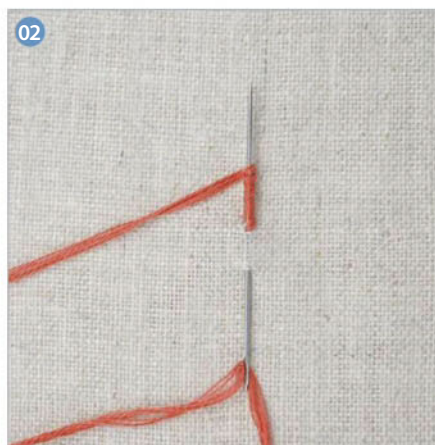
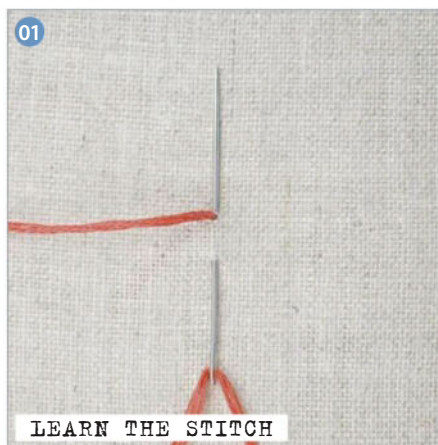

## YOU WILL NEED

- Main fabric: 20x20cm (8x8in), heart front
- Backing fabric: 20x20cm (8x8in), heart back
- Stranded cotton: dark coral, green and pink
- Narrow ribbon: 20cm (8in)
- Polyester fibrefill
- Matching thread
- Basic sewing kit

## NOTES

- Use a 1cm (3/8in) seam allowance.
- Download the template from [www.simplysewingmag.com/downloads](http://www.simplysewingmag.com/downloads)

## WORKING A BULLION KNOT

**Step one** Bring the needle up through the fabric where you want the knot to start.

**Step two** Take the needle down through the fabric a short distance away then bring it back up again near the point where the thread first emerged, leaving the needle in place. **01**

**Step three** Wrap the working thread around the needle as many times as it takes to make a wrapped coil that is as long as the knot you are forming, keeping the thread as smooth as possible. If you want to make a bullion knot with a curve, the wrapping should be a little longer than the stitch gap. **02**

**Step four** Hold the wrapped thread and carefully pull the needle and thread through. If the wrapping is too tight to pull the needle through then twist it a little to loosen it. As you pull the thread, the wrapped knot will come back and lay on the fabric. **03**

**Step five** Bring the needle back through the fabric to complete the bullion knot.

## MAKING A HEART ORNAMENT

**Step one** Download and print out the template.

**Step two** Place your main fabric right side (RS) up on top with the template centrally beneath then trace over the motif and the heart outline.

## WORKING THE EMBROIDERY

**Step one** Use six strands of stranded cotton for

all the stitching.

**Step two** Start by stitching the roses as bullion knots in dark coral. Make a tiny bullion knot for the centre, then add more knots to fill in the circle, making them longer as you go.

**Step three** Work the swirls in green back stitch.

**Step four** Use pink stranded cotton to work the small dots in French knots and the petal shapes, which are worked as detached chain stitches.

## MAKING THE HEART

**Step one** Cut out the drawn heart shape then use this as a template to cut out a heart shape from the backing fabric. **04**

**Step two** Tie the ends of the ribbon together.

**Step three** Pin the heart front and back right sides (RS) together with the loop of ribbon between the layers. The knot should stick out of the top centre of the heart.

**Step four** Sew the heart front and back together, leaving a turning gap on one side.

**Step five** Clip the points and curves. **05**

## FINISHING OFF

**Step one** Turn the heart RS out, fold the edges of the turning gap to the inside and press.

**Step two** Stuff lightly then slip stitch the turning gap closed.

**Step three** Stitch around the edge of the heart with running stitch and three strands of pink stranded cotton to decorate. **06**



**FABRICATE**  
ROBERTTOWN

Stockists of Designer Fabrics, Including Atelier Brunette, Art Gallery, John Louden, Liberty and Robert Kaufman

**15% OFF NEXT ORDER** WITH CODE **SSM15**

**FABRIC SEWING PATTERNS KITS  
HABERDASHERY WORKSHOPS**

[FABRICATESHOP.CO.UK](http://FABRICATESHOP.CO.UK)

164a Roberttown Lane Liversedge West Yorkshire WF15 7LT

*Simply*  
**Sewing**  
FRESH IDEAS WITH FABRIC

TO LEARN MORE ABOUT ADVERTISING OPPORTUNITIES  
PLEASE CONTACT TIFFANY JACKSON  
TIFFANY.JACKSON@IMMEDIATE.CO.UK  
0117 300 8203

**Textile Holidays France**  
Creative Holidays and Sewing Retreats in S. W. France



Holidays include "Learn to Sew in France" and "Creative Textiles" and are held in my studio overlooking the French Countryside.  
**Comfortable accommodation.**  
**Discount for groups of friends.**

[www.textileholidaysfrance.com](http://www.textileholidaysfrance.com)  
[info@lejardinduburger.com](mailto:info@lejardinduburger.com)

*new* **Watersmeet 2.0 Papercrafting Edition** **store away** *Deluxe*

**NATURAL OAK** **OAK**  
**VANILLA** **WHITE**

Unit pictured in Natural Oak finish

**Really Useful Storage Cabinet 190cm (KITD14)**  
Regular Price £659.10 (excluding delivery)

**Magazine Offer**  
**£570 (SAVE £89.10)**

Mainland UK delivery £30 extra  
**Offer Coupon - D14SAVE**



Magnetic Panel  
12x12  
A4  
Space for cutting machines  
Folding Work Table  
A3

**Storeaway Deluxe - Watersmeet 2.0 Papercrafting Edition**  
Regular Price £1795 (excluding delivery)

**Magazine Offer**  
**£1495 (SAVE £300)**

Mainland UK delivery £50 extra  
**Offer Coupon - WMPE816**

84cm or 33 inches  
190cm or 74 1/2 inches

Offer expires end of month following magazine publication (eg. Jan Issue expires end of Feb)

Please note all furniture items are supplied self assembly - assembly can be arranged please call for further details and charges

**Call us free on 0800 048 8606 - [www.storage4crafts.co.uk](http://www.storage4crafts.co.uk)**  
[mail@storage4crafts.co.uk](mailto:mail@storage4crafts.co.uk)



Dara (right) and her friend Alanna have collaborated to create Square Cut batiks, their own brand of hand-dyed homewares.

Photos: www.bywayofblog.com



Dara and Alanna fell in love with batik at an evening class: "After the three hours were up, we were hooked."

# TALES OF THE UNEXPECTED

We meet Dara Magagnoli, whose search for inspiration led her to launch By Way Of – a powerful storytelling blog celebrating creative women – and kick-start a venture of her own.

Written by Judy Darley.

**D**ara Magagnoli was on the look-out for inspiration for her own creative pursuits when she dreamed up the concept for By Way Of ([www.bywayofblog.com](http://www.bywayofblog.com)), a platform for creative women to tell their stories. The site has since become a treasure-trove of authentic, inspiring content, with artists, teachers, comedians, embroiderers, sewists and writers sharing what drives them.

"What began as a quest for honest inspiration has blossomed into a storytelling blog," confesses Dara on By Way Of's About section. "I want to shine a light on women who are successful by being creatively uncompromised. I want to learn where their ideas come from, take a look at the road they travelled to get here, and provide a space for their stories to be told."

## A NATURAL CURIOSITY

It took us a while to pin down Dara for a chat – like most makers we know, she's busy keeping multiple ventures on the go, including a full-time job, a new product line, and an endless round of interviews for the blog. We felt it was time to turn the tables and ask Dara some questions about her own enduring urge to make, connect and collect.

"I've always been curious about and drawn to raw and creative characters – people who might be a little rough around the edges or have a quiet determination about them," Dara admits. "A friend and I would talk regularly about creative people we had learned of on social media or design blogs, talking about how inspired we were by them and what they do, but always wondering: HOW? How do they approach their creativity so unapologetically,



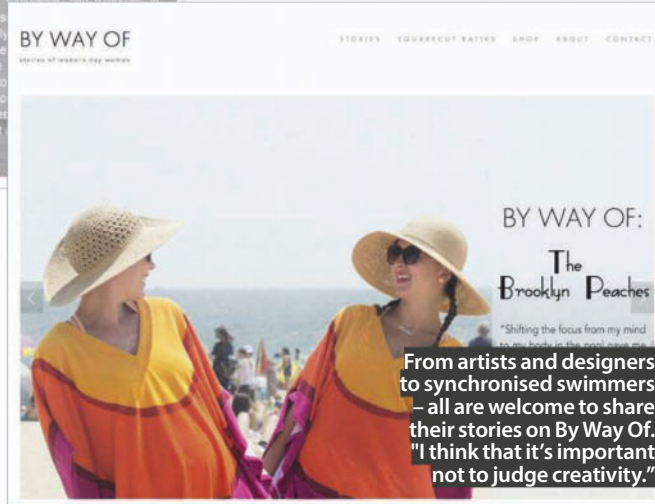
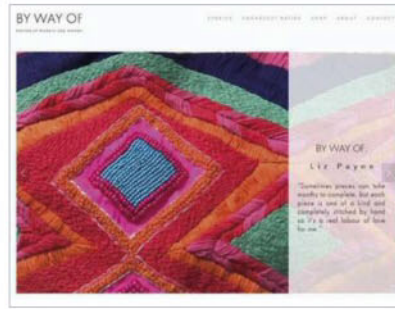
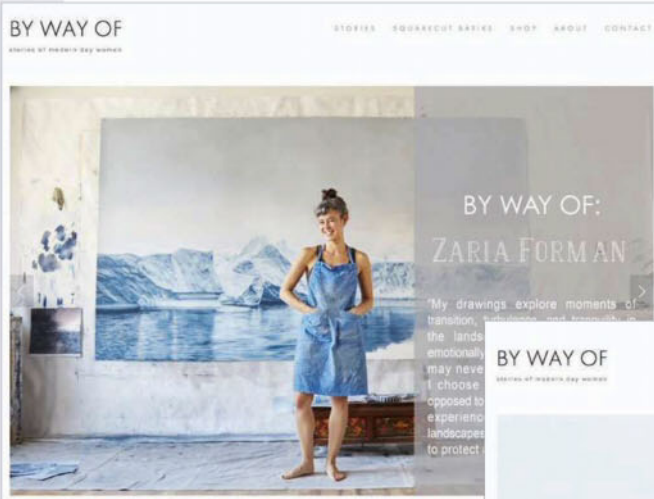

From artists and designers to synchronised swimmers – all are welcome to share their stories on By Way Of. "I think that it's important not to judge creativity."

so authentically? What gets them out of bed in the morning?" In 2014, Dara set out to find out the answers to those questions from the women who inspire her, and By Way Of was born. "My goal was to tell a good and messy story, one that is real and told in their own words, or sewing, or art, or photography, or movement," Dara says. "Interviewing them gave me the opportunity to learn about what drives of all these creative women."

### FORGING CONNECTIONS

This desire to bring to light the creative achievements of women who have found success in a variety of fields has only grown stronger and more meaningful with time. "As I get older I find my female relationships to be more and more important," says Dara. "And as I learn about women who make creativity a priority, I find connection." It also fuels Dara's own craving to make and create. "Spending time working with my hands is very important to me and my overall happiness and wellbeing," she comments. "It can be easy to fall victim to feeling like if it isn't 'successful' or making me money that it isn't worth it. Celebrating women who make it a priority regardless of the end result has been really important to my own process. It makes it more about the road, less about destination. I feel a bit cheesy saying that, but it's true."

When it comes to expressing her own creativity, Dara describes herself as "sort of a wanderer. It can come out in the kitchen or in the woods. I love to sew, make jewellery, weave, refinish furniture, decorate... There are endless opportunities for creativity!" One of

the key values of the blog for Dara is the way in which it draws attention to the things that women who make have in common.

"It's important to me that it highlights our similarities rather than our differences," she says. "I think women can sometimes lose sight of the built-in connectivity we have, and fall into competitive behaviours. Talking to women who are so open to sharing their stories with a perfect stranger in order to

"My goal was to tell a good and messy story, one that is real and told in their own words."

make her creative pursuit come to life is what it is all about. We are all here to support each other and raise each other up."

Finding and selecting the women she wants to include is equally positive, both in ethos and experience. "It started with friends and friends of friends, but one day I decided to just reach out to women that I didn't know but had been following online and admiring for some time," she explains. "Their willingness to be involved was so incredible. Women were absolutely delighted to tell their stories, to invite us into their home and studios, and to offer really thoughtful conversations."

Dara's chosen women have an impressive breadth of talents and skillsets, and this variety and diversity – along with a shared



The colourful, tactile work of textile artist Liz Payne is one of our favourite discoveries from the By Way Of blog – read our interview with her on page 75.



Photos: www.bywayofblog.com



During their month-long stay in Cambodia, Dara and Alanna "were lucky enough to learn more about natural dyeing from true masters."



enthusiasm for their chosen pursuit – is vital to Dara's remit. "They don't fit into categories or subscribe to any particular lifestyle," says Dara. "The thread that connects them is their authenticity and drive. Some may even challenge the definition of what it means to be creative, and that is the goal. I think that it's important not to judge creativity."

Instagram has been a vehicle for building links and spreading the word about By Way Of, along with Dara's new venture. "I have connected with many women for interviews

"OUR PRODUCTS ARE ALL DESIGNED, PRINTED, AND DYED IN SMALL BATCHES IN OUR BROOKLYN STUDIO."

on Instagram, and now with Square Cut batiks, I find it to be an invaluable way of sharing."

### BEAUTIFUL BATIKS

Square Cut batiks are a new chapter in By Way Of's own story, as Dara recently added a shop tab on the blog selling the batik-dyed scarves, homewares and other covetable items she produces in collaboration with her friend and colleague Alanna Parsons. It's a great example for the creative energy simmering within Dara herself. "Over a year ago, Alanna and I took an evening batik class in Brooklyn, and, after the

three hours were up, we were hooked," she says. "We started experimenting with natural dye and wax resist on weekend afternoons with some pretty exciting results."

The process draws on traditional batik dyeing methods, with one appealing difference. Dara, it transpires, is a collector of more than inspiration. "We bring our own modern take by designing patterns using found objects for printing," she explains on the website. "To make a batik, selected areas of the cloth are blocked out by brushing, stamping, or drawing hot wax over them, and the cloth is then dyed. The parts covered in wax resist the dye and remain the original colour. Our products are all designed, printed, and dyed in small batches in our Brooklyn studio. Each piece is completely unique."

The first items they used were square cut nails, hence the name of the collection. It's clear to see the nails' role in the design, but, cleverly, if you weren't aware of this detail it would simply appear to be a quirky, dappled, repeating pattern. The eco-friendly aspect is also important. "Cottons and linens are in our current rotation, but we are interested in hemp as well. With full-time jobs, it can be hard to fit in sewing time in addition to the printing, dyeing and laundering, so it is great to have talented and trusted friends to go to."

### THE ALCHEMY OF COLOUR

In May 2016, an opportunity came up to spend a month in Cambodia travelling, teaching and adding new textiles skills to their repertoire.



The pair are hoping to add complementary naturally dyed pieces to their existing indigo collection. "The great thing about natural dyes is they don't clash."

The pair understandably leapt at the chance. "It was incredible!" exclaims Dara. "While we were there we visited the Institute of Khmer Traditional Textiles (IKTT) in Krong Siem Reap where we were lucky enough to learn more about natural dyeing from true masters. We brought that knowledge home and have been working full-steam ever since." They also gained experience in transforming natural ingredients into fabric dyes. "We used prohut bark to create yellow and added a solution to oxidize this and turn it to green," says Dara. "We sourced amazing silk from silk worm cocoons, and had fun grinding up discarded nests of the lac insect, which creates red."

Her animation about the product line is contagious. "We are really excited about Square Cut batiks right now!" she says. "We have been educating ourselves on other natural dye processes and look forward to continuing to experiment with natural dyes. We love indigo, but can't wait to offer a full spectrum of plant-derived colours to our line."

Dara is a keen beachcomber and nature trail enthusiast, which has the potential to feed into the range. "I live for collecting things in the woods or on the beach," she says. "This past year I have been really into arranging my finds in colour gradations – rainbow earth samples from Zion National Park, obsidian from Escalante, Utah, mother of pearl from beaches on Long Island. The best colours, lines, and textures are all found in nature."

After a natural dyeing class with the Dogwood Dyer at the Fashion Institute of

Technology (FIT) in New York, Dara has a wish list of the dyes she and Alanna would love to try. "Madder Root, Cochineal, Osage Orange, Logwood, and of course, our current love Indigo, are all dye stuffs we're excited to play with," she says. "We are also interested in trying out avocado pits, which yield a dusty rosy peach colour. The great thing about natural dyes is they don't clash."

### PERFECT HARMONY

The aim is to create batik fabrics that will work in collaboration with their indigo creations. "We think the spectrum will be beautiful and complementary to our indigo pieces," she says. "The reason we started with indigo was because you do not need to mordant first. So adding in that process is new to us!" Mordant is a fixative that binds dyes to fabrics and stops them running – very important when sewing beautiful things you want to last!

Once the fabrics are dyed, they're ready to be reinvented as Square Cut products, most of which Dara and Alanna sew themselves. "We don't have a serger, so we outsource this to two incredibly talented women," she explains. "We recently had a custom tablecloth sewn by a real master, Jen Fairfield. We dyed three large panels which she sewed together with flat-felled seams and mitred corners. It was gorgeous." In our opinion, that's just another way of spreading the code of sisterhood at the heart of By Way Of. A beautiful idea, put into practice and achieved with flying colours.

See more at [www.bywayofblog.com](http://www.bywayofblog.com)

## BY WAY OF BRILLIANCE

Meet one of the talents picked out by Dara to feature on the By Way of blog, Australian artist Liz Payne.

"Dara approached me last year for the interview after seeing my work," she tells us. "My background is in visual arts and I was always creating when I was growing up, always sewing, knitting, beading necklaces and so on. I am, and always have been, intrigued and fascinated with the beauty of textiles from around the world. Upon returning home to Sydney from living overseas in London, where I'd been working as a graphic designer, I started to explore the idea of combining my background in Visual Arts and my experience as a designer, with my love of all things 'craft' from my childhood and my love of textiles."

It's a choice that's led her to creating artworks that sizzle with rainbow spectrums, yet contain all the calm and patience that comes from hours of piecing, sewing and embellishing. "I like to see working with thread as just another medium, and I use it incorporated with paint, beads and sequins to produce artworks that are a fusion of all these things," she says. "I think it's been five years since my work started to transition to what it is today, but in a way I feel like I've just been leading to this point."

Joining the By Way Of tribe has been an enriching experience, she says. "It's rewarding to be a part of something like By Way Of that tells it like it is," she explains. "Telling your story – the good and the bad – is all part of what makes us different and contributes to where we get to today."

Find Liz at [www.lizpayne.com](http://www.lizpayne.com), on Instagram @lizpayne, and, of course, on the By Way Of blog.



INCLUDES  
PATTERN  
GIFTS

# BACK ISSUES

ONLY  
**£6.99**  
INCLUDING  
FREE UK P&P



## ISSUE 37

Make a stylish jumpsuit, dinner table accessories, deer toy, a pleated clutch and overlay party skirt.



## ISSUE 36

Sew a ruffle party dress, quick-sew gifts for all the family and on-trend decorations for Christmas.



## ISSUE 35

Start making for Christmas with a Tilda stocking, gift ideas, advent bunting and 6 new looks for you.



## ISSUE 34

Sew the Adele Dress, Lara Set and Overnight Bag, make a child's bedroom set and try embroidery.



## ISSUE 33

Make floral bedroom accessories, a kimono-style top, asymmetric tee, clutch bag and baby bibs.



## GET ORGANISED

Each slip case can hold a year's worth of magazines (13 issues) and ensures your growing collection remains in perfect condition for future reference. To order a slip case please visit [www.buysubscriptions.com/binder](http://www.buysubscriptions.com/binder)

## 2 WAYS TO ORDER

Visit the website: [www.buysubscriptions.com/backissues](http://www.buysubscriptions.com/backissues)  
or call us on **03330 162 149**

\*Lines open weekdays 8am-6pm, Saturday 9am-1pm. Overseas please call +44(0)1604 973 758. Calls will be charged at your local call rate, calls from mobiles may vary. EUR price £6.99, ROW price £7.99 USA £7.99. Binder price EUR £9.60, ROW £11.50. All prices include p&p. All orders subject to availability. Please allow 28 days for delivery.

Never miss an issue again, turn to page 18 and subscribe today!

# LIFE HACK

Tick off a New Year's resolution and tidy up your workspace with **Jessica Entwistle's** organiser made from a pair of jeans.



# DENIM UPCYCLE



## YOU WILL NEED

- Denim jeans
- Cotton backing fabric: see instructions for details
- Dowel: 12mm (½in) diameter x length to fit your organiser
- Twine: 150cm (60in)
- Matching thread
- Basic sewing kit

## CUTTING OUT

**Step one** Open out one leg of your jeans by cutting it so that the stitched inner seam is in the middle of the cut denim piece. Trim it into a rectangle as big as the jeans leg will allow. This will form the backdrop for the pockets.

**Step two** Cut off the belt loops, back pockets and front pockets.

**Step three** Cut the backing fabric to the same size as the denim rectangle.

## MAKING THE POCKETS

**Step one** Lay the cut off pockets and belt loops on top of the denim rectangle, moving them until you are happy with the positioning. **01**

**Step two** Once you've laid these out you may find you need to make additional pockets. Cut these to the size you need from the remainder of the jeans, adding a 1cm (¾in) hem allowance.

**Step three** We made one long pocket to go across the bottom of the organiser from a jean leg. We added one made from a front pocket piece and a smaller one from a leg.

**Step four** To make each new pocket, turn the raw edges under by 1cm (¾in) to the wrong side (WS) and press.

**Step five** Topstitch the top turned-under edge into place, using contrast thread if you prefer.

**Step six** You can add belt loops to the fronts of

the pockets for interest. **02**

## ASSEMBLING THE ORGANISER

**Step one** Pin the pockets and belt loops to the denim rectangle, making sure you pin at least 3cm (1¼in) away from the long vertical raw edges and the bottom edge. Leave a minimum of 10cm (4in) at the top to allow for the seam allowance and the dowel casing. **03**

**Step two** Sew the pockets and loops in place then press all over.

**Step three** Pin the backing fabric and the sewn denim rectangle right sides (RS) together.

**Step four** Stitch together all the way around using a 1.5cm (⅝in) seam allowance, leaving a turning gap in the centre of the top edge.

**Step five** Clip the corners then turn RS out, pressing the edges of the turning gap under.

**Step six** Slip stitch the turning gap closed.

## ADDING THE CASING

**Step one** Fold the top of the organiser over by 4cm (1½in) to the WS and press.

**Step two** Stitch the folded edge into place close to the seamed edge to make the casing.

**Step three** Push the dowel through the casing.

**Step four** Knot the twine at either end of the dowel for hanging, tucking the raw ends inside the casing to finish. **04**



# RIGHT AS RAIN

It's time to raid your scraps stash –  
**Rebecca Reid's** simple-sew cushion  
is too pretty to save for a rainy day.



**BUY THIS KIT!**

*Sewing*  
**QUARTER**

See this demonstrated  
live on air on  
20th January 2018 \*

Live on  
**Freeview 78**

\* Visit page 15 for special  
offers and T&Cs

# RAINDROP CUSHION

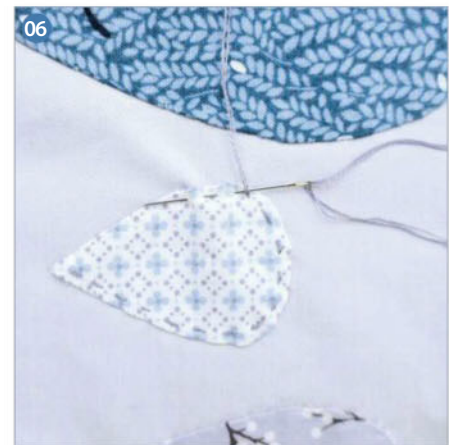

## YOU WILL NEED

- Background fabric: 45x90cm (18x36in)
- Appliqué fabrics: a mixture of fabrics measuring 60x60cm (24x24in) in total
- Freezer paper: 50x38cm (20x15in)
- Stranded cotton
- Zip: 35cm (14in)
- Cushion pad: 40x40cm (16x16in)
- Basic sewing kit

## NOTES

- Download the templates from [www.simplysewingmag.com/downloads](http://www.simplysewingmag.com/downloads)
- We have used freezer paper for our appliqué. This is plastic coated on one side so will temporarily stick to fabric without marking it. The advantage is that it stays in place whilst you are tacking the fabric shapes around it so you get a neat curved edge more easily. You can use ordinary plain paper instead but you would need to tack this in place before you stitch the fabric around it.
- Freezer paper is available from [www.sewingquarter.com](http://www.sewingquarter.com)

## CUTTING OUT

- Step one** Download the four raindrop templates.
- Step two** Place the freezer paper on top and trace around then cut out the raindrops: Raindrop A: trace one with the features on it. Raindrop B: trace six. Raindrop C: trace six. Raindrop D: trace two.
- Step three** Cut the background fabric into two pieces, 43x43cm (17x17in) for the front and back.

## EMBROIDERING THE LARGE RAINDROP

- Step one** Cut a 20x20cm (8x8in) piece of fabric. Place this right sides (RS) up over the Raindrop A template and trace the features.
- Step two** Embroider over the lines in backstitch using four strands of stranded cotton. <sup>01</sup>

## MAKING THE RAINDROPS

- Step one** Press the Raindrop A template, shiny side down onto the wrong side (WS) of the embroidered fabric making sure the features are positioned correctly.
- Step two** Cut the fabric 5mm (1/4in) outside the template and snip into the curved edges. <sup>02</sup>
- Step three** Fold and tack the edges of the fabric onto the paper. <sup>03</sup>
- Step four** Repeat this for the other raindrops.

## ATTACHING THE RAINDROPS

- Step one** Place the cushion front fabric RS up

then place the raindrops RS up on top.

- Step two** Refer to the photograph for positioning then pin them into place.
- Step three** Using a small neat slip stitch, sew each raindrop to the cushion front fabric. <sup>04</sup>
- Step four** Press then remove the tacking stitches.

## FINISHING THE DESIGN

- Step one** Make a small slit down the centre of the back of the raindrops, making sure you only cut the background fabric.
- Step two** Carefully pull out the paper raindrops through the slits then press. <sup>05</sup>
- Step three** Using two strands of stranded cotton, work a neat running stitch just inside the edge of each raindrop. <sup>06</sup>

## MAKING THE CUSHION COVER

- Step one** Pin the cushion front and back RS together on the bottom. Stitch 3cm (1 1/4in) from each edge using a 1.5cm (5/8in) seam allowance.
- Step two** Using your longest machine stitch, stitch between these seams then press open.
- Step three** Pin the zip RS down centrally on top of this seam. Stitch into place using a zip foot.
- Step four** Undo the long machine stitches you worked between the side seams.
- Step five** Place the front and back RS together and stitch together around all three sides.
- Step six** Clip corners then turn RS out and press. Put the cushion pad inside to finish.

QUICK  
PROJECT  
USE 1 FAT  
QUARTER



## SIT, STAY!

Make a four-legged friend to guard your door in durable denim with **Jennie Jones'** doorstop how-to.

# FAST FAT QUARTER

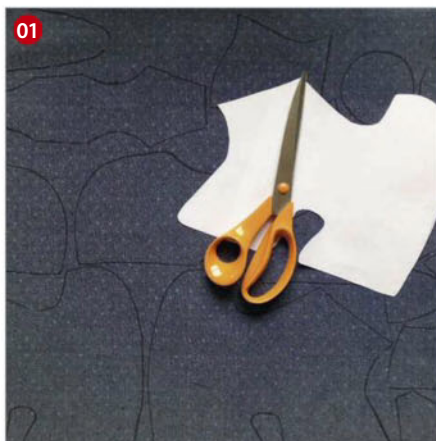

## YOU WILL NEED

- 1 fat quarter
- Ribbon: 1m (1yd), to tie around the dog's neck
- Polyester fibrefill
- Sand or small pebbles
- Sandwich bags
- Matching thread
- Basic sewing kit

## FABRICS USED

- Star, Dark Blue denim. From The Denim Company, [www.thedenimcompany.co.uk](http://www.thedenimcompany.co.uk)

## NOTES

- Download the templates from [www.simplysewingmag.com/downloads](http://www.simplysewingmag.com/downloads)
- Use a 5mm (1/4in) seam allowance.

## CUTTING OUT

**Step one** Download and cut out the templates.  
**Step two** When the templates specify to cut one pair, draw around the template then flip it over so the other is cut as a mirror image of the first. Cut the following pieces from the fabric: **01**  
 Main body – cut one pair.  
 Side head – cut one pair.  
 Back head – cut one.  
 Underbody – cut one.  
 Front leg – cut one pair.  
 Back leg – cut one pair.  
 Foot – cut four.  
 Ear – cut four.

## ATTACHING THE LEGS

**Step one** Pin the front leg pieces right sides (RS) together to the front of the main body, with the A marks and B marks matched. Place on the correct side so the curved edges match.  
**Step two** Stitch a foot piece to the bottom edge of the front legs and main body RS together. **02**  
**Step three** Repeat to stitch the back leg pieces to the main body, matching C and D marks.  
**Step four** Stitch a foot piece to the bottom edge of the back legs and main body RS together. **03**

## ASSEMBLING THE BODY

**Step one** Pin one side of the underbody RS together to the main body and legs, matching up the front and back, then stitch into place.

**Step two** Pin the other side of the underbody to the main body and legs then stitch into place.  
**Step three** Sew the tail sections of the main body piece RS together, leaving the back open.  
**Step four** Turn the dog RS out and press.  
**Step five** Fill the sandwich bags with sand so they fit snugly in the legs then tie them up tightly and put to one side for now. **04**

## MAKING THE HEAD

**Step one** Sew the bottom straight edge of one ear RS together to the position marked on one side head. Repeat with another ear.  
**Step two** Sew the other ear pieces RS together to the positions marked on the back head piece.  
**Step three** Pin the back head piece RS together to one side piece, matching up the ears, then stitch together from the back to the front. **05**  
**Step four** Repeat to sew the other side head piece to the back head pieces, matching seams.

## ASSEMBLING THE DOG

**Step one** Pin the head to the body with RS together and stitch into place.  
**Step two** Stitch the dart in the back head closed, continuing a little down the back of the body, then turn RS out through the opening.  
**Step three** Slip the sand bags into each leg then stuff the dog very firmly.  
**Step four** Slip stitch the gap securely closed, and then tie the ribbon on to finish. **06**

Simply  
**Sewing**  
FRESH IDEAS WITH FABRIC

# WORKSHOP

## MITRED BORDERS

*Every issue, our sewists present classic projects and techniques.*



# LEARN THE TECHNIQUE

When you've spent a lot of hours making a project, it's the finishing touches that are really worth the time and effort, and mitred borders are a great example of this. These give a neat finish and reduce the bulk of the fabric so it looks smoother and more professional. There are several methods of working a mitred border depending on what it's used on and the effect you would like to create.

## MITRED BORDER WITH INSERT

This method is ideal for adding a wide border to an item that needs to look attractive on both sides, such as a napkin. The backing fabric is mitred, and then the front fabric is slipped underneath and stitched into place.

**Step one** Turn the edges of the main fabric piece under by 1cm ( $\frac{3}{8}$ in) to the wrong side (WS) all the way around then turn the edges over by 3cm ( $1\frac{1}{4}$ in) to the WS and press.

**Step two** Working on one corner, open just the 3cm ( $1\frac{1}{4}$ in) crease.

**Step three** Measure and mark 6cm ( $2\frac{1}{2}$ in) up and along from the corner on both sides. Draw a line through the pressed corner to join the marks.

**Step four** Fold the corner in half diagonally so it is right sides (RS) together and match up the marks on each side, then pin and stitch together.

**Step five** Trim the corner fabric off outside the stitched line then turn RS out to form a neat point.

**Step six** Repeat this with the other three corners.

**Step seven** Slip the contrast fabric under the mitred border so the fabrics are WS together and then topstitch into place close to the edge. **01**

## SEPARATE MITRED BORDER

This border is made as a separate piece to the main fabric you're edging so can be made from a contrast colour and to any width. It's attached to the main fabric once complete and lays on top of it. It gives a neat outer and inner edge and works well for table runners and tablecloths.

**Step one** Decide how wide you want your finished border to be then cut the border fabric as follows:

**Long edges:** two strips to the finished width of the border + 2cm ( $\frac{3}{4}$ in) x the length of your main fabric.

**Short edges:** two strips to the finished width of the border + 2cm ( $\frac{3}{4}$ in) x the width of your main fabric.

**Step two** Turn one long edge on each border strip under by 1cm ( $\frac{3}{8}$ in) to the WS.

**Step three** Place one long edge border piece RS together with one short edge border piece, making sure the folded edge and unfolded edge line up exactly. The folded-under edge needs to be positioned at the top.

**Step four** Measure along the folded edge from the top left corner to the same width as your pressed-under border and mark with a pin.

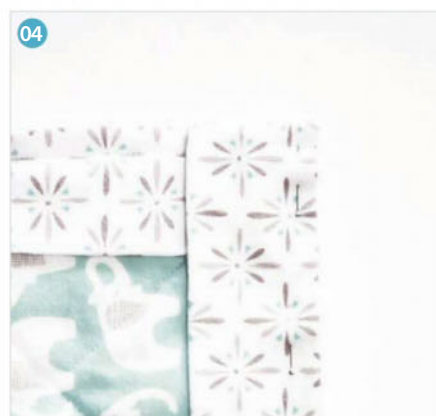
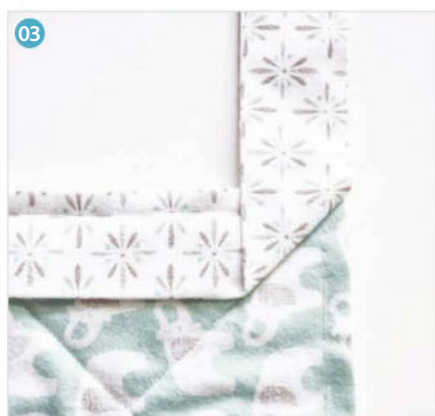
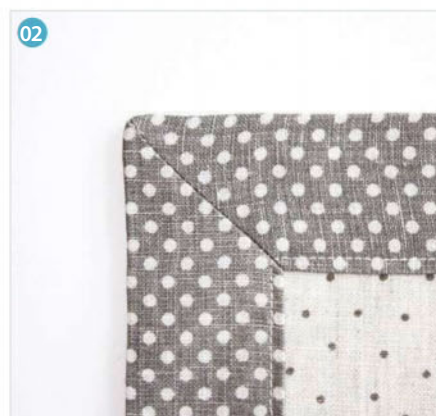
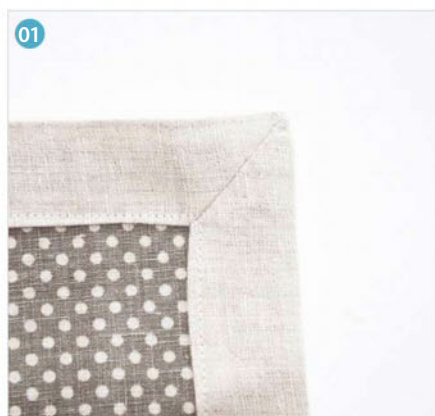

**Step five** Draw a diagonal line from the bottom left corner to this pin mark.

**Step six** Stitch the two border strips together along this line then trim the seam and press open.

**Step seven** Repeat this process to pin, mark, stitch and trim the other three corners in the same way to complete the border.

**Step eight** Lay the main fabric WS up with the assembled border RS down on top, matching raw edges, and pin then stitch together.

**Step nine** Turn RS out so the border is now laying neatly on top of the fabric.

**Step ten** Press then topstitch the inner edge of the border into place. **02**

## MITRED QUILT BINDING

This method is often used for binding the edge of a quilt as it's more hard-wearing because the border is made from two layers of folded fabric with neat mitred corners.

**Step one** Cut the binding fabric into 10cm wide strips to give a finished border of 1.5cm ( $\frac{3}{16}$ in) then join the strips RS together so they fit around the main fabric with a little extra for joining.

**Step two** Fold the joined strip in half lengthways with WS together and press.

**Step three** Starting in the centre of one side, pin the folded strip RS together with the edge of the quilt, matching raw edges but leaving a tail of the strip extending beyond this centre point for joining later.

**Step four** Stitch the folded strip to the quilt but stop stitching when you reach 1cm ( $\frac{3}{8}$ in) from the end and backstitch to secure.

**Step five** Take your quilt out from under your machine and fold the strip upwards so it makes a 45° angle at the corner then press. **03**

**Step six** Hold this in place then fold the strip back down so the top folded edge is now level with top edge. Press then pin into place. The rest of the strip should be RS together down the next side to be sewn with raw edges matching. **04**

**Step seven** Starting at the top, stitch all the way down the side until you reach 1cm ( $\frac{3}{8}$ in) from the end. Repeat to fold the corner in the same way as the last time.

**Step eight** Fold and stitch each corner in the same way then join and trim the ends.

**Step nine** Fold the binding over to the backing fabric side and make diagonal folds to mitre the corners on the back.

**Step ten** Stitch the binding into place by hand or machine and slip stitch the mitred corners together.

# MAKE A QUILTED COASTER

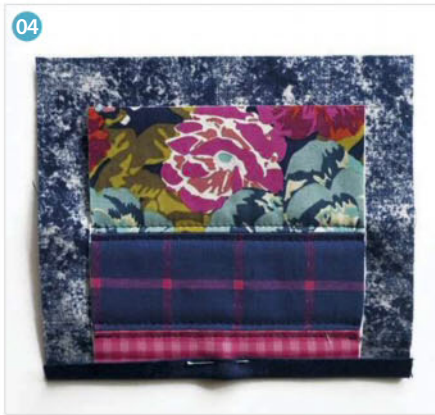
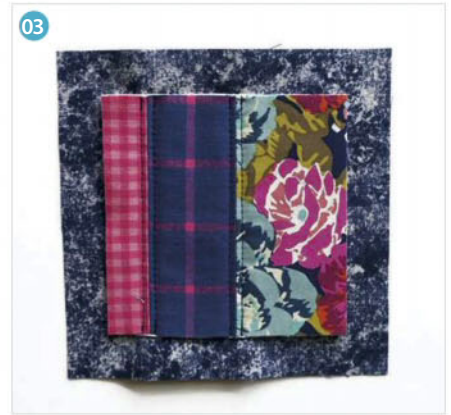

## YOU WILL NEED

- Cotton fabric A: 3x11cm (1¼x4¾in)
- Cotton fabric B: 5x11cm (2x4¾in)
- Cotton fabric C: 7x11cm (2¾x4¾in)
- Cotton fabric D: 20x20cm (7¾x7¾in)
- Wadding: 20x20cm (7¾x7¾in)
- Matching thread
- Basic sewing kit

## NOTE

- Use a 1cm (¾in) seam allowance.

This method of mitring brings the backing over to the front then uses this to bind the edges, and the corners are mitred as you go. It's ideal for a project that needs to lay flat without any extra bulk at the corners, such as a coaster or tablemat.

We've used three different widths of fabric strip in our coasters, and you can alter the widths of these for a slightly different look. The width of the joined strips should add up to 11cm (4¾in) and you need to add 1cm (¾in) seam allowance to one side of each of the outer strips and 1cm (¾in) seam allowance to each side of the centre strip.

## JOINING THE STRIPS

**Step one** Place the fabric A strip and the fabric B strip right sides (RS) facing and stitch together down the length.

**Step two** Press the seam open.

**Step three** Place the fabric C strip and the raw long edge of the fabric B strip RS facing and stitch together down the length.

**Step four** Press the seam open. <sup>01</sup>

## QUILTING THE COASTER

**Step one** Place fabric D RS down with the wadding on top then the pieced strips centrally on top of the

wadding. Pin and then tack together.

**Step two** Topstitch down each side of the seams, just 3mm (¼in) away from them. <sup>02</sup>

**Step three** Trim the wadding level with the pieced top, but don't cut through the backing fabric.

**Step four** Trim the backing fabric to 2cm (¾in) outside the edge of the pieced fabrics and wadding all the way around. <sup>03</sup>

## MITRING THE CORNERS

**Step one** Fold the edge of the backing fabric on one side over by 1cm (¾in) to the front of the coaster and press.

**Step two** Fold it over again by 1cm (¾in) so it lies on top of the pieced square. <sup>04</sup>

**Step three** Fold the pressed corner at a diagonal so it lines up with the unpressed adjacent side. <sup>05</sup>

**Step four** Fold the adjacent unpressed side over by 1cm (¾in) then 1cm (¾in) again on top of the pieced square to form a neat mitred corner.

**Step five** Press and pin the corner into place. <sup>06</sup>

**Step six** Repeat this on each side and corner, pressing and pinning into place as you go.

**Step seven** Topstitch the binding into place all the way around close to the folded edge, pivoting your needle at the corners.

**20% OFF!**  
YOUR FIRST ORDER  
WITH CODE  
**SS2018**



**GUTERMANN THREAD PACK INCLUDING SEAM RIPPER**

Essential starter kit with 11 sewing threads in basic shades. Kit includes a measuring aid and Gutermann seam ripper.

£19.99



**MOUSE FAMILY KIT**

Make your own mouse family with this cute and friendly kit

£25.99



**PENGUIN KIT**

Available in a range of colours. Make this cute penguin this winter.

£19.99



**LIBERTY EMILY FABRIC**

We love Liberty. This would look fabulous on the inside of a blazer cuff.

£7.99



**TAILORING & ALTERATIONS**

J Francois Campbell makes alterations easy with this informative book.

£14.99



**FISKARS SOFT GRIP SHEARS**

Make cutting as easy as 1, 2, 3, snip with these soft grip shears from Fiskars.

£22.99



**LIBERTY PINK FABRIC**

This delicate design is part of Liberty's new English Garden collection.

£7.99



**POLAR BEAR KIT**

A great kit for a toy maker, including every thing you need to make this little fella.

£18.99



**FLORAL FAT QUARTERS**

Pick up this Sew Easy set of fat quarters, in delicate floral and stripe designs.

£14.99



**BOTANICAL FAT QUARTER**

Botanical Plum Print Fat Quarter from Tilda's Cottage Collection Range.

£4.99



**FABRIC BUTTONS**

Add a sweet touch to your next garment with these Tilda buttons.

£4.99



**HOME SEWN HOME BOOK**

Sally Walton tells us how to make a variety of practical handmade items.

£14.99



**SEWIST NECKLACE**

Cult brand Tatty Devine have designed this 'Sewist' necklace..

£30.00



**GUTERMANN THREAD PACK**

This beautiful 7 piece pack of threads is a great addition to your spool rack.

£8.99



**ROSE GOLD PLATED SHEARS**

Make swift work of your projects with rose gold coloured dressmaking shears.

£16.99



**HEARTWOOD PARSLEY**

This cornflower blue fabric is perfect for getting home decor ready for Spring.

£5.49



**BEE SEWING BOX**

Buzz off the winter blues with this sweet sewing box.

£27.99

**... & MUCH, MUCH MORE AVAILABLE ONLINE!**

f SewingQuarter @SewingQuarter @SewingQuarter SewingQuarter

\* No minimum spend. Offer is available online only and can be redeemed by using voucher code SS2018 at the checkout on www.SewingQuarter.com. Offer expires 31st March 2018. Voucher code is not redeemable on TV promoted product within the 24hrs it is on air. One use per customer. Excludes electrical items. For full terms and conditions, please visit the Sewing Quarter website.

From the makers of

Simply Sewing

LOVE Quilting

TODAY'S QUILTER  
Create beautiful quilts for your home

Mollie MAKES  
BRAND & CREATIVITY LIVE

# Sewing QUARTER

WATCH IT • LOVE IT • SEW IT

The UK's first television channel dedicated to sewing, live on **Freeview 78** every day, has an online store that's filled to the brim with sewing products. New to Sewing Quarter? Use discount code **SS2018** to get **20%** off your first order.



**20% OFF!**  
YOUR FIRST ORDER  
WITH CODE  
**SS2018**



SEE OUR FULL PRODUCT RANGE AT  
[www.SewingQuarter.com](http://www.SewingQuarter.com)





# DOMESTIC BLISS

Pretty up your utility room with  
coordinating laundry-day makes in  
pastel linens by **Torie Jayne**.

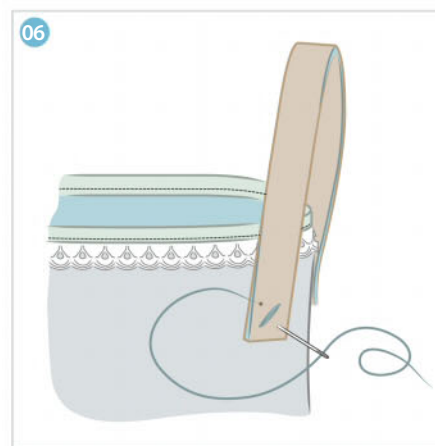
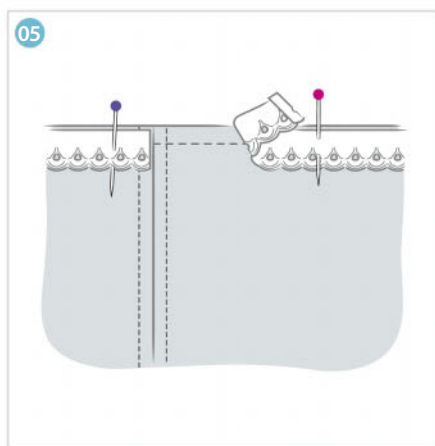
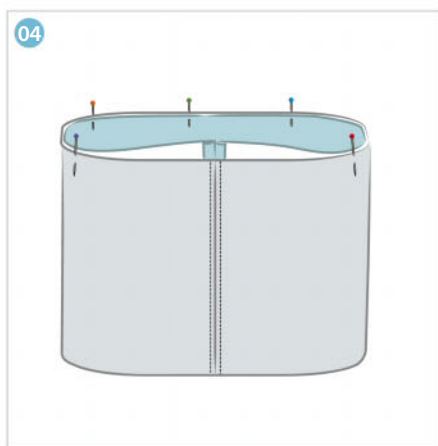
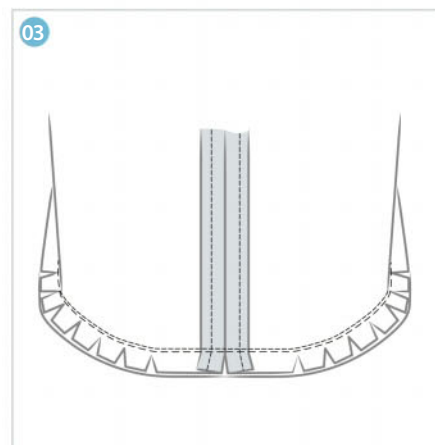
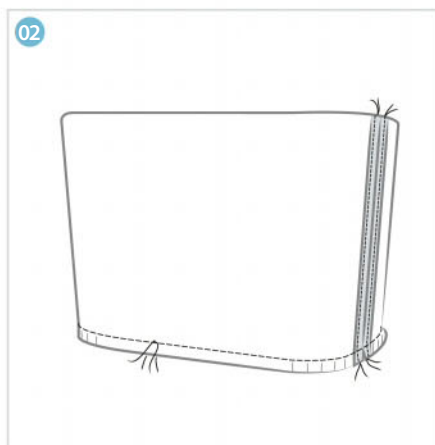
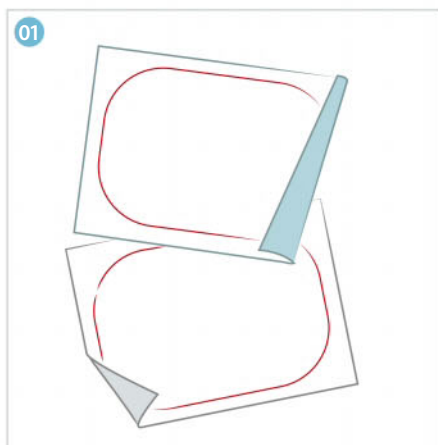

## LAUNDRY BASKET

### YOU WILL NEED

- Main fabric: 70x112cm (28x44in)
- Lining fabric: 70x112cm (28x44in)
- Stiff interfacing: 37.5x26cm (14¾x10¼in)
- Iron-on interfacing: 110x90cm (44x36in)
- Broderie anglaise trim with one finished edge: 1.1m (1¼yds)
- Bias binding tape: 12mm (½in) width x 1.1m (1¼yds)
- Bridle leather: 2cm (¾in) width x 67cm (26in)
- Pearlised acrylic paint and a small paintbrush
- Stranded cotton to match lining
- Matching sewing thread
- Basic sewing kit

### NOTES

- Download the template from [www.simplysewingmag.com/downloads](http://www.simplysewingmag.com/downloads)
- Use a 1cm (¾in) seam allowance unless otherwise stated.

Designer Torie Jayne says: "This laundry basket has a number of storage uses, from laundry to towels and bed linen. Linen gives it a rustic feel and looks great combined with the broderie anglaise trim. For the interior fabric I chose a textured cotton lining in a duck-egg blue and painted the leather handles to match."

### CUTTING OUT

**Step one** Cut the main fabric as follows:

Base: 37.5x26cm (14¾x10¼in).

Sides: 110x28cm (43¼x11in).

**Step two** Cut the lining fabric as follows:

Base: 37.5x26cm (14¾x10¼in).

Sides: 110x28cm (43¼x11in).

**Step three** Cut the iron-on interfacing:

Base: two pieces 37.5x26cm (14¾x10¼in).

Sides: two pieces 110x28cm (43¼x11in).

### PREPARING THE PIECES

**Step one** Paint the edges of the leather strip with pearlised paint and leave to dry.

**Step two** Download and cut out the template for the base.

**Step three** Using a water-soluble marker or a dressmaker's pencil, draw around the base template on the wrong side (WS) of the main fabric, lining fabric and stiff interfacing. **01**

**Step four** Repeat this to draw two base shapes on the iron-on interfacing and cut them out.

**Step five** Press one iron-on interfacing base to

the WS of the main fabric base. Press the other iron-on interfacing base piece to the WS of the lining fabric base.

**Step six** Press one iron-on interfacing side to the WS of the main fabric side. Press the other iron-on interfacing base piece to the WS of the lining fabric side.

### MAKING THE BASKET OUTER

**Step one** Fold the main fabric side piece in half widthways with right sides (RS) together and matching the raw edges of the short sides.

**Step two** Stitch together, starting at the top edge and finishing 1cm (¾in) from the bottom edge, backstitching at either end.

**Step three** Press the seam open then turn RS out and topstitch 5mm (¼in) either side of the seam line. This will hold the seam allowance in place and give a decorative finishing touch.

**Step four** Staystitch around the bottom of the bag all the way around slightly less than 1cm (¾in) from the lower edge.

**Step five** Snip up to this sewn line at regular intervals all the way around as this will help when stitching the bottom in place. **02**

**Step six** With RS together and raw edges even, pin the lower edge of the main fabric side piece all around the edge of the main fabric base, lining up the seam so that it is in the centre of one of the ends.

**Step seven** Stitch the base carefully into place

all around the edge. <sup>03</sup>

### ASSEMBLING THE BASKET

**Step one** Repeat this to assemble the lining side and base but don't topstitch either side of the seam this time.

**Step two** Lay the stiff interfacing base on the iron-on interfacing side of the lining base and hand-stitch it to the seam allowance in a few places to hold.

**Step three** Place the lining inside the outer so they are WS facing and the seams are lined up.

**Step four** Pin then stitch together 5mm ( $\frac{1}{4}$ in) from the top edge all the way around. <sup>04</sup>

### FINISHING THE TOP EDGE

**Step one** Starting at the seam, pin the broderie anglaise trim to the RS of the basket outer all around the top edge, matching the straight edge of the trim with the raw edge of the linen.

**Step two** When you get back to your starting point, turn under 5mm ( $\frac{1}{4}$ in) on the end and overlap the raw edge of the starting end.

**Step three** Stitch into place 5mm ( $\frac{1}{4}$ in) from the top edge. <sup>05</sup>

**Step four** Fold the bias binding around the top edge of the basket to encase all the raw edges, overlapping and folding under the short ends. Topstitch into place.

### ATTACHING THE HANDLES

**Step one** Cut the leather in half then mark four holes at each end of the lengths to sew the handles on with.

**Step two** Clip the end of the handles to the basket, positioned 6cm ( $2\frac{1}{4}$ in) from the top, and 7cm ( $2\frac{3}{4}$ in) apart.

**Step three** Stitch the handles to opposite sides of the basket with all six strands of the stranded cotton. Stitch through the hole several times so the handles are held securely in place. <sup>06</sup>

## PEG BASKET

This is made in much the same way as the laundry basket, but using the two templates to cut one base and two side pieces.

**Step one** Download the peg basket templates, and using the base template cut one each from main fabric, lining fabric and stiff interfacing. Cut two from the iron-on interfacing.

**Step two** From the side template cut two each from the main fabric and lining fabric. Cut four from the iron-on interfacing.

**Step three** Press the interfacing to the WS of the main fabric and lining fabric side pieces.

**Step four** Stitch the main fabric side pieces RS together then attach the base.

**Step five** Assemble the peg basket in the same way as for the laundry basket

**Step six** The peg basket has just one handle, made from a 30cm (12in) length of 1.5cm ( $\frac{5}{8}$ in) wide bridle leather, attached 3.5cm ( $1\frac{3}{8}$ in) from the top, overlapping the side seams.



Stylish Home Sewing by Torie Jayne, published by CICO Books, £12.99. Photographs by Susie Bell © CICO Books 2015

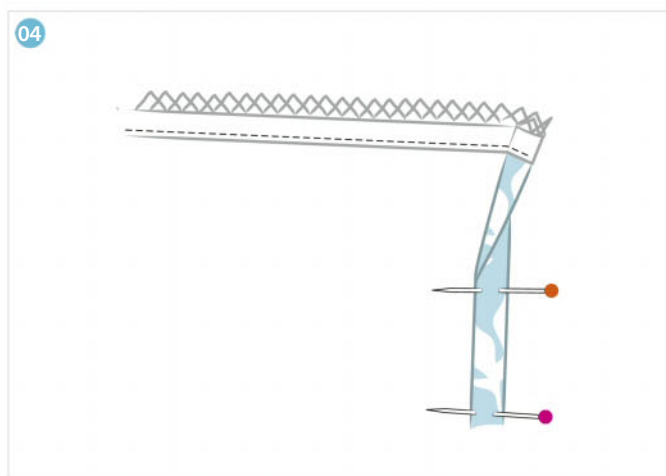
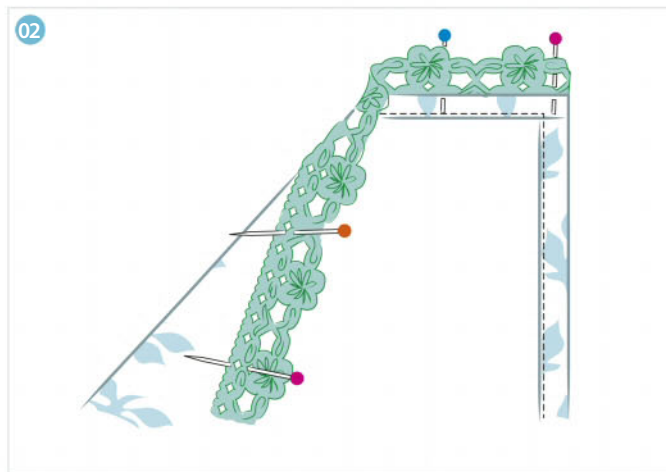

## TEA TOWELS

### YOU WILL NEED

#### For the crochet-trimmed tea towel

- 100% cotton or linen fabric: 46x54cm (18x21½in)
- Crochet trim: 84cm (33in)
- Fray-stop liquid
- Eyelet kit
- Matching thread
- Basic sewing kit

#### For the bound-edge tea towel

- 100% cotton or linen fabric: 46x50cm (18x20in)
- Crochet-edge bias binding: 92cm (36in)
- Eyelet kit
- Matching thread
- Basic sewing kit

Torie says: "With this easy sewing project, you'll wonder why you have never run up tea towels to match your kitchen before. Adding a useful eyelet at one of the top corners allows you to hang the tea towel from a hook."

#### MAKING THE CROCHET-TRIMMED TEA TOWEL

**Step one** Press the long edges of the fabric under by 1cm (¾in) then 1cm (¾in) again to the wrong side (WS).

**Step two** Pin and then topstitch this double hem into place.

**Step three** Repeat this for the two short sides of the fabric. **01**

**Step four** Cut the crochet trim in half to make two equal lengths.

**Step five** Apply fray-stop liquid to the cut ends of the both lengths of crochet trim then leave them to dry.

**Step six** Pin one length of the trim to the right side of the tea towel along one short edge then topstitch into place. **02**

**Step seven** Repeat this to pin and topstitch the other length of trim to the other short side of the tea towel.

**Step eight** Insert an eyelet to the top corner of the tea towel for hanging, following the manufacturer's instructions.

#### MAKING THE BOUND EDGE TEA TOWEL

**Step one** Cut the crochet-edge bias binding in half to make two equal lengths.

**Step two** Fold one length around one short end of the fabric so that the raw edge of the fabric goes right inside to the fold.

**Step three** Topstitch the binding into place then cut the edge of the trim to meet the edges of the fabric if necessary.

**Step four** Repeat this on the other short end of the fabric using the other length of crochet-edge bias binding. **03**

**Step five** Turn each long edge under by 1cm (¾in) to the WS then 1cm (¾in) again to form a double hem.

**Step six** Pin and then topstitch these double hems into place. **04**

**Step seven** Insert an eyelet to the top corner of the tea towel for hanging, following the manufacturer's instructions.



This laundry set is one of over 35 projects to sew for your home from *Stylish Home Sewing* by Torie Jayne, published by CICO Books. £12.99, [www.cicobooks.co.uk](http://www.cicobooks.co.uk)

FREE  
TRIAL FOR  
YOU!

# DOWNLOAD YOUR ISSUE OF SIMPLY SEWING NOW!

You can buy a digital edition of *Simply Sewing*, ready to read whenever you want. Single issues and subscriptions are available and every issue you purchase is stored in your magazine library permanently. Once your magazine has downloaded, an internet connection is not required so you can take your magazine with you, wherever you go.

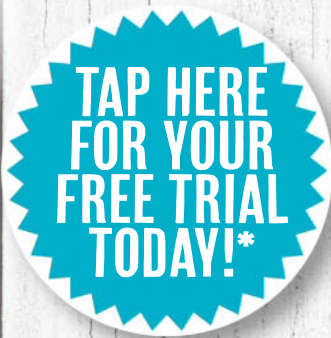

To buy your digital copy of *Simply Sewing*, visit  
[www.simplysewingmag.com/digital](http://www.simplysewingmag.com/digital)

On Android or PC/Mac? Find us on  
[www.zinio.com/simplysewing](http://www.zinio.com/simplysewing)



iPad is a trademark of Apple Inc., registered in the U.S. and other countries. App Store is a service mark of Apple Inc. NOOK is a registered trademark of Barnes & Noble, Inc. NOOK Tablet is a trademark of Barnes & Noble, Inc.

\*Free trial not available on Zinio

# LEADING LADY

Sew a budding dancer their own  
tutu-cute ballerina doll in twirly  
tulle with **Jo Carter's** tutorial.





**BUY THIS KIT!**

*Sewing*  
**QUARTER**

See this demonstrated  
live on air on  
6th January 2018 \*  
Live on  
**Freeview 78**

\* Visit page 15 for special offers and T&Cs



## YOU WILL NEED

- Fabric A: 50x50cm (20x20in), for main body
- Fabric B: pink, 35x35cm (14x14in), for leotard and shoes
- Felt: 20x28cm (8x11in), for hair
- Tulle: 28x60cm (11x24in)
- Stranded cotton: black and pink
- Polyester toy filling
- Matching thread
- Basic sewing kit

## FABRICS USED

- **Fabric A:** Kona Cotton Solids, Sand. Robert Kaufman.
- **Fabric B:** Spot On, Cheeky Pink. Makower.

## FINISHED SIZE

- Approx: 40cm (16in) tall.

## NOTES

- Download the templates from [www.simplysewingmag.com/downloads](http://www.simplysewingmag.com/downloads)
- Use a 5mm (1/4in) seam allowance.
- As the legs, arms and ears are sewn directly into seams, sew over the joins twice so they are well-secured to reduce the likelihood of them being pulled out.

## CUTTING OUT

**Step one** Download and cut out all the template pieces. The templates include seam allowances where necessary and the arrows indicate the print direction for marking and cutting out. The notches are used to match pieces when stitching together, so mark these too.

**Step two** When the pattern specifies to cut two or more of a template, after marking out half of the pieces required, the template needs to be turned over to mark out the remaining half so that the pieces are cut as mirror images.

**Step three** Using a water erasable pen or pencil draw out the pattern pieces onto the wrong side (WS) of the fabric and cut out the following:

### From Fabric A:

- Face – cut 1.
- Ear – cut 4.
- Back head – cut 1.
- Front body – cut 1.
- Arm – cut 4.
- Front leg – cut 2.
- Back leg – cut 2.

### From Fabric B:

- Front leotard – cut 2.
- Back body/leotard – cut 2.
- Lower body/leotard – cut 1.
- Front shoe – cut 2.
- Back shoe – cut 2.

### From tulle:

Cut two strips each measuring 14x60cm (5½x24in).

### From felt:

- Hair bun – cut 1.
- Front hair – cut 1.
- Back hair – cut 2.

## ATTACHING THE HAIR

**Step one** With right sides (RS) facing up, position the front hair over the top of the face piece and stitch into place around the edges, taking the stitch lines up and down to 'draw' the sweep of the hair.

**Step two** Fix the back hair pieces to the back head in the same way. <sup>01</sup>

## ATTACHING THE EARS

**Step one** Place two ear pieces RS facing and sew together, leaving the straight edge open.

**Step two** Clip V-shaped notches in the seam allowance around the curve and turn RS out. Tack the open edge closed.

**Step three** Repeat to make the other ear. <sup>02</sup>

**Step four** With RS together, close each of the three darts in the face piece and then tack the ears on either side of the face where marked. <sup>03</sup>

## MAKING THE UPPER BODY

**Step one** Place the two front leotard pieces RS



facing and sew together along the top V-shaped section.

**Step two** Clip the seam allowance at the internal corner, turn RS out and press.

**Step three** With RS facing up, position the front leotard on top of the front body and tack together from shoulder to shoulder. **04**

**Step four** Sew the back body/leotard pieces to the front body/leotard pieces with RS together at the shoulders. **05**

**Step five** Sew the back head to the upper body/leotard section with RS together around the 'neck' section. **06**

### MAKING THE ARMS

**Step one** Place two mirror-image arm pieces RS facing and sew together around the sides.

**Step two** Clip V-shaped notches in the seam allowance around the curves and clip into the internal corners above and below the thumb.

**Step three** Turn RS out, stuff and tack closed.

**Step four** Repeat this to make the other arm. **07**

### ATTACHING THE ARMS AND FACE

**Step one** With RS together, fit an arm at the top of one side of the upper body section where marked and sew the side of the body together, fixing the arm in place.

**Step two** Repeat for the other arm and side. **08**

**Step three** Sew the face around the back head RS together, lining up the markers. **09**

### MAKING THE TUTU

**Step one** Fold the strips of tulle in half lengthways and press with a cool iron.

**Step two** Place one on top of the other with the folded edges together. Using a wide tacking stitch, sew together along the folded edge just inside the seam allowance.

**Step three** Knot the threads at one end so they don't work loose and pull on the bobbin thread at the opposite end to gather. Gather the top of the tutu evenly until it measures 20cm (8in). **10**

### ATTACHING THE TUTU

**Step one** Tack the gathered edge of the tutu RS together to the bottom of the upper body/leotard, adjusting it to fit. **11**

**Step two** Sew the lower body/leotard to the upper body/leotard with RS together, sandwiching the tutu in place.

**Step three** Lightly press the seam upwards towards the head and then topstitch along the bottom of the upper body/leotard close to the seam to hold the seam allowance up and therefore the tutu in a downward position. **12**

### JOINING THE BACK SEAM

**Step one** With RS facing sew the back of the lower body/leotard together. Start at the bottom and stitch upwards, finishing 1cm (3/8in) before the tutu seam.

**Step two** Bring the front and back of the lower

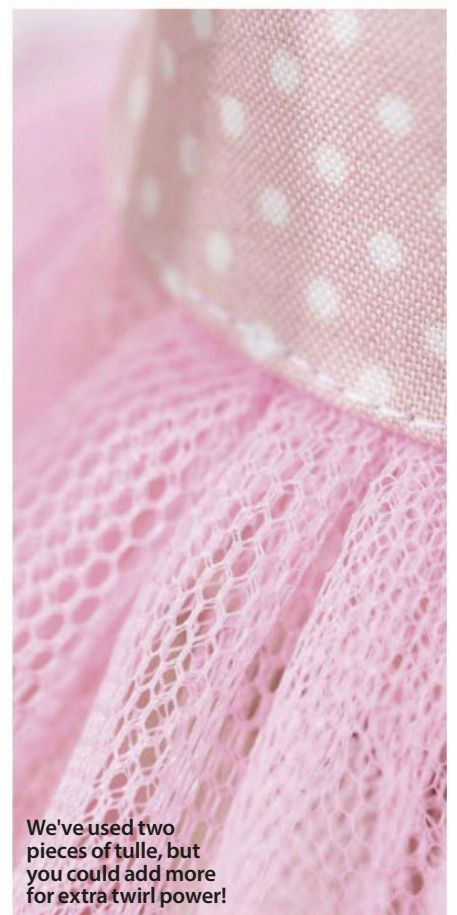

We've used two pieces of tulle, but you could add more for extra twirl power!



body/leotard together. Pin then sew together and leave the leg openings on either side. **13**

## MAKING THE LEGS

**Step one** With RS together, sew a back shoe to the bottom of a back leg and a front shoe to the bottom of a front leg.

**Step two** Place the legs RS facing and sew together, leaving the top open.

**Step three** Clip V-shaped notches in the seam allowance around the curve and turn RS out.

**Step four** Stuff and then tack the end closed.

**Step five** Repeat to make the other leg. **14**

## ATTACHING THE LEGS

**Step one** With the leg inside the body, fit the top into one of the openings in the lower body/leotard so that the longer side of the leg is at the outer folded side of the lower body and the bottom shoe faces the back of the body.

**Step two** Pin together and then sew the opening closed to fix the leg in place.

**Step three** Repeat for the other leg. **15**

## FINISHING THE HEAD

**Step one** With RS facing, sew the back head together, leaving an opening in the back of the body for stuffing. Turn RS out and stuff.

**Step two** Work a running stitch around the hair bun and pull on the thread to gather the bun into a cup shape.

**Step three** Add stuffing into the centre and draw the bun up fully, folding the seam allowance to the inside, and secure the thread.

**Step four** Sew the bun to the top of the back head in a circle so that it is firmly fixed and then go around a second time for extra security. Secure the thread, take the needle through the bun and out then trim off the excess thread. **16**

## FINISHING OFF

**Step one** Using pink stranded cotton, backstitch the 'ribbon fastenings' on each front leg. **17**

**Step two** Draw facial features onto the face using a water erasable pen.

**Step three** Backstitch the cheeks using pink stranded cotton.

**Step four** Work the mouth and eyelashes in backstitch and the eyes in satin stitch using black stranded cotton. **18**

**Step five** Adjust any filling that has become disturbed and then close up the back using ladder stitch or similar to finish.

Up the cute-factor by swapping the hand-stitching for a real ribbon bow.



See Jo Carter sewing her soft toys live on air on Sewing Quarter on Freeview channel 78, at [www.sewingquarter.com](http://www.sewingquarter.com) or [www.youtube.com/sewingquarter](http://www.youtube.com/sewingquarter)

# POCKETFUL OF RAINBOWS

Raid your wardrobe  
(and your fabric stash)  
for this girl's pocket-  
detail jumper dress  
by Jennie Jones.



# TRANSFORM IT!



## YOU WILL NEED

- Jumper: a UK size 8-10 is ideal for this dress
- Cotton fabric: 8x10cm (3/8x4in), for the pocket
- Sew or iron-on patch
- Matching thread
- Basic sewing kit

## NOTE

- Use a 1cm (3/8in) seam allowance.
- Choose a lightweight and tight fitting jumper.

## FABRIC USED

- Pocket fabric: Dot Black denim from The Denim Company. [www.thedenimcompany.co.uk](http://www.thedenimcompany.co.uk)

## CUTTING OUT

**Step one** Measure your child from shoulder to chest then add 2cm (3/4in) to this for the seam allowances. These are 1cm (3/8in) either side.

**Step two** Cut off the top of the jumper to use for the bodice of the dress. Put the bottom section to one side, this will become the skirt. **01**

**Step three** Take your child's shoulder to armpit and neck to shoulder measurements. Add 2cm (3/8in) seam allowances. Cut the top section to these measurements. **02**

**Step four** Cut the sleeves to the right length to fit your child, with a 1cm (3/8in) seam allowance at the top edge. **03**

**Step five** Measure around your child's arm and restitch the sleeve seams so they are the right circumference. It's easier to stitch the sleeve and then trim off the excess, particularly if you're using a striped jumper like ours as the pattern will match up better.

## INSERTING THE SLEEVES

**Step one** Open out the bodice. Tuck one sleeve in with right sides (RS) facing and pin. **04**

**Step two** Stitch the sleeve into place then stitch the side seam closed.

**Step three** Repeat this with the other sleeve and side seam on the other side of the dress.

## ASSEMBLING THE DRESS

**Step one** Measure the bottom section of the

jumper against the length you want the skirt to be and trim any extra from the top of this so you retain the original jumper hem.

**Step two** Work a row of long stitches or overlock across the top to gather the skirt section. **05**

**Step three** Pull up these stitches to gather so they fit the bottom of the bodice.

**Step four** Tuck the bodice inside the skirt with RS facing, matching up the side seams, and pin together all the way around.

**Step five** Stitch the bodice into place then turn RS out and press.

## ADDING A POCKET

**Step one** Fold the top short edge of the pocket fabric under by 1cm (3/8in) to the wrong side (WS) then 1cm (3/8in) again to make a double hem and press.

**Step two** Topstitch this top hem into place.

**Step three** Cut the bottom two corners into a slight curve to make a pocket shape if you prefer or just leave it square.

**Step four** Press or sew the patch to the centre of the pocket.

**Step five** Work a machine zigzag stitch around the raw edges of the pocket or turn them under a little to hem. **06**

**Step six** Pin then sew the pocket to the skirt part of the dress to finish.

# NEW YEAR, NEW STASH

Bring a breath of fresh fabric flair to your stash this new year!



## 1 RIBBON AND THREAD

The only way to check out our 2018 range is to head over and visit our website. Specialising in fun and on trend... haberdashery and fabrics. We promise you'll find something you totally need and love.

[ribbonandthread.co.uk](http://ribbonandthread.co.uk)

## 2 SEWBOX

On-line stockists of a huge range of beautiful Liberty fabrics. Liberty Tana Lawns, Needlecord, Jersey, Lantana, Quilting cottons and Liberty fabric packs plus 'indie' dressmaking patterns. For amazing prices visit:

[sewbox.co.uk](http://sewbox.co.uk)

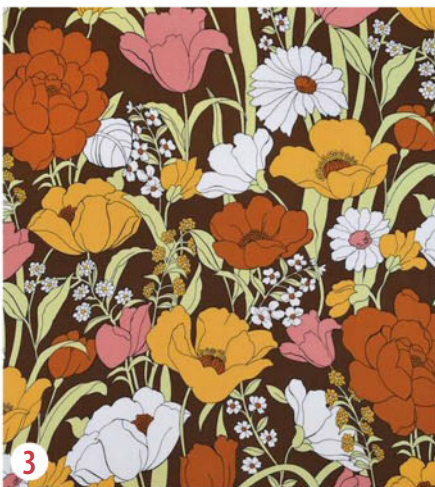

## 3 TRURO FABRICS

Trurofabrics.com offers a friendly, high quality service to every customer with an added personal touch from our team of experienced staff. 70's floral viscose crepe fabric 150cm wide is £12.99 per metre.

[trurofabrics.com](http://trurofabrics.com)

## 4 OAKAPPLE HABERDASHERY

Oakapple Haberdashery – contemporary fabric and quirky bits and bobs. January Sale! 40% off ALL fabrics from 1st to 31st January 2018. Use code Happysale40 at the checkout.

Find us online at:

[oakapplehaberdashery.co.uk](http://oakapplehaberdashery.co.uk)

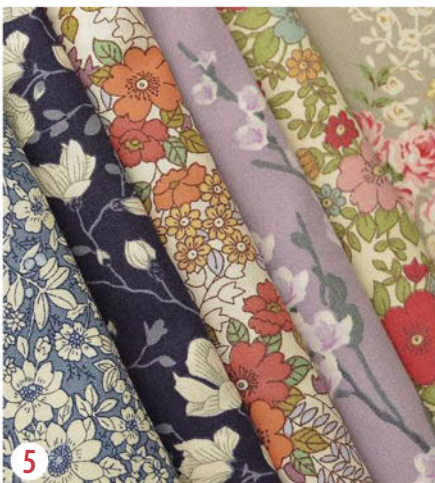

## 5 CROFT MILL

We are a family firm based in Lancashire and have been selling fabrics by mail order for over 40 years. We have hundreds of fabrics of all qualities to suit any project. Buy online or order your free catalogue.

[croftmill.co.uk](http://croftmill.co.uk)

## 6 TEMPTATIONS CRAFT BOUTIQUE

Cotton Poplin "Poppies" £5.70 per metre. Floral fabrics galore for dressmaking and patchwork. Haberdashery and patterns. Agents for Brother Sewing Machines. Visit our shop on the edge of the Yorkshire Dales or buy online.

[temptationsbentham.co.uk](http://temptationsbentham.co.uk)

# STASH SHOPPING

Fill up your stash with fabric, patterns and more from these fabulous shops!

## EAST MIDLANDS



### LEICESTERSHIRE CRAFT CENTRE

Workshops and courses for adults and children of all levels, craft supplies, patterns and fabric available online and in store.

[leicestershirecraftcentre.co.uk](http://leicestershirecraftcentre.co.uk)

## LONDON



### REALLY MARIA

An Extensive range of fabrics, wool, haberdashery, craft kits and workshops. New to London.

0203 5810909

[reallymaria.com](http://reallymaria.com)

## NORTH



### HAPPY HARE

An independent sewing store in Chapeltown, Sheffield, stocking a range of fabrics, including Michael Miller, Riley Blake and Tula Pink.

[handmadehappyhare.com](http://handmadehappyhare.com)

## SCOTLAND



### ROMY'S SEWING ROOMS

Bright, friendly shop for all sewers, selling patterns, fabric and notions. Sewing classes for all ages and abilities from an experienced dressmaker.

[facebook/Romyssewingrooms/](https://facebook.com/Romyssewingrooms/)

## NORTHERN IRELAND

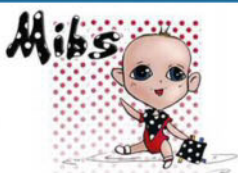

### MIBS FABRICS

Mibs fabrics specialise in all things stretchy. A whole host of other fabrics and a great range of haberdashery too. 10% off your first order with the discount code SIMPLY10.

07961 572060

[mibsfabrics.co.uk](http://mibsfabrics.co.uk)

## SCOTLAND

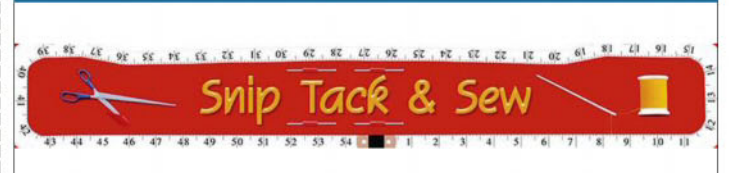

### SNIP TACK & SEW

We offer a bespoke service for all types of soft furnishing making. Fabrics, poles, roller, Duette, wood and aluminium venetian blinds to order.

Snip Tack & Sew, 7 Hill Street, Crieff, PH7 3BU

01764 650055

[sniptacksew.co.uk](http://sniptacksew.co.uk)

## SOUTH



### CHALK HILL BLUE FABRICS

Supplier of patchwork fabrics, threads, waddings and notions. Keep up with events on Facebook!

01903 230008

[FB/Chalk-Hill-Blue-Fabrics](https://facebook.com/Chalk-Hill-Blue-Fabrics)

## SOUTH



### SEW BUSY

Stockists of Makower, Robert Kaufman, Clothworks and Windham, ribbons, haberdashery, sewing goods and classes.

[sew-busy.co.uk](http://sew-busy.co.uk)

## SOUTH

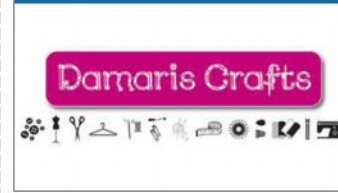

### DAMARIS CRAFTS - BEX

Yarns, fabrics & haberdashery. Wed, Fri & Sat 10-5pm, Thurs 1-8pm.

Sewing workshop 1st Saturday of the month. 07736353839

[damariscrafts.co.uk](http://damariscrafts.co.uk)

## SOUTH WEST



### INCHES FABRICS

Fabrics, Wools and Haberdashery. Buttons, Ribbons and Patterns.

Knitting and Sewing lessons.

39 Parsonage St, Dursley, Glos, GL11 4BP

[inchesfabrics.co.uk](http://inchesfabrics.co.uk)

## SOUTH WEST



### BECKFORD SILK

Silks & velvet. Natural, printed and dyed. Small quantities at wholesale prices.

01386 881507

[beckfordsilk.co.uk](http://beckfordsilk.co.uk)



For more great ideas, competitions, patterns and tutorials, go online!

[simplysewingmag.com](http://simplysewingmag.com)



To advertise here contact

Chris Gibson: 0117 300 8108

[chris.gibson@immediate.co.uk](mailto:chris.gibson@immediate.co.uk)

# Simply Sewing

FRESH IDEAS WITH FABRIC

## THE GUIDE

*You'll find essential information, useful stitches and key sewing techniques on these pages.*

### MARKING PEN

Transfer markings to your fabric, then wash them out when finished.



### MARKING PENCIL

Choose a colour that shows up on your fabric.

### TAPE MEASURE

A flexible fabric tape measure will take accurate measurements.

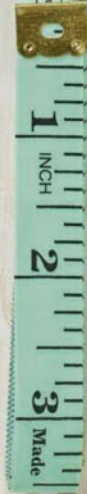

### FABRIC CLIPS

Use these instead of pins when sewing thicker fabrics.



### TAILOR'S CHALKS

Chalk temporarily marks fabric and can be easily brushed away.



### SEAM RIPPER

This sharp blade cuts through and unpicks stitches.



### PINS

Stainless steel pins with sharp points are best.



### THIMBLE

Wear to protect your fingers when handstitching.



### PINKING SHEARS

These cut a zigzag edge on fabric to neaten.



### SHEARS

Keep a pair of sharp shears just for cutting out your fabric.



### SMALL SCISSORS

Use for snipping threads and cutting notches.



# HOW TO MEASURE YOURSELF ACCURATELY

ALWAYS MEASURE YOURSELF BEFORE you choose a pattern size to cut out. The sizes do vary greatly from pattern to pattern, so it's always best to measure yourself accurately and then refer to the pattern's size chart to find your size. The chart will usually be printed on the pattern envelope or on the instructions inside.

Measure yourself in your underwear and preferably in the bra you'll be wearing underneath

your garment as this can alter the measurements slightly. Use a fabric tape measure as it'll curve around your body well for accuracy. You can measure on your own if you stand in front of a mirror, but, for best results, ask a friend to help so they can check the tape measure is sitting in the right places. Make sure the tape measure sits snugly around you but is not pulled tight.

Take the measurements shown in the diagram and note them down.

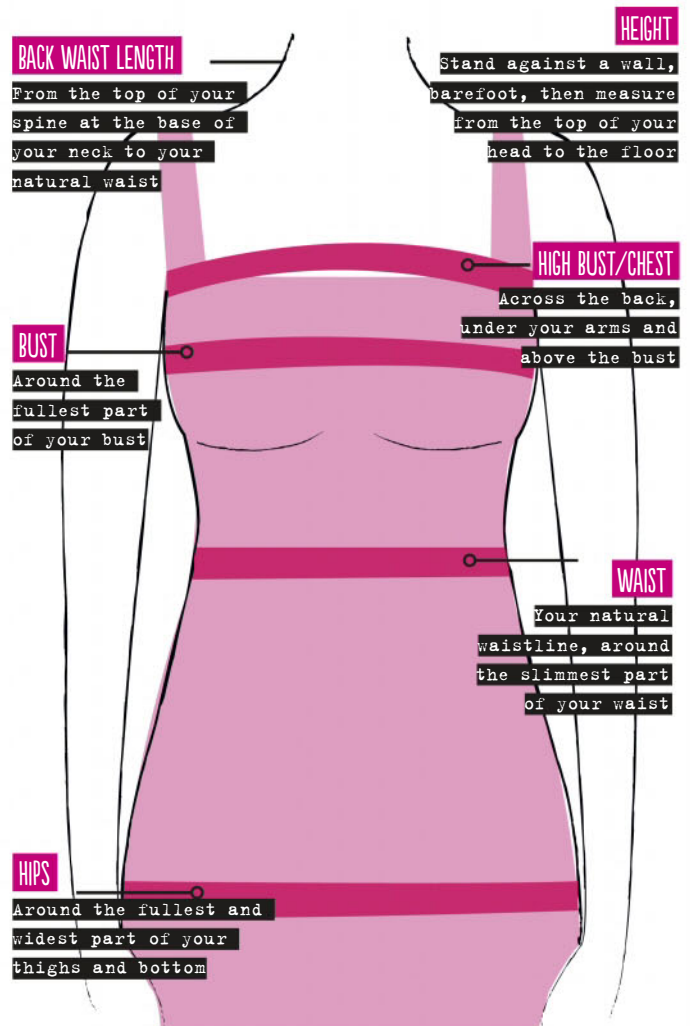

# HOW TO USE A PATTERN

Preparing your fabric and cutting out your sewing pattern accurately is just as important as the actual sewing. Wash your fabric before you begin as fabric can shrink and run. Once dry, press it well.

## PREPARING THE PATTERN

Patterns often come with several options of different finishes so you may have more pieces than you need. The instruction sheet will tell you which pieces to use. Roughly cut out all of the pieces outside the lines then press the pieces using a dry iron on a low heat to remove the folds and creases.

## CUTTING OUT THE PATTERN

Choose your size using your measurements and the size chart. Cut along the corresponding lines on your pattern. When you reach any fiddly curves, take care to cut along the correct size lines.

## CUTTING LAYOUTS

Choose the correct one for the width of fabric you're using, the

size you're cutting and the style of garment. Many patterns have more than one option (or view) and each one can have a different layout.

## CUTTING OUT

Lay your fabric flat and smooth it out. Fold or place the fabric as shown on the cutting layout. Lay the pattern pieces in the order and right side or wrong side up as shown. Check to make sure that the grainlines on the pattern are parallel with the selvages by measuring. Pin your pattern pieces carefully in place and cut around them through the fabric using a pair of dressmaker's shears.

## TRANSFERRING MARKINGS

The markings on the pattern pieces need to be transferred to the fabric. They're really important for matching up fabric pieces later and for positioning elements such as darts and pockets. You can mark these with chalk, fabric markers, snips on the fabric, or with small tacking stitches.

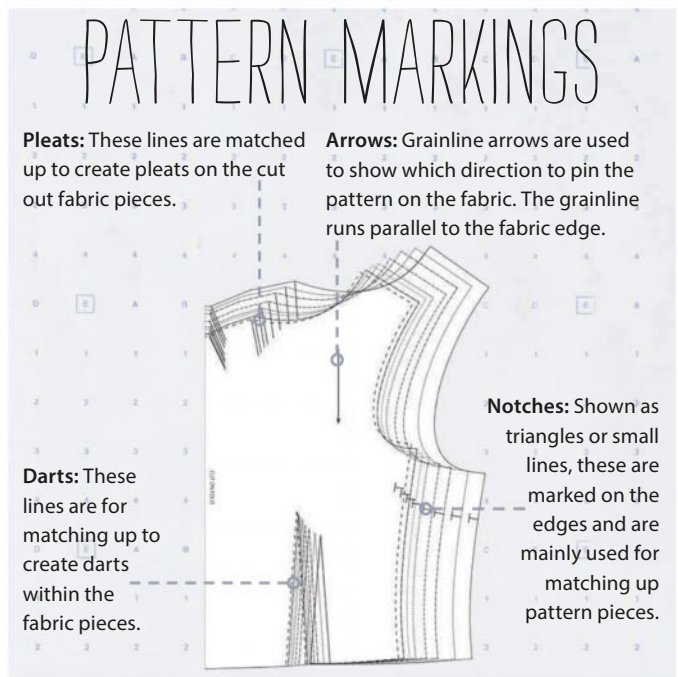

# CHOOSING AND BUYING FABRICS



IT'S IMPORTANT TO CHOOSE the correct fabric for your pattern. Most patterns give suggested fabric types that will work best with the style of garment. Use this to guide you as some patterns need more drape, body or structure than others.

Fabric can be made from natural fibres such as cotton, linen, wool and silk or synthetic fibres such as acetate, acrylic, nylon, polyester, rayon and viscose. All these fabric come in different weights, or thicknesses, which suit different garments.

Lightweight fabrics are ideal for lingerie, nightwear and summer clothing, and include cheesecloth, chiffon, crepe-de-chine, georgette, lawn, muslin, organdie, organza and voile.

Medium-weight fabrics, which work for dresses, shirts, trousers and childrenswear, include calico, cotton, crepe, dupion, linen, poplin and finer wool.

Heavy-weight fabrics are used for garments or projects needing more strength, like coats, jackets, winter wear and bags. Canvas, corduroy, denim, tweeds, velvet and wool are all in this category.

Some patterns require fabrics that are quite fluid and have a good drape to make them hang properly, such as a circle skirt or blouse. Synthetic or synthetic mix fabrics such as rayon, challis, chiffon or lightweight jersey have a better drape to them.

Stretch and knit fabrics such as jersey and lycra are virtually crease free and comfortable to wear. They

can be bought in a variety of thicknesses and qualities depending on their use but are ideal for sportswear and casual clothing.

Interfacing gives an extra layer of support to your fabric – for example, to stiffen facings and collars. Choose an interfacing that's slightly lighter than your main fabric, and if you're using a fusible (iron-on) option then always test it on a scrap of the fabric first as it can melt if the iron is too hot.

Interfacing is available in different weights and as an iron-on (fusible) or sew-in version. With fusible interfacing, press the shiny side to the wrong side of your fabric. Tack sew-in interfacing to the wrong side of the fabric pieces around the edges.

If you're buying fabric off a roll (or bolt) then you'll usually buy it by the metre. This is only the length of the fabric you're buying – the width depends on the width of the roll. Fabrics are sold in standard widths, which vary according to their purpose – for example, dressmaking or quilting fabric generally comes in standard widths of 112cm (44in) or 150cm (60in). Curtain or soft furnishing fabric is normally 137cm (54in) wide and is really useful for bags and aprons as it's thicker and stronger than dressmaking fabrics. The fabric requirements on the pattern instructions will tell you what length of fabric to buy, usually with two width choices. Some patterns, such as large circle skirts, can only be cut from the wider fabrics.

## FINISHING SEAMS

ONCE YOU HAVE FINISHED stitching your seam, it's best to press it open on the wrong side so it lies flat. Sometimes it's better to press it to one side to reduce bulk but the pattern instructions will tell you this.

Usually the seam allowances are left as they are as they help to strengthen the seam, but sometimes they cause too much bulk so they are trimmed to half their original width.

If your fabric has a tendency to fray you should neaten the raw edges after you have worked the seam. There are several ways of doing this. To machine-finish them, set your sewing machine to the zigzag stitch then stitch close to the raw edge all the way along. The zigzag must be small enough to stop the fabric from fraying but large enough to enclose the bulk of the fabric. Practise a few lengths and widths before you begin. Alternatively, you can trim the raw fabric edges with a pair of pinking shears. If you have an overlocker then you can stitch, cut and finish the seams all in one process.

## MACHINE NEEDLES

There are many different needle types and they vary by the shape of the point, eye and shaft thickness. Choose the correct one for smooth stitching.

### UNIVERSAL

A great multi-purpose needle which can be used for woven fabrics and has a slightly rounded point for stitching knit fabrics, too.

### BALL POINT

This needle has a more rounded point than the universal needle so you won't get snags, ladders or holes. Perfect for knit fabrics.

### JEANS

A strong needle, ideal for stitching several layers of fabric or tightly woven fabrics like denims.

### SHARPS

With a sharp point, these are for sewing very fine and delicate fabrics and neat buttonholes.

### LEATHER

This needle's wedge-shaped cutting point is used to work strong seams on non-woven fabrics like leather, suede and vinyl.

### STRETCH

Designed for sewing two-way stretch knits such as lycra and silk jersey. It prevents skipped stitches on fine knit fabrics.

### QUILTING

This will pierce multiple layers whilst keeping straight stitches so it is ideal for patchwork and machine quilting.

### TOPSTITCH

This has an extra-sharp point and eye, so thicker topstitching thread can be used. It's perfect for straight stitching with thicker threads on any type of fabric.

### TWIN

Used for parallel rows of stitching such as pintucks and hems.

## NEEDLE SIZE GUIDE

UK SIZE	US SIZE	FABRIC
60	8	Silks
70	10	Lightweight fabrics
75	11	Medium weight fabrics
80	12	Medium weight fabrics
90	14	Medium weight fabrics
100	16	Heavy weight fabrics
110	18	Upholstery fabrics/denim
120	20	Heavy canvas

## GLOSSARY

For a full glossary of sewing terms visit [www.simplysewingmag.com](http://www.simplysewingmag.com)

### DRAPE

A term used to describe the way a fabric hangs under its own weight. Different fabrics have different drape qualities.

### EASE

The addition of extra fabric in a pattern to allow the finished garment to fit the body well.

### EDGE STITCH

A row of stitching on the very edge of a garment, usually 2-3mm (1/16-1/8in) from the folded or seamed edge. Used to hold the fabric edge neatly in place.

### FACING

This pattern piece is cut separately to stabilise and create a neat finish on the edge of a garment, such as the neckline.

### FAT QUARTER

A term used to describe a cut piece of fabric often used for patchwork projects, usually measuring 46x55cm (18x22in).

### FINISHING/NEATENING RAW EDGES

This is done to stop the fabric edges, particularly of a seam, from fraying. It can be done by machine zigzag stitch, using an overlocker or trimming the raw edge with pinking shears.

### GRAIN/GRAINLINE

The lengthwise fabric grain, running parallel to the selvedge.

### NAP

Fabrics like velvet, corduroy and fur have hairs or loops which all lie in one direction and are called the nap, or pile. When cutting out pattern pieces make sure the grainline arrow always runs in the direction of the nap.

### NOTIONS

Small tools or accessories used

in sewing such as zips, fasteners, lace and buttons.

### RIGHT SIDE (RS) / WRONG SIDE (WS)

The right side of the fabric, also called the 'public' side, has the design on it. The wrong side is the other side – this is usually a little duller or faded on plain fabrics.

### SEAM ALLOWANCE

The fabric between the raw or cut edge of the fabric and the seam is called the seam allowance. Your pattern will tell you the required seam allowance measurement. This is usually 1.5cm (5/8in) for dressmaking, but can vary.

### SELVEDGE

The finished woven edge of fabric, often with the fabric name printed on it. The grain runs parallel to this and the bias diagonally. Called selvage in the US.

### STAYSTITCHING

A line of regular machine stitching usually worked 3mm (1/8in) inside the seam line, often used to stabilise curved edges to stop them stretching out of shape.

### TACK/TACKING

A line of temporary stitching used to hold fabric pieces together before machine sewing, worked in the same way as running stitch. Known as basting in the U.S.

### TOPSTITCHING

A line of stitching worked 5mm (1/4in) from the folded or seam edge. Used to hold the seam in place and as a decorative finish.

### UNDERSTITCHING

A line of stitching worked through the facing and seam allowance 3mm (1/8in) from the seam to stop the facing rolling to the outside of the garment. Understitching will not be visible on the outside.

## STITCH GUIDE

Use these basic hand stitches to complete your home and dressmaking projects.

### LADDER STITCH

Used to join together and close two turned-under edges invisibly, such as on a dress lining or soft toy. Bring the needle up at 1 on one side of the seam, then in at 2 on the opposite side and out at 3, so the stitch is 3mm (1/8in) long. Push the needle back in the opposite side at 4 and out at 5. Repeat this to close the edges.

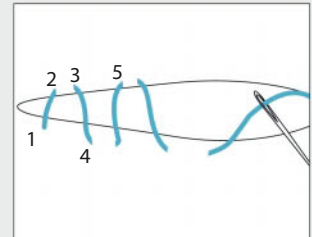

### SLIP STITCH

This stitch is used most often for hems where you need to stitch a turned-under edge to a flat piece of fabric using small, almost invisible stitches. Bring the needle up at 1 on the turned-under hem then back in at 2 and out at 3. Make this horizontal stitch as small as possible so it can't be seen from the front. Repeat this by making a vertical stitch back into the turned-under edge then continue in this way to complete the hem.

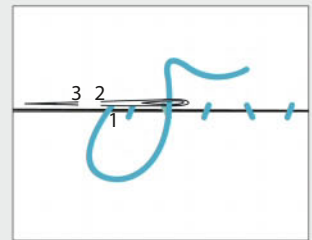

### WHIP STITCH

Whipstitch is used to join the edges of two fabrics together, such as felt and other fabrics that don't fray. With the right sides together, bring your needle out at 1 on the front of the fabric, then over to the back of the other, and through and out at 2. Continue to work small stitches close together over the top of the two fabric edges.

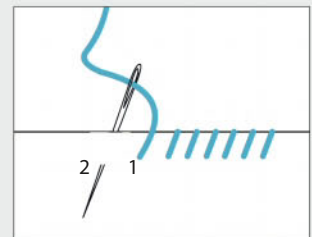

### RUNNING STITCH

This can be used to gather fabric and as a decorative stitch worked around the edge of a finished project. Bring the needle out at 1, in at 2, then out at 3 and in at 4, and so on. Make the length of the stitches the same length as the gaps between them for an even finish. You can work several running stitches on your needle at once.

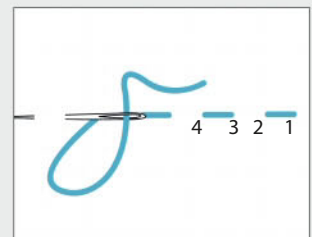

# NEXT ISSUE



Drape cardigan  
Liberty tie  
Jumper dress  
Umbrella hack  
Ruffle top  
Moccasin slippers  
Baby gifts  
Patchwork beanbag  
And more...

**+ FREE!**

**Cotton  
+ CHALK**

**PATTERN WORTH £8.99**



Stay cosy with this chic cover-up with two sleeve lengths and collar options to choose from (sizes 6-20).



**ON SALE THURS 25 JANUARY**

**WWW.SIMPLYSEWINGMAG.COM**



# A COUNTRY MILE

Designer Jenni Smith's home in Yorkshire provided both the materials and inspiration for her favourite coat.

"THIS COAT HAS A SPECIAL PLACE IN my heart for so many reasons. First of all, the tweed cloth is produced in a Yorkshire mill about five miles from my home. The colours remind me of the local moorland and seem to work with everything. However, the checks in the design are not square so it was a bit trickier to pattern-match than I first thought. I also managed to include a piece of Liberty tana lawn cotton for the inside pocket.

I used a Burda pattern for the basic shape but made a lot of changes to the original design – it was supposed to have a separate panel at the bottom with in-seam pockets but I wanted large welt pockets, and I added bound buttonholes which I made in a contrast corduroy. These were both new techniques to

me and so it was a challenging make.

I fell-stitched the lining in by hand – it is much neater on one side than the other and I definitely got better at it by the end. I found the buttons in my favourite shop in Ilkley where there are hundreds to choose from.

The coat is loose-fitting so I end up wearing it all the time because it works well over cosy woolly jumpers, covers my behind and can be easily dressed up or down. I already have the next one ready on my cutting table – in beautiful Linton tweed."

*Find Jenni's tutorials and patterns at [www.jenni-smith.co.uk](http://www.jenni-smith.co.uk) and on Instagram @jenni-smithsews, and tune into Freeview channel 78 to see her sew live on air on Sewing Quarter or catch up at [www.youtube.com/sewingquarter](http://www.youtube.com/sewingquarter)*

Stay in touch!

WWW.SIMPLYSEWINGMAG.COM • #SIMPLYSEWINGMAG

 facebook.com/simplysewingmagazine  twitter.com/simplysewing\_

 pinterest.com/simplysewingmag  instagram.com/simplysewingmag



# THE atelier SERIES



## atelier 3

A clear LCD screen helps you select from the 120 stitches including 7 auto 1-step buttonholes and alphabet.



## atelier 5

This machine has an incredible 91 needle positions and an easy change needle plate to enhance straight stitch performance at up to 1,000 spm.



## atelier 7

Quilters and designers will enjoy the AcuFeed Flex layered fabric feeding system and the automatic presser foot lift for easy pivoting.



## atelier 9

The atelier 9 is a combined sewing and embroidery machine. It introduces some brand new features such as the Stitch Tapering Function and it even has Wi-Fi!

Designed for every type of sewing, these contemporary styled, well illuminated, free-arm sewing machines with easy to use computerised features are perfect to take your sewing to a new level. The larger arm space and superior feeding system ensure they are equally suited to both larger projects and precision sewing.



SMART  
ELEGANT  
SOPHISTICATED

For further information:  
Telephone 0161 666 6011 or visit [www.janome.co.uk](http://www.janome.co.uk)

The world's leading sewing machine manufacturer

**JANOME**

ISSUE 38  
TEMPLATES  
MAKE!

# Simply Sewing

FRESH IDEAS WITH FABRIC

PRESS TO  
DOWNLOAD  
TEMPLATES

FRONT  
(1x F)

BACK LEG  
(Fabric A)

FRONT  
(2x F)

BACK SHOE  
(2x Fabric B)

OR DOWNLOAD ISSUE 38 TEMPLATES AT  
[www.simplysewingmag.com/category/downloads](http://www.simplysewingmag.com/category/downloads)

