

Woodsmith®

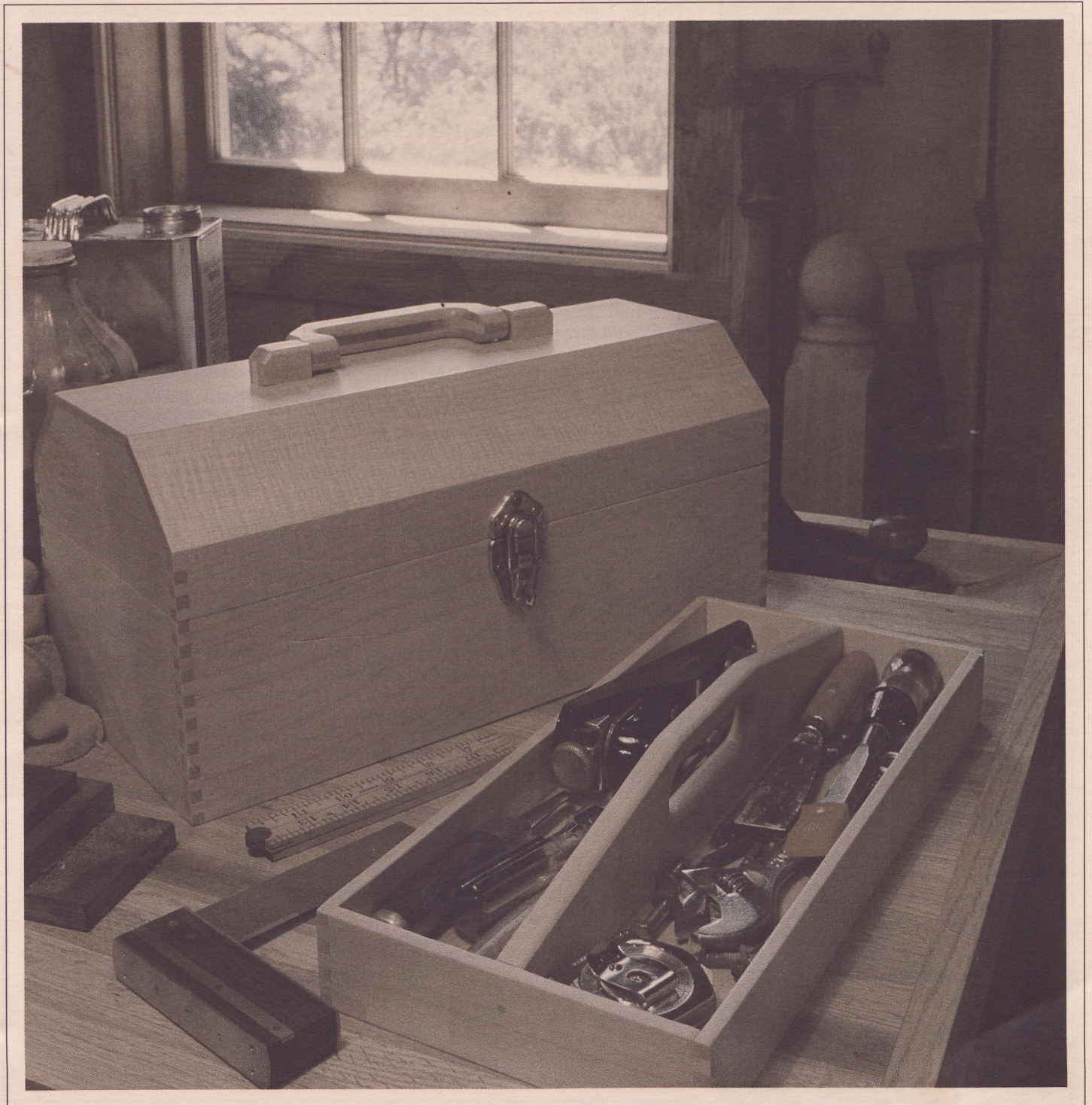

Woodsmith®



Editor **Donald B. Peschke**
 Design Director **Ted Kralicek**
 Managing Editor **Douglas L. Hicks**
 Assistant Editors **Douglas M. Lidster**
Kent A. Buckton
Terry J. Strohman
 Project Designer **Ken Munkel**
 Technical Illustrators **David Kreyling**
Cary Christensen
Rod Stoakes
Chris Glowacki
 Customer Service **Sandy Baum, Mgr.**
Jackie Straub
Pat Koob
Lisa Thompson
 Project Supplies **Leslie Ann Gearhart**
 Computer Operations **Ken Miner**
 Administrative Assts. **Cheryl Scott**
Jean Carey
 Building Maintenance **Archie Krause**

WOODSMITH STORES

Operations **Steve Krohmer**
 Marketing Manager **Steve Dozier**
 Store Managers:
 St. Louis, MO **Jon Behrle**
 Berkeley, CA **Michael DeHaven**
 Des Moines, IA **Kent Welsh**

WOODSMITH (ISSN 0164-4114) is published bimonthly (February, April, June, August, October, December) by Woodsmith Publishing Co., 2200 Grand Ave., Des Moines, IA 50312.

Woodsmith is a registered trademark of Woodsmith Publishing Co.

©Copyright 1989 by Woodsmith Publishing Co. All Rights Reserved.

Subscriptions: One year (6 issues) \$12.95, Two Years (12 issues) \$22.95. Canada and Foreign: add \$2 per year, U.S. funds only. Single copy price, \$3.50.

Second Class Postage Paid at Des Moines, Iowa.

Postmaster: Send change of address to Woodsmith, Box 491, Mt. Morris, IL 61054.

SUBSCRIPTION QUESTIONS? Call 800-435-0715 (IL residents: 800-892-0753). 7:30 AM to 8:30 PM, CST, weekdays.

BACK ISSUES: For a booklet describing back issues, send to address above.

SAMPLE COPY: We will send a free sample copy of *Woodsmith* to anyone. Just send us his/her name and address.

Sawdust

If someone suggested to me that we ought to build a toolbox as a project in *Woodsmith*, I would immediately think of one of those wooden cases with all the drawers in it — an engineer's case.

But the toolbox we're showing in this issue is more like the metal boxes designed to hold automotive tools or fishing gear.

Why this style? Why not the big case?

This project didn't start out as a project for *Woodsmith*. It started as a solution to a rather simple problem. Ted (our design director) needed a small case to carry some tools around.

He likes to use some of his own hand tools in the *Woodsmith* shop when building projects for the magazine. But he also needs them in his shop at home, too. So he built a toolbox that would hold his jack plane, a block plane, some favorite chisels (a beat up one for hacking around, and a set of good paring chisels), and an assortment of other hand tools.

Okay, Don, what's the point of this story? The point is that I had to do some thinking about basic practicality. The fancy engineer's case (that I've always wanted to build) is not very practical for storing wood-working tools. While the metal toolboxes (that I don't particularly like) are much more practical.

What ultimately changed my mind was the fact that the toolbox Ted built for himself was made out of 1/4" maple and joined with box joints. It took on a completely different look and feel than the metal boxes, even though the basic shape is the same.

When I first saw it, my reaction was, this looks pretty neat. But as my practical mood returned, I wondered if a toolbox made of thin wood would hold up for long. Ted's has now lasted more than a year with more and more tools crammed into it all the time.

Is it practical? Yes. Am I surprised? Yes, I have to say that this project surprised me. It's one I wouldn't have thought I would want to build, but now I would have a hard time giving it up.

THIN LUMBER. Even more surprising was the strength and durability of the thin wood used to make the toolbox. I would have assumed that this box would not last long, especially with a lot of heavy metal tools banging around inside.

But maple is exceptionally strong — even when it's only 1/4" thick. After a year that's given it a lot of use, the maple box shows little sign of wear. Not bad for a wooden box that "ought" to be made of metal.

Now that I'm on the subject of thin lumber, it's time to say that in the past we've often avoided projects specifically because they require thin lumber. It's not easy to buy at lumberyards or even speciality stores. It's even harder to make it yourself — if you don't have a thickness planer.

So it was time to come up with some alternatives. The traditional method is to resaw thicker lumber into thin pieces and use a hand plane to smooth it to final thickness. Since I like using hand planes, this is the method I'd choose.

That is, except when planing maple (as I needed for the toolbox). Talk about aerobic exercise — hand planing even small pieces of maple will get the ol' heart pumping.

It only took a few boards before I wanted a way to let a motor do the work. The router jig we came up with (shown on page 13) works great. Even though you have to make a lot of passes over the surface, it comes out fairly smooth. And it cleans up quickly with a hand scraper and a little sanding.

Am I getting lazy, letting a motor do the work? Maybe I'm just getting practical.

BOOKMATCHING. One of the nicest effects you can create when making thin lumber is bookmatching. If you need a wide thin panel, it can be made by resawing a board in half and joining (bookmatching) the two pieces together.

When I made the thin panel for the chisel case (page 8) I resawed a piece of 3/4"-thick walnut that had a nice swirl pattern in the grain. If you have the chance to try this technique, look for a piece of wood with some character. Avoid "perfect" pieces with nice straight grain. I look for a piece with "defects" like knots, or spalting, or a crazy grain pattern. Although a bookmatched panel with wild grain is difficult to plane, it sure creates a spectacular effect.

NEW FACES. I usually try to mention new people joining us here at *Woodsmith*. Although Terry Strohman isn't new to *Woodsmith*, he now has a new responsibility.

For the past few issues Terry has been handling the Sources page, and in the process, learning the way we go about putting together an issue of *Woodsmith*.

With this issue, I asked Terry to contribute more by writing one of the project articles. He was delighted to help, and we've all benefited by having one more source of knowledge.

NEXT ISSUE. The August issue of *Woodsmith* (No. 64) will be mailed during the week of August 28, 1989.

Tips & Techniques

ROUTER BIT HOLDER

When mounting a router bit, you don't want the bit to "bottom out" in the collet. The problem has to do with the transition fillet that's between the cutting head and the shank on most router bits. If the shank of the bit

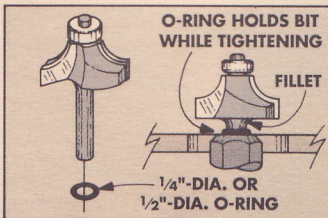

drops all the way down, the collet will grab around the fillet and not the whole shank.

So, you raise the bit up a little, until the collet only contacts the

shank. To do this only takes three hands: one to hold the bit up, and the other two to tighten the collet with two wrenches.

Or, you can slip a rubber O-ring around the shank of the bit. The O-ring will hold the bit at the correct height above the collet, and then you'll have both hands free to tighten down the bit.

I picked up some of these rubber O-rings for about 20 cents apiece at a local hardware store. (For a 1/4" shank you'll need to use a 1/4" O-ring and for a 1/2" shank use a 1/2" O-ring.) Just roll the O-ring onto the shank until it's about a 1/4" from the transition fillet.

*Melvin Evans
Meridian, Idaho*

SANDPAPER CUTTING JIG

Trying to cut uniform pieces of sandpaper for an orbital sander is a hassle. To make it easier, I built a sandpaper cutting jig.

The base of the jig is a square of plywood with V-grooves routed at measured widths to guide a shop knife. To make the base, I cut a piece of 3/4"-thick plywood to 12" x 12".

Next, determine how many pieces of sandpaper you can get out of one sheet for your sander. The standard size of a sheet of sandpaper is 9" x 11". Most orbital sanders use 1/3 of a sheet, 1/4 of a sheet, or even 1/6 of a sheet.

Once you know the sheet size, lay out the position of the cut lines on the top of the base. Since there are two 1/2"-wide stops

glued onto one corner later, start 1/2" from one edge.

Now rout V-grooves 1/8" deep along the layout lines to serve as a cutting trough for the knife.

Then I added two strips at one corner to form a stop for the sandpaper, see drawing. Since the stop gets in the way of the knife blade, I cut a kerf through the stop with a hand saw, aligning the kerfs with the V-grooves.

To use the sheet cutter, place a couple of sheets of sandpaper upside down on the base with a corner against the stops. Now cut through the sheets. Move the just-cut edge against the stops and repeat the cut.

*Greg Hiltbrand
Beale AFB, California*

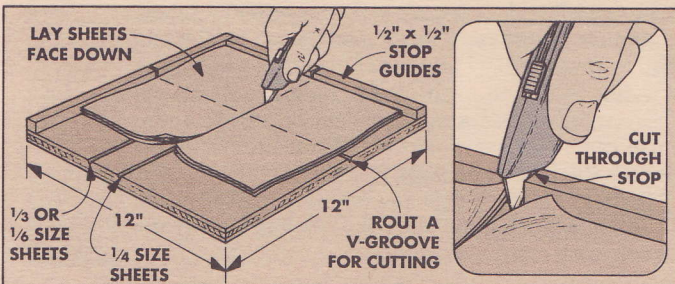

C-CLAMP TABLE

I have an extra "workbench" made out of a piece of plywood that sits on top of two old sawhorses. I use this bench for all types of work, especially sanding. But while sanding, the workpiece tends to slide around.

To hold the workpiece in position, I created a simple "poor-man's" clamp.

This idea uses ordinary C-clamps that fit through oval windows in the plywood, see drawing.

To cut the ovals, mark areas on the table top where you would most likely clamp pieces.

My rule of thumb for measuring the width of the oval is to measure the width of the neck on the C-clamp, then add 1".

To get the length, add 2" to the width of the oval. Now lay out the ovals at the location marks on the table. Drill holes at both ends of the ovals and cut between the two holes with a sabre saw.

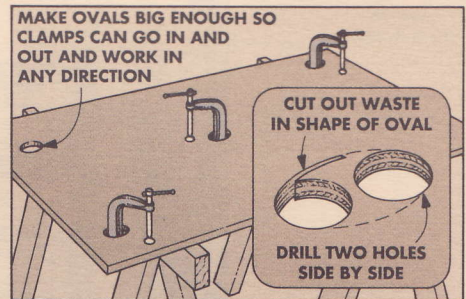

To use the table, slip a C-clamp through the oval and then tighten your workpiece to the table.

*Mike Francioli
Niagara Falls, New York*

GLUING EDGING

In *Woodsmith* No. 62 there's a technique on how to clamp thin edging to plywood using a clamping board with a rounded edge. This works fine, but I had problems keeping long thin edging strips from sliding while clamping and gluing.

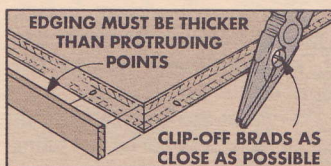

To keep edging from sliding, drive thin brads about every 12" along the edge of the plywood and snip them off so a point protrudes. Then apply glue to the strip and align it with the edge. Press the strip against the first brad point, then repeat down the length of the edge. (Note: Edging strips must be thicker than the length of the protruding points.) Now clamp the strip in place.

*David Warren
Martinez, California*

PANEL RATTLE

To allow for expansion when making raised panels, I usually cut the panel a little narrower. Sometimes, though, the panel will rattle inside the grooves of the frame.

To fix this problem, I cut narrow strips of self-sticking foam insulation tape (1/8"-thick). When the tape is stuck to the bottom of the groove in the frame, it keeps the panel from rattling, and also allows room for expansion. Insulation tape can be found in most hardware stores.

*George Seifert
Shoreview, Minnesota*

SEND IN YOUR TIPS

If you'd like to share a tip with others, send in your idea to *Woodsmith*, Tips & Techniques, 2200 Grand Ave., Des Moines, Iowa 50312.

We pay \$15 for accepted tips. Please send an explanation and a sketch if needed (we'll draw a new one).

Bookshelf

This bookshelf is easy to build, easy to knock down, and it's sturdy. So, why should that be surprising? It's all done without using permanent joinery or hardware to hold the shelves to the end frames.



The primary design feature of this bookshelf is one you can't see. There's no hardware. In fact, there's no permanent joinery holding the shelves to the end frames. It all "knocks down" because the shelves can be lifted right off the end frames.

The shelves rest on dowels in the end frames. This makes the whole unit easy to knock down by just lifting the shelves off the end dowels.

Okay, that makes it easy, but it can't be very sturdy, right? Well, the sturdiness comes from stiffeners that are added to the back edges of the shelves. These stiffeners are cut to fit tight between the end frames to prevent racking (sideways movement). They also serve other purposes. They keep the shelves from bowing under weight, and they work well as back stops for books so they don't slide off the back edge.

MATERIALS. I used $\frac{3}{4}$ "-thick red oak to build the shelves and the end frames of the bookshelf. I also used oak dowels in the end frames to match the other parts of the bookshelf. (If you can't find oak dowels, any hardwood dowels will work.)

SHELVES. One of the first considerations when buying the lumber for a project like this is getting stock that's wide enough for the shelves ($9\frac{1}{2}$ " wide). Although that might be the easiest approach, it may not be the best. Wide stock tends to warp easily. Since the shelves in this bookshelf are not mounted into dadoes in the end frames, they are particularly susceptible to warp as time goes on.

I prefer to glue up a couple of narrower strips to make each shelf. The different grain patterns in each strip will help prevent warp. We've shown the Cutting Diagram with this approach of two strips for one shelf.

RADIUS CORNERS. There's one feature on the end frames that's typical on a lot of furniture projects — a radius is cut on each corner to soften it. To cut these radii, I used a method that produces a uniform radius on every corner. Check out this procedure in the tip box on page 7.

FINISH. I finished this bookshelf using two coats of satin polyurethane varnish, sanding lightly between each coat.

EXPLODED VIEW

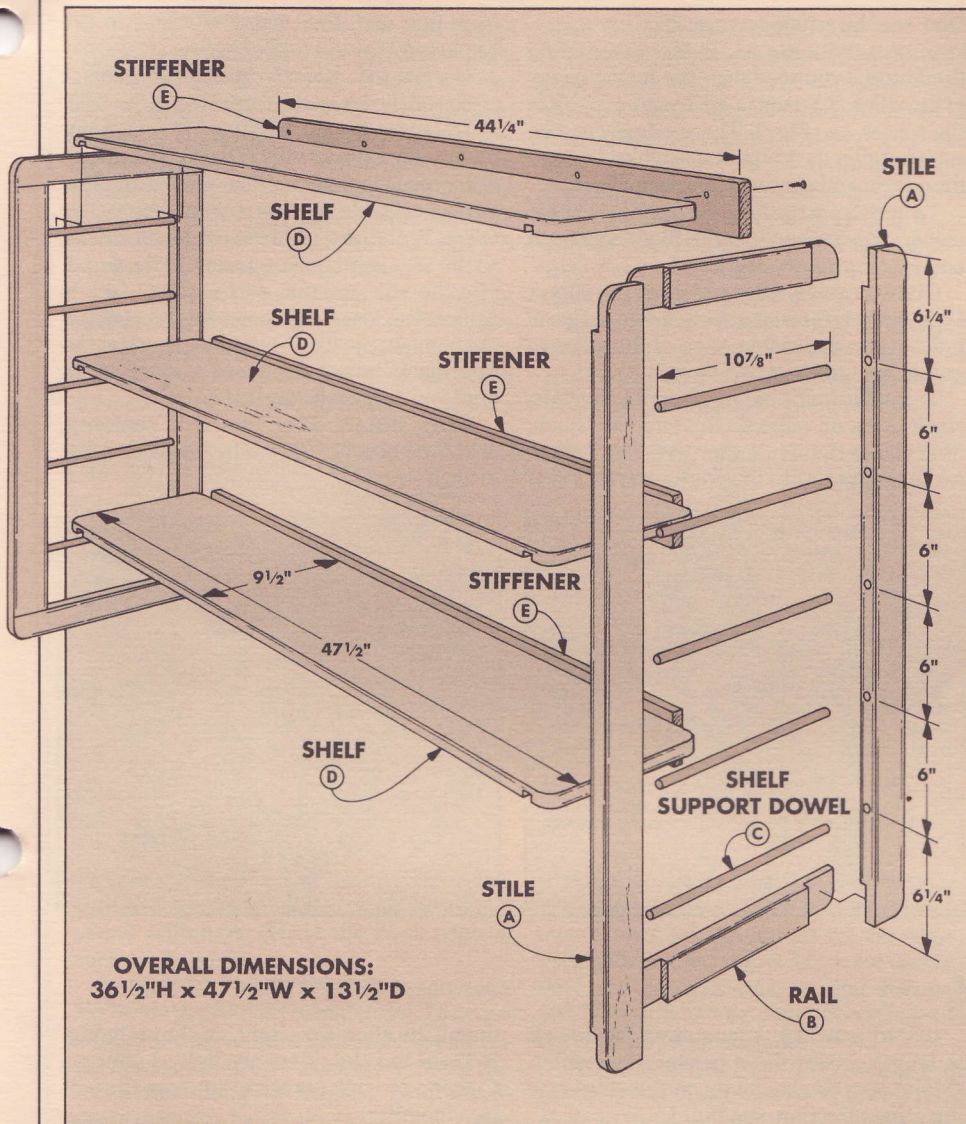

CORNER/STIFFENER

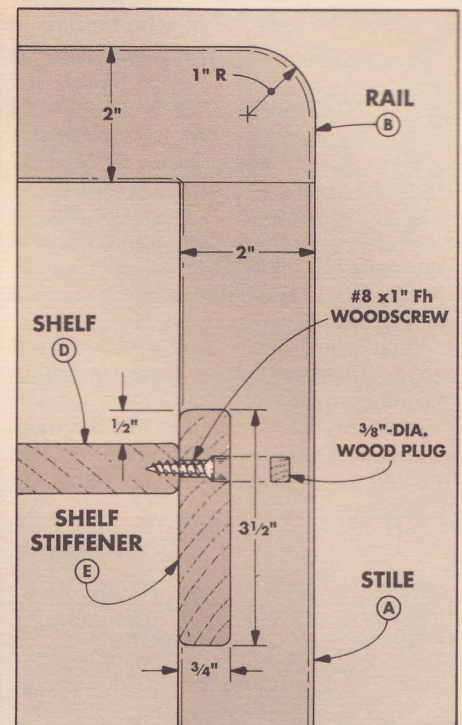

SHELF/DOWEL

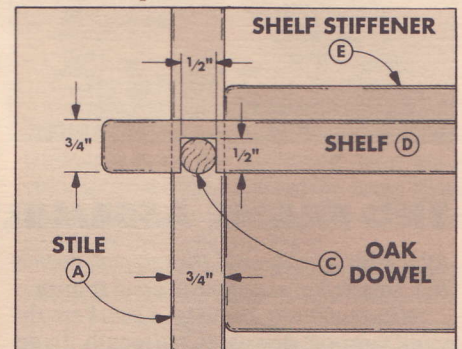

CUTTING DIAGRAM

3/4" x 7 1/2" - 96 (5 Bd. Ft.)		
A	B	E
A	B	E
A	B	E
3/4" x 4" - 96 (2.6 Bd. Ft.)		
A	B	E
3/4" x 5 1/2" - 96 (3.6 Bd. Ft. Each)		
D		D
D		D
D		D
		<p>EXAMPLE: EDGE GLUE TWO "D" BOARDS TO MAKE ONE SHELF. FOR MORE ON EDGE-GLUING, REFER TO WOODSMITH NO. 32</p>

MATERIALS LIST

A Stiles (4)	3/4 x 2 - 36 1/2
B Rails (4)	3/4 x 2 - 13 1/2
C Shelf Sup. Dowels (10)	1/2 x 10 7/8
D Shelves (3)	3/4 x 9 1/2 - 47 1/2
E Shelf Stiffeners (3)	3/4 x 3 1/2 - 44 1/4

SUPPLIES

LUMBER

- 18.5 Board ft. 3/4"-thick, solid red oak
Other choices might be birch or maple
- 4 - Three ft. oak dowel rods, 1/2"-dia., or other 1/2"-dia. dowel rods

HARDWARE

- 15 - #8 x 1" Fh woodscrews

FINISH

- Varnish: Two coats of satin polyurethane, sand lightly between coats

EXPLODED VIEW

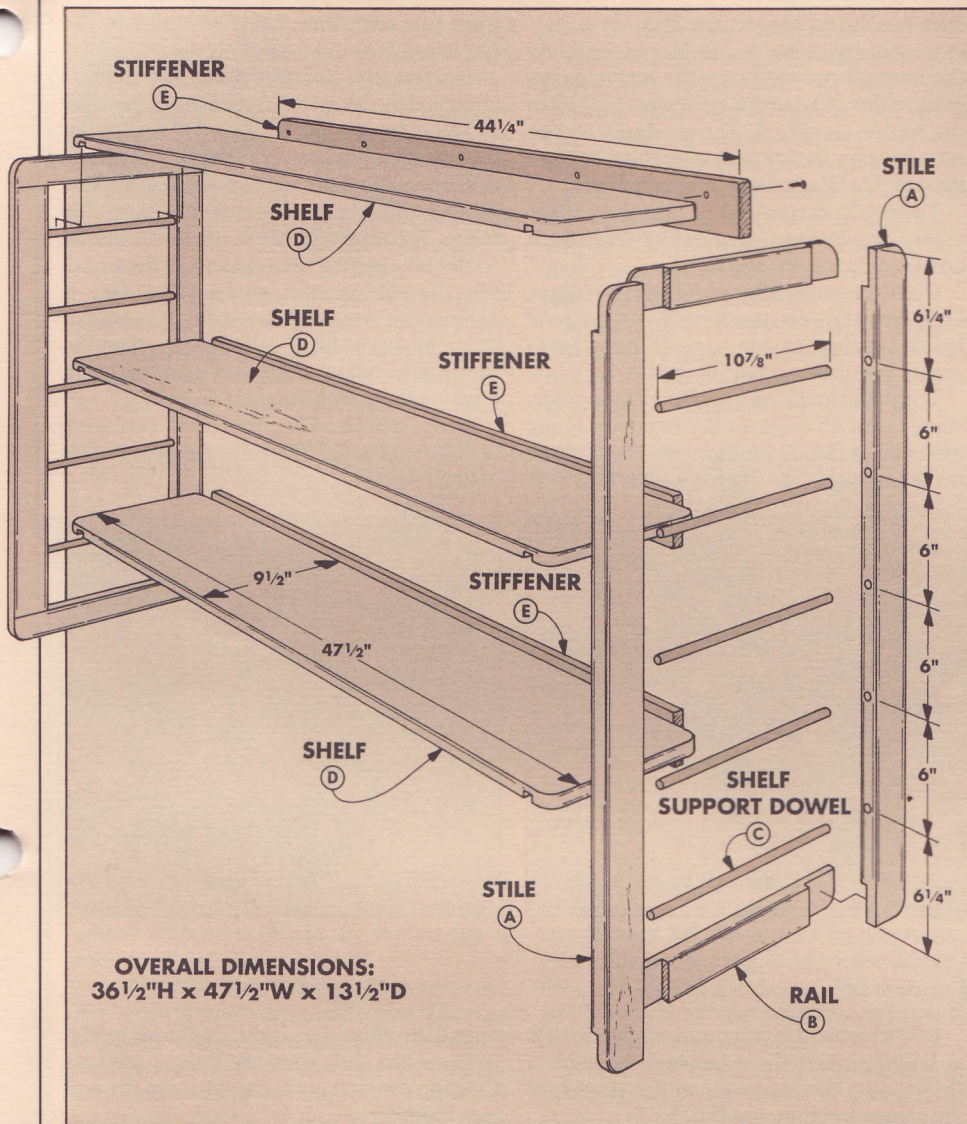

CORNER/STIFFENER

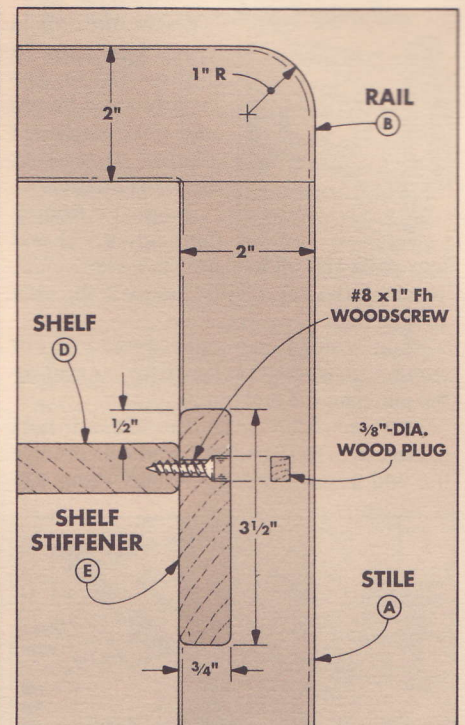

SHELF/DOWEL

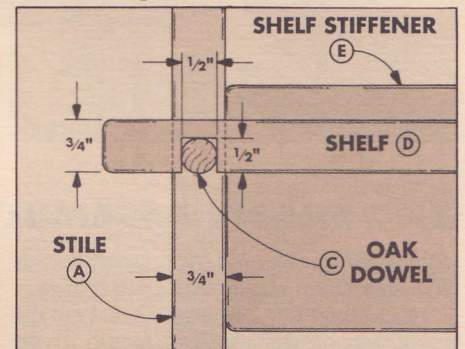

CUTTING DIAGRAM

3/4" x 7 1/2" - 96 (5 Bd. Ft.)		
A	B	E
A	B	E
A	B	E
3/4" x 4" - 96 (2.6 Bd. Ft.)		
A	B	E
3/4" x 5 1/2" - 96 (3.6 Bd. Ft. Each)		
D		D
D		D
D		D
D	EXAMPLE: EDGE GLUE TWO "D" BOARDS TO MAKE ONE SHELF. FOR MORE ON EDGE-GLUING, REFER TO WOODSMITH NO. 32	
D		

MATERIALS LIST

A	Stiles (4)	3/4 x 2 - 36 1/2
B	Rails (4)	3/4 x 2 - 13 1/2
C	Shelf Sup. Dowels (10)	1/2 x 10 7/8
D	Shelves (3)	3/4 x 9 1/2 - 47 1/2
E	Shelf Stiffeners (3)	3/4 x 3 1/2 - 44 1/4

SUPPLIES

LUMBER

- 18.5 Board ft. 3/4"-thick, solid red oak
- Other choices might be birch or maple
- 4 - Three ft. oak dowel rods, 1/2"-dia., or other 1/2"-dia. dowel rods

HARDWARE

- 15 - #8 x 1" Fh woodscrews

FINISH

- Varnish: Two coats of satin polyurethane, sand lightly between coats

STILES AND RAILS

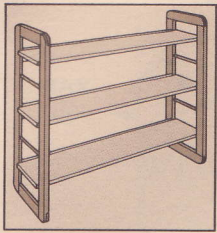

This bookshelf is relatively easy to build—there are only two end frames and three shelves. I started by making the two end frames.

Begin by ripping four **stiles (A)** and four **rails (B)** all to a uniform width of 2". Then cut the stiles 36½" long and the rails 13½" long.

Shop Note: I also went ahead and cut some extra pieces that I used for test cutting the joints on the end frame.

END LAPS. After cutting the stiles and rails to size, they're joined with end laps to form the end frames. (For more on cutting end

laps, see the article on page 20.)

ROUND OVER EDGES. Before assembling the frame, I rounded over the inside edges of the stiles (A) using a ⅛" round-over bit in the router, see Fig. 1. These edges can't be rounded after the frame is assembled because the dowels will be in the way, refer to Fig. 5.

To keep from routing into the joints on the stiles, I laid out reference marks to drill a series of holes down the inside edge of the stiles to mount the shelf support dowels (C).

LAYOUT HOLES. After rounding the edges, I laid out reference marks to drill a series of holes down the inside edge of the stiles to mount the shelf support dowels (C).

To get the marks aligned on all four stiles, stack them on edge so the ends are flush, then clamp them together, see Fig. 2. Now make marks across the edges, starting 6¼"

from one end, then every 6", refer to the Exploded View on page 5.

CENTER BIT. Before drilling the holes, I centered the bit on the thickness of the stile.

To center the bit, insert a ½" brad-point bit into the chuck, then clamp a 2x4 on the drill press table for a fence, see Fig. 3. Now put the outside face of a stile against the fence. With the drill press off, lower the bit so the bit's point makes a mark in the wood. Flip the stile around, so the other face is against the fence and lower the bit again. If the point on the bit doesn't exactly enter the first mark, adjust the fence and try again until you make one mark.

DRILL HOLES. After the bit is centered, drill five holes ¾" deep into the inside edge of each stile (A).

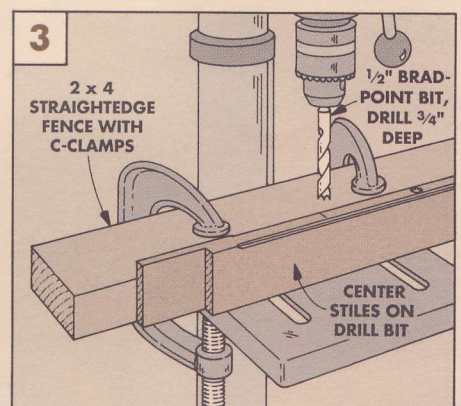
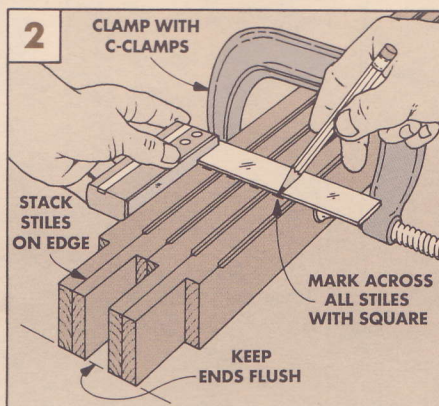
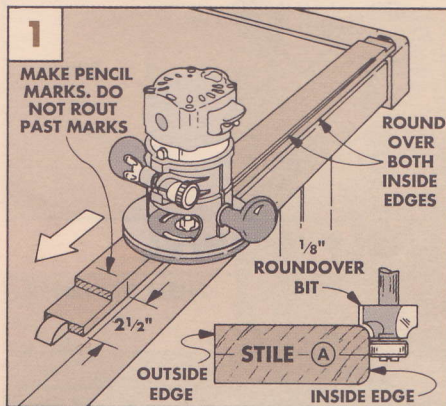

END FRAME ASSEMBLY

After drilling holes for the support dowels (C), I started to assemble the end frames.

SHELF SUPPORT DOWELS. First, I cut the shelf support dowels (C) to length. To determine the length, measure the distance between the shoulders of the rails (9½"), see Fig. 4. Then add to this measurement the depths of two holes in the stiles. Now cut ten ½"-dia. dowels ⅛" less than this total so they won't bottom out.

INSERT DOWELS. After cutting the dowels to length, insert them between two stiles. (Make sure the lap joints on the stiles face the same direction, see Fig. 4.)

ASSEMBLY. To complete the assembly of the end frame, lay the stile assembly flat across two pipe clamps so the end laps face up, see Fig. 5. Next apply glue to the end laps on the rails (B) and clamp them to the end laps on the stiles (A) using three pipe clamps

to pull the shoulders tight, as shown in Fig. 5. Once the shoulders are tight, I added a C-clamp on each corner to squeeze the end laps together.

RADIUS. After the glue dries, I cut a 1" radius on all corners, refer to the tip box on the opposite page.

ROUND OVER. After cutting the radius corners, finish rounding over the inside and outside edges of the end frame, see Fig. 5a.

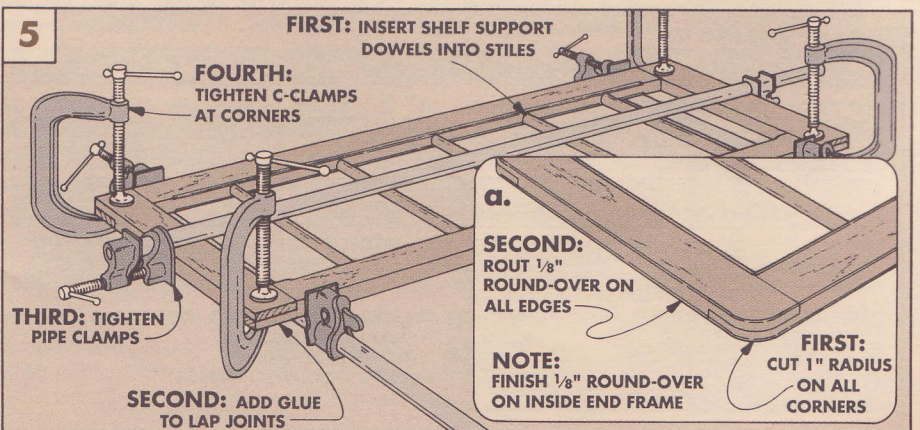
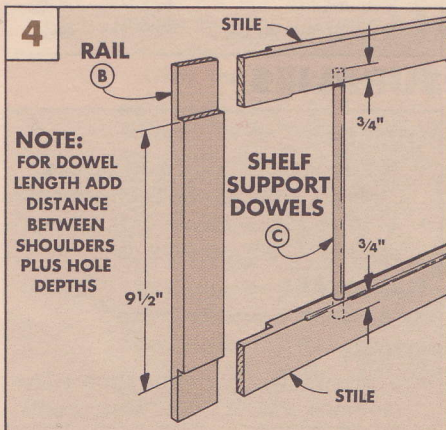

SHELVES

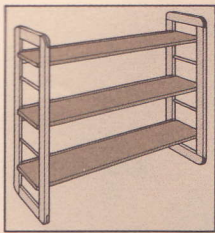

After the end frames are finished, work can begin on the three adjustable shelves (D). To prevent the shelves from warping, I edge-glued two boards together to make a shelf blank 11" wide by 48" long.

CUT TO SIZE. After the glue dries, cut the shelves to a finished length of 47½". To determine the width, measure the distance between the inside edges of the end frames. Then cut the shelves ¼" less to

allow for expansion/contraction.

DADOES. After cutting the shelves to width, I cut dadoes on the bottom of each shelf to fit over the shelf support dowels (C). Set the fence 1⅛" from the inside of a ½"-wide dado blade, see Fig. 7. Now sneak up on the final depth of the dado by raising the blade and making a pass on a scrap piece until a shelf support dowel fits flush with the bottom of the shelf. Once set, cut dadoes on the bottom face at both ends of all three shelves.

RADIUS AND ROUND OVER. To complete the shelves, cut a 1" radius on the corners of all shelves, see tip box at right. Then round over all the edges with an ⅛" round-over bit.

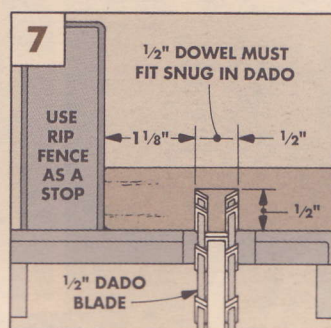
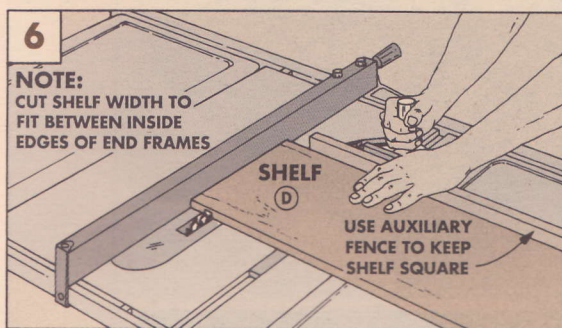

RADIUS CUTTING

One of the best ways to round consistent corners is with a template and flush-trim router bit. Make the template by cutting a piece of Masonite 8" square. Then use a compass to lay out a 1" radius on one corner. Cut the radius oversize, and carefully clean to the line using a disc sander.

To use the template, stick it down on a corner of the workpiece using double-sided carpet tape. Now set the height of a flush-trim bit so the bearing rides only on the template. Cut the radius in several passes, until the bearing rides completely around the radius of the template.

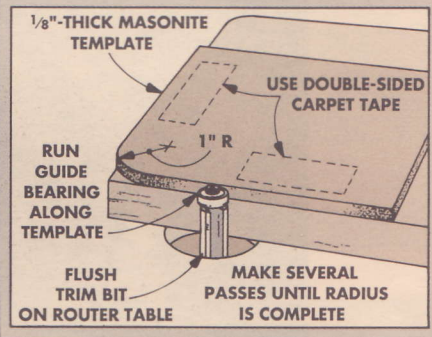

ASSEMBLY

To keep the shelves from bowing and to prevent the whole bookshelf from racking, I added stiffeners (E) to the back edge of each shelf, see Fig. 8.

CUT TO SIZE. Start by ripping enough stock 3½" wide to make three stiffeners. To determine the final length, assemble the bookshelf, and measure the distance between the end frames along the shelves. Cut the stiffeners to length by starting a little long, then sneak up on the finished length. Check the fit between the end frames after each cut until you get a snug fit.

ROUND EDGES. After cutting the stiffeners, round over the edges and ends, see Fig. 8a.

DRILL HOLES. Next, to fasten the stiffeners to the shelves, lay out a series of counterbored shank holes 7/8" down from the top edge of each stiffener, see Fig. 8. Mark the center of the holes starting 2" from one end, then every 10". Now drill 3/8"-dia. counterbore holes ¼" deep, then 3/16" shank holes.

STIFFENER HEIGHT. After drilling the holes, the stiffener can be screwed to the shelf so the top edge of the stiffener is ½" above the top face of the shelf. To make sure this height is uniform down the length of the shelf, I made a spacer block out of a piece of scrap with a ½" notch cut out of one corner, see Fig. 9.

FASTEN STIFFENER. Now to fasten the stiffeners to the shelves, lay the front of the bookshelf down flat, see Fig. 8. Next lay a stiffener on the back edge of the shelf. Then use the spacer to align the stiffener so it's ½" above the shelf, see Fig. 9.

When the stiffener is aligned, drill a pilot hole and screw the stiffener down with a No. 8 x 1" Fh woodscrew. After fastening, move the spacer block to the other end of the shelf and repeat the procedure.

PLUGS. With all the screws down tight, I glued 3/8"-dia. wood plugs into the counterbored holes in the stiffeners, and then trimmed them flush.

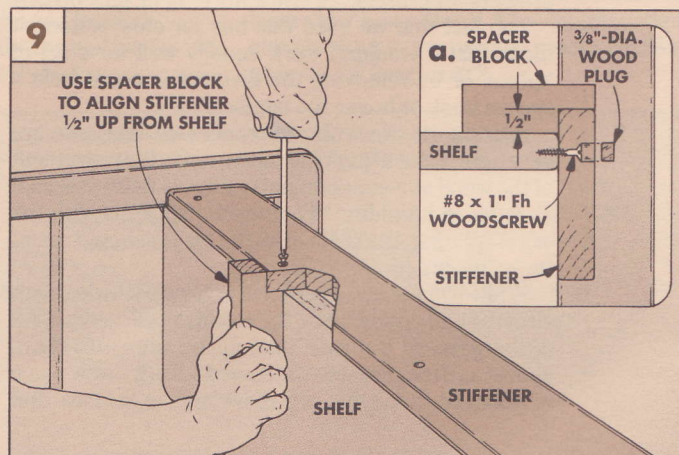
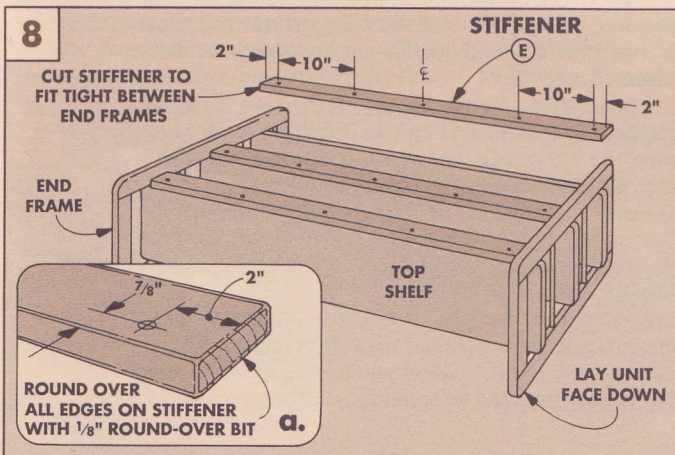

Chisel Case

This case protects your favorite chisels and doubles as a working chisel stand. Instead of complicated joinery, this project relies on a precise fit and understanding the natural movement of wood.

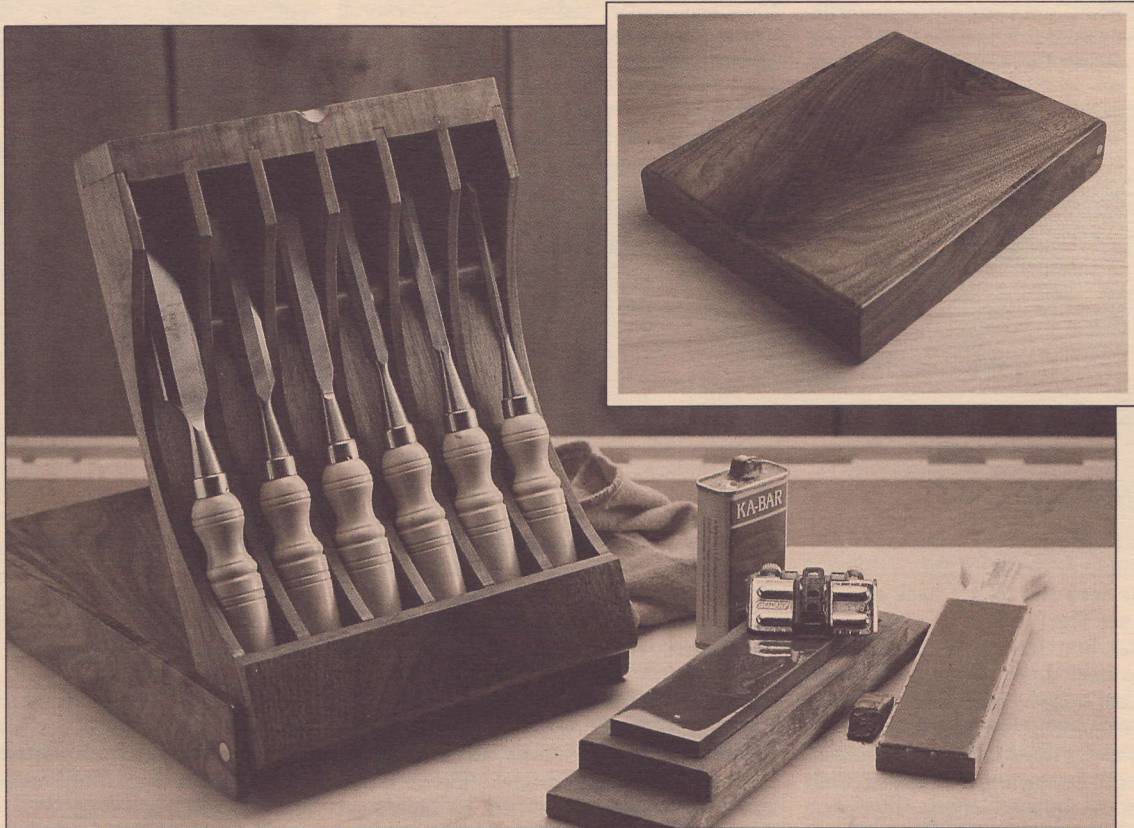

I have a fondness for unique containers. That's why I am intrigued with this project. It not only holds and protects the chisels, it's also a working display box.

The fact that we used this box for chisels doesn't mean that it wouldn't work equally well for a set of knives, or by removing the dividers, it could hold a special book or house the family album.

END GRAIN. Since the tolerances on this case are very tight, I had to pay close attention to the movement of the wood as it expands and contracts (with seasonal changes in humidity). To prevent problems with the wood splitting, the grain of all the pieces should run in the same direction.

While it may seem like a lot of extra work to deal with all of the end grain pieces, the result is well worth it. All of the grain in the case runs in the same direction, almost as if the case were hollowed out of a single piece of wood. By doing this, any movement in the case that

should occur will not open any of the joints or cause cracks to develop.

JOINERY. While the joinery in this project is not complicated, precise fits are very important. For most pieces, I recommend they be cut oversized, and then trimmed to fit.

WOOD. When choosing wood for the case, try to use hardwoods that have been kiln dried. No matter how carefully the case is constructed, using wood with a high moisture content will cause problems.

I built this case out of walnut. The handles on the chisels are light colored and the dark background makes them stand out. Walnut is stable and relatively easy to work with.

FINISH. After completing the case, the interior and the exterior were finished with three coats of hand-rubbed tung oil. If you feel you need a more durable finish, polyurethane will offer more protection.

EXPLODED VIEW

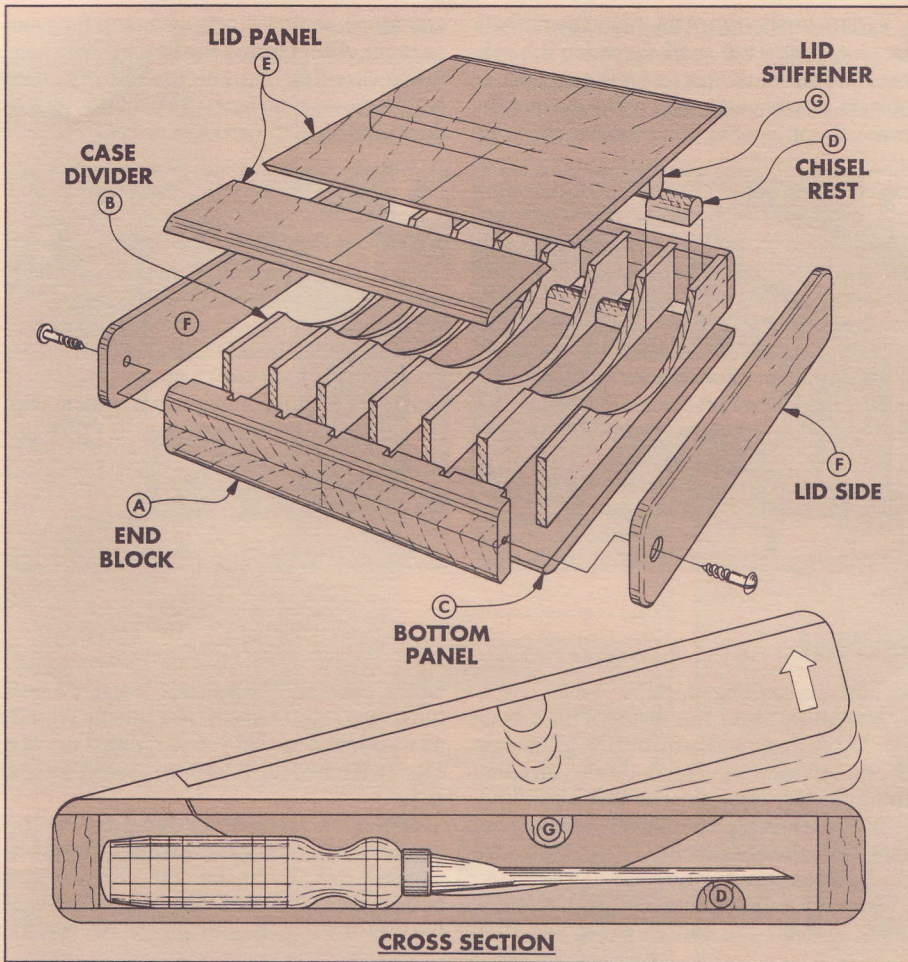

MATERIALS LIST

TRAY

A	End Blocks (2)	1 1/2 x 9 1/4 - 7/8
B	Case Dividers (7)	1/4 x 1 1/2 - 11 1/4
C	Bottom Panel (1)	1/4 x 9 1/4 - 12 1/2
D	Chisel Rests (6)	3/4 x 1 1/4 - 1/2

LID

E	Lid Panel (1)	1/4 x 9 1/4 - 12 1/2
F	Lid Sides (2)	1/4 x 2 - 12 1/2
G	Lid Stiffener (1)	3/4 x 9 1/4 - 1/2

CUTTING DIAGRAM

1/4" x 3 1/2" - 36" (.9 Sq. Ft.)

B	B	B
B	B	B

1/4" x 5" - 38" (1.3 Sq. Ft. Each)

C	C	B
C	C	B

E	E	F
E	E	F

3/4" x 5" - 16" (.6 Bd. Ft.)

A, D, G

SUPPLIES

LUMBER

- 3.5 Sq. ft. 1/4"-thick walnut
- .6 Board ft. 3/4"-thick walnut

HARDWARE & FINISH

- (2) No. 12 x 1 1/4" Rh brass woodscrews
- Tung oil
- Paste wax

LAY OUT THE END BLOCKS

I started work on the chisel case by determining the width of the **end blocks (A)**. The width depends on three things: the width of your widest chisel, the number of chisels, and the thickness of the tray dividers.

DETERMINING THE WIDTH. Measure the widest part of your largest chisel, add 1/8" for clearance, and this will be the width of each tray section. (The largest chisel in my set is 1 1/8" wide, so each tray section is 1 1/4" wide.)

Once you know the size of each section, you can multiply that figure times the num-

ber of chisels you have. (I have six chisels so $6 \times 1 1/4" = 7 1/2"$.)

Also, determine the total thickness of the tray dividers. (Since I used seven 1/4"-thick dividers the total thickness of all of the dividers is $1 3/4"$.)

Now, add the total width of the tray sections ($7 1/2"$) and the total thickness of the dividers ($1 3/4"$) to get the total width ($9 1/4"$) of the case tray (and the end blocks).

END BLOCKS. To make the end blocks (A), I edge-glued enough 3/4"-thick stock to form

a blank 10" wide by 8" long, see Fig. 1.

When the glue is dry, trim both ends and then cut off a 6"-long piece, leaving a 1 7/8" piece, see Step 1. (Save the short piece for later use.) Now, rip the 6"-long piece to the finished width for your end blocks ($9 1/4"$).

To get the thickness needed for the end blocks, cut the 6"-long pieces in half and glue these two pieces together face-to-face to form a block, see Step 2. After the glue dries, cut this block to get two end blocks (A) $9 1/4"$ wide by 7/8" long, Step 3.

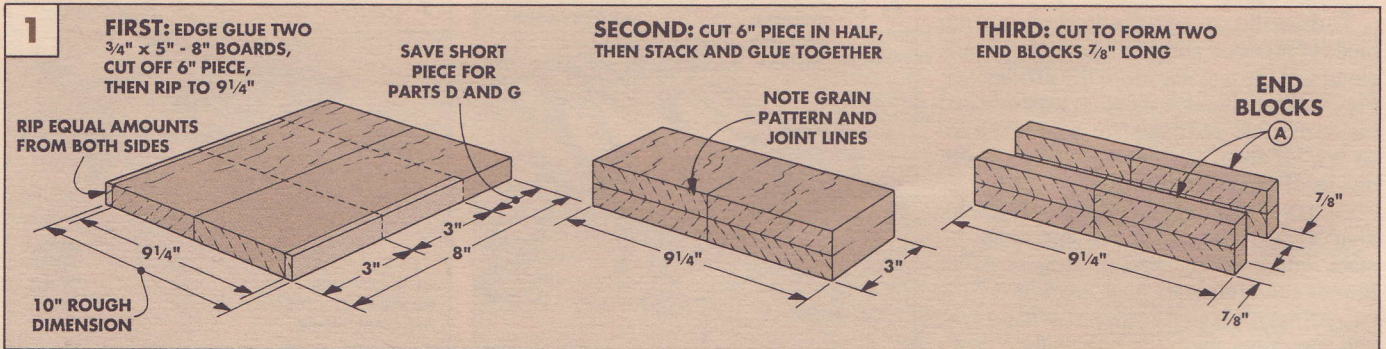

CUTTING THE GROOVES

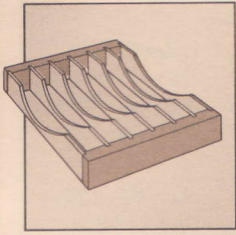

After making the end blocks, $\frac{1}{4}$ " rabbets and grooves are cut to hold the case divider (B). (Cut the rabbets and grooves to match the actual thickness of the dividers.)

SET THE DADO BLADE. Begin by setting the saw to cut a $\frac{1}{4}$ " x $\frac{1}{4}$ " rabbet. To do this, attach a wooden fence to your table saw rip fence, see Fig. 2. I also used a wooden extension on my miter gauge. The extension supports the piece and helps prevent chipout. Now set the rip fence to act as a stop and cut a rabbet on both ends of the end blocks (A), see Fig. 2.

Note: These rabbets (and the grooves that follow) must be cut into end grain on the end blocks (A).

CUTTING THE GROOVES. After the rabbets are cut, divide the space between the rabbets into six equal spaces (or the number of chisels in your set) with a $\frac{1}{4}$ " groove between them, see Fig. 3. Now move the table

saw fence so that it acts as a stop for your next cut. After cutting the first groove, turn the piece end for end and cut another groove before moving the fence. Repeat this procedure until all of the grooves are cut.

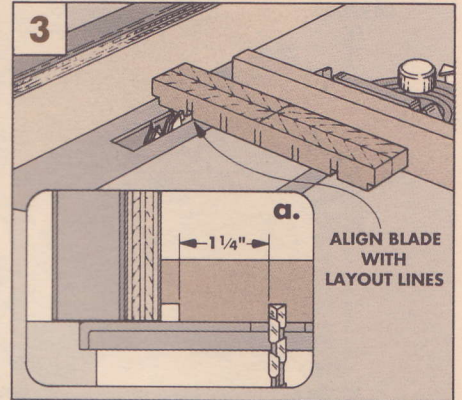
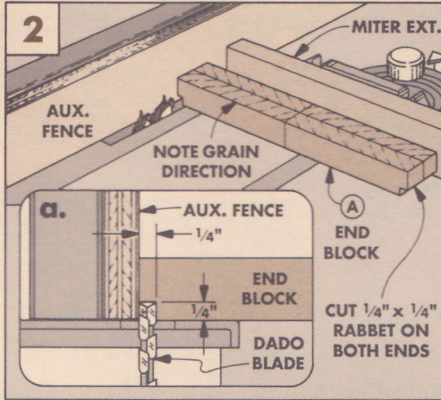

DIVIDERS & BOTTOM PANEL

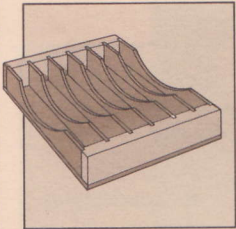

With the end blocks (A) completed you can begin work on the **case dividers (B)**. Start by ripping $\frac{1}{4}$ " stock for the dividers to width.

RIP TO WIDTH. To determine the width of the dividers, measure the *thickness* (height) of the end blocks (A) and rip the dividers to that width. (In my case that measurement was $1\frac{1}{2}$ ".)

DETERMINE THE LENGTH. After the pieces have been ripped to width, I cut all of the dividers to the correct length for my chisels.

To determine this length, measure your longest chisel and add $\frac{3}{4}$ ". (The extra $\frac{3}{4}$ " allows for the $\frac{1}{4}$ " grooves in the end blocks (A) and a $\frac{1}{4}$ " of clearance within the case.)

LAYING OUT THE ARC. After the dividers (B) have been cut to length, lay out a shallow arc to allow clearance to pick up the chisel.

Begin by laying out the arc on one of the dividers. To do this, mark points $1\frac{5}{8}$ " in from each end of the divider along the top edge, see Fig. 4.

To draw the arc, tape the divider to a scrap piece of plywood and drive a couple of nails alongside the two marks on the divider, see Fig. 4. Then bend a piece of posterboard inside the nails and adjust the apex of the arc so it's $\frac{1}{4}$ " from the opposite edge of the divider. Then draw the arc.

CUTTING THE ARC. Next stack all of the dividers with the arc on top and wrap the stack with masking tape, making sure that the edges and ends are flush, see Fig. 5. Now cut close to the layout line with the band saw, and then sand up to the line using a drum

sander or a sanding block.

ASSEMBLY. After the dividers have been sanded, fit and glue them into the grooves in the end blocks, see Fig. 6. (Make sure that this assembly is square and that it sits flat.)

BOTTOM PANEL. After the dividers (B) are glued into the end blocks (A), you can make the **bottom panel (C)**.

Start by edge-gluing enough $\frac{1}{4}$ "-thick stock to make the bottom panel, see Shop

Notes, page 12. The finished size of the bottom panel is the same as the outside dimensions of the tray that you just glued up, see Fig. 7. (Our divider tray measured $9\frac{1}{4}$ " x $12\frac{1}{2}$ ".)

Now glue the bottom panel (C) to the divider tray. Use glue sparingly to avoid squeeze out. Make sure the edges of the bottom panel (C) are flush with the sides of the tray dividers (B) and the end blocks (A).

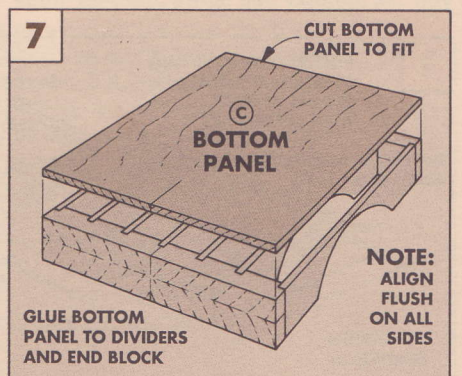
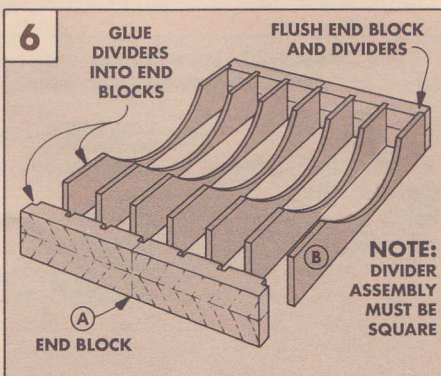
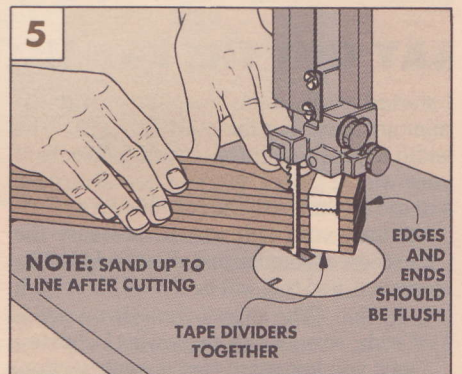
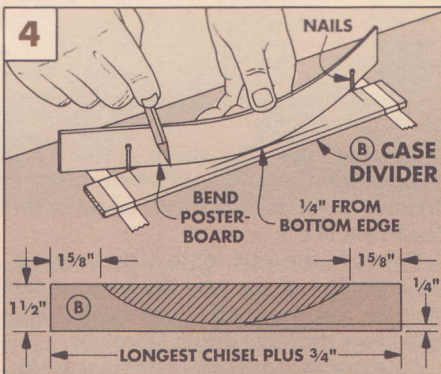

LID ASSEMBLY

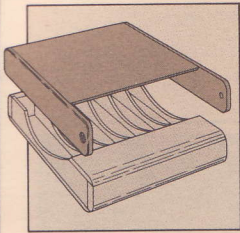

After the tray assembly is complete you can begin on the **lid panel (E)**. Start by gluing up enough stock to make a panel that's $\frac{1}{4}$ " wider and 1" longer than the tray. After it dries, rip the panel $\frac{1}{16}$ " wider than the tray.

ASSEMBLE THE POCKET. Next, to form the pocket and lid top, cut the panel into two parts, see Fig. 8. To determine the length of the pocket, measure from the end of the tray, to where the arc begins on the divider. Then add $\frac{1}{2}$ " to allow for trimming.

Now set your saw blade at 30° and cut a piece off the panel that's the length you just determined, see Fig. 8a.

Next, place the short piece on the case so the long beveled point is touching the arc. Now mark and trim the end flush, see Fig. 9.

LID SIDES. To make the **lid sides (F)**, start by measuring the thickness (height) of the case. Then rip two pieces of $\frac{1}{4}$ " stock to that measurement (2") and cut them to the same length as the case, see Fig. 9.

After the lid sides (F) are cut, fasten them to the tray with double-sided carpet tape.

HINGE SCREWS. With the sides in place you can drill the holes for the hinge screws. First, drill a $\frac{3}{8}$ " counterbore, $\frac{1}{16}$ " deep and

$\frac{1}{2}$ " from the bottom end, see Fig. 10. Then, drill a $\frac{1}{8}$ " pilot hole through the lid sides (F) and into the end blocks (A), see Fig. 10. Now remove the carpet tape and enlarge the hole in the lid sides (F) to $\frac{7}{32}$ ".

Before screwing the lid sides (F) to the case tray, place a $\frac{1}{32}$ " shim behind each lid side (F). Now tighten down a No. 12 round-head screw until the bottom of the screw slot is flush with the lid sides (F), see Fig. 10a.

ASSEMBLE THE LID. Next, fit the remaining part of the lid between the sides, and trim the end flush with the top of the case, see Fig. 9. Then glue the panel to the lid sides (F) only. When the glue is dry, file the screw heads flush, see Fig. 10a.

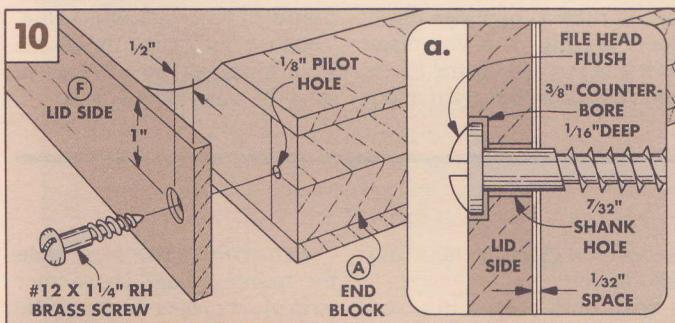
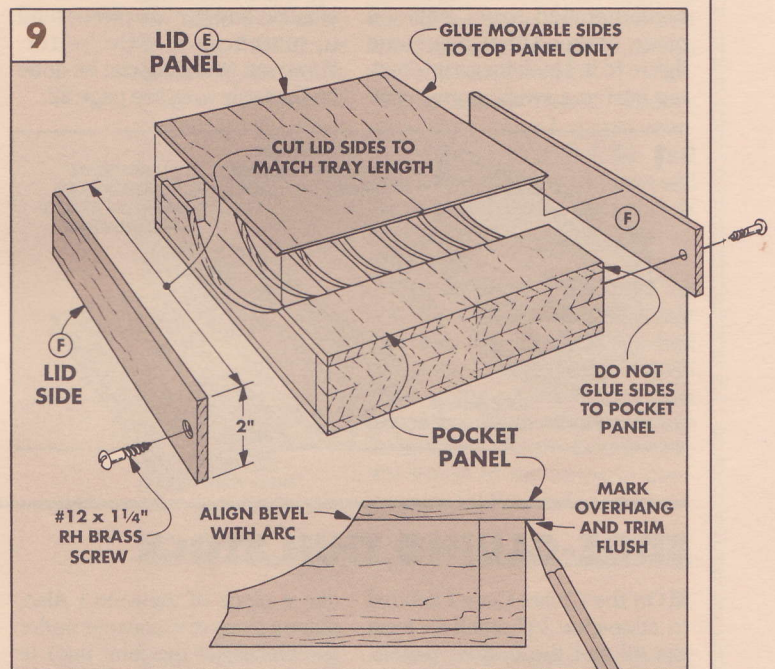
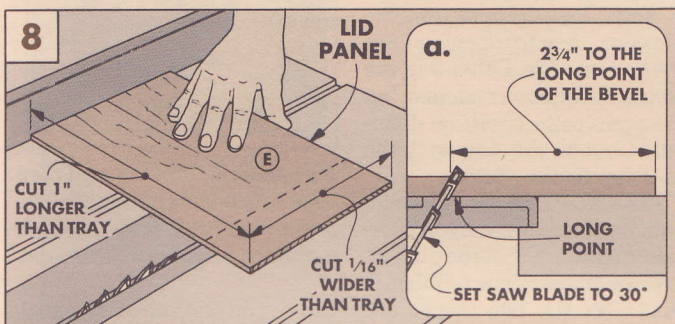

TOOL RESTS AND LID STIFFENER

Once the lid is completed, round over the sides ($\frac{1}{8}$ " round-over) and ends ($\frac{1}{2}$ " round-over), refer to Fig. 12. Then you can begin on the **chisel rests (D)** and **lid stiffener (G)**.

ROUTING THE EDGE. Using the cut-off left over from making the end blocks (A) (refer

to Fig. 1), use a $\frac{3}{8}$ " round-over bit and rout a bullnose on both ends, see Fig. 11a.

CUT TO FIT. After the bullnoses are complete, cut off two $\frac{1}{2}$ "-long pieces, see Fig. 11. Now, cut the chisel rests (D) to fit between the case dividers (B), and cut the lid

stiffener (G) to fit between the lid sides (F), see Fig. 12. Finally, glue the pieces in as shown in the Cross Section on page 9.

FINGER RECESS. The last step is to file a $\frac{3}{4}$ "-wide finger recess in the bottom end to make a lip for opening the lid, see Fig. 12.

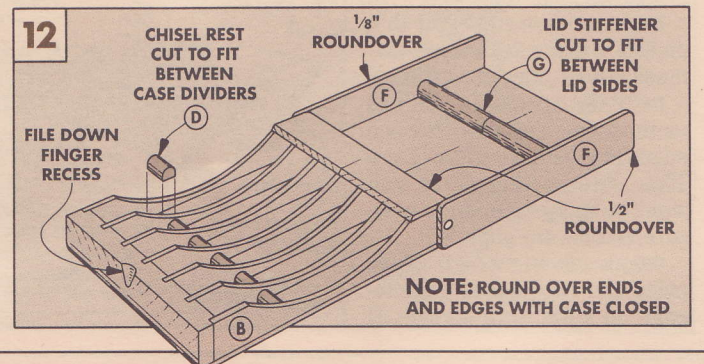
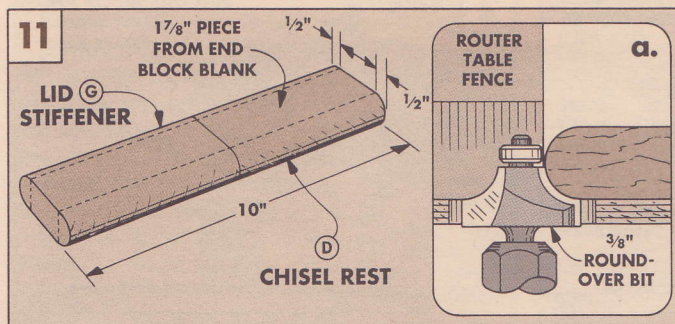

Shop Notes

BOOK MATCHING

■ When making the Chisel Case on page 8, I used a technique called *book matching* to create the mirror image grain pattern on the lid. Book matching refers to how a piece of stock is cut and glued back together.

GRAIN PATTERN. To create a book-matched panel, select a piece of wood that has some figure to it. I look for an interesting burl or a swirling grain pat-

tern. Make sure that the pattern goes *all* the way through the piece. (If it doesn't go through, it may not book match.)

RESAW PIECE. Now, resaw the piece into two parts of equal thickness. I prefer to resaw on the band saw because the kerf is smaller, and the two pieces tend to match up a little better. However, resawing can be done on the table saw, see page 22.

OPEN THE BOOK. After resawing, put the two halves back together as if the piece had never been cut. Now stand them on edge and open the two pieces as if you were opening a book. The spine of this "book" becomes the matched joint.

Note: Open the book from the top edge, then try opening from the bottom edge. Either way, the pieces will be book matched, but the grain pattern *will* be different. Choose the one with the most interesting pattern.

PLANING PROBLEM. Although matched lumber gives you interesting patterns, it can be difficult to plane smooth. The problem is that after the two pieces are glued together, the grain of the pieces runs in opposite directions, see Fig. 1. If you plane both pieces of the panel in the same direction, the grain might

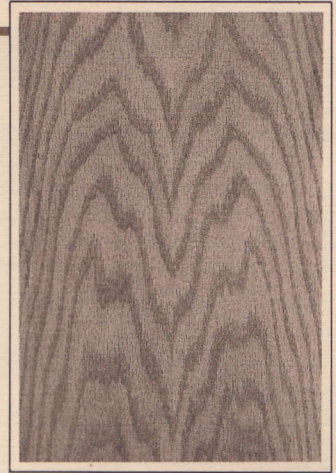

By resawing lumber, and then edge-joining the pieces back together in a book match, you get a pattern with a mirror image.

tear out on one half of the panel. The solution is to plane each piece *before* you edge-gue. Then carefully align the pieces when gluing so you only have to sand the panel after it dries.

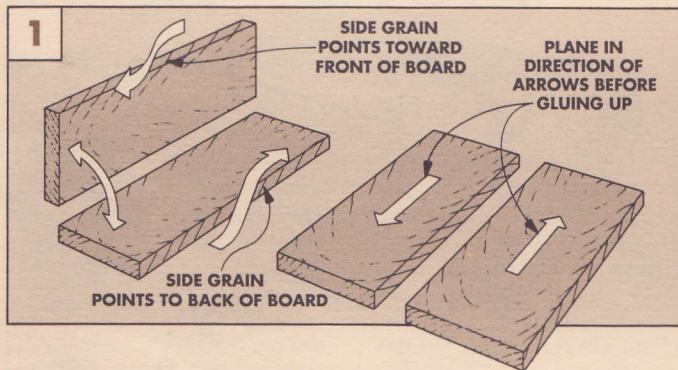

EDGE-GLUING THIN STOCK

■ On the Chisel Case I needed to edge-gue $\frac{1}{4}$ " stock to form the lid and the bottom panels. Edge-gluing thin stock with pipe clamps can be a problem.

As you tighten the clamp, the pressure is applied in line with the screw on the clamp head, which is usually centered about $\frac{3}{4}$ " above the pipe. This puts uneven pressure on the joint and the pieces won't lie flat. If you apply too much pressure the pieces might spring apart.

So, in order to edge-gue thin pieces, I use a technique that musical instrument makers use.

PREPARE STOCK. To use this method, first make sure the two edges fit together *without* gaps. This is important since you won't be applying enough pressure to close any gaps.

WORK ON PLYWOOD. Now, place the two pieces edge-to-edge on a flat work surface. (I

use a piece of plywood.) Also, place a piece of wax paper under the pieces (at the joint line) to prevent them from sticking.

Next, drive several small nails or brads, into the plywood, along the edge of *one* of the pieces.

SPACER. After the nails are in place, slide a $\frac{1}{2}$ "-thick spacer under the joint line. Center the spacer on the joint and make sure the bottom edges of the two

pieces to be glued are *touching*, see Fig. 1.

With both pieces in place, drive several nails into the plywood along the edge of the other piece, see Fig. 1.

GLUE THE JOINT. When the nails are in place on both edges, tilt one of the panels up and spread a *light* film of glue along the inside edge. Then gently set the piece back into position.

WEIGH DOWN TOP. Next, slide the spacer out and lay another strip of wax paper on top of the joint line. Now lay a board on top of the wax paper and stack a heavy object (I used a brick) on top of the board.

Make sure the two pieces are laying flat, and let the glue dry. After the glue dries, remove the nails from one side before taking the panel up.

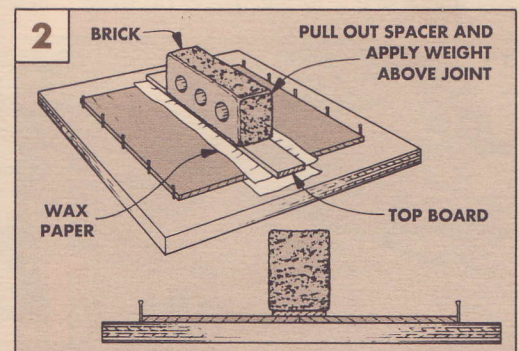
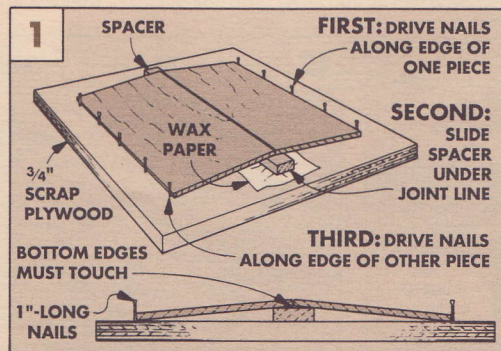

FOR YOUR CONVENIENCE

We want to provide the best service possible for your subscription. Please feel free to use the order form (on the back side of this page) and the postage-free envelope to renew your subscription, order a gift subscription, or change your address. Also feel free to pass the order form and envelope along to a friend who might enjoy *Woodsmith*.

If you have any questions you'd like to ask, or suggestions for the articles you'd like to see in *Woodsmith*, or if you just want to drop us a line, go ahead and use the postage-free envelope.

PROBLEMS?

If you're having a problem with your subscription, check the box below that applies, or jot down a note explaining the problem. We'll do everything we can to correct it.

- My *Woodsmith* Issue No. _____ was damaged in the mail, please send a replacement copy.
(Write your name and address below.)
- My *Woodsmith* Issue No. _____ has missing pages or duplicate pages, please send a replacement copy.
(Write your name and address below.)
- I am receiving duplicate issues of *Woodsmith*.
(Write your name and address below.)
- Please withdraw my name from the rental list.
(Note: From time to time we rent the *Woodsmith* subscriber list to qualified woodworking companies who send out catalogs or information on woodworking tools and supplies. If you *do not* want to receive this type of information, please check the box and write your name and address below.)

Account Number (shown on top line of mailing label):

--	--	--	--	--	--	--	--	--	--	--	--	--	--	--	--	--	--	--	--

Your Name _____ Please Print Clearly

Address _____

City _____ State _____ ZIP _____

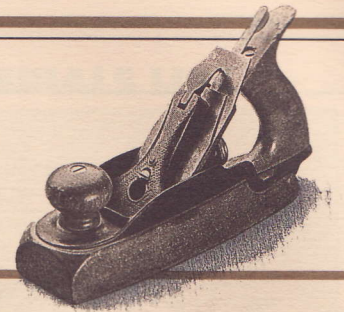

stop blocks (I use mite) in front and in workpiece. Also, fit a in spacer blocks be-workpiece and the s.

THE JIG. After the jig is can begin planing. I the plane held at an he heel of the plane r one of the guide Fig. 2. Continue to the heel of the plane

“bottoms out” on the right guide strip and the toe bottoms out on the left guide strip.

If the workpiece is so wide that the plane can't bridge across both guide strips, that's okay. As long as you start with the heel over one guide strip, the toe of the plane will finally rest on the far guide strip as you work across the piece.

ONE MORE THING. There's one other thing I should mention here. I said that the final thickness of the workpiece will be the same as the thickness of the guide strips. That's not exactly true.

Since the cutting edge of the blade sticks out slightly below the sole of the plane, the finished thickness of your workpiece will actually be a hair thinner than the strips. If your thickness has to be *exact*, slightly increase the thickness of the strips to compensate for the blade depth.

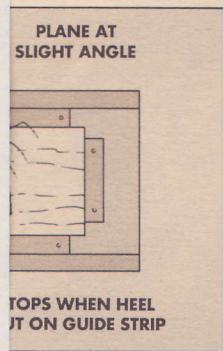

THE JIG. After building you're ready to plane. tacking the workpiece e jig base with double-t tape, see Fig. 2. Next, mount any *flat* in the router. After g, I found a 3/4" or 1/2"- bit worked the best.

MULTIPLE PASSES. Set the bit about 1/8" deep and rout the workpiece *with* the grain. (Routing across the grain may create swirls on the face.) Then make another pass to “plane” the stock to final thickness. If there are any swirls left on the surface, I use a scraper to clean them off.

next, to raise the router up on the workpiece, I glued rails along the edges of the base. Cut the rails 1/4" wider (higher) than the thickness of the workpiece.

SLIDING WING. After making the base, I cut out a wing to replace the plastic base on the router. To make the wing, rip a piece of 1/4" Masonite 2" wider than the router's plastic base. As

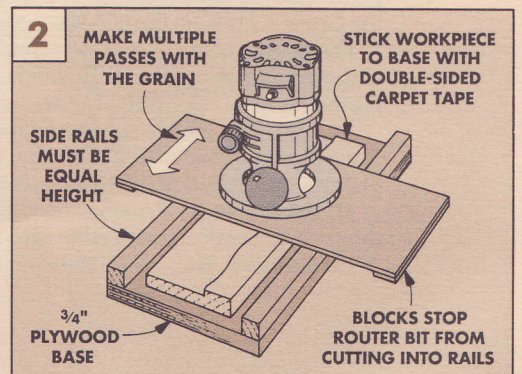
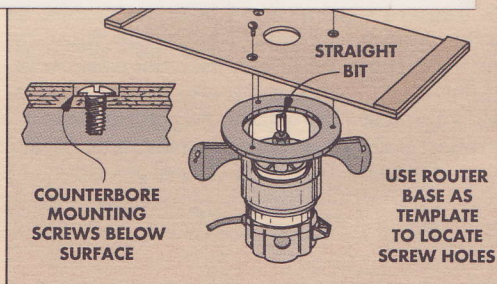

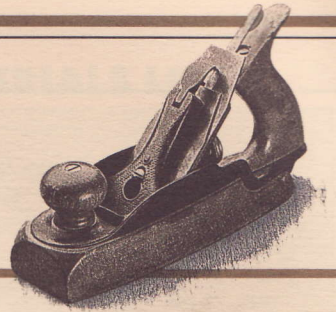

HAND PLANING THIN STOCK

■ If you resaw stock on a band saw, you're faced with the task of smoothing the rough-sawn surface. On small pieces I use a hand plane. But it's difficult to plane a *consistent* thickness across the entire piece.

I've found it's worth the time to make a jig that helps stop the plane at the correct thickness. (Note: First, I resaw the workpiece about $\frac{1}{16}$ " over the final thickness, see page 22.)

MAKING THE JIG. To make the jig, start by cutting a plywood base, see Fig. 1. Then rip two guide strips to the final thickness you want for the workpiece. Now place the resawn workpiece on the base and tack the strips about 1" from each edge of the workpiece. (To keep from damaging the plane, set the brads below the surface.)

Next, to keep the workpiece from moving while planing, tack

down thin stop blocks (I use $\frac{1}{8}$ " Masonite) in front and in back of the workpiece. Also, fit a couple of thin spacer blocks between the workpiece and the guide strips.

USING THE JIG. After the jig is built, you can begin planing. I start with the plane held at an angle so the heel of the plane hangs over one of the guide strips, see Fig. 2. Continue to plane until the heel of the plane

"bottoms out" on the right guide strip and the toe bottoms out on the left guide strip.

If the workpiece is so wide that the plane can't bridge across both guide strips, that's okay. As long as you start with the heel over one guide strip, the toe of the plane will finally rest on the far guide strip as you work across the piece.

ONE MORE THING. There's one other thing I should mention here. I said that the final thickness of the workpiece will be the same as the thickness of the guide strips. That's not exactly true.

Since the cutting edge of the blade sticks out slightly below the sole of the plane, the finished thickness of your workpiece will actually be a hair thinner than the strips. If your thickness has to be *exact*, slightly increase the thickness of the strips to compensate for the blade depth.

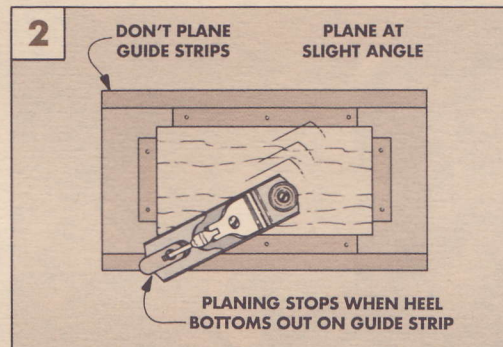
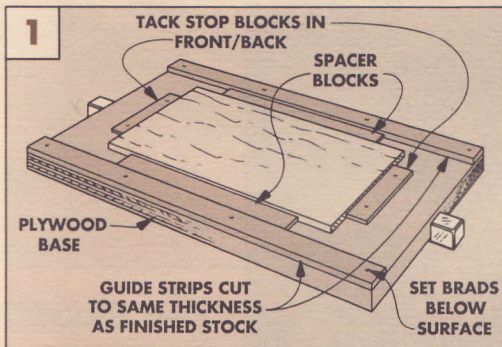

PLANING WITH A ROUTER

■ Besides planing thin stock with a hand plane, I've also used a router, making repeat passes.

To do this, I made a two-part jig, see Fig. 2. The first part is a base to hold the workpiece. The second part is a wing attached to the router that slides on the base.

BASE. To make the base, cut a rectangle from $\frac{3}{4}$ " plywood a little longer than the length of the workpiece, and about 3" wider than your workpiece.

Next, to raise the router up off the workpiece, I glued rails along the edges of the base. Cut the rails $\frac{1}{4}$ " wider (higher) than the thickness of the workpiece.

SLIDING WING. After making the base, I cut out a wing to replace the plastic base on the router. To make the wing, rip a piece of $\frac{1}{4}$ " Masonite 2" wider than the router's plastic base. As

for the length, cut it twice as long as the *width* of the *jig's* base.

Now screw the wing to the router using the original base plate as a drilling guide.

Also, to keep the bit from routing into the rails, I glued stop blocks to the bottom of the wing near the ends, see Fig. 1.

USING THE JIG. After building the jig, you're ready to plane. Start by sticking the workpiece down on the jig base with double-sided carpet tape, see Fig. 2.

THE BIT. Next, mount any *flat-bottom* bit in the router. After some testing, I found a $\frac{3}{4}$ " or $\frac{1}{2}$ "-dia. straight bit worked the best.

MULTIPLE PASSES. Set the bit about $\frac{1}{8}$ " deep and rout the workpiece *with* the grain. (Routing across the grain may create swirls on the face.) Then make another pass to "plane" the stock to final thickness. If there are any swirls left on the surface, I use a scraper to clean them off.

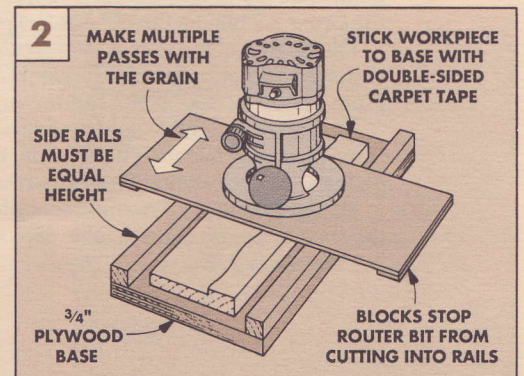
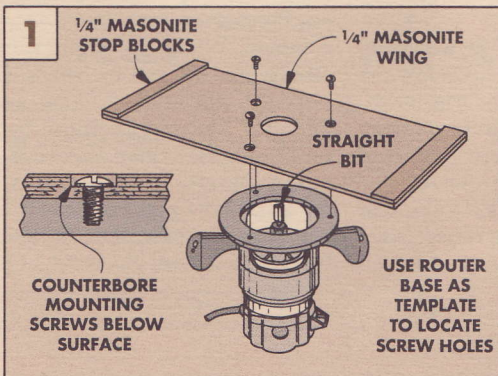

Toolbox

How do you make a toolbox that's both strong and lightweight? Our solution was to use thin maple and join it with box joints. We also added a unique laminated handle on top.

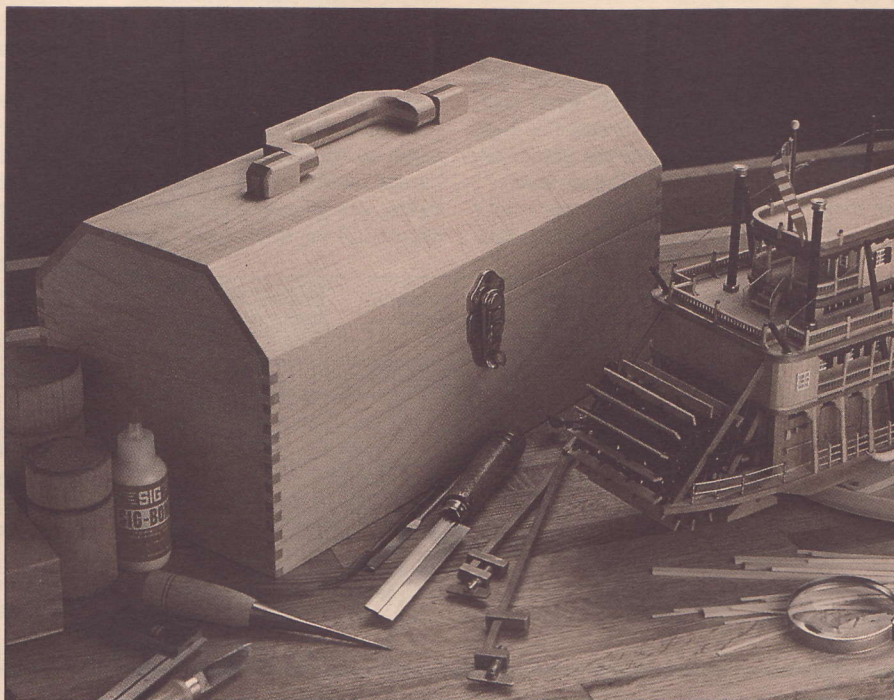

There are two main considerations in designing a toolbox: strength and weight. It has to be strong enough to stand up to heavy use, but light enough so it isn't a burden to carry around.

REINFORCEMENTS. The solution was to build the toolbox from thin stock ($\frac{1}{4}$ "), but reinforce the weak spots. For example, the top panel of the lid is made from $\frac{1}{4}$ " stock that's backed with another piece of $\frac{1}{4}$ " stock. This backing locks the angled lid pieces together and provides a $\frac{1}{2}$ " base to attach the handle, see the Cross Section on the opposite page.

The bottom of the case is cut from $\frac{1}{4}$ " plywood and mounted into $\frac{1}{8}$ " grooves. To keep the lip below the grooves from breaking out, I added angled trim strips.

JOINERY. I decided to use box joints for this project. If the pins and slots match perfectly, there's plenty of gluing surfaces and that creates a strong joint.

The box joints are also small enough ($\frac{1}{4}$ " x $\frac{1}{4}$ ") that they can be cut on either a table saw or a router table. (In *Woodsmith* No. 42 we showed how to make an

adjustable box joint jig for either the table saw or the router table.)

HANDLE. The handle is probably the most unusual part of this project. The easy way to make a handle is to cut it out of a piece of $\frac{3}{4}$ " stock. But there would be weak spots at the upper corners where the grain cuts directly across the corner.

Instead, I laminated the handle from three pieces of $\frac{1}{4}$ " stock. The grain on the middle piece runs at right angles to the face pieces. Like plywood, this strengthens the piece in both directions.

WOOD. I built the toolbox from hard maple. It's strong and will last for years. (Thin lumber may be difficult to obtain, see *Talking Shop and Sources*, pages 23 and 24.) Maple can chip out when planing. (For tips on planing, see *Shop Notes*, page 12.) Poplar or red gum would also be good choices. They're not as strong as maple, but lighter and easier to plane.

FINISH. For maximum durability I decided to apply two coats of semi-gloss polyurethane to the toolbox.

EXPLODED VIEW

OVERALL DIMENSIONS:
8 1/4"H x 16"L x 8"D

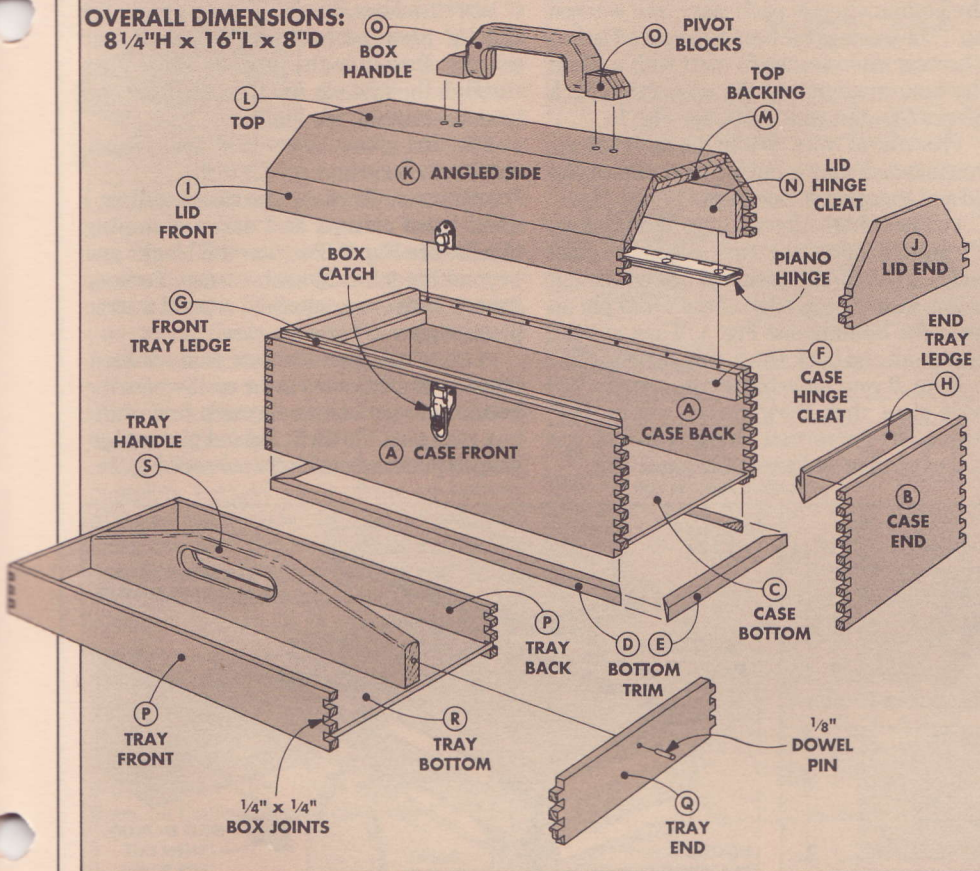

MATERIALS LIST

CASE

A	Front/Back (2)	1/4 x 4 1/4 - 16
B	Ends (2)	1/4 x 4 1/4 - 8
C	Bottom (1)*	1/4 x 7 3/4 x 15 3/4
D	Btm. Fr/Bk Trim (2)	1/4 x 1/4 - 15 1/2
E	Btm. End Trim (2)	1/4 x 1/4 - 7 1/4
F	Hinge Cleat (1)	1/4 x 1 - 15 1/2
G	Fr. Tray Ledge (1)	1/2 x 1 1/4 - 15 1/2
H	End Tray Ledges (2)	1/2 x 1 1/4 - 7 1/4

LID

I	Front/Back (2)	1/4 x 1 3/8 - 16
J	Ends (2)	1/4 x 3 - 8
K	Angled Sides (2)	1/4 x 3 - 16
L	Top (1)	1/4 x 4 1/4 - 16
M	Top Backing (1)	1/4 x 4 1/2 - 15 1/2
N	Hinge Cleat (1)	1/4 x 1 3/4 - 15 1/2
O	Box Handle (1)	1/4 x 3 - 6 (3 pcs.)

TRAY

P	Front/Back (2)	1/4 x 1 3/4 - 14 15/16
Q	Ends (2)	1/4 x 1 3/4 - 6 15/16
R	Bottom (1)*	1/4 x 6 3/4 x 14 11/16
S	Handle (1)	1/2 x 2 1/2 - 14 7/16

* These pieces are 1/4" plywood.

CUTTING DIAGRAM

1/4" x 5" - 33" (1.15 Sq. Ft. Each)

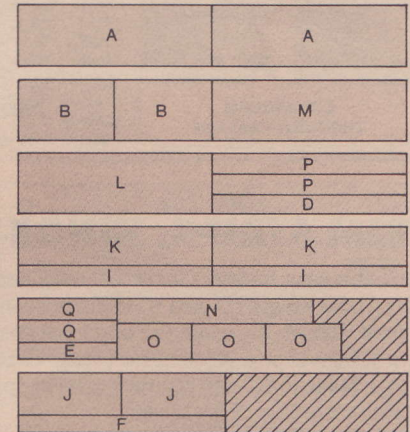

1/2" x 3" - 33" (.7 Sq. Ft.)



ALSO REQUIRED:
ONE 24" x 24" PIECE OF 1/4" PLYWOOD
FOR CASE AND TRAY BOTTOMS (C, R)

SUPPLIES

LUMBER

- 7 Square ft. 1/4" solid maple
- 0.7 Square ft. 1/2" solid maple
- 24" x 24" piece 1/4" maple or birch ply.

HARDWARE*

- 1 Brass piano hinge (1 1/16" x 13")
- 1 Brass box catch with screws
- 6 No. 6 x 3/4" roundhead woodscrews

* See page 24 for kit information

FINISH

- Varnish: Satin polyurethane

CROSS SECTION

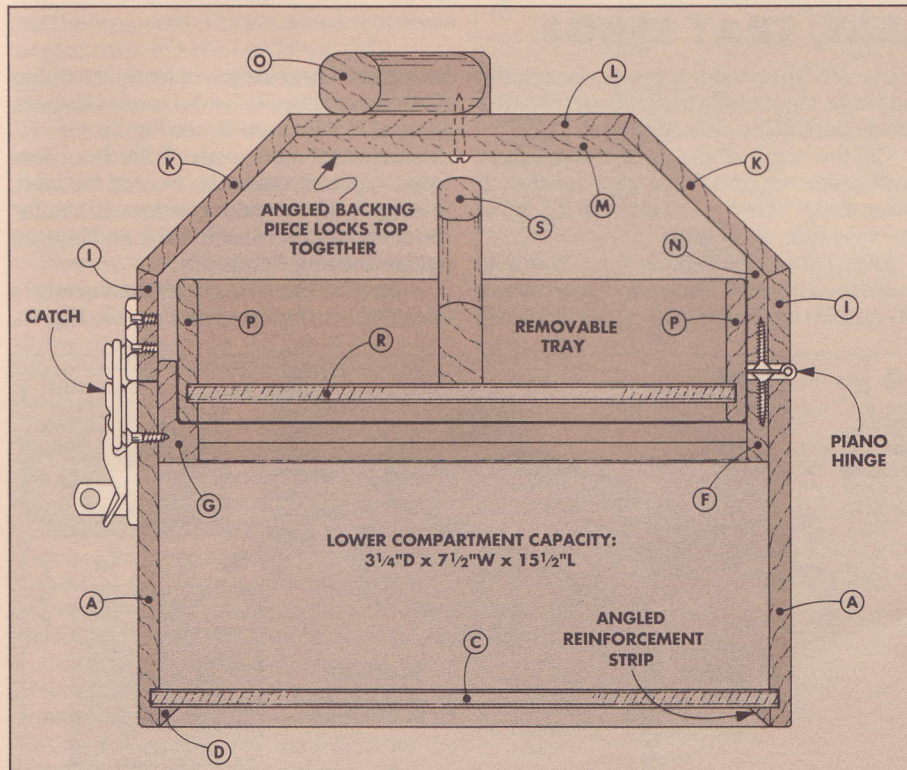

CASE

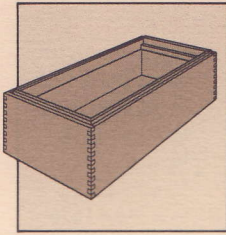

I began work on the toolbox by making the case. Start by cutting a **case front and back (both A)** and two **ends (B)** from $\frac{1}{4}$ " stock to a rough width of 5", see Fig. 1. Then cut

the front and back pieces (A) 16" long and the ends (B) 8" long.

Procedural Note: While you're set up, you can also cut the lid pieces so they're the exact same lengths, see opposite page.

BOX JOINTS. After the pieces are cut to size, you can cut $\frac{1}{4}$ " box joints on the ends of all four pieces, see Fig. 1.

When cutting the box joints I started at

the bottom edge of each piece and worked up. (The waste at the top will be cut off later.) The case end pieces (B) start with a pin at the bottom edge and the case front/back pieces (A) start with a slot, see Fig. 1a.

Procedural Note: While the jig is set up, you may also want to cut the box joints on the lid and tray pieces (see pages 17 and 18).

CUT TO WIDTH. After cutting the box joints, I trimmed down the case pieces to final width. First rip the case end (B) so the cut aligns with the top edge of the *ninth* pin up from the bottom, see Fig. 1. Then cut the case front and back (A) to this same width.

Note: If your dado blade cuts *exactly* $\frac{1}{4}$ "-wide slots, then these pieces will be $4\frac{1}{4}$ " wide. The important thing is to cut the pieces so they end with a full pin or slot.

BOTTOM. Next, cut an $\frac{1}{8}$ "-deep groove for the $\frac{1}{4}$ " plywood **bottom (C)** on all four pieces. Position the groove so it cuts through the first pin (on the case front) up from the bottom, see Fig. 1.

After the groove is cut in all four pieces, cut the plywood bottom (C) to fit.

ASSEMBLY. To clamp the case together, I used band clamps and scrap clamping blocks, see Fig. 2. Position the blocks just beyond the joints at each corner. To keep the top of the case square, I slipped a scrap piece of plywood into the case.

PLUG HOLE. After the case is assembled, there's still a little void in the ends where the bottom groove comes through one of the box joint pins. To fill it, I glued in a wedge-shaped plug and cut it off flush, see Fig. 2a.

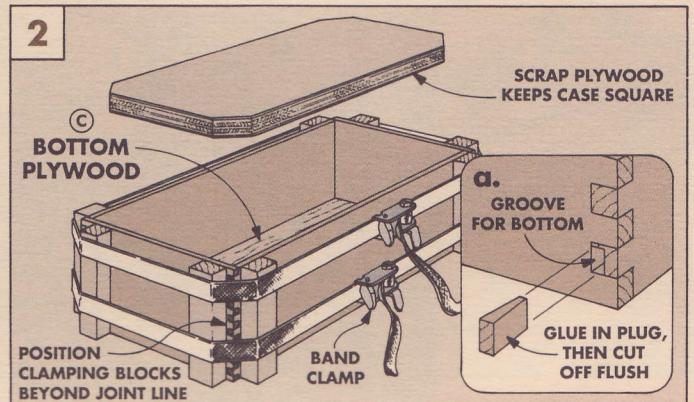
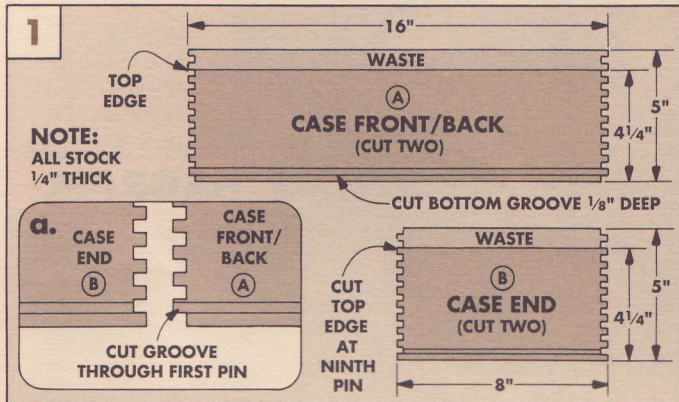

TRIM STRIPS, HINGE CLEAT, TRAY LEDGE

After the case is dry, I turned it over and added **trim strips (D and E)** to the bottom.

TRIM STRIPS. To make the angled strips, rip a 45° bevel on a piece of $\frac{1}{4}$ " stock. Then set the blade to 90° and rip the angled strips off the waste side of the blade.

Next, miter the strips to length and glue them in place, see Fig. 3.

HINGE CLEAT. After the trim is in place, I turned the case over and started to work on

the inside. To provide a screw surface for the lid hinge, I mounted a **hinge cleat (F)** to the inside back of the case, see Fig. 4.

Cut the hinge cleat 1" wide and to length to fit inside the case. Then glue the cleat in place so the top edge is flush with the top of the case back, see Fig. 4a.

TRAY LEDGE. To support the removable tool tray, I glued 1"-wide **tray ledge strips (G and H)** inside the case on the front and

both ends. These strips are made by cutting a $\frac{1}{4}$ "-deep rabbet $\frac{3}{4}$ " wide on one edge of a piece of $\frac{1}{2}$ "-thick stock, see Fig. 4b.

Then miter both ends of the front tray ledge (G) to fit inside the front of the case, see Fig. 4. On the end tray ledges (H), miter the front end, but let the back end butt up against the hinge cleat (F).

Now, glue the strips in so the top edges are $\frac{1}{4}$ " above the top of the case, see Fig. 4b.

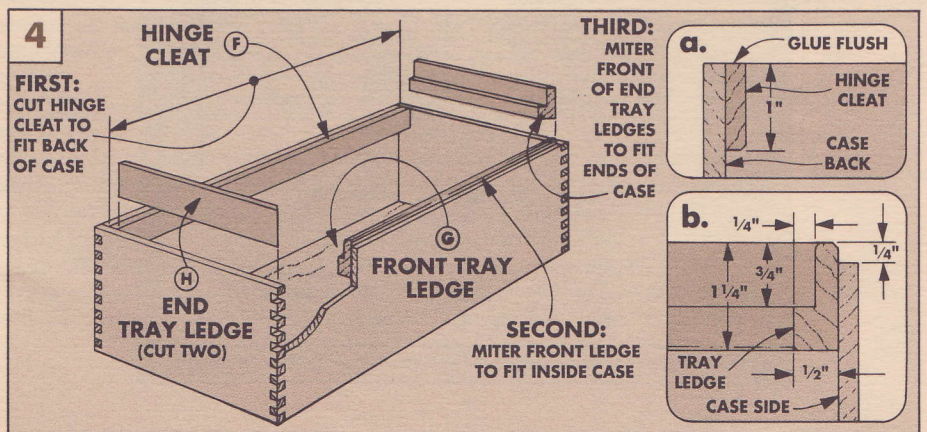
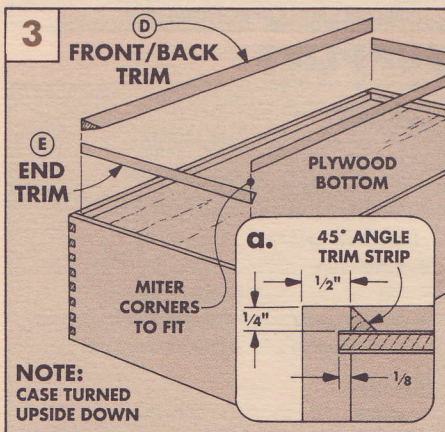

LID FRAME

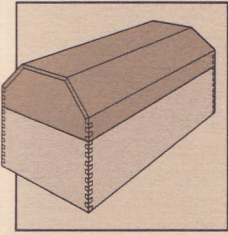

The basic case is complete at this point. Next, you can build the lid. Begin by cutting the **lid front and back pieces (I)** 1 3/4" wide and the same length as the case (16"), see Fig. 5. Then cut two **lid ends (J)** 3" wide and to length to match the case (8").

BOX JOINTS. With the pieces cut to size, you can cut the box joints. Once again, start from the bottom edges, see Fig. 5.

Note: Only *two* slots are cut in the front/back pieces so there's room to bevel the top edges later, refer to Fig. 6.

CUT OFF ANGLES. After the box joints are complete, cut a 45° angle off the top corners of the end pieces (J), see Fig. 5. To do this, make the cut so the angle aligns with the top outside corner of the second pin, see Fig. 5a.

CUTOFF FRONT/BACK. Next, dry assemble the lid pieces. Where the angled corner you just cut on the end piece meets the front piece, make a mark, see Fig. 6. Then rip the front/back pieces at 22 1/2° so the *short* point of the angle ends at the mark.

ASSEMBLY. Now glue these four lid pieces together. To hold them square, I placed them on the assembled case, see Fig. 7.

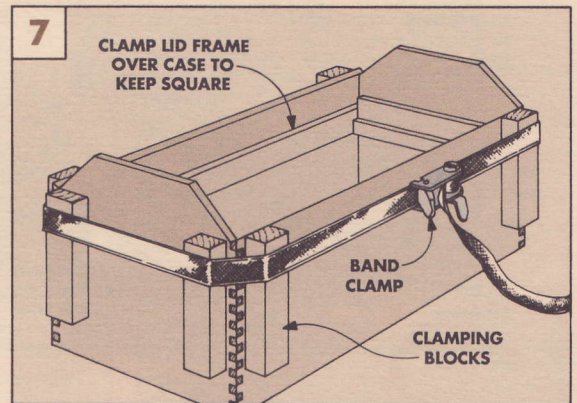
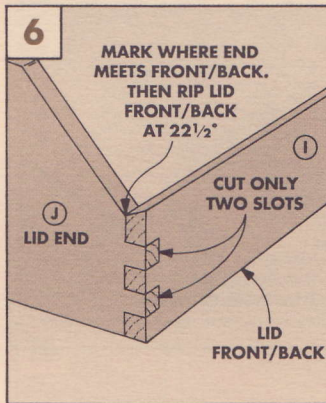
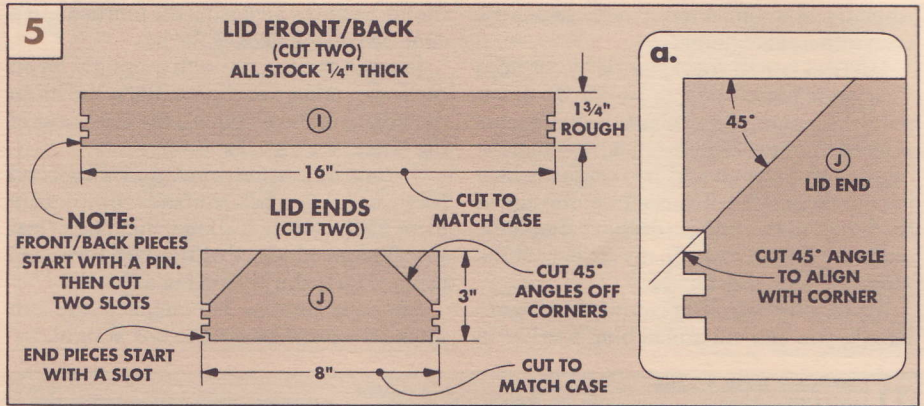

LID TOP

Once the lid frame assembly is dry, you can cut the top pieces. The top is made out of two angled sides (K) and one lid top (L).

ANGLED SIDES. I started by cutting the two **angled sides (K)**, see Fig. 8. Rip one edge of each piece at a 22 1/2° angle to a rough width of 3 1/2". To determine the final width, hold the piece in place and mark the point where the angled corner on the lid end (J) meets the angled side piece (K).

Now rip the pieces to width (at 22 1/2°) on the pencil mark and cut them to length.

TOP. Once the angled pieces are glued down, the **top piece (L)** fits in like a key-stone, see Fig. 9. First cut one edge at 22 1/2°. Then sneak up on the other edge until it fits.

BACKING. Next, I reinforced the top with a **backing piece (M)**, see Fig. 10. To make this piece, first cut it to length to fit inside the lid. Then rip the edges at 45° and glue it in.

HINGE CLEAT. To provide a screwing surface for the hinge, I mounted a **hinge cleat (N)** on the back inside of the lid, see Fig. 10. Rip one edge at 45°, and cut the other edge flush with the bottom of the lid, see Fig. 10a.

CHAMFER. With the cleat glued in, rout a chamfer around the *inside* edge of the lid front and ends to make the lid fit easier on the case. You may also have to bevel the outside of the tray ledges, refer to Fig. 4b.

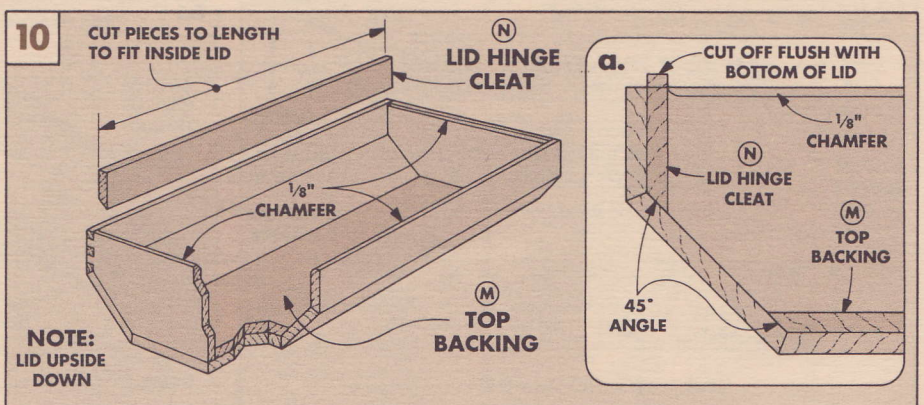
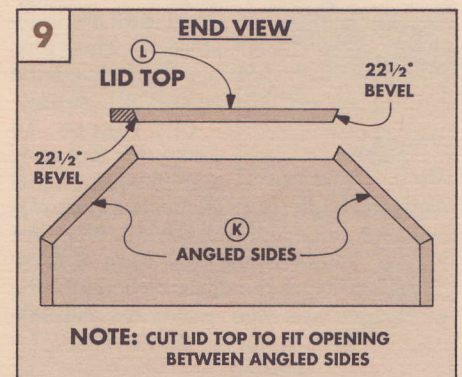
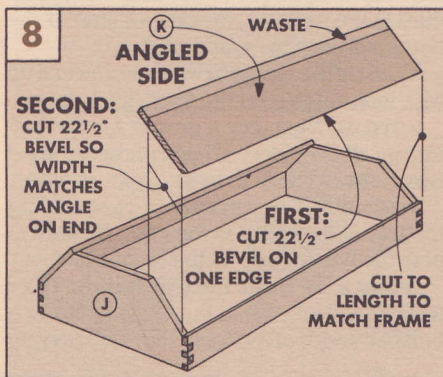

HINGE

After the lid is completed, it's attached to the case with a piano hinge.

CUTTING THE HINGE. I started by cutting a $1\frac{1}{16}$ "-wide piano hinge to length. To determine the length, three things should be considered: the length must be shorter than the case; both ends should be cut at knuckle joint lines; and the distance from the end of the hinge to the first screw hole should be uniform on both ends. In my case, I cut the hinge 13" long, see Fig. 11.

HINGE MORTISE. After cutting the hinge to length, you can cut a matching mortise in

the lid. Begin by laying out the mortise so it's centered on the back of the lid.

I routed the mortise with a straight bit on the router table, see Fig. 11. Raise the bit so the height of the bit equals the thickness of the hinge, see Fig. 11a.

To route the mortise, move the lid back and forth over the bit routing completely through the lid back (I) and the hinge cleat (N). I stopped short of the end lines and cleaned up to the lines using a chisel.

After the mortise is complete, you can mount the piano hinge, see box at right.

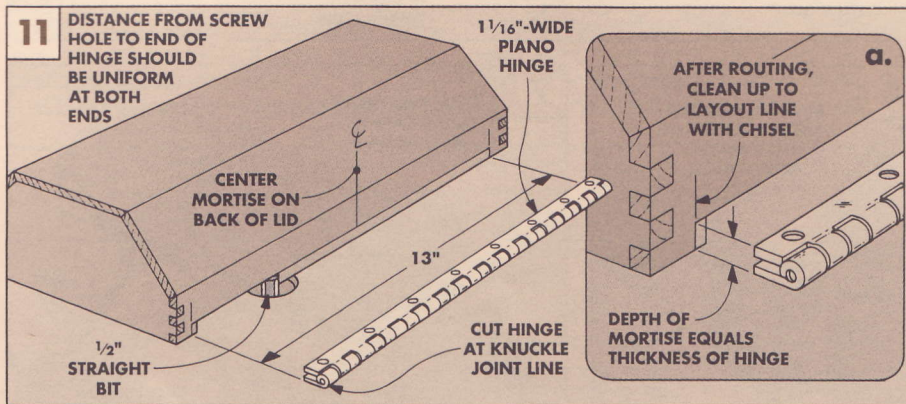

HINGE MOUNTING

To mount the hinge, I started by screwing one hinge leaf to the mortise in the lid.

Then, stick a narrow strip of double-sided carpet tape on the top back edge of the case. Now, set the lid on top of the case so it's in the closed position.

Next, carefully open the lid a little ways, reach inside, and press the hinge leaf down tight against the carpet tape. Then open the lid all the way and put a block of wood under the lid to support it. Now drill holes for the hinge screws by drilling through the holes in the hinge leaf and right on through the carpet tape, see drawing. Finally, remove the tape and screw the leaf down tight.

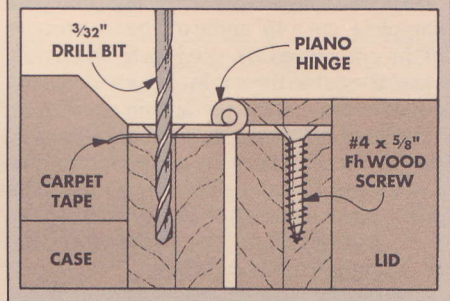

TRAY

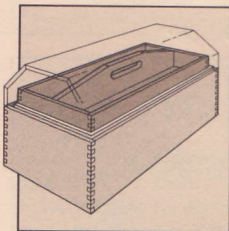

Sometimes it's handy to just carry a tray filled with tools instead of a whole toolbox. So I included a removable tool tray.

CUT PIECES. To make the tool tray, start by cutting a tray

front and back (both P) and two ends (Q) from $\frac{1}{4}$ " stock to a rough width of 2", see Fig. 12. To determine the length of these pieces, measure the distance between the tray edges inside the toolbox and then subtract $\frac{1}{16}$ " (so the tray fits comfortably).

BOX JOINTS. After the pieces are cut to size, you can cut the box joints. The procedure is the same as the case — start at the bottom of each piece and work up.

Then rip the pieces to width so you end up with four full pins on the front/back pieces.

BOTTOM. Next, cut a groove for the bottom on all the pieces. Then cut the plywood tray bottom (R) to fit between the grooves.

ASSEMBLY. The procedure for assembling the tray is the same as the case. Be sure to plug the holes made by the bottom groove.

HANDLE. To make the tray handle (S), I used $\frac{1}{2}$ " stock. First, cut the handle to a finished width of $2\frac{1}{2}$ ", see Fig. 12. Then cut

it to length to fit inside the tray.

To form the grip, first drill two 1" holes $1\frac{1}{2}$ " down from the top edge, see Fig. 12. Then cut between the holes with a sabre saw. Now, cut angled sections out of the top corners of the handle, see Fig. 12. Then round over the inside of the grip and the top edges with a $\frac{1}{4}$ " round-over bit, see Fig. 13a.

ATTACH HANDLE. After the edges are rounded, I glued the handle to the inside bottom of the tray, see Fig. 13. To strengthen the joint, drill a $\frac{1}{8}$ " hole through the end of the tray and into the handle, see Fig. 13b. Then glue a short length of $\frac{1}{8}$ " dowel into the hole and trim it flush.

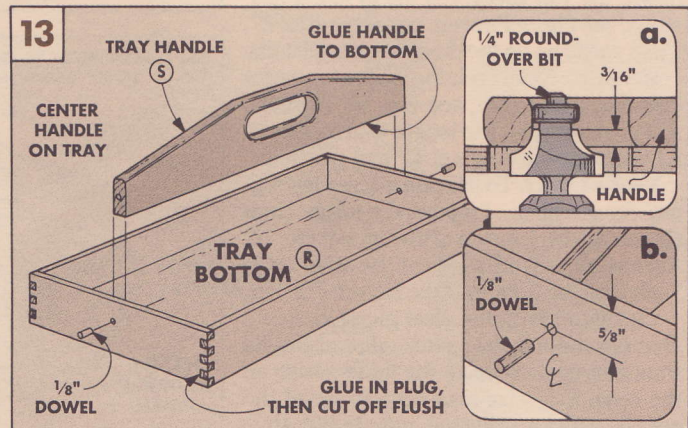
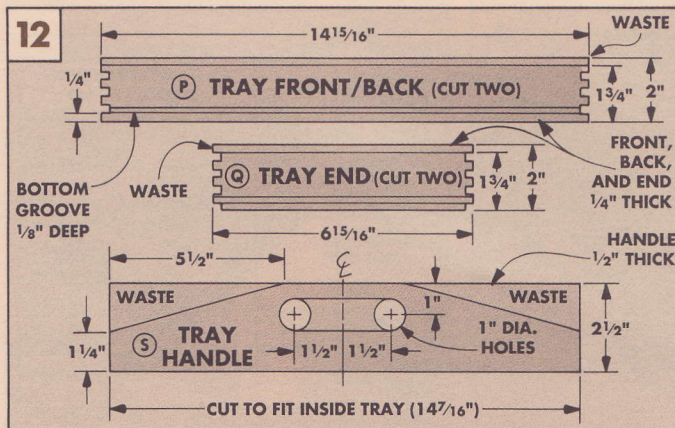

HANDLE

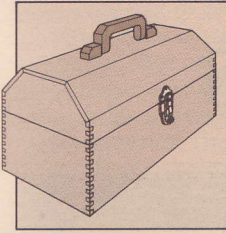

The last part to make is the **handle (O)** and the two blocks that hold the handle to the lid.

HANDLE BLANK. Start by laminating a blank from three pieces of 1/4" stock,

see Fig. 14. Cut the three pieces 3" wide and 6" long. Then cut one of the pieces in half. Now turn the two half pieces so the grain runs at right angles to the 6"-long pieces and "sandwich" (glue) the half pieces between the long pieces.

After the glue dries, rip the blank down to 2" wide for the handle and save the waste piece for the pivot blocks. Before cutting the shape of the handle, I trimmed the blank to 5 1/2" long and rounded over the bottom edges with a 3/8" round-over bit, see Fig. 15.

INSIDE CUTOUT. Next, to form the inside corners of the handle, drill two 3/4"-dia. holes, 1 1/8" from each end, see Fig. 15. Then lay out the inside edges of the handle.

Before cutting out the handle, I drilled 5/32"-dia. holes in the ends of the handle to hold pivot pins, see Fig. 15a.

CUT OUT SHAPE. Next, cut out the inside edges of the handle with a band saw, see Fig. 16. To finish the shape, trim 45° angles off the top corners.

ROUND OVER EDGES. To make the handle more comfortable to grip, I rounded over the top edge and the inside edges, see Fig. 17.

PIVOT BLOCKS. After the handle is complete, I made the pivot blocks from the strip cut off the handle blank. Start by cutting the strip 3/4" wide, and then cut 45° angles off the top corners, see Fig. 18. Next, drill two pilot holes near each end to accept the mounting screws. Then cut the 1 1/4"-long pivot blocks off both ends of the strip.

PINS. The handle is held to the pivot blocks with pins made from No. 6 screws. To do this, start by drilling a 3/32"-dia. hole centered on the inside end of each pivot block, see Fig. 19. Next, tighten a No. 6 x 3/4" screw into the hole leaving 1/4" of the shank showing. Then cut off the screw head.

MOUNTING THE HANDLE. To mount the handle, first center the handle and pivot blocks on the top of the toolbox. Leave about 1/16" between the handle and each block to prevent binding, see Fig. 20a.

Now, to locate the screw holes, tip the blocks on their sides and draw lines down from the two holes in the blocks onto the lid, see Fig. 20. After drilling shank holes at these points, tighten the pivot blocks down to the lid with roundhead wood screws.

CATCH. To complete the toolbox, I centered a catch on the front of the toolbox and screwed it down, see Fig. 21. Then file off the screws on the inside of the lid.

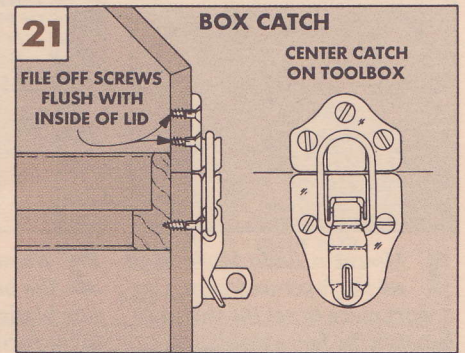
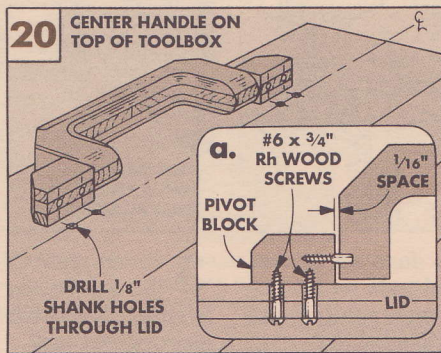
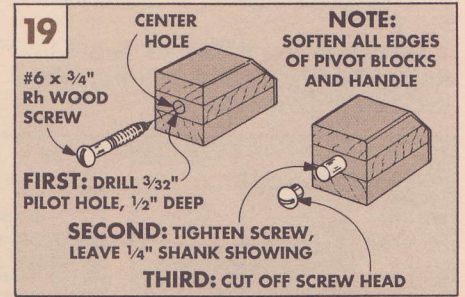
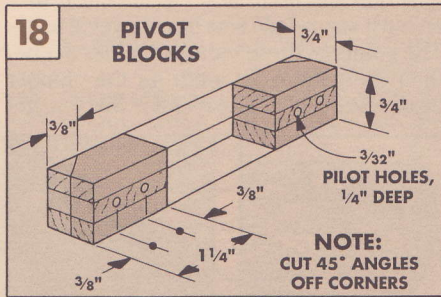
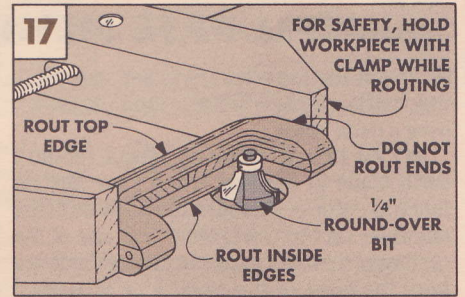
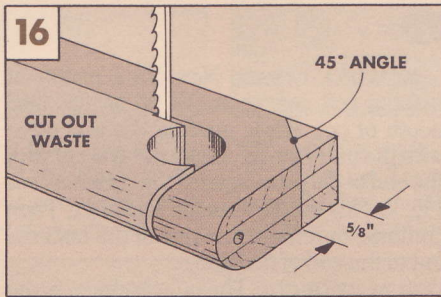
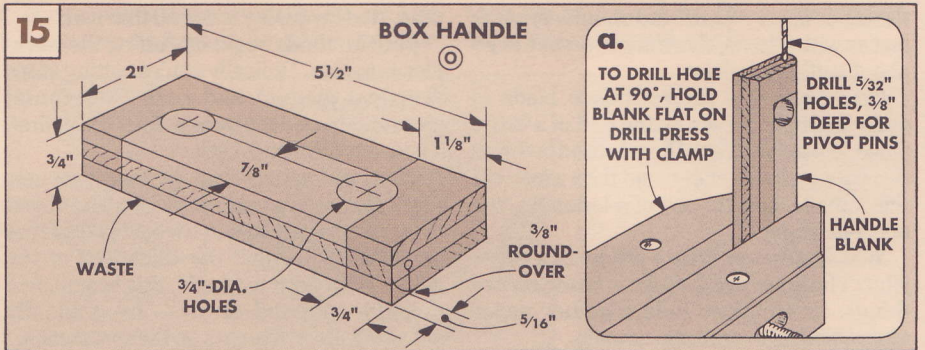
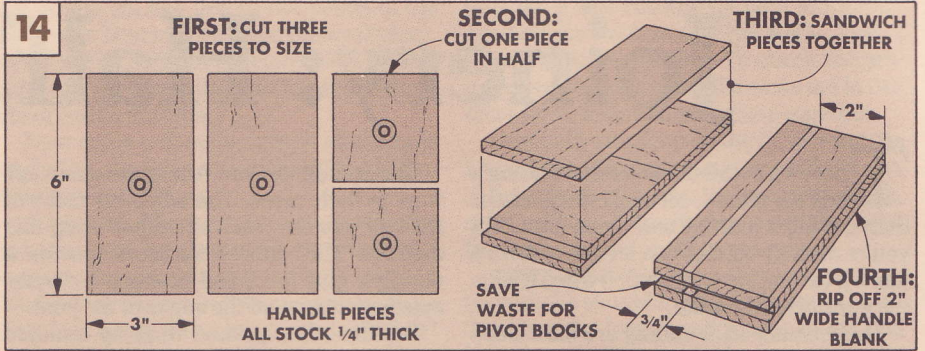

Joinery: Half Laps

There's a common belief that cutting a half lap is easy, certainly much easier than cutting a mortise and tenon joint. But you're actually cutting two *tenons* to form a half lap (or end lap as it's called when it joins the ends of two boards).

The tenons you're cutting are bare-faced tenons. That is, there's only one shoulder — the other face is "bare" (no shoulder). And, just as with tenons, there are two ways to go about cutting a half lap.

One method is to use a dado blade to make multiple passes on the end of a workpiece, see below. The other method involves two cuts: a shoulder cut, and then a face cut that's made with the aid of a tenon jig, see opposite page.

Which is easier? Which produces a better joint? The quality of the joint is based on two things: its ability to hold together under stress, and its overall appearance.

The second method (using the tenon jig) wins in both cases. The adjoining faces of the half laps are much smoother using this method. The smooth surfaces provide a stronger glue joint, and produce a cleaner appearance around the edges of the joint.

But the other method (making multiple passes over a dado blade) has a faster set-up time. And its quality is not all that bad.

Both methods begin by cutting the workpieces to size. Typically you're cutting stiles (vertical pieces) and rails (horizontal pieces). Rip all the pieces to final width first. Then, cut them to length.

Then no matter what method you use, you'll also need some test pieces. The object is to cut two half laps in the test pieces that are exactly one-half the thickness of the stock. With both methods, this is achieved through trial and error — by gradually sneaking up on the cuts on the test pieces.

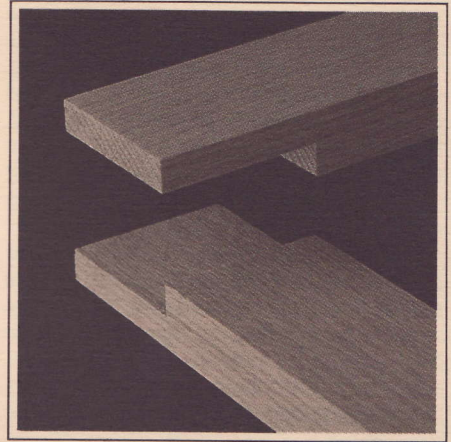

To make a good lap joint, the cuts have to be exactly one-half the thickness of the stock, and the faces should be smooth to provide a good gluing surface.

MULTIPLE PASS METHOD

■ One of the fastest ways to set up for cutting half lap joints is to make multiple passes over a dado blade.

SET RIP FENCE. To set up the cut, mount a dado blade in the saw. Then I use the rip fence as a stop to establish the position of the shoulder on the workpiece. Use one of the mating pieces as a gauge to adjust the fence until the edge of the workpiece is aligned with the outside edge of the dado blade, see Fig. 1.

SET DEPTH OF CUT. Next, set the height of the dado blade so it's a little *less* than half the thickness of the workpiece.

MULTIPLE PASSES. Now it's a matter of making test cuts to sneak up on the final depth of cut. While guiding the test piece with the miter gauge, make the first cut with the end of the piece against the rip fence, see Fig. 2. This establishes the shoulder. Then continue to remove the rest of the material out to the end of the piece.

QUALITY OF CUT. The only problem is the quality of the cut surface. The outside blades on most stack dado sets have beveled teeth. The points of these teeth cut a hair deeper than the square-cut teeth on the chipper blades, see Fig. 2. The result is that you get

a series of small V-shaped kerfs on the face of the cuts that show on the edges.

How do you get rid of the V-cuts? After making the initial passes, I hold the cut face over the dado blade and slide it right to left, while moving it forward and back with the aid of the miter gauge, see Fig. 3. The points of the beveled teeth "plane" down the surface so it's smooth.

To complete the joint, make passes on the ends of *two* test pieces and check the fit. Then gradually raise the blade (deepening the cut) until the outside surfaces of the pieces are flush, see Fig. 4.

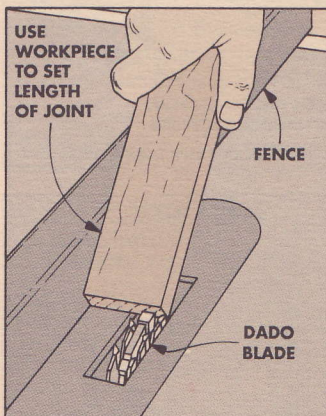

1 Mount a dado blade and set the fence as a stop. Use a workpiece to set the distance between the fence and blade.

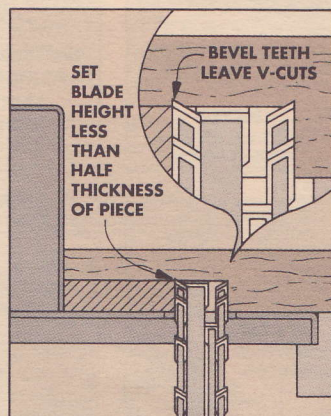

2 When a dado set is used, the bevel teeth on the outside blades make small V-cuts in the face of the half lap.

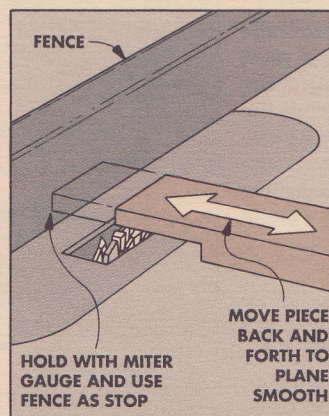

3 To remove the V-cuts, slide the workpiece right and left over blade while pushing it forward and back.

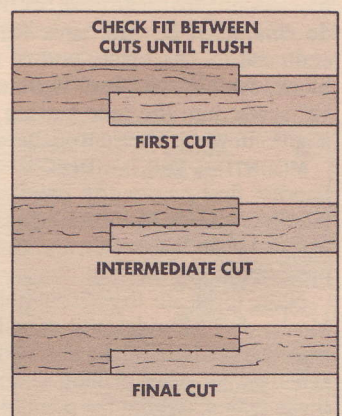

4 Make repeated passes over the end of two test pieces. Then check the fit until the outside surfaces are flush.

CUTTING END LAPS WITH A TENON JIG

■ The best way to get smooth surfaces on the mating faces of an end lap joint is to use a tenon jig. This not only produces a joint with a better appearance, but the smooth faces provide a stronger gluing surface.

SHOULDER CUT. To cut an end lap with this method, first you have to make a shoulder cut. This sets the length of the joint from the end of the workpiece to the shoulder line.

To make the shoulder cut on the stiles, use a rail to set the rip fence as a stop. Set the fence so the distance between the fence and the outside edge of the blade equals the width of the rail, see Fig. 5.

Next, I raise the blade so it's about $\frac{1}{16}$ " less than half the thickness of the stock. (I

set up the cut like this so the points of the blade don't cut too deep into the workpiece, refer to Fig. 5. Since it's easy to set the cut too deep, I set the initial cuts too shallow and clean up the cut later.)

Now make a shoulder cut in all the rails and stiles. And also make shoulder cuts in a couple of test pieces.

TENON JIG. The face cut is made with the aid of a tenon jig. First, raise the blade so it cuts into the shoulder cut, see Fig. 6. I set the blade a hair less than the top surface of the shoulder cut so the points of the teeth don't make a V-cut in the shoulder.

Now mount a test piece in the jig, see Fig. 7. Adjust the rip fence so the jig is in position

to make a face cut that's a little more than one-half the thickness of the stock. Then I sneak up on this setting. To check the progress, you have to make the same cut in two test pieces, and then hold them together.

Gradually sneak up on the fit, moving the fence (and jig) a hair at a time until the outside surfaces of the two test pieces are flush, refer to Fig. 4. When the test pieces fit, make the face cuts on the stiles and rails.

REMOVE CORNER. Since the initial settings on both the shoulder cut and the face cut are less than the length and height of the end lap, there will be a little corner at the shoulder of the end lap. Use a sharp chisel to cut this corner out, see Fig. 8.

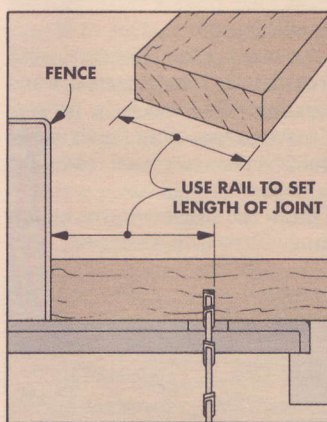

5 Set fence to cut shoulder equal to width of rail. Set blade height $\frac{1}{16}$ " less than half the thickness of the stock.

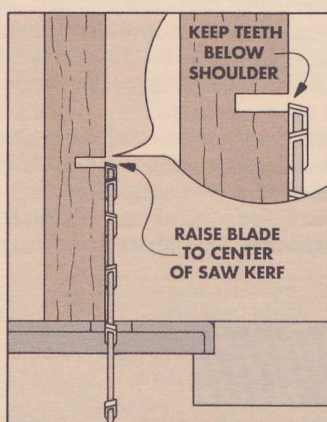

6 For the face cut, set the height of the blade so the highest point cuts about halfway into the shoulder cut.

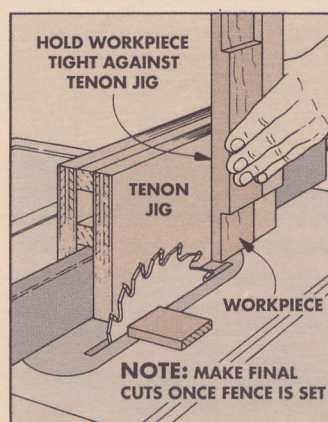

7 Hold the workpiece in the tenon jig. Then gradually move the fence until the blade cuts half the thickness.

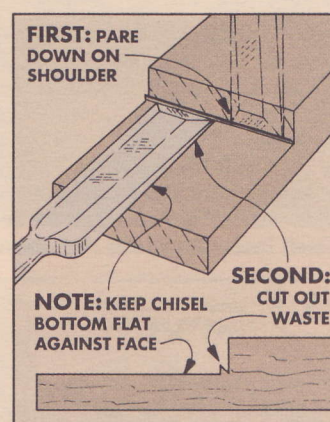

8 The settings described in Steps 5 and 6 leave a small corner in the shoulder that's removed with a chisel.

TENON CUTTING JIG

■ The jig I use to make the face cut for an end lap is the same one used for cutting tenons. Its whole purpose is to hold the workpiece vertical as it's guided through the blade.

The jig is designed to straddle the rip fence. This holds it in position and also provides a way to adjust its position in relation to the blade.

CUT PIECES. The jig consists of two faces held together with cross pieces. There's also a vertical stop at the end of the jig.

To make the jig, first rip two cross pieces to width to match the thickness of your rip fence. This width is fairly critical because you want a good friction fit against the fence when the face pieces are added.

If the pieces are a hair too

narrow, the jig will bind on the rip fence.

If the cross pieces are too wide, the jig will be loose on the fence. Then it's difficult to adjust when sneaking up on the face cut.

SHIMS. How do you get it perfect? I try to get the pieces right on the money. But if I'm off, I try to err by making them too narrow. Then I shim out with paper or old playing cards.

ADD FACES. After cutting the cross pieces, cut the face pieces about 6" by 12". Screw all these pieces together

and test the fit over the fence. Then add shims if necessary.

VERTICAL STOP. When the jig slides easily but firmly, add a vertical stop on the back end.

As this stop is added, make sure it's vertical to the saw table. The only other caution is to make sure the screws are above the path of the blade.

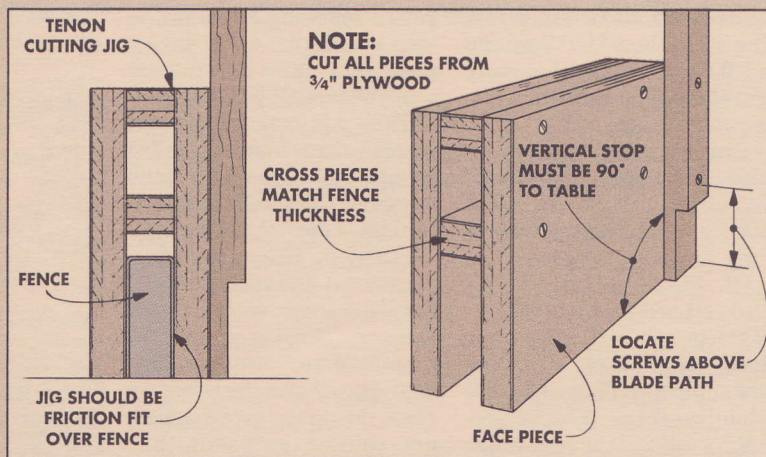

Resawing

Simply put, resawing is cutting thick boards into thinner boards. While the methods may differ, resawing can be done on a table saw or a band saw (see box below).

TABLE SAW. If the piece is less than 2" wide, it can be cut in one pass on a table saw with a rip blade. However, if the piece is wider than 2", you will have to cut it from both sides. (Note: With a 10" blade, the maximum depth of cut is about 3". This means the stock can't be wider than 6".)

THE FENCE. The first step in resawing is to mount a high fence on the table saw. I use a 6" high auxiliary fence that is screwed to the rip fence, see Fig. 1. This fence helps prevent the stock from tilting and makes it easier to steady the piece as it's being cut.

ROUGH CUT. After I've attached the high fence to the rip fence, I resaw in two steps. First, I raise the blade 1½" above the table

and set the saw fence to resaw the stock ¼" thicker than the final thickness I want.

Note: If you're cutting through dense lumber, you may want to reduce the height of your first cut.

Using a push stick, feed the stock through the blade while holding it tight against the fence, see Fig. 1. Then turn the piece over and make a second pass on the opposite edge, see Steps 1 and 2 in Fig. 2.

Try to cut through the stock in as few passes as possible. If the piece requires more than two cuts, raise the blade in 1" increments and cut the piece on both edges before raising the blade again, see Step 3.

FINISH THICKNESS. After cutting the piece in half (Step 4), you have a couple of options to get a smoother finish and remove any burn marks. You can hand plane the piece down to a finished thickness (see Shop

Notes, page 13), or you can make a final cleaning pass on the table saw, see Step 5. To make the final pass on the table saw, I switch to a 50-tooth combination blade.

Before making the cut, set up a featherboard so it's just ahead of the blade, see Fig. 3. The featherboard will keep the stock tight against the fence. Now adjust the fence to trim to the final thickness. Then raise the blade ¼" higher than the mid point of the piece so that the finish cuts can be completed in two passes.

When you're making the final cuts, push the piece through with steady pressure and without hesitating. This will help prevent burning and leaves a smoother finish on the face. After the first pass has been made, flip the piece and make the final cut.

Finally, if there are still any burns or saw marks, I remove them with a scraper.

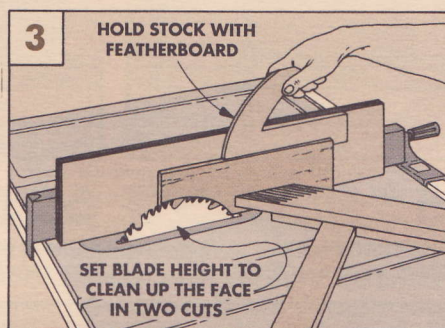
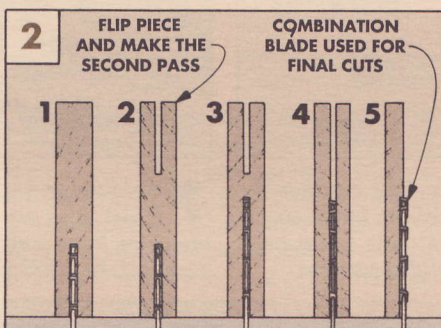
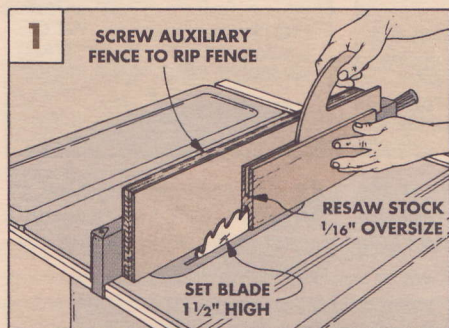

BAND SAW METHOD

■ If possible, I prefer to resaw on a band saw. There's less kerf waste and no danger of kick-back. Before cutting, make sure your band saw is tuned up. The blade should be sharp and set 90° to the table. (For more on setting up a band saw, see *Woodsmith*, No. 51.)

Begin by mounting the widest blade your saw will take. To keep the blade from bowing, set the blade guides so they are slightly above the stock. Finally, check that the blade is tensioned properly.

RESAW GUIDE. There's a tendency for the blade on a band saw to drift (pull to one side) while resawing. To compensate for this and to have a gauge

for consistent cuts, I use a simple shop-made guide as a fence, see Fig. 1. (Note: If the blade continually drifts or if you're resawing a number of long boards, set up an angled fence. For more information, see *Woodsmith*, No. 51.)

The guide for resawing short pieces is made from a scrap 2x4 clamped on edge on the band saw table. Cut a slight radius on the end of the 2x4, see detail.

CUT LINE. Before resawing, mark a cut line on the edge of the workpiece, with a pencil and a combination square.

MAKING THE CUT. Now, line up the mark with the band saw blade. Move the guide against one side of the board, then

clamp the guide to the table.

With the guide in place, you can begin cutting. Push the board tight against the guide. If you see the piece start to drift off the line, simply swing the

tail end of the piece in that direction and continue to push the stock through the blade. The radius on the end of the guide allows you to swing the piece without binding.

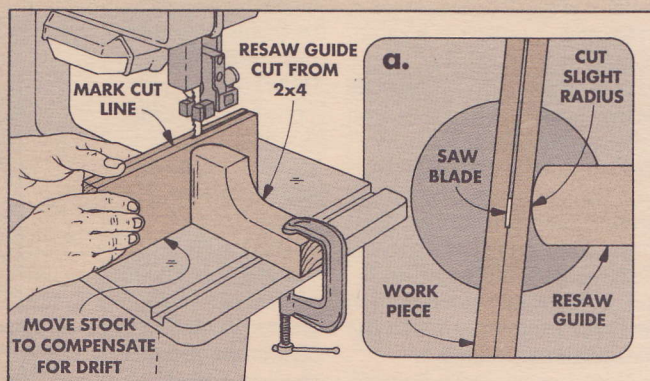

Talking Shop

THIN LUMBER

■ Two of the projects in this issue, the Tool Box and the Chisel Case, use thin (1/4") stock. That's something that you're not likely to find at your local lumberyard.

THICKNESS PLANER. The easiest solution is to use a thickness planer to surface the lumber to exactly the thickness you want.

Okay, let's be realistic. The cost of a planer is difficult for most home-shop woodworkers to justify — with one exception.

A few years ago, Ryobi introduced a light-weight 10" planer (the AP-10) that sells for less than \$450. Apparently, the price was right. Since then, thousands have found their way into shops across the country.

The compact size and light weight makes the Ryobi planer easy to store and move around. The surface it produces rivals the finish cut from machines costing much more. All in all, it's a tool we've recommended for home woodworkers who need a planer for occasional use—but don't want to spend thousands of dollars.

OTHER METHODS. Although a thickness planer is a great machine to have in a shop, for many home woodworkers the extra

\$400 is still a little beyond their shop budget.

So on page 13, we've described a couple of inexpensive techniques for "planing" resawn lumber. One of the methods uses a traditional hand plane, the other is a low-tech jig that employs a router to do all the planing.

If hand planing seems like too much work, there's a simple alternative — get someone else to do it. We checked around and found that some local cabinet or millwork shops will plane your stock down to 1/4" or less. The going rate for shop time in our area is about \$30 to \$40 per hour, and most shops have a minimum charge of \$15 to \$20.

BUYING THIN LUMBER. The final alternative is to buy thin lumber through the mail — which can be expensive. (For a list of mail order sources for thin lumber, see page 24.) Before placing an order, you should know a couple things about how thin lumber is usually specified.

SQUARE FEET VS. BOARD FEET. First, lumber under 3/4" thick is usually sold in *square* feet, not *board* feet.

Note: Board feet is the standard unit of measure when buy-

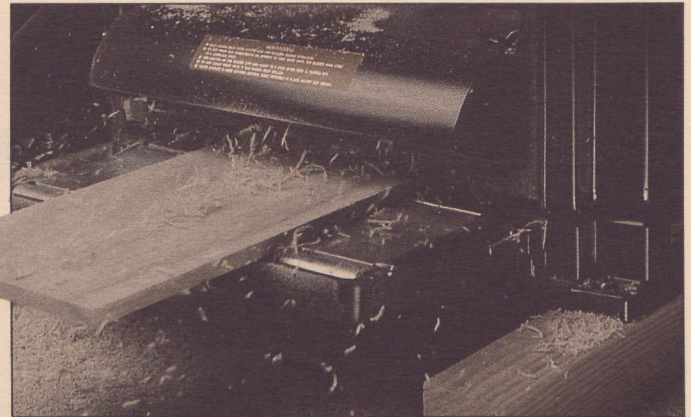

A thickness planer is one of the easiest methods for planing lumber smooth and to a consistent thickness. Pictured here

is the AP-10 planer from Ryobi. It produces a smooth finish down to as thin as 1/8" thick on 10"-wide stock.

ing hardwoods. It's actually a measure of *volume*. (For more information on board feet refer to *Woodsmith* No. 61).

The standard practice, when figuring *board* feet, is that any thickness less than 1" is still figured as if it were a full 1" thick. When dealing with thin lumber, this can get a little confusing.

It means that a 1/4"-thick board could be listed as having the same number of board feet as a 3/4"-thick board that's the same width and length — even

though the 1/4" board actually has less *volume* of lumber in it.

To eliminate the confusion, the standard practice is to list thin lumber as a surface dimension (square feet), rather than board feet.

WIDTHS AND LENGTHS. Another thing should be noted about thin lumber. It's often sold only in random widths and lengths. So you should order extra lumber to allow for possible edge-gluing, and to compensate for short pieces.

GLUE SHELF LIFE

■ *Is there a short shelf life for glue like there is for some finishes such as shellac?*

Wayne Boyd
Denver, Colorado

Since we use Titebond brand glue most of the time in the *Woodsmith* shop, I decided to call Franklin Chemical, the manufacturer of Titebond, to see if I could find the answer.

"Shelf life on Titebond and most of the other yellow glues is vague," explained Dennis

Doyle, of Franklin's Chemical Research Lab. "We advertise a minimum of one year. That would be from the time the consumer buys it. So, in reality, by the time the glue is used it could be 18 months or more from the date of manufacture.

That is subject to storage conditions. High temperature shortens storage life. If it's frozen and thawed 10 or 12 times, that would shorten it. But light (ultraviolet rays) doesn't have a negative effect on it."

How do you know if a bottle of glue may have reached its limit?

"If the glue starts to thicken or get very grabby, that's usually indicative of the fact it's on its way out. It won't change color."

Will it separate if it's bad?

"No. If there is a little bit of liquid separation at the top or a dark line around the top, it can be stirred back together. As long as you can stir it back in so it looks good, it is good."

In the fall of 1988, Franklin Chemical began putting expira-

tion dates on all bottles of Titebond (except gallons). If a glue bottle isn't labelled, you should date it yourself — especially if you're buying a large quantity. After I've had a bottle for a year, I start to get suspicious.

Also, it's best to buy from a dealer who sells a lot of glue. You'll have a better chance of getting a fresher stock of glue.

One other thing. I try to keep the lid or cap on the bottle to prevent the glue from getting a skim layer.

Sources

THIN LUMBER

There are several sources for thin lumber and we have listed a few of them at the right. Look for the code *TL* after the address.

TOOLBOX

The hardware that we used on the Toolbox is available through **Woodsmith Project Supplies** or from one of the catalog sources listed at the right (see code *TB*).

We are also offering all the thin lumber needed to build the Toolbox. The lumber is all kiln-dried hard maple, except the plywood which is 1/4" birch.

All of the maple has been surface sanded on both sides and all the edges are cut square.

Since the lumber is cut to special specifications, we are including a new cutting diagram.

Toolbox Hardware

- **763-100** Toolbox Kit... \$5.95
 - (1) 1 1/16" x 13" Brass Piano Hinge with Brass Screws.
 - (1) Box Catch with Screws.
 - (6) #6 x 3/4" Rh Brass Screws.

Toolbox Thin Stock

- **763-200** Thin Stock .. \$34.95
 - (12) 5" x 17" Pieces, 1/4"-thick.
 - (2) 3 1/2" x 17" Pieces, 1/2"-thick.
 - (2) 8" x 17" Sheets of 1/4" Birch Plywood.

CATALOGS

The following companies have similar hardware or supplies. Please refer to their catalog when ordering.

Albert Constantine
2050 Eastchester Rd.
Bronx, NY 10461
TL, TB

Bob Morgan Woodworking
1123 Bardstown Rd.
Louisville, KY 40204
TL

Craftsman Wood Service
1735 W. Cortland Ct.
Addison, IL 60101
TL, TB

The Woodworkers' Store
21801 Industrial Boulevard
Rogers, MN 55374
TL, TB

ORDER INFORMATION

BY MAIL

To order by mail, use the form on the protective cover of this issue or write your order on a piece of paper, and send it with your check or money order (please include \$1.50 shipping charge with each order). IA residents add 4% sales tax. Send order to:

Woodsmith Project Supplies
P.O. Box 10350
Des Moines, IA 50306

BY PHONE

For faster service use our Toll Free order line. Phone orders can be placed Mon. thru Fri., 8:30 - 4:30 CST.

Before you call please fill out the order form completely. VISA or MC orders only.

1-800-444-7002

Allow 4 to 6 weeks for delivery
Note: Prices subject to change after 12/89

PROJECT SUPPLY UPDATE

Woodsmith Project Supplies is now offering new hardware options for the two heirloom projects shown here.

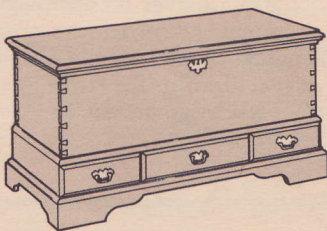

BLANKET CHEST

Woodsmith Project Supplies now has hardware for the Blanket Chest that we featured in *Woodsmith* No. 32. The kits include your choice of pulls (see photo) and all the necessary hardware for the project.

- **732-100** Kit BCA..... \$59.95
- **732-200** Kit BCB..... \$59.95
- **732-300** Kit BCC..... \$59.95

All of the above kits include:
(2) 2" x 3" Solid Brass Hinges
(1) Full Mortise Chest Lock
(1) Satin Brass Lid Support

This lid support features an adjustable tensioning rod that lets you fine tune the amount of resistance necessary to keep the lid in position. It also keeps the lid from slamming shut.

If you would like to purchase either the lid support or the pulls individually, specify the following order numbers:

- **732-104** Lid Support . \$22.95
- **732-101** Pull BCA . \$4.95 ea.
- **732-201** Pull BCB . \$4.95 ea.
- **464-753** Pull BCC . \$4.95 ea.

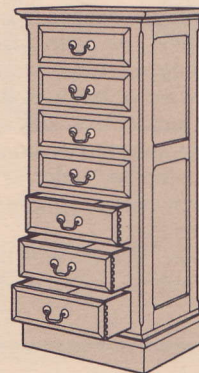

LINGERIE DRESSER

Woodsmith Project Supplies also has three hardware kits for the Lingerie Dresser in *Woodsmith* No. 53. Each kit contains your choice of drawer pulls (see photo) and all the hardware to complete the project.

- **753-110** Kit LDA..... \$39.95
- **753-120** Kit LDB..... \$39.95
- **753-130** Kit LDC..... \$24.95

All three of these kits also contain the following:

(7) plastic retaining buttons (used for the drawer stops).

(20) feet of self-adhering plastic glide strip for the drawer slides.

If you need extra parts or would like to use this hardware on another project, we are offering the drawer pulls and the glide strip individually. (The glide strip comes in 10 foot lengths only.)

- **753-112** Glide Strip..... \$4.95
- **464-753** Pull LDA . \$4.95 ea.
- **464-722** Pull LDB . \$4.95 ea.
- **753-131** Pull LDC . \$1.25 ea.

