

BUMPER ISSUE! INCLUDES £1,500 OF PRIZES TO BE WON

EASY IKAT

carry-all bag

16 step-by-step tutorials

I love Sewing

THE UK'S NO.1 SEWING MAGAZINE

7 STYLISH GARMENTS

you'll love to make

SIZES 6-20

MAKE THE TREND!

OFF-THE-SHOULDER DRESS



SIZES 4-26

FOR ALL AGES



FUN T-SHIRT APPLIQUE

PLUS! 45 PAGES OF EXPERT ADVICE

- ♥ Fabric & pattern picks for scuba sewing success
- ♥ Use eyelets to make an on-trend lace-up top
- ♥ Match stripes across sleeves with Alison Smith MBE

20% OFF AT GIRL CHARLEE FABRICS ♥ TROUSERS INTO DUNGAREES DIY

Inspire Imagine Create

ISSUE 31 UK £6.99 31 >

9 772054 832999

www.love sewingmag.co.uk



15% OFF

using code

Love15

and **FREE**
UK delivery

Sew2go[®]

RUFFLER FOOT £15.99

PREMAX SCISSORS £15.25

**DOMESTIC
SEWING FEET**

*All your dressmaking
essentials in one place*

- 1 Bias Binding Foot**
code: 5011-19 £5.50
- 2 Pintuck Foot** code: 5011-21 £2.50
- 3 Satin Stitch Foot**
code: CY-7303 £2.95
- 4 Combination cording foot**
code: CY-706L £2.50
- 5 Snap On Edgeloock Foot**
code: ALF-A1 £3.49
- 6 Decorative Foot for Shank**
code: EMF-A1 £3.99



www.sew2go.co.uk

Tel: 01484 88 88 88 | support@eastman.co.uk

Sew2go[®]



Welcome to the new issue of Love Sewing...

It's exciting to be able to share this fun nautical edition with you and the fabulous new pattern from Simple Sew. The Shannon collection features four garments in our broadest range of sizes, 6-20. I can't wait to make a pair of the **stylish wide-leg trousers** and know there will be a few versions of the **ultimate jersey dress**. Keeping the size range as inclusive as possible is very important to us and I hope to see many of your versions on social media.

If you're keen to try the dungarees trend, Elisalex will show you how to adjust the Shannon pattern in her column this month on **page 26**. You can also learn to make a lace-up top and a classic A-line skirt. If you prefer your dresses more floaty and feminine, you can try the Sutton off-the-shoulder dress on **page 42**.

We're also sharing our top tips on adding scuba fabric to your wardrobe on **page 54**

Find us online
WWW.LOVESEWINGMAG.CO.UK
WWW.FACEBOOK.COM/LOVESEWINGMAG
WWW.TWITTER.COM/LOVESEWINGMAG
WWW.PINTEREST.COM/LOVESEWINGMAG
WWW.INSTAGRAM.COM/LOVESEWINGMAG



and choosing your perfect nautical style on **page 30**. Head to Claire-Louise Hardie's column on **page 46** to learn how to trace your existing clothes, and Wendy Ward is sharing what goes into writing a craft book on **page 12**. There is also a whole host of fun home and children's projects in this issue, all with a fun nautical twist.

If you have made something from this issue or a previous one, don't forget to share it online using the hashtag **#lovesewingmag** and tag us on social media! I love hearing from our readers and respond to as many messages as possible directly. So don't be a stranger and drop us a line to **letters@lovesewingmag.co.uk** when you have comments or pictures to share.

Happy sewing!

Amy x



Inside this issue...

REGULARS AND FEATURES

- 3** WELCOME
- 6** LOVE SEWING LOVES
- 10** LOVE SEWING LIBRARY
- 12** BEHIND THE SEAMS
with *Wendy Ward*
- 15** READERS' MAKES
- 16** THIS MONTH I'M MAKING
- 18** BIG VINTAGE SEW-ALONG NEWS
- 26** THE DRESSMAKER'S DIARY with *Elisalex de Castro Peake*
- 30** FIND YOUR NAUTICAL STYLE
- 34** PATTERN PICKS
with *Rosabella Riddington*
- 46** THE THRIFTY STITCHER
with *Claire-Louise Hardie*
- 54** FABRIC FOCUS: NEOPRENE & SCUBA
- 60** SEWING ROOM SWOON
with *Jen Walker*
- 68** MEET THE FELT MISTRESS



Must have!

Your **FREE** Simple Sew pattern

77 ANNOUNCING THE STITCHER OF THE YEAR WINNERS

80 COUTURE SEWING
with *Alison Smith MBE*

82 BRIEF HISTORY OF NAUTICAL FASHION

85 BASICS OF PATTERN READING

86 IRON REVIEWS

88 CLASSES, COURSES & WORKSHOPS

91 DISCOUNTS & GIVEAWAYS

95 SHOP OF THE MONTH

96 COMING NEXT ISSUE

PROJECTS

21 YOUR FREE PATTERN GIFT – THE **SIMPLE SEW** SHANNON COLLECTION

28 ELLEN LACE-UP TOP

36 ESSENTIAL A-LINE SKIRT



39 SCALLOP POCKET TUTORIAL
from *Ashley Cramp*

42 SUTTON OFF-THE-SHOULDER DRESS

49 INTREPID EXPLORER RUCKSACK

51 BOXY IKAT TOTE

56 CATCH OF THE DAY BUNTING

63 TICKING STRIPE DOORSTOP

65 MAGICAL MERMAID DOLL



69 WASHING LINE PLAY TENT

71 PLUCKY PELICAN APPLIQUÉ

74 TINY TURTLE RATTLE

98 30-MINUTE MAKE: HANDBAG TASSEL



49



28



98



71



69

Editorial
 Editor Amy Thomas
 Deputy Editor Bethany Armitage
 Editorial Assistant Felix McNulty
 Senior Sub-Editor Justine Moran
 Sub-Editor Kayleigh Hooton
 Senior Art Editor Denise Johnson
 Designers Simon Kay, Sarah Edmondson, Suzanne Guest
 Senior Product Photographer Tym Lecky
 Photographers Alex Wright, Dan Walmsley
 Hair & make-up Nina Rochford
 Contributors Claire-Louise Hardie, Alison Smith MBE, Elisalex de Castro Peake, Wendy Ward

Publishing & Advertising
 Head of Business Development Ruth Walker
 Advertising Sales Executive Noun Sarkissian
 noune.sarkissian@practicalpublishing.co.uk
 Advertising Consultant Jane Bates
 Subscriptions Manager Daniel Tutton
 Senior Editor Kate Heppell
 Managing Art Editor Jennifer Lamb
 Head of Content & Positioning Gavin Burrell
 Head of Product Development Carol Jones
 Group Buying Manager Olivia Foster
 Buying Assistant Rachael Edmunds
 Production Assistant Anna Olejarz
 Commerce & Distribution Director Dave Cusick
 Managing Director Danny Bowler
 Group Managing Director Robin Wilkinson

Distribution
 Newstrade COMAG Magazine Distribution
 jane.bates@practicalpublishing.co.uk
 Tel 0844 826 0613

Contact
 Practical Publishing International Ltd,
 Suite G2 St Christopher House,
 217 Wellington Road South,
 Stockport SK2 6NG
 info@practicalpublishing.co.uk
 www.practicalpublishing.co.uk
 Tel: 0844 561 1202
 Fax: 0161 474 6961

Subscription Enquiries
 Tel: 01858 438899

Love Sewing is published by Practical Publishing International Ltd ISSN 2054-832X

All material © Practical Publishing International Ltd. The style and mark of Love Sewing is used under licence from Craft Media Ltd. No material in whole or in part may be reproduced, stored or transmitted in any form whatsoever without the prior written consent of Practical Publishing International Ltd. The publisher welcomes contributions from readers. All such contributions and submissions to the magazine are sent to and accepted by the publisher on the basis of a non-exclusive transferable worldwide licence unless otherwise agreed in writing prior to first publication. Such submissions are also subject to being used, reproduced, modified, published, edited, translated, distributed and displayed in any media or medium, or any form, format or forum now known or hereafter developed, for any purpose, in perpetuity.

Stock images provided by Shutterstock, Inc
 Practical Publishing International Ltd is a member of the PPA

Contributors



Laura Minter and Tia Williams
 Laura and Tia are two best friends and mums from Brighton. They began their craft blog, Little Button Diaries www.littlebuttondiaries.com, three years ago and are currently writing their fifth craft book for children. Make their sweet turtle rattle on page 74.



Jen Walker
 AKA The Gingerthread Girl, crafty redhead Jen Walker has been sewing since 2014 and showcases her creative makes and musings on her blog www.gingerthreadgirl.co.uk On page 60 Jen shows us round her fabulous sewing space.

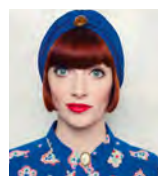

Amber Butchart
 You may know Amber from her guest spots as fashion historian for *The Great British Sewing Bee*, but on page 82 she's sharing her knowledge of nautical dress with us! Learn more about Amber's work at www.amberbutchart.com

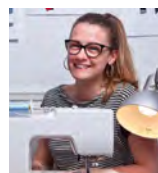

Wendy Ward
 Wendy is a sewing book author and runs the MIY Workshop in Brighton where she teaches dressmaking and pattern cutting. In this issue she spills the beans on what it's like to write a sewing book – head to page 12 to find out more!

love Sewing loves...

Buys & inspiration

The patterns, people, fabric and finds getting us sewing this month



Simple Sew

Charlotte DRESS



~£12.50~

This elegant and versatile Charlotte dress has six views in one pattern pack thanks to two necklines, two sleeve lengths and a sleeveless option. We love this swallow print poplin from Fabric Godmother, perfect for a subtle nod to seaside style. Pick up some of this fabulous fabric for £6.25 per metre at

www.fabricgodmother.co.uk and find the full Simple Sew pattern line at www.simplesewpatterns.com

Sizes 8-20

SEWING STRUCTURED BAGS: Purse Frames & Beyond



sewing structured bags
PURSE FRAMES & BEYOND

This technique is in the bag! Join bag-making expert Lisa Lam as she shares easy-to-follow instructions for creating refined, durable bags using exterior and interior purse frames. She'll share expert advice, tips and step-by-step instructions to create two purses, the Easy Peasy Purse clutch bag and the roomy Carpet Bag.

Love Sewing readers can claim a special 50% off this Craftsy class by using the link www.craftsy.com/ext/LisaLam_11222_H



The New York Times goes behind the Scenes MCCALL PATTERN COMPANY

In its recent article entitled “Do-It-Yourself Fashion Thrives at the McCall Pattern Company”, the *New York Times* visited the iconic sewing brand’s head offices to talk to members of the team and find out why an interest in sewing has persisted through the decades.

The article features comments from blogger, author and pattern designer Gretchen Hirsch whose recent pattern line for the company saw her on the cover of the latest catalogue.

With exclusive images of the pattern drafting and garment construction rooms plus a peek inside the photography studio it’s a rare treat

We recommend you check out the article for yourself to see exciting glimpses of the team’s workspace at www.nytimes.com/2016/08/04/fashion/mccalls-pattern-company-sewing-do-it-yourself.html

BUILDING BLOCK DRESS BOOK *by Liesl Gibson*



Coming soon!

Oliver + S has a strong reputation with people who like to sew and who appreciate cute children’s clothing as well as the Liesl + Co women’s sewing patterns, which also feature excellent instructions. We’re happy to share that Liesl has written a new book called the Building Block Dress Book that will be available in mid-September, priced £21.

The book is subtitled A Sewing Pattern Alteration Guide because it offers a new approach to sewing books. It enables the reader to become a dress designer, without requiring years of education or experience, by altering a dress block (sizes 6M-12) which is included with the book. Stay tuned for further info on this sure-fire hit of a book!



BAKE OFF IS BACK!

Series 7 of the hit TV show has returned and with it a whole host of new fabulous jackets from Mary Berry

It’s easy to whip up a stylish bomber jacket using the Sports-luxe bomber pattern by The Maker’s Atelier, available as a printed pattern in sizes 8-18 from www.themakersatelier.com for £22.50.

We recommend pairing this (1) stunning Japanese bird print cotton from www.remnantkings.co.uk priced £13.99 per metre with this turquoise cotton ribbing (2), which is €3.75 (approximately £3.23) per half metre from www.dressfabrics.ie

MAKE YOUR SEWING LIFE EASIER

Janome bias binding foot, £17

Make your sewing time more stress-free by investing in an amazing new machine foot that will help create a professional finish to your garments, quilts and home projects. Janome's binder foot is used to apply pre-folded bias binding tape or bias tape that you've cut yourself to the edge of your fabric in one easy step as it won't shift about as you install it. Discover more amazing machine feet like this one in our free Janome sewing machine guide and head to www.janome.co.uk to see the full range of feet on offer.



Madalynne x SIMPLICITY LINGERIE DESIGNS

With lingerie making becoming a new favourite in sewing circles, Simplicity Patterns has joined forces with stylish sewing blogger and designer Maddie Flanigan, to create a line of gorgeous lingerie patterns. The designs are perfect for stitchers looking to achieve that perfect fit and stretch their skills.

The first pattern features an underwired bra with a simple brief design, whilst the second is a dramatic soft cup bra with halter and racer back options, paired with lace-trimmed knickers. Each pattern includes helpful information on bra sizing, notions, fabric selection and general tips for lingerie sewing. The bras are designed for sizes 32A-DD through to 42A-DD, and the knickers for sizes XS-XL. With all sizes in one envelope, the pattern is priced at £8.15.

Pick up the patterns from the www.simplicitynewlook.com site and step into Maddie's inspiring world by following her blog www.madalynne.com and Instagram account [mmadalynne](https://www.instagram.com/madalynne).





THREAD, *a festival of textiles*



The Farnham Maltings festival of textiles is returning for its fourth year on 24th September, with a programme of classes and activities for 2016 to get creative people of all abilities involved, including highlights such as workshops with Emma Hobbs, Miesje Chafer, Rosie Martin and Genevieve Brading of Floss & Mischief. As well as classes, there will be a series of talks, exhibitions and demonstrations and a full curated marketplace to shop for fabric and haberdashery. To find out more and book tickets, head to www.farnhammaltings.com

love Sewing library

Our pick of this month's new sewing and dressmaking books



SUNDRESSING

by *Melissa Mora*

£16.99 **Fons & Porter**

This sumptuous and warm collection comes from Melissa Mora of the 30 Days of Sundresses blog series. The projects in the book reflect the style characteristic of Melissa's blog – fashionable, comfortable and current – and are suited to a range of abilities, including beginners and improves

building their confidence. There's 20 different sundress designs to pick from based on four basic blocks, alongside detailed instruction, fabric advice, and even a bonus section with tips on how to style a sundress in colder months on the year.



MAKE THIS DRESS
See page 42



Parlin Dress

With a contrasting bias collar and waist, the Parlin Dress can be a work appropriate staple for warm weather. Have fun playing with color combinations on this retro dress.



CROSS STITCH: 12 FUN PROJECTS TO MAKE

by *Sarah Fordham*

£5.99 **GMC Publications**

This fabulously cool collection brings quirky modern trends together with traditional techniques to truly fantastic effect. Each project is versatile and accessible, and there's plenty of useful information on the basics for newcomers to cross stitching. Once you've mastered these 12 designs you can use them for brand-new projects of your own or customise them so they're perfectly suited to you. A fantastic source of inspiration for embellishment ideas!



TEXTILE NATURE

by *Anne Kelly*

£22.50 **Batsford**

This inspirational guide to incorporating the beauty of nature into textile art projects is a gorgeous stitchy celebration of the flora and fauna of the natural world. Plants, flowers, garden scenes, insects and birds all feature in a range of step-by-step projects and advice on everything from sketching and

drawing inspiration to 3D sculptural work with textiles. There's plenty of input from experts and artists throughout, making this a perfect resource to get started on some projects a little different from what you're used to!





Book of the Month

NAUTICAL CHIC BY AMBER JANE BUTCHART

£24.95 Thames and Hudson

Since this is our nautical issue, what more obvious choice for Book of the Month than this engaging and meticulously researched history of nautical influence on clothing from renowned fashion historian Amber Butchart?

Hello! How are you today? To start at the beginning with the book, could you tell us a bit about what drew you to nautical style specifically?

Hi! I'm good thanks! Well I grew up by the seaside, so nautical and maritime clothing and coastal life has always been a really big interest for me. When I did my Masters degree at London College of Fashion I specialised in looking at nautical influences on mid-Victorian womenswear, specifically the effect of the 19th century sailor's uniform. So it's been a long-running research interest of mine really, stemming from personal interest and partly from my own love of dressing like a sailor!

What do you think can be benefitted from connecting history with something as every day as the clothes we wear?

As a fashion historian, my interest is in telling stories about the past through the clothing that we wear now. I think that dress and clothing can be a visceral way into history, because we wear clothes on our bodies as you say every day, we interact with clothing every day and so the hope is that it can lead us into stories about the past. What I do as a fashion historian is look at clothing choices or the dress of particular communities and I see how that connects with

wider stories about the culture and society that produces them.

Why do you think working uniforms continue to be reinvented within fashion?

With work wear, I think that as societies in the West, particularly the middle classes, move further away from manual labour, there's a certain amount of fetishisation or working life that occurs. I think also a lot of the time there's a genuine interest and appreciation for clothing that has a practical as well as aesthetically pleasing element to it, so if you think of fishermen's smocks and the way they're often worn by artists, and the Breton top, these are good examples.

Do you have a favourite of the five archetypal figures – for the benefit of our readers, the Officer, Sailor, Fisherman, Sportsman and Pirate – that you explore in the book?

I'm not sure I could actually give a favourite, I'm in love with them all in different ways. The sailor definitely has the most resonance with me in terms of the way that I used to dress, but I enjoyed researching each of them – the pirate, obviously, was loads of fun, and I ended



up really falling in love with a lot of American mid-century leisurewear when I was researching the yachting chapter.

Which of the five do you think is most influential to wider fashion?

One of the main reasons I was interested in writing the book is because the Sailor and Officer are really perennial spring catwalk looks – there will always be nautical influences from these two perspectives. The Breton top as well has become a kind of chic classic and is really dominant in a lot of street-style blogs. So of the five, the Sailor and the Officer are the really recurring looks that we see again and again.

Finally, what can we expect from you next?

My new book *The Fashion of Film* is actually just coming out. It's an exploration of the ways in which cinema has influenced style and looks at 45 key films across seven genres – romance, sci-fi and horror to name a few – over the last century.



Look out for *The Fashion of Film* (Mitchell Beazley, £30) hitting the shelves near you or grab your copy at www.octopusbooks.co.uk

BEHIND THE SEAMS

with *Wendy Ward*

Got a question for Wendy Ward?
Email us at letters@lovesewingmag.co.uk

What is it like to write a sewing book?



My new book *A Beginner's Guide to Making Skirts* is out next month and credit for this month's column must go to Editor Amy who said to me a few months ago: "I hope you'll be writing about what it's like to write a sewing book for your column!" What a great idea, why didn't I think of that? I guess that's why she's the editor!

The whole process began with an email from CICO when I came back from holiday last

year. Once I'd written a detailed proposal for the book including a contents list, research about why the book should exist, who it was aimed at and some design ideas it was finally commissioned in October 2015. That might sound like a lot of work to do before I knew if the book would even be commissioned, but all that preparation and planning was invaluable – it was then full steam ahead and I had until early December to complete the first three projects.

Although most readers might think of the author as the main person in the production of a book, it's the combined effort of a tight team of people. Trust is one of the key elements in the production of a book, especially craft titles that are so reliant on imagery. Soon after commissioning I went to meet with the CICO team where we discussed the overall look and style of the book. Everyone brought along ideas and it was such a relief to see we were all on the same wavelength! As an author it's

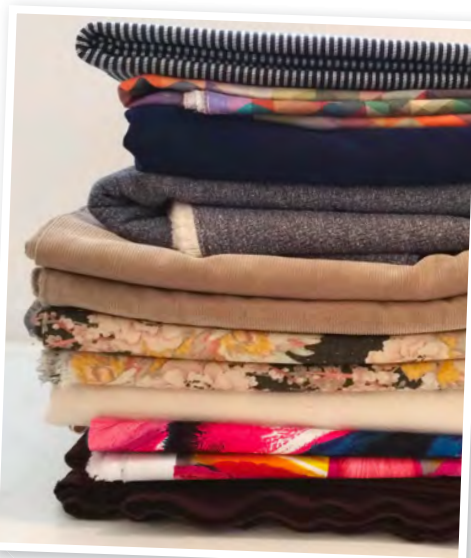

About me

I design my own range of easy-to-follow modern sewing patterns called MIY Collection. I am a qualified teacher and also have a degree in fashion and spent seven years working in the fashion industry before starting to teach dressmaking from my own studio called MIY Workshop in Brighton in 2011. My first dressmaking book *The Beginner's Guide to Dressmaking* is available now and my second book *A Beginner's Guide to Making Skirts* will be available in October.

www.wendyward.co.uk

www.miyworkshop.co.uk

www.miycollection.com



Experiments in hand-dyeing fabric

incredibly important to me for my books to reflect my style and be identifiable as my work, but likewise it's important for the publisher to produce a book that complements its style and will sell.

Once an overall style had been agreed, the fun could begin and what always happens at the start of every dressmaking project – fabric shopping! I am lucky to know some fabulous fabric people and bought most of the fabric for my samples from Gill at Ditto and Fiona at Faberwood. The remainder came from my stash. I was also super excited to work with my good friend Ce of The Uncommon Thread on some experiments in hand-dyeing fabric, so there are some unique samples in this book.

Then began the sampling, those wonderful hours spent alone in the MIY Workshop listening



to the radio, drafting patterns and cutting fabric to turn my designs into reality. There are eight projects in the book all with three variations – that’s 24 skirts I needed to make, not including the rough initial toiles I made to check and tweak my patterns.

While doing this I was writing the step-by-step instructions too. I like to make notes while I’m sewing as this way I remember the little quirks and things that might catch people out. All the time I’m thinking ‘what’s the best way to explain this? What parts would someone without much experience find difficult?’ Here I can draw on my teaching experience. If you haven’t witnessed a complete beginner hopelessly muddled by a pattern you’re going to struggle to imagine



Photo shoot dream team: (L to R) Julian (photographer), Anna (editor), me, Rob (stylist)

yourself in their shoes when you’re writing clear instructions you want them to be able to follow.

Next came the photo shoots, three of them – one in December, one in March and the last in April. I made nine samples for each of the first two shoots and six for the final one. Part of the joy of photo shoots is working with other creative professionals. They’re long, tiring days and so much easier if you’re in tune with each other’s ideas and work well together. Luckily for me I had a wonderful team; two great models in Lucy and Rachel, a fabulous (and hilarious) stylist in Rob, Julian the talented photographer – who also shot my first book – and Anna my editor from CICO who did a great job of looking after us all. Sadly, my dogs didn’t get into this book as we shot in studios in London, but watch out for them making a guest appearance in some accompanying video tutorials that we’re currently filming!

Once the projects were finished and photographed, the techniques section of the book needed to be written and illustrated. As well as the text, I did all the diagrams for this book. In total it was over 20,000 words and over

300 illustrations. Editors who work on craft books have to be such sticklers for detail, I love working with people like that, who won’t let the slightest little thing get past them. Sarah, my editor for this book, was just that and although we never met, I feel like I know her well from the many conversations we’ve had about seemingly small details at odd hours of the day and evening (one of which was the day before Christmas Eve. Yep, dedication, that’s what you need!).

Writing a book is a wonderful thing to do. Being able to devote lots of time to create new projects and working with a talented team of experts to bring it all together is immensely satisfying. To write a book alongside running a business full-time is certainly difficult though; I spent a good six months while writing this book often working over 60 hours a week without a day off and the rest of my life outside work was put on hold. It isn’t for everyone, nor is it a guaranteed way to earn your fortune. In these days of free online resources, it’s difficult for publishers (and therefore authors) to turn a profit, but the satisfaction of seeing my books on the shelves of bookshops, in the hands of makers and to see the wonderful things that readers make from them is a feeling that money can’t buy.



Photo shoot fuel!



Behind the scenes

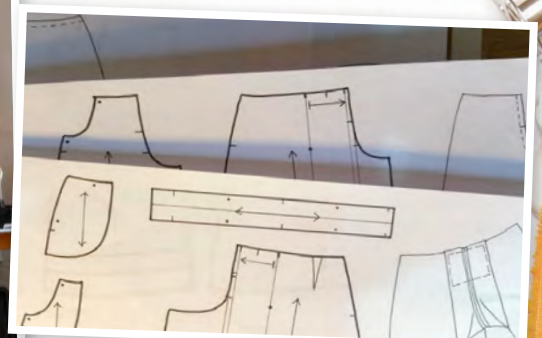



HOCHANDA

HOME OF CRAFTS HOBBIES AND ARTS

FREEVIEW 39 (6AM-9PM)

FREESAT 817 (24/7)

SKY 663 (24/7)

THE UK'S
INSPIRATIONAL
CRAFT TV CHANNEL



TUNE IN TODAY...
OR WATCH ONLINE AT
WWW.HOCHANDA.COM

NEW
CRAFTS

Readers' MAKES

If you've made something using the projects or patterns in *Love Sewing*, tell us about it and we'll publish it.

Share it on our Facebook page or email us at letters@lovesewingmag.co.uk. Each month's Star Make will receive a Minerva Crafts fabric bundle worth £25, handpicked by Vicki at Minerva!

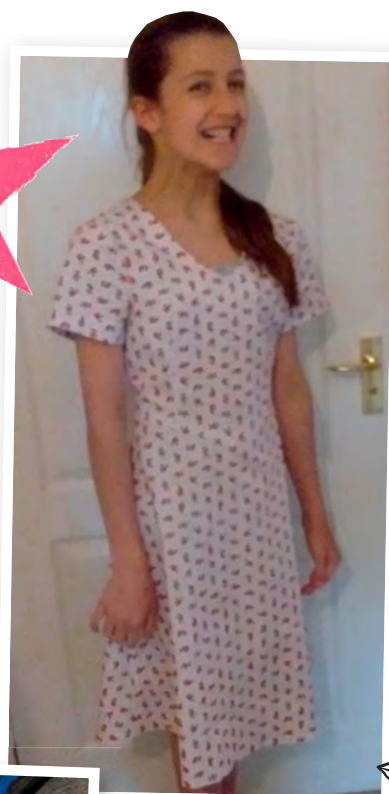

We love the adorable fabric **Becky Audsley** chose to make her Thelma dress from issue 24!

Kerry Parsons loved issue 30's peg bag so much she had to make it straight away! Pretty and practical



This tea dress made by 12-year-old **Suzannah Moesbauer** looks fantastic, and we're extra impressed as it's her first make!



Joan Wall has adapted her Amelia tea dress by rounding the neckline and adding a bit of length for a comfortable summer garment



Valeria Speck's husband looks dashing in this Men's classic T-shirt from issue 23. See more from Valeria at www.valeriaspeck.com



Instagrammer **skirtallweek** used denim from www.flojoboutique.co.uk and Prym snaps to make her fabulous Simple Sew button-down skirt

Like what you see but don't have a copy of the issue? Back issues of *Love Sewing* can be found at www.moremags.com or in digital form at www.pocketmags.com

This month I'm making...

Mini Octopus Dress

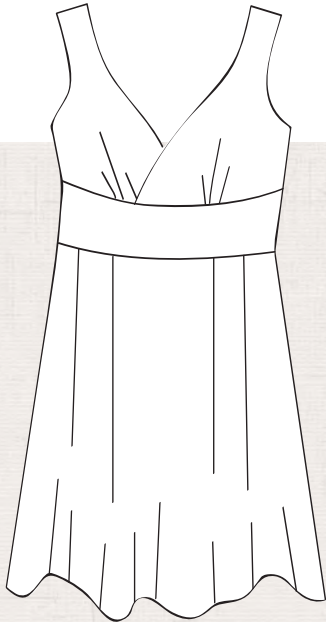

THE MINERVA CRAFTS BLOGGER NETWORK

The Minerva Crafts Blogger Network is a collection of amazing sewing and craft bloggers from across the world. Every month each blogger creates a unique kit from the thousands of gorgeous fabrics and notions available at Minerva Crafts. They wow us with their makes every month by blogging a project made with their kit on the network. There are new projects going live daily to inspire and educate sewists of all levels and abilities. Each blogger's unique kits are available to buy at www.minervacrafts.com

We love a unique and quirky print here at Love Sewing HQ, and our current crush is this super-cute octopus dress made by Thread Carefully blogger Louise! You can see more from her blog at www.threadcarefully.org

I made this novelty print dress to go with a necklace I stole from my daughter. Seriously! My friend Martha gave some of her old costume jewellery to my daughter for playing and dressing up with, and when I saw this necklace I just had to have it for myself! How low can you go, eh?!

Once I had stashed the necklace safely amongst my own jewellery, I searched Minerva's website for some octopus fabric, and this Timeless Treasures Mini Octupi instantly came up. WINNER. Did you know, though, that 'octopuses' is actually the correct plural form of the noun 'octopus', rather than 'octopi', which many suppose to be correct and is in common usage?

I used the Surplice dress sewing pattern from Gretchen Hirsch's latest book *Gertie's Ultimate Dress Book*, which was very kindly sent to me as an unexpected gift earlier in the year. The pattern is fine but be aware that almost all of the skirt patterns in this book are so wide that you are required to cut on the cross grain – which is OK, as long as you don't have a directional print as I did. I had to use a skirt pattern from a different dress – one of my favourite skirts actually – New Look 6776.

I think perhaps when I ordered my supplies from Minerva, I had been thinking of making the Sailor dress instead, because I ordered quite a bit of lining fabric. I found out the Surplice dress is not lined, and uses facings to finish the raw edges, but I decided to line the skirt anyway so that I can easily wear the dress in colder weather over tights.

Whenever I line pleated skirts, I usually sew the pleats of the main and the lining fabric together, but



keep the side seams separate and hem them separately too, so that the pleats are nice and neat but the lining can hang free. I did a lapped zipper at the back – I am starting to prefer them to concealed zips because it isn't always very comfortable having the zipper teeth pressing into your skin when you lean back!

The dress was very easy to make, really, and I like the bodice because it is different to most of my other dresses. Most of all I'm happy to have a dress to match the necklace! Thanks to Minerva for the fabric, lining, thread and zipper, all of which were fabulous as usual.

To find out more and get hold of the materials used, head to www.minervacrafts.com/blogger-network/post/mini-octopus-dress

Sew many

possibilities

Presenting the Singer 7463 Confidence

- * Easy stitch selection
- * 30 Built-in Stitches
- * Push-button stitch selection
- * Automatic stitch length and width
- * 2 Fully automatic 1-Step buttonholes
- * Automatic needle threader
- * Drop & Sew™ Bobbin system
- * 2 StayBright™ LED lights
- * Auto tension
- * 13 Needle positions

ONLY
£199



BEST SEWING MACHINE BRAND



SINGER®

The world's favourite sewing machines

Join us on [Facebook](#) and [Twitter](#) @singersewinguk

www.singerco.co.uk

Big Vintage Sew-along news!

Have you joined in with the Big Vintage Sew-along yet? It's a fun opportunity for sewists to come together and 'sew vintage'. We're thrilled to have Rachel and Kate from The Fold Line to share all the news from the fun blogger tour. So who's been sewing up some vintage loveliness this month?



Follow the fabulous blogger tour, chat with your favourite sewists and see pattern reviews at www.thefoldline.com/blog

In March, The McCall Pattern Company in the UK chose 20 of its most popular vintage patterns from Retro Butterick, McCall's archive collection and Vogue patterns for the sew-along. A contribution from every vintage pattern sold in the inspirational edit will go towards supporting The Eve Appeal charity. Find out how to take part, plus read all about upcoming events and competitions at www.vintagesewalong.co.uk

Kate and Rachel say: "What better way to get inspiration for your own vintage outfit than to see what your favourite sewing bloggers are making? There is a fun-packed year with bloggers taking it in turns to make one of the 20 vintage patterns and each month we will be sharing their amazing outfits with you. This month it was the turn of Kerry Patterson (www.kestrelmakes.com), Fiona Parker (www.chainstitcher.blogspot.co.uk), Karen Ball (www.didyoumake.that.com) and Laura Clarke (www.sewforvictory.co.uk).



Kerry chose to make the 1960s Retro Butterick 5748

Kerry hosts the #VintagePledge during July with Marie Koupparis of the blog A Stitching Odyssey (www.astitchingodyssey.com). The pledge encourages you to sew using your vintage patterns so Kerry chose this dress as part of her pledge as well as for the Big Vintage Sew-along blogger tour. Although a 1960s pattern, the dress she chose has a very 1950s feel to it with full skirt, fitted bodice and scooped neckline details.

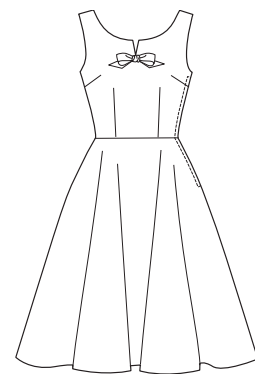

Kerry was so pleased with her dress that she has already worn it to two weddings and even taken it to a Parliamentary reception at the House of Lords! Kerry made her dress using multi-coloured watercolour cotton sateen. For a softer silhouette, she only lined the bodice rather than the whole dress and finished the hem above the knee for a more modern look. It is the classic party dress and every vintage fan should have one in their wardrobe! www.kestrelmakes.com/2016/07/watercolour-palette-dress-for-butterick.html



Karen decided to make the Retro Butterick 5880.

It is a 1950s dress lined with a loose fitting bodice, notched neckline and semi-fitted skirt with a side ruffle. Karen made two toiles to fit the bodice and then a further toile of the whole dress to get the perfect fit. She loves the style of the dress, particularly the neckline detail and found it very comfortable to wear.

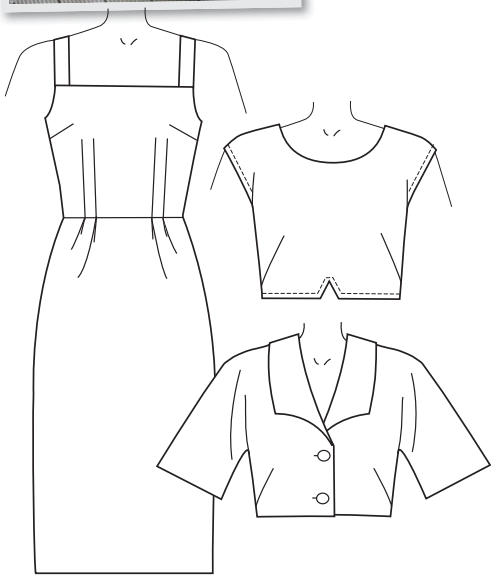
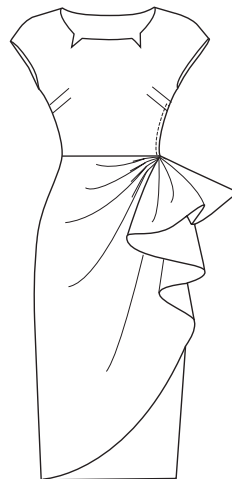

Fiona chose to make the 1960s Vogue 9082, which comes with dress, crop top and jacket variations. Fiona decided to make the dress with the additional crop top, finishing the hem above the knee to give the whole outfit a contemporary look. She made her outfit using an unusual structured barkcloth-type cotton, which gives a modern but classic look and a boxy shape to the crop top.

The dress has some lovely vintage details including facings throughout (so all the edges have a neat finish), lots of darts for an all-over good fit plus waist stay and lapped zip. Fiona fully embraced the vintage sewing process, following the instructions to challenge herself with new techniques and methods. The result is a stunning outfit that has been carefully made and is sure to be treasured! www.chainstitcher.blogspot.co.uk/2016/07/big-vintage-sew-along-reveal-vintage.html



Laura challenged herself to make Vogue 9127

from 1939. This dress has lots of vintage details including panels for structure, decorative stitching and a button front opening. Laura wanted to highlight the decorative details and panelling so she used a contrasting piping along the seams. The effect is fantastic – the red and blue crepe fabric really shows the design details of this dress.

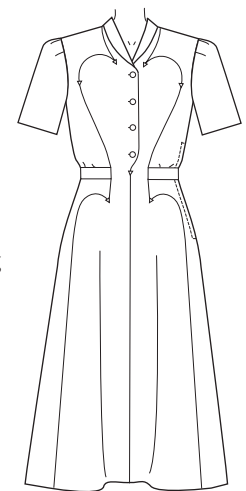

Laura decided to embrace the full vintage look; she added her own shoulder pads and used hook and eyes in place of a zip. Although Laura has only been sewing for a year and found this dress a challenge to make, she took her time to fit all the panels and learnt lots of new techniques along the way. The result is an authentic and striking outfit that would be the envy of any vintage fan! www.sewforvictory.co.uk/2016/08/05/big-vintage-sew-along-my-make/



A magical display of light and movement!



The first-of-its-kind World of **Disney** Christmas Tree

Over the years the beloved Disney characters have given us countless gifts... unforgettable moments of love, laughter and sheer joy. Now the magic of Disney delivers all the cheer of the festive season every day of the year, with the exclusive 'Wonderful World Of Disney' Illuminating Christmas Tree.

Crafted from the illustrations of Disney's own artists!

This magnificent sculptural tree is a must-have market-first featuring:

- 4 levels of rotating movement:
 - two separate moving trains
 - a parade of dancing princesses and dashing princes
 - Mickey in his sleigh rotating above the Disney Magic Castle
- 20 colourful LED lights illuminating ten handcrafted, handpainted scenes
- Over 50 Disney handsculpted figurines
- A medley of heartwarming Christmas carols at the flick of a switch!

Authentic Disney quality & superb value!

This handcrafted masterpiece can be yours for 6 interest-free instalments of only £29.99 – that's just £179.94 (plus £9.99 S&H)*. Don't wait to reserve yours... High demand is expected from Disney lovers and collectors Our 365-day guarantee assures 100% satisfaction. **Pay nothing now!** Just complete and return the Reservation Application today!

PAY NOTHING NOW

THE BRADFORD EXCHANGE RESERVATION APPLICATION

Please Respond Promptly

To: The Bradford Exchange Ltd, PO Box 653, Stoke-on-Trent ST4 4RA

YES! Please reserve (Qty) of the Wonderful World Of Disney Christmas Tree for me as described in this advertisement. I need **PAY NOTHING NOW!**
Complete today or Call 0333 003 0019

Name (Mr/Mrs/Miss/Ms)..... (PLEASE PRINT)

Address.....

Postcode..... Telephone.....

Mobile.....

Email Address.....

Applicants must be aged 18 years of age or over. UK mainland addresses only. Please note, we may contact you via email and mobile with information about your reservation and other relevant offers. From time to time, the Bradford Exchange may allow carefully screen third party companies to contact you. Please tick the boxes if you do not wish to receive such communications by: Email Telephone/Mobile Third Party Companies

Order Ref:P331462

The tree plays a medley of famous Christmas tunes!

IMPRESSIVE SIZE
Measures nearly **1 1/2 Feet Tall**

4 LEVELS
of rotating movement



AND IT LIGHTS UP!



Every detail is intricately painted by hand!

Shown smaller than its impressive actual size of approx. 16 inches in height! Powered by AC Adapter (included) or 3 x 'AA' batteries (not included).



The Wonderful World of Disney Christmas

© The Bradford Exchange. ©Disney. Based on the "Winnie the Pooh" works, by A.A. Milne and E.H. Shepard. All rights reserved. * S&H - Service & Handling. A credit check may be carried out by a licensed Credit Reference Agency. Offer applies to the UK only. Our guarantee is in addition to the rights provided to you by consumer protection regulations. 14-00567-001 U

Fastest way to order
www.bradford.co.uk

Call our 24hr hotline
0333 003 0019

In the search box, please enter DISNEY TREE Quote reference code P331462

Simple
sew



THE SHANNON

collection

This fabulous pattern pack includes your new staple **jersey dress and top pattern** plus stylish **wide-leg sailor trousers** and **preppy nautical shorts** all in **sizes 6-20**. The pull-on dress and top features grown-on sleeves with sleeve and neckline bindings, and a topstitched hem. The wide leg trousers have slash pockets, a side zipper and sewn-on buttons, plus the shorts have rolled-up hems

The dress and top can be made in both cotton and viscose jerseys, and even ponte de roma knit for a warmer version



DRESS

We used:
Red Anchors Away on White
cotton jersey, £10.95 per metre,
www.girlcharlee.co.uk



EXPERT ADVICE FROM COLETTE

Alyson Clair is a knitwear designer and the author behind the Colette Guide to Sewing Knits. We asked her to share her top tips on choosing the right needle for your jersey project

A willingness to play with fabric and try new things will take you far when it comes to sewing knits; it did for me. Let me help you select the correct size and type of needle for your project.

If you use the incorrect needle with your knit project, bad things can happen. For example, the needle may puncture your fabric, leaving a bunch of little holes, instead of going between the fibres. There is no way to fix the holes, so select your needle wisely.

Not only can the wrong needle cause puncture holes, but in the worst case, it can actually cause the fabric to run! There is no fixing that problem other than starting over, or taking in your seams quite a bit. A little extra caution when choosing your needle can save you from destroying garments before they are even worn.

Using a needle that is too large can also cause fabric to be 'eaten' by your machine. Instead of puncturing the fabric, the large needle just shoves it down into the machine. On the opposite end of the spectrum, a needle that is too small can cause your thread to break.

Knits can be an entirely new game, but it's the only one I want to play. I hope you enjoy creating with knits as much as I do.



TOP

We used:
 Aqua blue film
 grain roses cotton
 spandex jersey,
 £9.95 per metre,
www.girlcharlee.co.uk

Save an
 incredible
20%
 at www.girlcharlee.co.uk
 using the code
LOVE31
 until 5/10/16

*The trousers and
 shorts will work in any
 medium-weight woven
 like cotton twill, denim,
 and linen*



SHORTS

We used:
 Dark blue 4oz
 lightweight denim
 fabric, £8.99 per metre,
www.abakhan.co.uk
 Gold metal anchor
 blazer buttons size
 32 (20mm), £1.10 each,
www.abakhan.co.uk

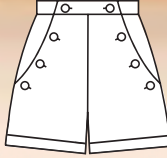

TOP TROUSER TIPS

Sewing trousers can be intimidating at first, so we've pulled together some helpful advice to make your project smooth sailing

It may sound obvious but you should always choose your trouser length while wearing the shoes you plan to pair with them. This will get a better feel for how the trousers actually hang on you and will ensure a proper length hem.

Wide-leg jeans and trousers and extreme flares look best with a longer length. You almost want your shoe hidden; the back of the trousers or jeans should be ¼" off the floor. This will keep them from dragging but give a modern, clean look. Only a peek of toe should show.

TROUSER FITTING RESOURCES

Learn to Fit with Melissa Watson: McCall's M6965 Wide-Leg Pants

This three-part tutorial is completely FREE on the McCall's YouTube channel and is presented by Melissa Watson, McCall's designer and certified sewing instructor for the Palmer Pletsch tissue fitting method. See the full series at www.youtube.com/user/mccallpattern

The Colette Patterns pants fitting cheatsheet

We love that Sarai Mitnick, founder of Colette Patterns, has managed to distil most of the trouser adjustments you might need down into an easy-to-scan format so you can identify the fit problem you're facing and learn the adjustment you need to make. See the full list at blog.colettehq.com/tutorials/the-colette-patterns-pants-fitting-cheatsheet

The Sew Over It Ultimate Guide to Sewing and Fitting Trousers

Follow a trouser sew-along with Lisa Comfort, the smart cookie behind Sew Over It patterns, shops and books. Choose between two styles of trouser patterns, work through the Fitting Surgery and achieve a polished finish. sewoverit.co.uk/online-classes/ultimate-guide-sewing-fitting-trousers

TOP

We used:
Tri black and white organic jersey, Elvelyckan Design, £8.50 per half metre, www.mauds-fabric-finds.com



TROUSERS

We used:
Red linen cotton blend fabric, £10.50 per metre, www.truofabrics.com
Metal blazer button Gold (20mm), 80p each, www.abakhan.co.uk



Sewing & Quilting Summer Offers!



Innov-is V5

Advanced sewing, quilting and embroidery machine

Enjoy the versatility of this advanced sewing and embroidery machine. Create beautiful projects with intricate decorative stitches and stunning embroidery.

- Fast 1050 stitches per minute embroidery speed
- Extra-large long arm - 11.25" (285mm)
- Colour LCD touch screen
- Large 300mm x 180mm embroidery area



FREE
PE-Design
10 worth
£999

£2,999

Innov-is 800E

Embroidery only machine

Add beautiful embroidery to your projects quickly and simply. The intuitive controls, large work space and embroidery area make this an ideal addition to your sewing room.

- Embroidery only machine
- 260mm x 160mm embroidery area
- 138 built-in embroidery patterns
- Colour LCD touch screen
- Quick-set bobbin
- Automatic needle threader
- 11 built-in fonts



Save £300
usual price
£1,299

£999

Innov-is 1100

8.3" Long arm sewing and quilting machine

Extra-large work space combined with the strong, smooth and quiet feed system make the Innov-is 1100 ideal for all types of sewing from fashion to quilts.

- 140 built-in stitches excluding lettering
- 5 Styles of lettering
- 10 Styles of automatic 1-step button holes
- SFDS - Square Feed Drive System
- Combine and memorise stitches
- Automatic thread cutter



FREE
Creative
Quilt Pack
worth £149

£749

Innov-is 35

Sewing machine

Computerised sewing machine packed with user friendly features such as easy jog dial stitch selection and one touch needle threading.

- 70 stitches
- 7 styles of automatic 1 step button holes
- Advanced automatic needle threader
- Variable stitch length and width control
- Start/Stop button
- Twin needle setting



FREE
Creative
Quilt Pack
worth £149

£399

UK Dealer List

Scotland

David Drummond Edinburgh EH12 5HD 01315 397 766
The Sewing Machine Shop Fochabers IV32 7DU 01343 823 961
Karella House Ltd Aberfeldy PH15 2LS 01887 822 027
Pembertons Sewing Machines Stirling FK8 1HA 01786 462 993

North East

Singer Sewing Centre Whitby Bay NE26 2SY 0191 2525 825
Tullys Sewing Machines Sunderland SR1 3JG 0191 5657 995
The Fat Quarters Newcastle upon Tyne NE17 7TN 01207 565 728

North West

Affordable Sewing Machines Ltd Moreton CH46 9AQ 0151 677 7755
Bamber Sewing Machines Ltd Eccles M30 7HY 0161 707 7786
Hobkirk's Sewing Machines Ltd Blackburn BB2 2AJ 01254 693 555
Hobkirk's Sewing Machines Ltd Bury BL9 0LQ 0161 764 4450
Jaycocks Chester CH1 4LT 01244 394 099
Lord's Sew Knit Centre Accrington BB5 3DE 01254 389 171
M&S Sewing Machines Heywood OL10 4NN 01706 386 943
R&T Machines Blackburn BB1 2AL 01254 520 63
Temptations Bentham LA2 7HQ 01524 261 868
Sewing Machines Direct Wrexham LL12 0PJ 0800 092 5215

Yorkshire & The Humber

Gillies Fabrics York YO1 8SW 01904 626 244
Grimsby Sewing & Knitting Grimsby DN32 9DR 01472 343 921
Woodseats Sewing Machines Ltd Sheffield S8 0RY 0114 255 2822
Sewing Machines and Crafts Keighley BD21 1AD 0153 560 9466

Midlands

Brewers Sewing Machines Wolverhampton WV2 3AF 01902 458 885
Couling Sewing Machines Lincoln LN5 8AW 01522 521 841
Creative Hands 2 Worcester WR1 2LU 01905 249 40
DC Nutt Sewing Machines Walsall WS3 3SS 01922 497 603
Grain Sewing Machines Ltd Nottingham NG6 8UY 0115 927 1155
Frank Nutt Sewing Machines Birmingham B14 7AA 0121 443 3978
GS UK Ltd Nottingham NG2 3DE 0115 844 8000
Leamington Spa Sewing Machines Ltd CV32 4RA 01926 427 572
The Lorna Knight Sewing Academy Leek ST13 7NX 01538 371 682
L & M Nutt Sutton Coldfield B73 5BS 0121 373 5497

East Anglia

BSK Ltd Bedford MK41 7LE 01234 217 096
Franklins Group Limited Colchester CO2 7DU 01206 563 955
Franklins Group Limited Ipswich IP1 3EL 01473 221 188
Franklins Group Limited Chelmsford CM2 0LG 01245 346 300
Sewing Machine World Kings Lynn PE30 5DD 01553 773 362
Sew Northampton Northampton NN1 4DX 01604 637 200
Stitch X Stitch Stowmarket IP14 1HH 01449 257 077

Wales

Cliffords Sewing Machines Swansea SA1 3JY 01792 655 928
J&B Sewing Machine Co Ltd Newport NP19 4SY 01633 284 646
J&B Sewing Machine Co Ltd Cardiff CF11 8AA 02922 402 418
Sewing Machine Direct Wrexham LL12 0PJ 08000 925 215
Sewing Innovations Techsoft UK Ltd LL18 5TQ 01745 535 007

South East

C & A Supply Co Ltd Cranleigh GU6 8NE 01483 267 777
Brighton Sewing Centre Brighton BN1 1YD 01273 621 653
British Sewing Centre Boreham Wood WD6 1FJ 0208 236 1520
Dowlings Wickford SS11 8YJ 01268 570 248
Eastleigh Sewing Centre Eastleigh SO50 5LD 02380 650 808
Fareham Sewing Fareham PO16 0EH 01329 234 641
GTS Sewing Machines Banbury OX16 9PQ 01295 701 384
Hastings Sewing Centre Hastings TN34 1RE 01424 423 108
Lewisham & Deptford S/Mcs Ltd London SE8 3NT 02086 921 077
Maidstone Sewing Centre Maidstone ME14 1ED 01622 670 254
Regent Sewing and Knitting Ltd Ilford IG1 2AG 0208 4780 669
Rona Sewing Machines Waltham Cross EN8 7BX 01992 640 250
Sew Devine Reading RG6 1JQ 01189 268 664
Studio 48.50 Billerica CM11 2JD 01268 523 780
The Sewing Centre London SW11 3BP 0207 228 3022
The Sewing Shop Canterbury CT1 2HX 01227 457 723
Tysons Sewing Machines Limited Southall UB1 3DA 0208 5741 750
Wimbledon Sewing Machines Co. Ltd SW17 7AA 0208 767 0036
Woking Sewing & K/M Centre Woking KT15 3NY 01932 352 958
CCB Sewing Machines Rochester ME1 1HS 01634 841 597

South West

And Sew to Knit Taunton TA1 1NZ 07547 006 618
Caffle Crafts Weston Super Mare BS24 6SE 01934 838 327
Exeter Sewing Machine Company Exeter EX1 2LD 01392 275 660
Franklins Group Limited Salisbury SP2 7SU 01722 554 466
Sewcraft Swindon SN1 1SD 01793 536 778
The Sewing Studio Redruth TR15 2DB 01209 216 942
D & S Sewing Machines Newton Abbot TQ12 2BS 01626 369 840

Northern Ireland

Barry Peg BT14 1AB 028 9045 6014

Isle of Man

New Generation Port Erin IM9 6AQ 01624 836 301

The Dressmaker's diary

No one loves a pattern hack more than Elisalex de Castro Peake, head of design for By Hand London. In this issue she's turning the Shannon trousers into a stylish pair of dungarees!



In my world, 'sewing basics' can be loosely translated as, 'filling the gaps in my cocktail dress closet'. When I spend time on something, it had better be fabulous.

Maybe I've been overdosing on old episodes of *Sex & The City* lately, but I like to think of my attitude towards sewing as rather Samantha Jones-esque: basically – go all out, or go home. This same approach can be applied to sewing trousers (or anything at all). I've yet to go down the handmade jeans route simply because I already own a couple of great pairs of Levis, and I'm way more excited by the prospect of whipping up a swooshy pair of palazzo pants, or some blush pink needlecord flares (on my winter to-sew list – yippee).

Given the chance to try out and have a hack-around with the new Simple Sew pattern that would be coming out at the same time as my next column, I immediately began picturing a pair of wide-legged scarlet dungarees. And luckily for me, I managed to get my paws on some glorious bright red organic cotton canvas from Ray Stitch (thank you Rachel!), so I was good to go. The perfect trans-seasonal piece, dungarees can be styled up or down in so many ways – include as many bells and whistles as you like!

Elisalex
x

MATERIALS:

- ♥ The wide-legged trousers pattern pieces from the Simple Sew Shannon collection
- ♥ An extra half metre of your main fabric and half a metre of a contrasting lining fabric
- ♥ Two extra buttons to match the ones you're using for your trousers
- ♥ Paper, a pencil and ruler to draft your dungarees panel piece
- ♥ Your usual sewing tools and supplies

Let's begin by drafting our dungarees panel... In order to maintain the illusion that the trousers are front fastening, we want our dungarees panel to continue from the side front seams. To do this, we're going to use the Front Waistband pattern piece (Piece 9) to dictate the width of the dungarees panel where it meets the waist.



- 1 On a piece of paper folded in half, draw a line out from the fold using the top line of your Front Waistband piece as a guide.

Next, measure up along the fold however tall you want your dungarees panel to be (mine was 11") and, from that point, measure out and across to how wide you want your dungarees to be at the top. Remember your paper is folded in half, so you only need half of this measurement! Mine was 5½", so a total width of 11". At this point you could give the top line of your dungarees some shape – see how I chose to turn mine into a sweetheart neckline?

- 2 Connect the dungaree top with the waist with a vertical line and finally, add seam allowance all around, cut out your pattern piece and unfold.

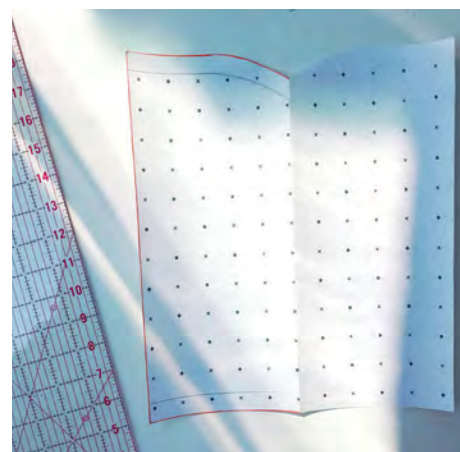

3 You'll need to cut one dungaree panel from your main fabric and one from your lining fabric.



4 Pin the two panels, RST along the top line and down each side, leaving the waist open. Stitch, then trim, grade, clip and/or notch your seam allowance as needed and turn to the RS and press.



5 To make the straps, cut four long strips of your main fabric that measure approximately 35x2" wide (this includes 1/4" seam allowance). Cut them either straight across or snip the ends into little points. Assemble your straps by stitching them RST with your 1/4" seam allowance, leaving one end open for turning through to the RS, or, if your fabric is rather sturdy (as my canvas was) you'll be better off pressing all the seam allowances in first, then top-stitching the front and back together.



6 Now we can get back to the making of the trousers. Follow your instructions up to Step 9 – you should have the bulk of your trousers done, minus one side seam, and your outer and inner waistband pieces assembled but not yet joined to each other.



Take your inner waistband and lay it out RS facing you, with the shorter curve along the bottom (upside down). Pin your dungarees panel to the waistband front panel – RS facing you, and pin your straps to the waistband back panel, ensuring that they are evenly spaced out either side of the centre back.

Place the outer waistband over the top, wrong side facing you, and pin it all into place, sandwiching your dungaree panel and the straps between the outer and inner waistbands. Sew in place and press the waistband pieces down. Looking good!

7 Now back to the trousers – continue from Step 11 and attach the waistband to the trousers, insert your zipper, finish the inner waistband and hem your trousers. Stitch your buttons into place along the pockets as indicated in the pattern.



8 Now the fun part! Try your dungarees on in order to figure out the perfect placement for your straps and sew buttonholes. Use the extra two buttons to anchor (pun intended!) your straps into place.



All done, and anchors away!



Ellen lace-up

BOAT TOP

Take inspiration from Ellen MacArthur and channel your inner sailor with this no-pattern, boxy short-sleeved top with V lace-up neckline

Project **FIONA HESFORD** Sewgirl
Photography **ALEX WRIGHT** teneight



Download
FREE
TEMPLATES

WE USED



Striped waffle knit (150cm wide), £11.99 per metre,
www.thefabricshops.co.uk

NOTES:

The finished length for all sizes is approximately 63cm, the finished width is 58 (S), 63 (M) and 68cm (L).

All seam allowances are 1cm unless otherwise specified

Finish all raw edges with a zigzag

Skill level ♥♥

MATERIALS:

- ♥ 1-1.5m 150cm-wide jersey fabric
- ♥ 30cm lightweight fusible interfacing
- ♥ 6 5.5mm eyelets
- ♥ 1m cord
- ♥ water-soluble pen or tailor's chalk
- ♥ large dinner plate or curved tailor's ruler

CUTTING & SIZING:

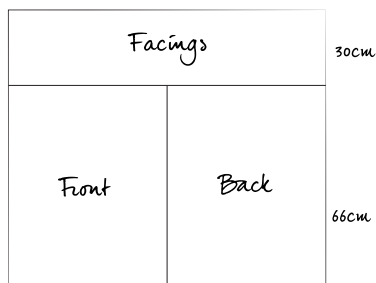

Cut two pieces for the front and back as follows:

- Small: 60x66cm
- Medium: 65x66cm
- Large: 70x66cm

Cut one front neck facing and one back neck facing on the fold in main fabric and interfacing, following the template markings

DIAGRAM 1:

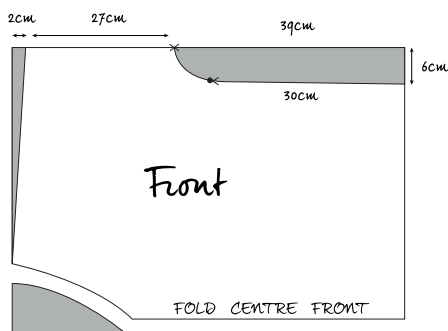
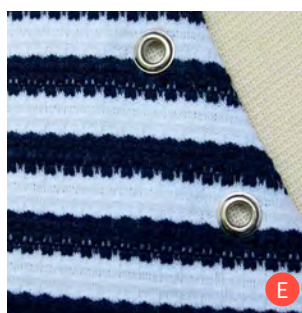
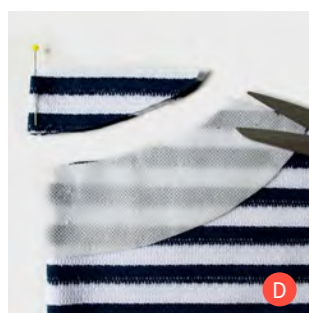
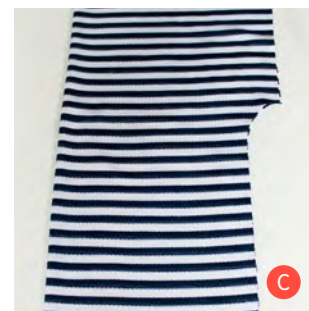
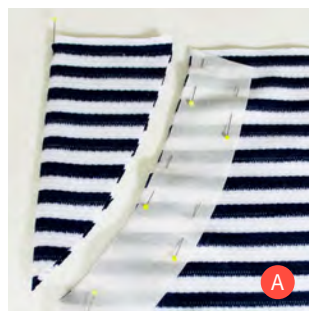
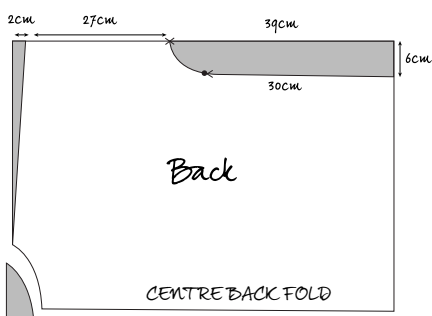

DIAGRAM 2:



How to make:

CUTTING DIRECTIONS

- 1 Fold your front piece exactly in half widthways with the RST and press. Make sure your fabric piece is the right way up. Pin together at sides.
- 2 Place your neck front facing at the top edge and line up to the fold as indicated on the template. Pin then cut a V neckline following the inner edge only. (See Pic A.)
- 3 Mark a point with a pin or water-soluble pen at the top side edge 2cm down from top edge. Draw a line with a ruler to meet the V neckline. Trim along this line to make the shoulder line. (See Pic B.)

4 You may want to refer to Diagram 1. At the unfolded edge, mark a point at 6cm in from the side at the lower edge and 39cm up at side edge. Extend a line from the 6cm marker point up vertically by 30cm.

5 From this point make a curved line to meet the 39cm marker point using a large dinner plate or curved ruler. Trim this section along the line. (See pics C and D.)

6 Repeat for the back piece using the back facing template. Trim shoulder seam and side seam in the same way as front, and follow Diagram 2. (See Pic E.)

ASSEMBLY

- 7 With RST, join the front to the back at the sloped shoulder seams with a 1cm seam allowance. Finish the raw edges. Press seam towards the back piece.
- 8 Iron the interfacing to the WS of each facing

piece. Join the front and back facings RST at the shoulder seams. Press seams open.

9 Fold over and stitch a small 6mm hem on the outer edge of the assembled facing.

10 Pin to the assembled bodice at the neckline with RST aligning the seams. Pin, and then sew a 1cm seam all around.

11 Clip the V-neck point at the centre front, taking care not to snip the stitching line. (See Pic F.) Under stitch the seam allowance to the facing. Fold the facing back to the inside and pin in place temporarily. Stitch in the ditch along the shoulder seams to secure the facings in position.

LACING

12 Mark the three eyelet positions on left and right side of the V-neck with a water-soluble marker, taking care to keep them parallel. Insert the eyelets following the manufacturers instructions. Alternatively, make small 5mm buttonholes at each marker point. (See Pic G.)

FINISHING

13 Starting 10cm up from the lower edge (for the side vents), join the front to back at the side seams with the RST. Finish the raw edges. Notch the curved seams under the armhole if needed.

14 Finish the raw lower edge of the front and back. Fold over and stitch a 2cm hem on the lower edge. Top-stitch the side vent opening at each side, pivoting at the corners.

15 Finish the raw edge of the armhole. Fold over and sew a 1cm hem. (See Pic H.) Feed the lacing through the eyelets to complete!

Get on board 4 EASY NAUTICAL STYLES TO TRY

THE BRETON REVISITED

Channel your inner Bardot but clash your stripes by using contrasting colours and sizes. For a modern twist, mix in a pop of floral along a bias-edge trim.



We love these perfectly co-ordinating Campon stripes in small and large scales of aqua, berry, purple and grey cotton jersey, priced £14.90 per metre, from www.dragonflyfabrics.co.uk

Lavish Pretty Ditsy Dream jersey from Art Gallery Fabrics (AGFLAH16807K). See www.hantex.co.uk/mystockist for your local retailer

Scared of the crop top trend? Make a matching shell top to wear over a dress that buttons at the back, and create the illusion of two garments without the risk!

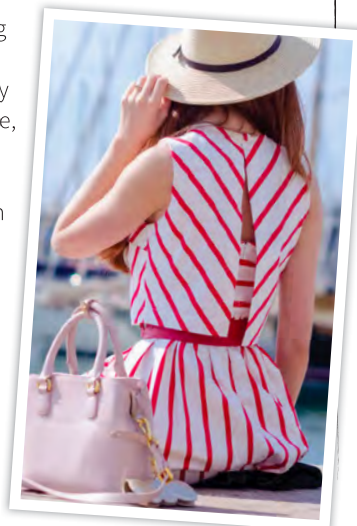

REGATTA STYLE

Whether or not you're a 'boatie', there's plenty of inspiration to be found by the waterfront with linen, chambray, and chino garments.



Preppy fashion was never so much fun as with a seersucker blazer. You'll love Butterick 5926 in anchor-print seersucker stripes from Robert Kaufman, £4.50 per FQ, www.eternalmaker.com



We can't get over the idea of using the tutorial on page 28 to create a lace-up dress using this eco-friendly light blue handwoven crossweave cotton, £16.40 per metre from www.offsetwarehouse.com

Whether you picture yourself aboard a fabulous yacht or as a modern day mermaid, find your perfect style with our handy round-up of the top four nautical trends to sew yourself

Check out our Nautical Pinterest board for plenty more inspiration - uk.pinterest.com/lovesewingmag

MODERN MERMAID

Whether you prefer a structured dress or a floaty jumpsuit, think classic garments in shell and coral pink, or aqua and seafoam green.



Seafoam swirls, Round Elements, available in cotton (AGFROE305) and jersey (AGFROE305K) from Art Gallery Fabrics



Swanlings Bevy peach, Hello Ollie, available in cotton (AGFHOL46650) and jersey (AGFHOL46650K) from Art Gallery Fabrics

The Scoop Neck Dress pattern number 07/2012 #139 comes in plus sizes, and is just £3.99 as a PDF download from www.burdastyle.co.uk

Sew a frill-front camisole with *The Great British Sewing Bee: Fashion with Fabric* project book by Love Sewing columnist Claire-Louise Hardie, £25 www.quadrille.co.uk

These sweet prints from Art Gallery Fabrics will work in your wardrobe or your home. See www.hantex.co.uk/mystockist for your local retailer.

RIVIERA CHIC

This unofficial uniform falls somewhere between nautical and Parisian chic but manages to look effortless and breezy in block primary colours and stylish details.



Pair your wide-leg trousers with handmade espadrilles using Prym's range of soles, threads and tools that can be paired with almost any fabric to create custom footwear. Follow the excellent tutorial by Lauren Guthrie at www.guthrie-ghani.co.uk/blog

Complete your outfit with a charming Riviera Suitcase handbag, £32 from uk.accessorize.com

The pattern hacker in us can't sit still thinking about using this Sass & Belle oversized rickrack in turquoise on a skirt. Buy a 3m roll for £3.99 from www.higgsandhiggs.com

Yes! I would like to subscribe to *Love Sewing* and receive Matt Chapple's *Make It Own It Love it*

Please complete in ballpoint pen and send to:
 Love Sewing, Tower House, Sovereign Park,
 Market Harborough, Leicestershire LE16 9EF

Quote code:
 PLSE0916

Your details

TITLE:..... FORENAME:.....
 SURNAME:.....
 ADDRESS:.....
 POSTCODE:.....
 DAYTIME TELEPHONE:.....
 MOBILE TELEPHONE:.....
 EMAIL:

To give a subscription as a gift, please complete the section above and supply the recipient's address details on a separate sheet.

DIRECT DEBIT @ £26.47 EVERY 6 MONTHS **SAVE 32%**

Instruction to your Bank or Building Society to pay by Direct Debit



Name and full postal address of your Bank or Building Society:

To: The Manager Bank/Building Society
 Address
 Postcode

Name(s) of Account Holder(s)

Branch sort code Bank/Building Society account number

Office use only
 Reference
 Originator's Identification Number 4 3 9 3 4 5

Signature Date

Please pay Practical Publishing Int Ltd Direct Debits from the account detailed in this instruction subject to safeguards assured by the Direct Debit Guarantee. I understand that this instruction may remain with Practical Publishing Int Ltd and, if so, details will be passed electronically to my Bank/Building society. Bank and Building Societies may not accept Direct Debit instructions for some accounts.

£52.99 FOR 13 ISSUES - CHEQUE/ POSTAL ORDER/DEBIT/CREDIT CARD

I enclose a cheque/postal order made payable to Practical Publishing International Ltd OR please debit my Visa/Mastercard/Maestro (delete as appropriate)

CARD NUMBER

EXPIRY DATE ISSUE NUMBER (if Maestro)

SIGNATURE:.....DATE:.....

*UK offer only. Minimum subscription term is 12 months. Subscription starts at the next available issue. We reserve the right to request the gift is returned should the subscription be cancelled early. We reserve the right to send an alternative gift should the Matt Chapple's *Make It Own It Love It* book become unavailable. Please note delivery could take up to 4 weeks. For overseas rates and other payment methods please visit: www.moremags.com/subscriptions. Hurry, offer expires 06/10/2016.

I DO NOT want Practical Publishing Int Ltd to contact me by email telephone post
 Tick this box if you do not wish to receive promotional material from carefully selected third-party companies

Invest in your creativity today - subscribe and save £24.93 on the cover price!

Love Sewing is fresh, fun and full of fabulous projects and guides to keep you inspired for months to come. Leading the way with a broad range of styles and ideas, *Love Sewing* will help you make your very **own unique garments, gorgeous homeware, chic accessories and a multitude of projects for children**, all with the support of our experienced and passionate Design Team.



Why subscribe?

- Save money on every issue
- Never miss an issue
- Free delivery direct to your door
- Be the first to read *Love Sewing*
- Every issue includes a **FREE** pattern
- PLUS free access to The VIP Lounge - exclusive offers, projects, downloads and more!



Exclusive subscription offer

FREE copy of Matt Chapple's book *Make It Own It Love It* when you subscribe to *love Sewing**

Written by the winner of BBC2's
The Great British Sewing Bee 2015!

Save 32%
Just £26.47
every 6 months

DIRECT
Debit



Join *Love Sewing* today and we will send you a copy of *Make It Own It Love It* by Matt Chapple. Focusing on making sewing easy and fun, the book explains the basic kit needed along with step-by-step instructions on how to make projects such as a beautiful box-pleated skirt and adding bias binding to pocket edges for a splash of colour.



Ordering is quick and easy...

Online: www.practicalsubs.com/1111

Call: **01858 438899** (Quote code: PLSE0916)

Hurry, this offer expires 06/10/2016

MY PATTERN PICKS

Rosabella Riddington



Rosabella, of the YouTube channel Sewn, inspires thousands of sewists with her weekly sewing vlogs as she continues to build her handmade wardrobe on a budget. We asked Rosabella to share the on-trend sewing patterns she loves this month

SEW OVER IT ULTIMATE TROUSERS

I was very nervous embarking upon this project as I had not made slim-fitting trousers before but the Ultimate Trousers sew up beautifully. Lisa Comfort has a brilliant video on YouTube demonstrating how to add a waistband, which I watched to help me with this project. If you haven't yet, make sure you check out her brilliant sewing vlogs too!



NEW LOOK 6224 & 6123

This gorgeous fabric was bought back for me as a souvenir from Italy by my boyfriend's mum Adela and I knew it had to be turned into a gorgeous, flouncy frock. I combined the bodice from New Look 6123 with the sleeves and skirt from New Look 6224 to get the exact look I wanted. I also used the skirt of New Look 6123 to make bridesmaid dresses for my friend Maria's wedding last summer. Don't be afraid to mix and match pattern pieces to get the dress of your dreams!

FIND OUT MORE

Rosabella is a reception class teacher from South West London and was taught to sew at a young age by her mum. To see more of her latest sewing makes and tutorials check out Rosabella's YouTube channel www.youtube.com/c/Sewn You can also view her blog at www.fancyfrugality.blogspot.com and follow her sewing experiences on Instagram

SIMPLICITY 2444

I often look for sewing inspiration on the high street and try to incorporate trends I like into my handmade wardrobe. Having seen lots of lovely Bardot-style dresses, I decided to have a go myself with this pattern. It's got a gorgeous cape collar, which gives the look of an on-trend off-the-shoulder dress without requiring a strapless bra. I used stretch cotton printed with lemons for a super summery vibe.



TILLY AND THE BUTTONS AGNES TOP

This is the pattern I credit with giving me the confidence to sew with jersey. You cannot beat Tilly's gorgeous patterns and detailed step-by-step instructions. I'm currently working on hacking this top into a T-shirt dress. Wish me luck! The skirt I'm wearing is New Look 6346.



KWIK SEW 4015

This anorak pattern is a favourite of mine and I just love how easy it is to throw on over a handmade dress on cooler days. Living in London, a raincoat is an absolute essential and I believe there's no reason why practicality and style can't mix.

NEW LOOK 6446

I fell in love with this new pattern from New Look as soon as I saw it and stitched it up in lovely soft-washed denim; perfect for a day at the seaside! This jumpsuit looks great on its own or layered with a striped tee on cooler days.



WE USED



Turquoise stretch
denim, £9.99 per metre,
www.higgsandhiggs.com

Ship-shape SKIRT

This quick-to-sew skirt is a figure-flattering A-line shape and the double row of covered buttons on the front mean sailor chic is within your reach

Project **CLAIRE GARSIDE** Simple Sew
Photography **ALEX WRIGHT** teneight



Download
FREE
TEMPLATES

NOTES:

Finish the raw edges with a zigzag stitch or on an overlocker

Skill level ♥♥

MATERIALS:

- ♥ 1-2m medium weight woven fabric like cotton or denim
- ♥ 50cm medium weight fusible interfacing
- ♥ 6 covered buttons
- ♥ covered button tool
- ♥ 9" concealed zipper
- ♥ co-ordinating thread
- ♥ templates downloaded at www.love sewingmag.co.uk

CUTTING:

45"-wide layplan

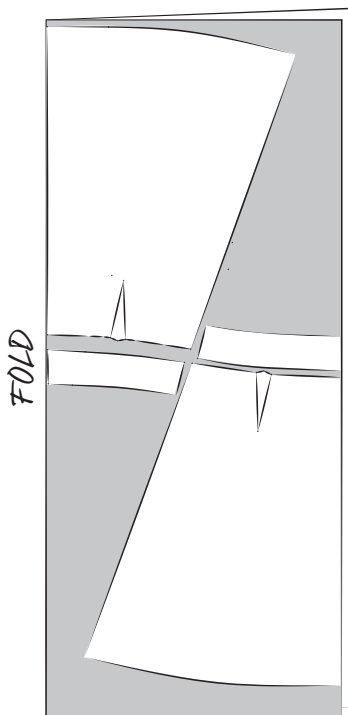

60"-wide layplan

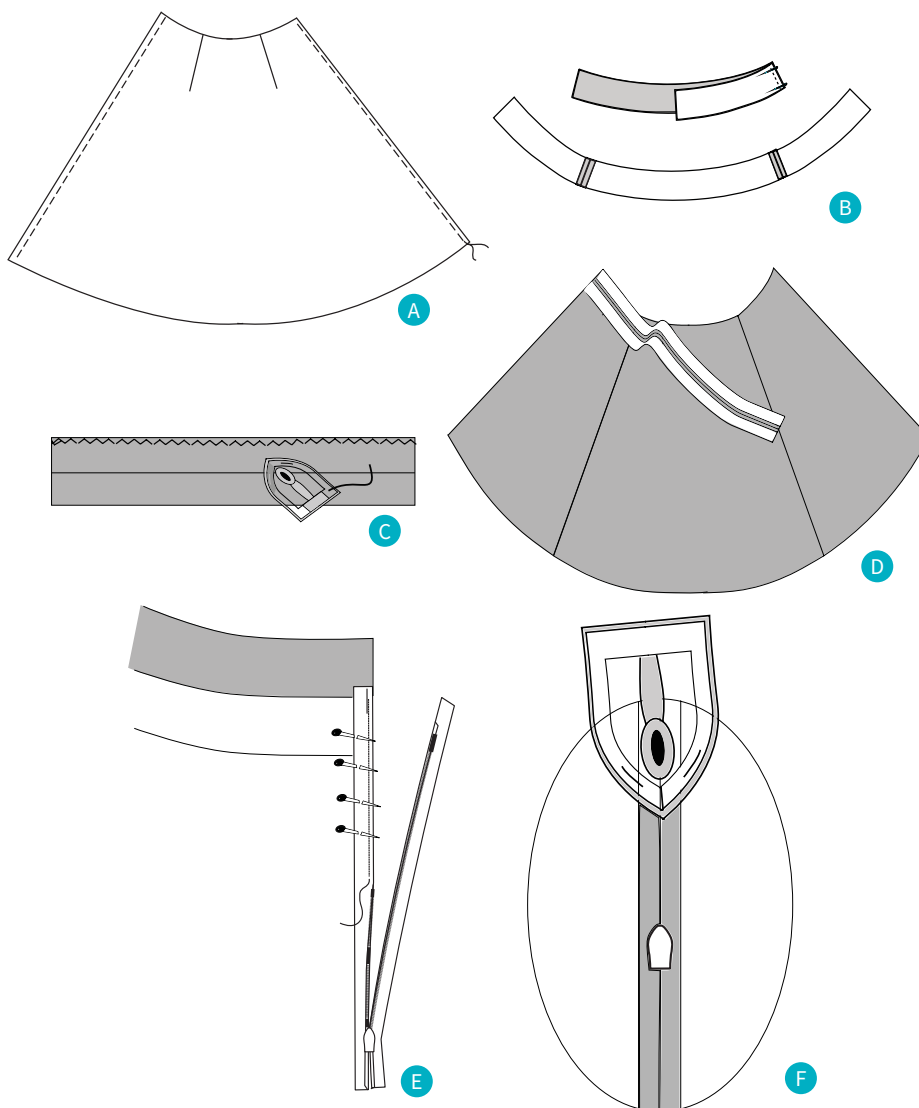
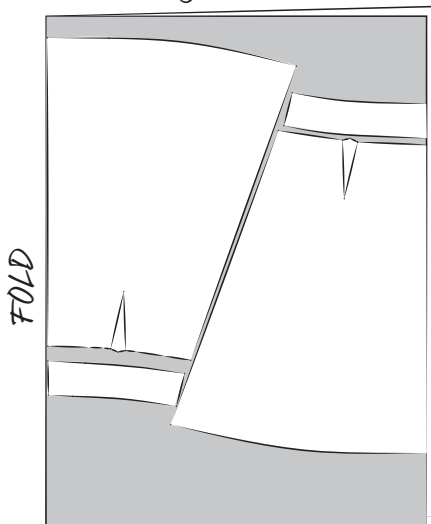

SIZING:

Finished garment measurements	6	8	10	12	14	16	18	20
Waist	25"	27"	29"	31"	33"	35"	37"	39"
Hem circumference	61"	63"	65"	67"	69"	71"	73"	75"
Length including waistband	24"	24"	24"	24"	24"	24"	24"	24"

How to make:

- 1 Sew darts in front skirt, press towards side seams.
- 2 Sew darts in back skirt pieces and press towards side seams.
- 3 With RST attach front skirt to back skirt pieces at the side seams using a 1.5cm seam allowance. Press seams open. (See Pic A.)
- 4 Assemble the waistband by sewing two back waistband pieces to one front at the side seams RST and using a 1.5cm seam allowance. Press the seams open. Apply interfacing to the

second set of waistband pieces and assemble as before. This will now be referred to as your waistband facing. (See Pic B.)

- 5 Pin your waistband and facing RST and sew along the upper edge using a 1cm seam allowance. Press the seam open. (See Pic C.)
- 6 With RST pin the lower edge of your waistband to the skirt and sew in place using a 1.5cm seam allowance. Press the seam allowance upwards. (See Pic D.)
- 7 Keep the waistband up so it is out of the way and pin the zipper in place along the CB,

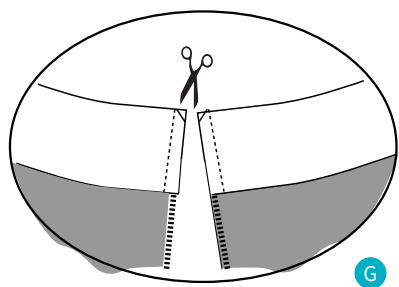

G

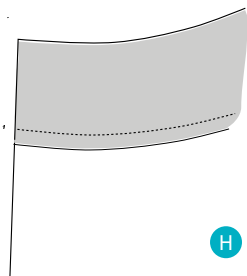

H

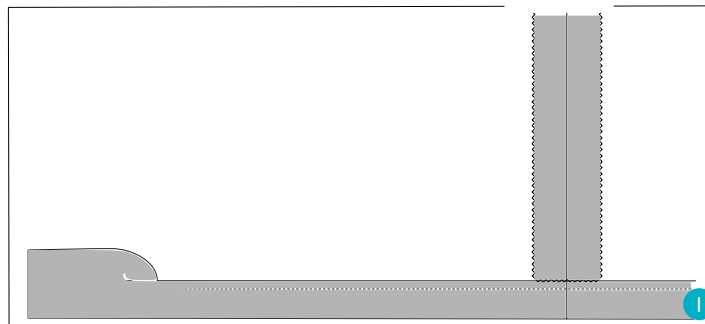

I

making sure the top of the teeth sit just below the seam where the two waistbands are joined. Hand-tack to secure, then change to zipper foot and sew in place. (See Pic E.) Repeat for the other side, being sure to align the waist seam.

8 Finish the CB seam by turning skirt WS out and continuing from the base of the zipper down to the hem. Press seam open. (See Pic F.)

9 Press up the lower edge of the waistband facing by 1cm. Flip over the waistband facing so it is RST with the outer waistband and covers the top of the zipper. With the zipper foot in place, make a line of stitches down the sides of the zipper tape. Clip corners to reduce bulk. (See Pic G.)

Top tip!

For a perfectly aligned seam across a zipper, sew one side then hand-baste the zip on the other just at the seam position so you can quickly close the zip and test the placement before sewing on your machine

10 Turn the waistband and facing through to the RS and use a point turner to achieve a neat corner at the top of the zip. Pin the lower edge of the waistband facing in place from the RS. There should be a slight overhang past the seam on the inside. Stitch in the ditch by sewing on the RS of the skirt, along the crease of the waistband seam as slowly as your machine will let you. On the inside you'll see a visible row of stitching where the waistband facing has been stitched down. (See Pic H.)

11 Finally press up your hem according to hem allowance, pin in place and then stitch removing pins as you go. (See Pic I.)

TUTORIAL

Covered buttons

1 Using the template on the back of your button kit, trace a circle onto the fabric.

2 With a threaded handsewing needle, loosely baste a gathering stitch a few mm in from the outer edge of the circle, all the way around leaving long threads loose. Place your button top face down on top.



3 Place the lower half of the button mould on your work surface and centre the fabric circle and button top over the opening.

4 Using your fingers, gently push the button shell down into the mold. The fabric should gather up around the button shell like a little pouch.

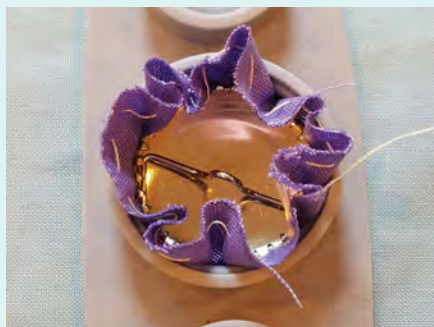

5 Draw the fabric into the button shell tighter using the gathering stitches and cover with the button back.

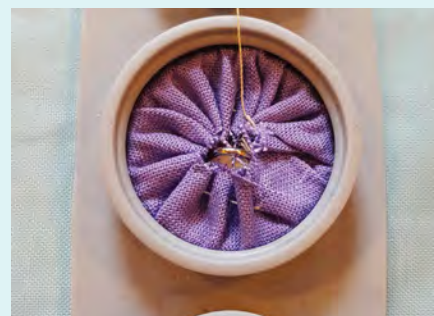

6 Place the top part of the mould on top of the button back and firmly push the button back into place. The entire top will push down into the lower mould. You can usually hear a small pop when the back seats against the shell.



7 Carefully remove from the mould and you're ready to attach to your skirt!

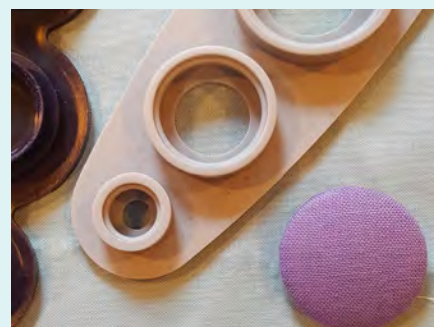

If using a lightweight fabric you may find it best to interfacing your fabric circle.



Liberty pop

SCALLOP POCKETS

*Turn a simple patch pocket into a stylish eye-catching design feature
using your Liberty scraps and this easy tutorial*

Project & photography **ASHLEY CRAMP** Lazy Daisy Jones



Why not add a scallop pocket to the A-line skirt project on page 37?! It would easily work on an apron, bag or shift dress too

Skill level ♥

MATERIALS:

- ♥ square graph paper
- ♥ 16cm-square main fabric for the pocket outer
- ♥ 16cm-square scraps of fabric or a FQ of your favourite print for the pocket contrast
- ♥ co-ordinating thread for main fabric

How to make

- 1 Using square graph paper, draw out the desired finished pocket size, adding a 1cm seam allowance. Alternatively you can trace a simple patch pocket from another pattern.
- 2 Add an extra 2cm to the top of the template and draw scallops above using the squares to keep your design accurate. The scallop edge will be turned down once complete.
- 3 Cut out a pocket in a plain fabric and a pocket in a contrasting print. (See Pic A.)
- 4 Pin RST and sew around each edge, leaving an opening at the bottom for turning through. Trim and clip corners and notch top of scallops. (See Pic B.)
- 5 Press both the assembled pieces flat and turn inside out. Fold the scalloped edge over on each piece, press again and hand-sew opening at the base closed. (See Pic C.)
- 6 Pin pocket to your project and sew all around, being sure to reinforce the top of pocket corners for strength. (See pics D and E.)



Find more inspiration on Ashley's cheery and stylish blog www.lazydaisyjones.com You can also pick up a copy of her sewing pattern for women and girls S8087, created in association with Simplicity at www.simplicitynewlook.com for just £5.65



threaders™
BY CRAFTER'S COMPANION



Woodland Wonderland range available now!

Want more inspiration?



FREE PATTERN DOWNLOADS AVAILABLE FROM bit.ly/threaders-patterns

View the full collection at www.crafterscompanion.co.uk

The Sutton

OFF-THE-SHOULDER

dress

Download
FREE
TEMPLATES



Halfway between nautical and Parisian chic, sew up some Riviera style with an on-trend ruffle front dress while planning your escape to Saint-Tropez

Project **MELISSA MORA** Melly Sews
Photography **ALISON EDEN COPELAND**

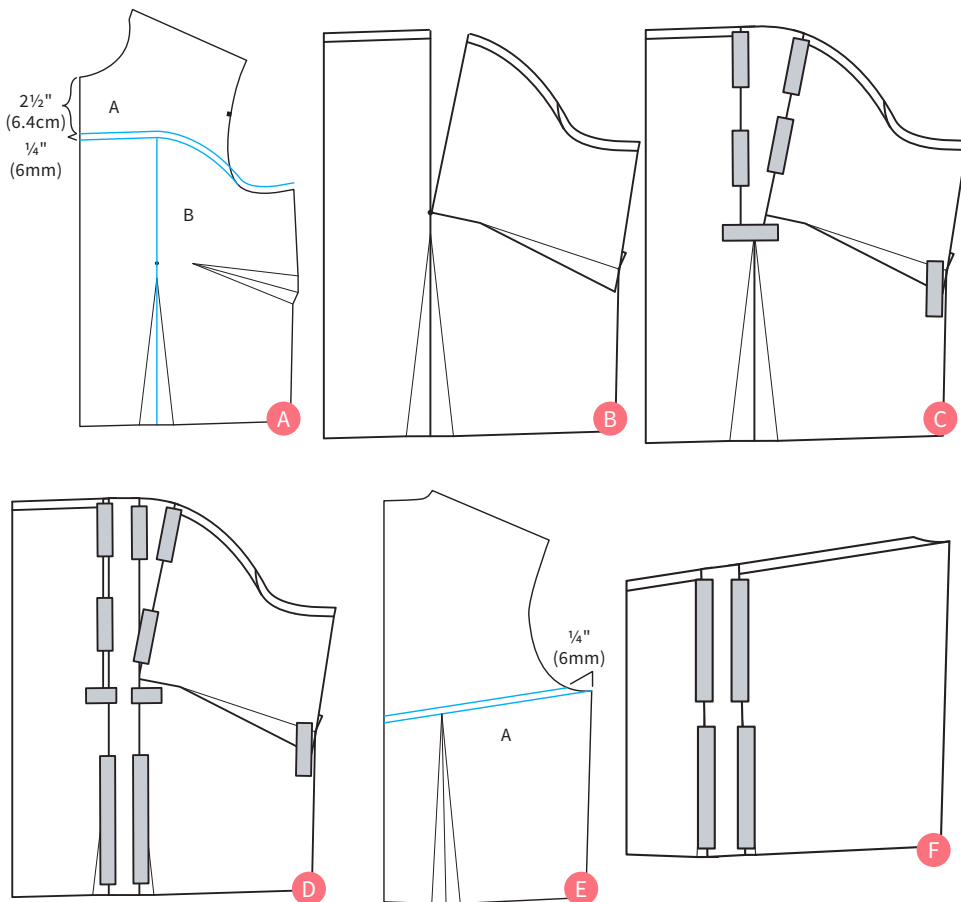

Skill level ♥♥

MATERIALS:

- ♥ light- to medium-weight woven fabric such as cotton or double gauze
- ♥ 3 yards 3/8"-wide elastic
- ♥ 1 pack of single-fold bias tape
- ♥ templates downloaded from www.lovesewingmag.co.uk

How to make

- 1 Modify the front bodice. (See Pic A.) Make a mark (A) 2½" down on the centre front neckline. Extend the centre line (B) of the waist dart up through the bust point and about 5" beyond. Draw a horizontal line from mark A to line B that curves down toward the armhole after reaching line B. Add a ¼" casing allowance along the new neckline.
- 2 Cut out the new bodice shape, then cut down line B to the bust point. Pivot this piece until the dart legs are on top of each other, to transfer the bust dart fullness to the neckline. (See Pic B.) Paper over the dart created on the neckline. (See Pic C.) Slash the entire pattern along the centre of the waist dart and spread pieces ½" apart. Paper over the gap. (See Pic D.)

- 3 Modify the back bodice. Draw a line (A) from the point of the armhole to the centre back, touching the top point of the back dart. Add a ¼" casing allowance along the new neckline. (See Pic E.) Slash the entire pattern along the centre of the waist dart and spread pieces ½" apart. Paper over the gap. (See Pic F.)

- 4 Cut front and back bodice pattern pieces on the fold out of main fabric.

- 5 For the skirt, cut two rectangles for a midi skirt length and 1.5 times the waist measurement in width. You may need to piece three pieces together for larger sizes to get the correct width.

- 6 For the ruffle, cut two rectangles of fabric that are 7½" tall and the same width as the elastic listed in the chart.

- 7 With the ruffle pieces RST sew both side seams. Finish the raw edges.

- 8 Hem the bottom edge of the ruffle by folding ¼" to the WS twice and sewing in place.

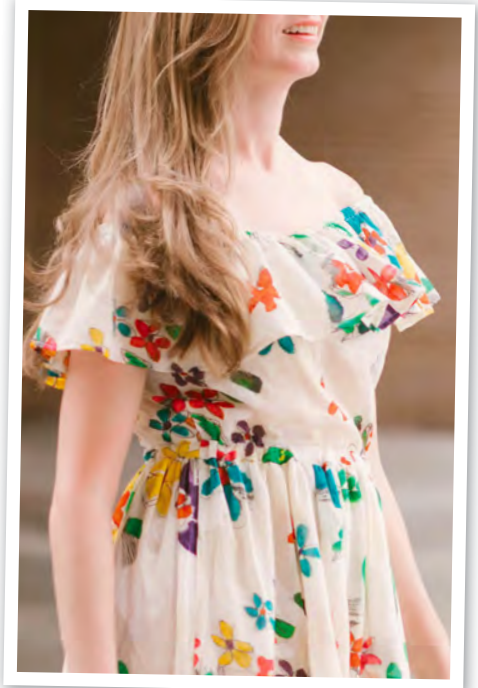

SIZING:

Size	Bust	Waist	Neck to Waist
0	31"	26"	14½"
2	32"	27"	15"
4	33"	28"	15¼"
6	34"	29"	15½"
8	35"	30"	15¾"
10	36"	31"	16"
12	37"	32"	16¼"
14	39"	34"	16½"
16	40"	36"	16¾"
18	42"	38"	17"
20	43"	40"	17¼"
22	45"	41"	17½"

FABRIC REQUIREMENTS: SHOULDER ELASTIC:

Size	45" wide	58/60" wide	Size	Measurement
0	3 yd	3 yd	0	37½"
2	3 yd	3 yd	2	38"
4	3 yd	3 yd	4	38½"
6	3 yd	3 yd	6	39"
8	4 yd	3 yd	8	39½"
10	4 yd	3 yd	10	40"
12	4 yd	3 yd	12	40½"
14	4 1/3 yd	3 yd	14	41"
16	4 1/3 yd	3 yd	16	42"
18	4 1/3 yd	3 yd	18	43"
20	4 1/3 yd	4 yd	20	44"
22	4 1/3 yd	4 yd	22	45"

THE SUTTON OFF-THE-SHOULDER DRESS

9 Fold the top edge of the ruffle $\frac{1}{4}$ " to the WS and press. Fold again, $\frac{1}{2}$ " to the WS to form a narrow casing. Stitch close to the folded edge, leaving an opening to insert elastic.

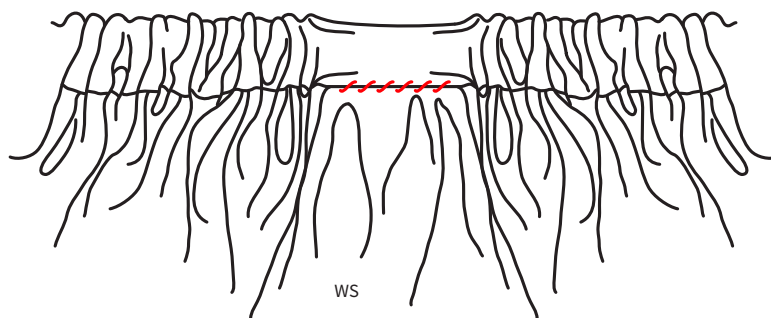

10 Cut a piece of $\frac{3}{8}$ "-wide elastic to the length on the elastic chart. Use a safety pin to insert it in the ruffle casing, being careful not to twist it.

11 Overlap the edges of the elastic $\frac{1}{2}$ " and stitch together. Sew the opening closed. (See Pic G.)

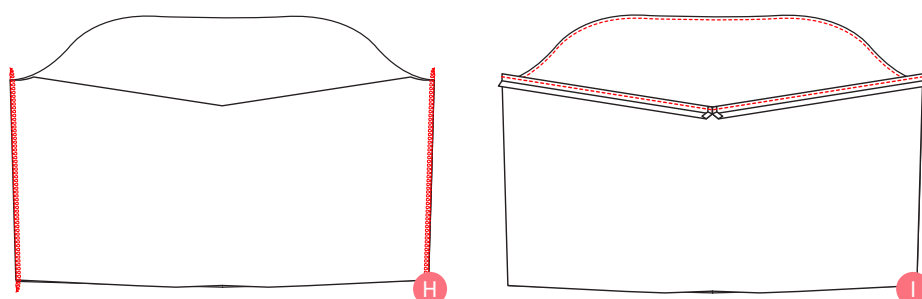

12 Place front and back bodice pieces RST. Sew the side seams and finish the raw edges. (See Pic H.)

13 Pin an unfolded piece of single-fold bias tape all around the neckline of the bodice, RST, starting at the centre back. Fold the short ends of the bias tape $\frac{1}{4}$ " to the WS at the beginning and end. Stitch along the crease line closest to the edge (See Pic I.) then turn bias tape to the WS of the bodice. Sew close to the folded edge to form a casing. (See Pic J.)

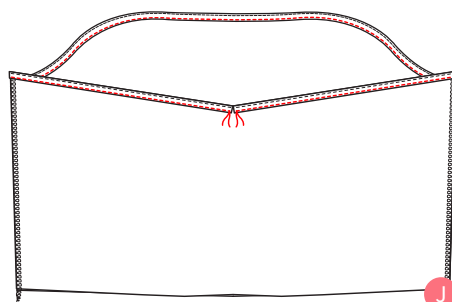

14 Cut a piece of $\frac{3}{8}$ "-wide elastic to the high bust measurement. Using a safety pin, insert elastic in casing starting at centre back, being careful not to twist. (See Pic K.)

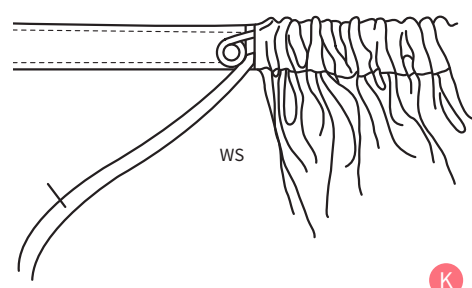

15 Overlap the edges of the elastic $\frac{1}{2}$ " and stitch together. Stitch down the short edges of the bias tape, anchoring the elastic at centre back.

16 Place the skirt pieces RST. Sew the side seams and finish the raw edges. Fold the skirt hem $\frac{1}{2}$ " to the WS twice and sew the hem.

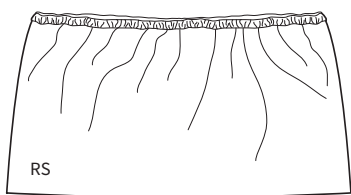

17 Gather the skirt to the same width as the bottom of the bodice. (See Pic L.)

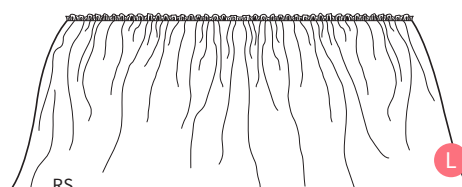

18 Turn the bodice WS out. Put the skirt RS out inside the bodice, matching the side seams. Pin in place and sew the waist seam.

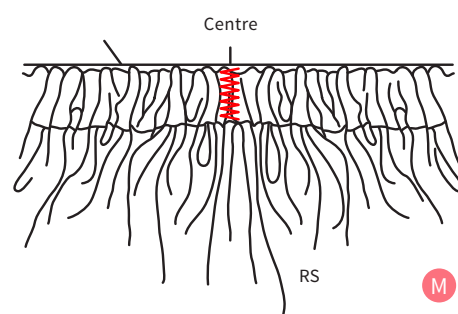

19 Turn through so the bodice is now inside the skirt. Begin to bind the waistline seam with bias binding by aligning the raw waistband seam with the bias edge. Sew in place, overlapping the ends.

20 Press the bias tape and waist seam allowance up toward the bodice to form a $\frac{1}{2}$ " casing. Stitch close to the edge, leaving an opening to insert the elastic. Your stitching will show on the RS, so use co-ordinating thread.

21 Cut a piece of $\frac{3}{8}$ " elastic to the waist measurement. Using a safety pin, insert elastic in casing. Overlap the edges of the elastic $\frac{1}{2}$ " and stitch together, then sew the opening closed.

ruffle to the right side of the bodice, matching the side seams. Stitch the ruffle to the bodice in a vertical line at the centre front and centre back, back stitching a few times to make sure it is secure. (See Pic M.) This will prevent sliding inside the casing and leaves the ruffle free to be worn on or off the shoulder.

22 Place the ruffle over the bodice, WS of the

Discover all the ideas, **inspiration** and **crafting** supplies you could ever dream of!



AUTUMN SHOWS 2016

Stitching, Sewing & Hobbycrafts

EventCity, Manchester - 8-10 September

Stitching, Sewing & Hobbycrafts

Westpoint, Exeter - 22-25 September

Crafts for Christmas/ Stitching, Sewing & Hobbycrafts

SECC, Glasgow - 27-30 October

Crafts for Christmas/ Stitching, Sewing & Hobbycrafts/ Art Materials Live

NEC, Birmingham - 3-6 November

Cake International

NEC, Birmingham - 4-6 November

Simply Christmas/ Stitching, Sewing & Hobbycrafts

ExCeL, London - 17-19 November

Country Homes & Interiors Christmas

Stonor Park, Henley-On-Thames - 25-27 November

2 SHOWS
FOR THE
PRICE
OF 1

4 SHOWS
FOR THE
PRICE
OF 1

2 SHOWS
FOR THE
PRICE
OF 1



Jewellery Making & Beading / Papercraft & Cardmaking / Festive Crafts / Demonstrations / Workshops
Cake Decorating & Baking Supplies / Art Supplies / Knitting, Stitching & Dressmaking / Christmas Gifts

Buy tickets online ichfevents.co.uk or Phone Ticket Hotline **01425 277 988**

ICHF Events
A Time Inc. UK Company

SAVE UP TO £2 OFF!
Each adult and senior ticket if ordered at least one week before the show.
Children under 16 go FREE when accompanied by a parent

THE THRIFTY STITCHER

There are lots of 'freestyle' systems around that will enable you to make simple clothes without having to buy a pattern or draft one up. In this issue Claire-Louise Hardie explains how to rub off your favourite garment!



Claire-Louise Hardie

You can make great clothes without a paper pattern! In the early 20th Century Madame Vionnet made stunning handkerchief dresses from squares of silk, and took inspiration in her designs from Japanese kimonos constructed only from rectangles.

If you can draw straight or curved lines and like a spot of maths, a freehand system may well be your path to making clothes you love. Here are my top five techniques.

Freehand cutting

Sewing Bee series 2 finalist Chinele Bally uses a very simplified drafting system directly onto fabric in her book *Freehand Fashion*. This style of cutting is popular in both African and Asian countries where a local dressmaker applies your body measurements straight onto fabric to create the garment pieces.



Geometric shapes

My colleague and friend Rosie Martin has released her second book *No Patterns Needed* that utilises simple geometric shapes to make



fashionable garments. I recently followed her system to create a flowing circle dress. The bulk of the dress is cut from a simple circular section, and I used a sleeveless vest to get the shape of the neck and shoulders.

Direct measurements

This works for really simple shapes like a pleated skirt or a garment without much shape and detail. You simply measure all key parts of the garment and transfer them over onto a piece of paper. For example, the length of a waistband, the depth of that waistband etc.

Over draping

This is useful for complicated designs like a waterfall frill or a ruched panel, where simply measuring or tracing would be impossible. Use a lightweight piece of muslin to lay over the area you wish to pattern, and pin into all the corresponding folds and tucks. Once you've done this, you can mark the perimeter and then all the internal pleats etc with a pencil. Take careful pictures of how it all looks, and unpin your muslin. This can then be used to transfer the shape onto a piece of paper as your pattern.

Tracing

This method is often called rubbing off! If you have clothes you love that fit really well this method ensures perfect patterns! Let's delve into this technique further.

I bought this black and white striped dress a few years ago and have literally worn it out. Since I love the shape and fit, I decided to rub off the pattern to make more. I was able to add a little extra width to my new versions! Although the dress has bust darts, I've chosen to leave them out in my new version for a looser fit.



Tips to note:

- ♥ You'll need a large sheet of paper, a large corkboard or piece of foam, pencils and a tracing wheel.
- ♥ Make a note of the grainline on any pieces not folded in half.
- ♥ Fold each anticipated pattern piece in half, matching seams together and pin to stop the halves from moving apart and giving you an inaccurate rub off!
- ♥ Your garment may not lie completely flat as you work so you may need to trace in sections, creating 'anchor' points and adjusting as you go.

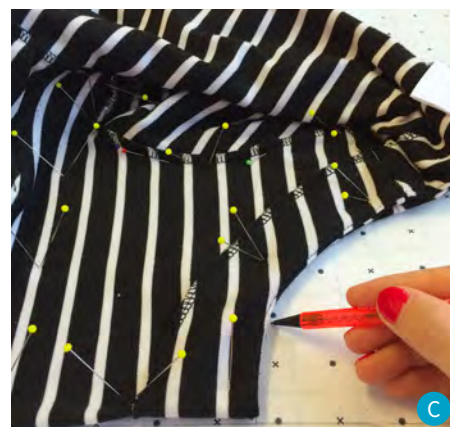
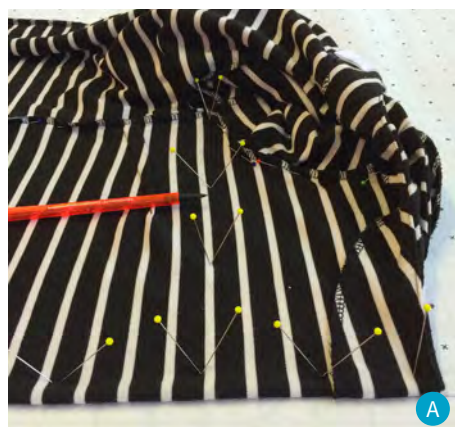

How to make:

- 1 Mark a 'baseline' on your paper; a vertical line with a horizontal line across it. Use this to line up centre front folds of your garment or grainlines. Lay the paper on top of the corkboard.
- 2 With the dress folded in half, and pinned at side seams and armholes, line up the centre front folded edge with the vertical base line, and the hem with the horizontal base line. Pin in place horizontally across the chest area to form an 'anchor'. (See Pic A.)
- 3 Pin the side seams to the board from the hem, up to the horizontal anchor line at chest level, making sure the dress is flat and relatively taut. Use the pointed tracing wheel to mark the side seam onto the paper. (See Pic B.)
- 4 Release the pins below the chest level 'anchor' line. Pin the upper shoulder, neck and armhole flat to the board, then trace the internal armhole and shoulder lines, and use a pencil to mark the outline of the neck. (See Pic C.)
- 5 Remove the dress from the board, and connect the dots with your pencil. Smooth the curves and lines with a French curve and ruler. At this stage I used a red pencil to add an additional 1cm at the side seams to make my new version a bit looser. (See Pic D.)
- 6 Repeat the same process for the back of the dress. Once traced, measure the side seams and adjust if they aren't the same.
- 7 Repeat the process for the sleeve folded in half along its length, and pinned together but place along your horizontal baseline. Trace as before starting with one half of the sleeve. Flip the folded sleeve over the baseline and trace the second side. Don't assume that the front

and back sleeve head shapes are the same! (See Pic E.)

- 8 Remove the sleeve and smooth all the traced lines. Because I added 1cm to the side of the dress, I also needed 1cm adding to the underarm seam of the sleeve. Before adding the seam allowance, measure the armholes and the sleeve head to make sure they'll fit together, and adjust if necessary.
- 9 A double tracing wheel can make adding seam allowance to curves really easy. Once the lines are marked, I go over with a blue pencil so I can easily identify the cutting lines! (See pics F and G.)

Make a wearable toile

I used a ponte Roma from my stash that had a little less stretch than the original, but not so much that it would affect the fit. Try on before finishing off hems and your neckline to fine tune your fit.

Just a note:

Label your pattern so you can reuse it!

Take care not to infringe someone else's design. I only ever make copies for myself of clothes that are vintage or are no longer available, and shapes that I'd like to alter from the original.

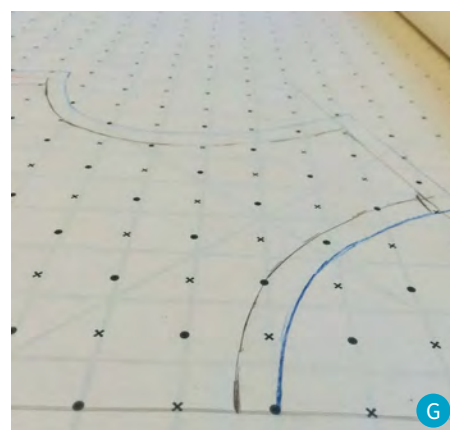
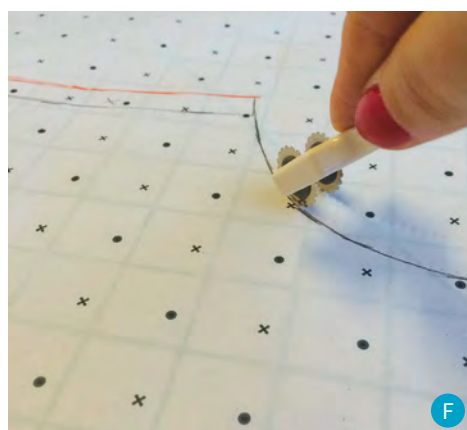
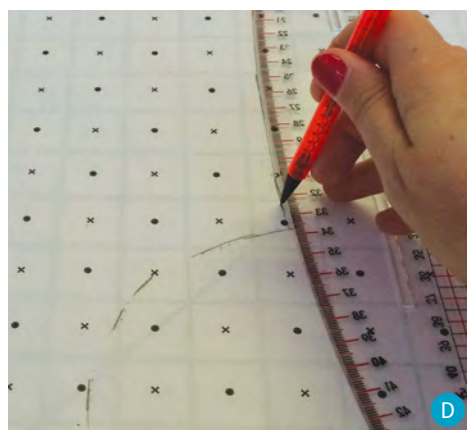

EST 1963

DIRECT SEWING MACHINES



SALES · SERVICE · TUITION

0117 9778216

www.direct-sewingmachines.co.uk

46 Sandy Park Road,
Brislington, Bristol, BS4 3PF

Bernina - Janome - Singer - Pfaff -
Frister Rossman - Horn



Blue Buttons

BlueButtonDesigns
djpproducts@msn.com
07540 634 351

Blue Buttons Designs
Traders Outlet
3-7 Tatton Road, Sale,
Cheshire, M33 7EB



Bobbins & Buttons

15% off fabrics enter **LOVE15** at checkout

RELEASE YOUR HANDMADE

Fabulous fabrics and friendly sewing classes in Leicestershire

www.bobbinsnbuttons.co.uk

harlequin-uk.com

Harlequin

MAKING GREAT THINGS **IN YOUR FABRIC**

SINCE 1968!

TIES
WAISTCOATS
BELTS
FABRIC BUTTONS
BRIDAL LOOPS

NEW CATALOGUE

CLUTCH BAGS from only £30 made in your fabric

Akemi Fabrics

An Exclusive Online Fabric Shop for Quilters, Dress Makers and Interior Designers. We offer you:

Save 30% on all Lewis & Irene fabrics until the end of August*

10% Introductory Discount on you First Order (Use Code: firstorder10)

www.akemifabrics.co.uk
hello@akemifabrics.co.uk

*While stocks last. Cannot be used in conjunction with any other offer. For more details of the fabrics on offer, go to the Sale section on the Akemi Fabrics website.

BECCLES SEWING & HANDICRAFTS

DRESSMAKING & CRAFT FABRICS,
HABERDASHERY & CRAFT REQUIREMENTS
SEWING MACHINES REPAIRS & SALES

Authorised dealer for:
JANOME, BROTHER, BABYLOCK, SILVER, ELNA, SINGER,
JUKI, ALFA & FRISTER+ROSSMANN.



15A, Blyburgate, Beccles, Suffolk NR34 9TB
01502 714234

Intrepid explorer

RUCKSACK

This casual and modern rucksack is perfect for everyday use. We chose quilted fabric, but any other strong fabric would also work as the outer layer

Project **SOPHIE PESTER & CATHERINA BRUNS** Supercraft
Photography **ANNE DEPPE**



Download
FREE
TEMPLATES

INTREPID EXPLORER RUCKSACK

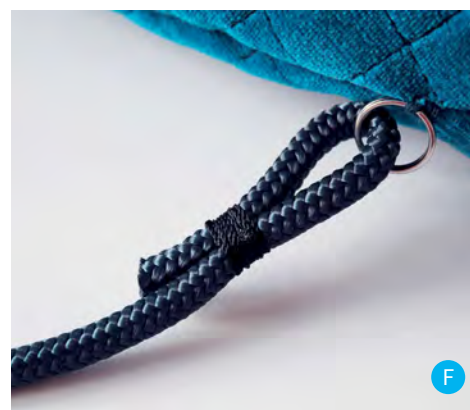
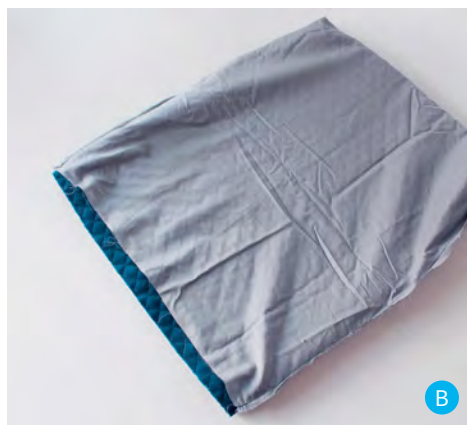

Skill level ♥♥

MATERIALS:

- ♥ 120x50cm quilted or medium weight material
- ♥ 120x50cm soft, supple lining material
- ♥ 8 8mm-diameter gold-coloured eyelets
- ♥ 2 1.5cm-diameter metal rings
- ♥ 200cm 6mm-wide co-ordinating cord for the straps
- ♥ 70cm 1.5cm-wide leather strapping
- ♥ air-erasable marker
- ♥ co-ordinating thread
- ♥ templates downloaded from www.lovesewingmag.co.uk

CUTTING:

- Cut 1 template on the fold in main fabric
- Cut 1 template on the fold in lining fabric

How to make:

- 1 Cut out both pieces of fabric following the templates, taking care to follow the actual dimensions indicated. Fold the outer material in half, RST, and pin along the sides. Repeat for the lining material.
- 2 Sew both sides on the outer material. On the lining piece, sew the sides but leave the gap as on the template for turning through later.
- 3 Square the corners by pressing the corners the opposite way, so the side

seam aligns with the bottom edge, and stitch across about 4cm in from the point. This makes a strong seam. (See Pic A and the tutorial below.)

- 4 Turn the outer material right side out and slip the lining material bag over it so that the right sides of both pieces are facing each other. Sew both bags together along the upper edge. When doing this, align the upper edges together, despite the 1cm difference. (See Pic B.)

- 5 Now turn the rucksack through the opening in the lining material. The lining material will now be on the inside. Strengthen the edge of the rucksack with a second topstitched seam. (See Pic C.)

- 6 Sew up the opening in the inner lining by hand. The basic body of your rucksack is now complete. (See Pic D.)

- 7 Mark the eight positions for the eyelets on the inner lining. Attach the eyelets to the fabric following the manufacturer's instructions. Take care to make the holes for the eyelets as small as possible, otherwise the material around the eyelets can easily fray. (See Pic E.)

- 8 On the outside of the rucksack, hand-sew a small metal ring into the seams on both

sides, as shown in the picture above.

The distance from the base to the ring should be 10cm. Thread the cord through the middle eyelets and then finally through the two metal rings on the sides.

- 9 Make a loop in the cord and wrap the ends firmly a few times with nylon thread to secure. Tie the ends of the thread tightly. Heat the ends carefully with the lighter to fix the knot. (See Pic F.)

- 10 Thread the leather strap through the two remaining eyelets to keep your rucksack closed.

TUTORIAL: SQUARING OFF CORNERS

Squaring off corners can be a little confusing. Align the side seam with what would be the bottom seam and then sew across the base of the triangle you have made. You can trim the triangle to avoid bulk

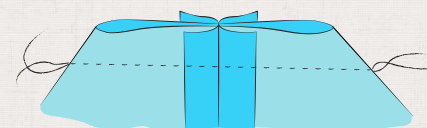



Boxy Ikat
TOTE

*Work the oversized trend with this gorgeous big holdall bag.
There's a roomy pocket inside and sturdy webbing handles*

Project **FIONA HESFORD** Sewgirl
Photography **ALEX WRIGHT** teneight

BOXY IKAT TOTE

Skill level ♥

MATERIALS:

- ♥ 1m 150cm-wide thick Ikat print cotton fabric
- ♥ 1.6m 5cm-wide webbing, cut into two pieces of 80cm each
- ♥ 2 small magnetic bag clasps
- ♥ 2 press fasteners (optional)

NOTES:

Finished bag measures approximately 84x61cm

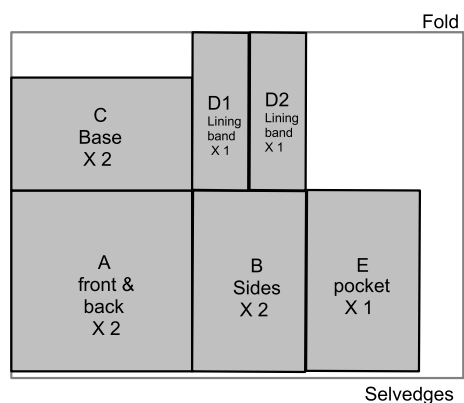

CUTTING:

Annotate your pieces with labels made from masking tape or water-soluble marker
 A = Centre front and back panel (use with stripes running vertically) cut two pieces 40cm square
 B = Side panels cut two pieces 40x25cm
 C = Base cut two pieces 40x25cm
 D1 & D2 = Inner lining bands cut two pieces 63x12.5cm
 E = Inside pocket cut one piece 40x25cm

How to make:

- 1 Sew a 1cm hem along one long side of your pocket (E) piece. Pin to the WS of one front piece at lower edge (with stripes running vertically). (See Pic A.)
- 2 Place the two base (C) pieces together WST. Pin then tack-stitch all around. Pin the front and back (A) pieces to the base at each of the long edges with RST. Sew a 1cm seam, finish raw edges, press, then top-stitch on RS on base side. You should now have one long strip front, back with the base piece at the centre. (See pics B and C.)
- 3 Now pin RST the side (B) pieces to the base piece at short sides. Sew a 1cm seam, finish raw edges, press then top-stitch on the RS. You should now have a cross formation. (See Pic D.)
- 4 To sew French seams at the sides, pin the front to the sides WST. Sew a 5mm seam. Turn bag through and press the seams so the



raw edges are encased. Pin, then sew again at 1cm. Repeat for the remaining sides.

5 With the lining band pieces (D1 & D2) pin RST at short sides to make a 'ring'. Press seam flat open and finish raw edges. Fold over then sew a 1cm hem at lower long raw edge all around.

6 Pin one handle piece at front top raw edge line up to the side seam edge, extend handle downwards. Repeat for back and second handle.

7 Pin lining 'ring' piece to bag matching raw edges at top RST and sandwiching the handles between. Sew a 1cm seam all around. Press seam on RS towards bag.

Top-stitch on bag side 4mm from seam. (See Pic E.)

8 Press lining ring over to inside of bag. Attach a magnetic clasp to the inside edges, centred between the handles. Add press fasteners to either side of side panels on the RS so the bag can be retracted and expanded.

WE USED
 Sommar print,
 £5 per metre,
www.ikea.co.uk



Introducing the Fold Away Petite - Dunster Edition
small but perfectly formed! With a small footprint
when closed and a folding work table there is a
spacious work area and plenty of storage.

fold
away **Petite**

Dunster Edition



- § Folding desk offering a generous work space
- § Choice of storage racks to keep supplies
- § Cable access to enable integrated power
- § Optional built in lighting pack

Regular Price £995
(excluding delivery and lighting kit)

Magazine Offer
£850 (SAVE £145)

Mainland UK delivery £35 extra
Optional lighting kit £50 extra
Offer Coupon - DUN715



Unit pictured
in Vanilla finish

*Specially designed with
the quilter in mind*

Choose options
to suit you

fold
away **Deluxe**

Watersmeet Edition

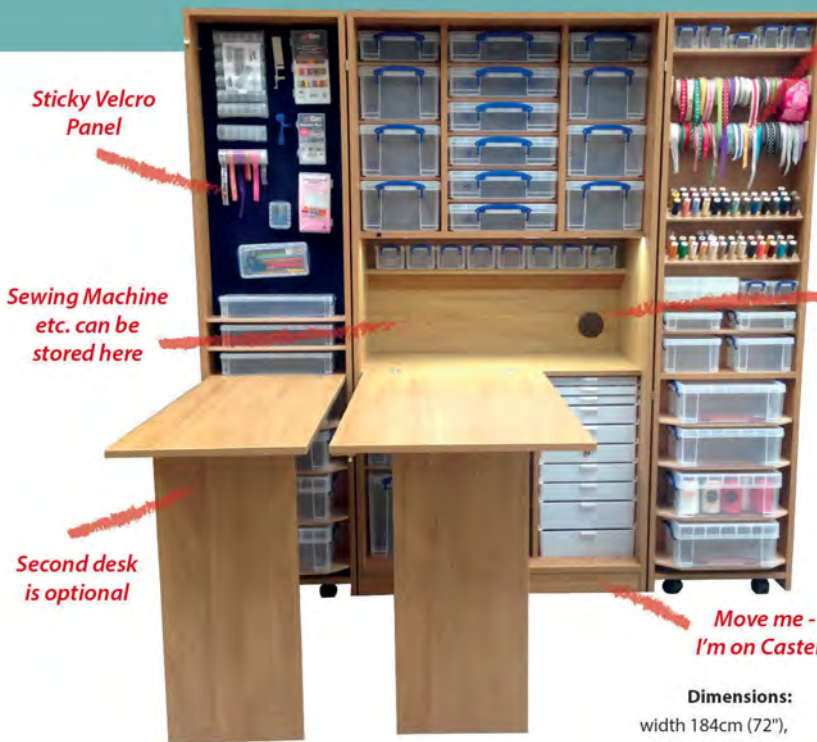

Sticky Velcro
Panel

Sewing Machine
etc. can be
stored here

Second desk
is optional

Move me -
I'm on Casters!

Dimensions:

width 184cm (72"),
depth 50cm (20")

with desk folded up, depth 150cm (59")
with desk(s) in use, height 183cm (72")

Unit pictured
in Oak finish

Finished Crafting...
Then just Fold Away to a unit
which is barely larger than a
standard double wardrobe

Add Power -
Cable Access
here

Fold Away Deluxe - Watersmeet

Regular Price £1495
(excluding delivery and lighting kit)

Magazine Offer
£1195 (SAVE £300)

Mainland UK delivery £50 extra
Optional lighting kit £50 extra
Offer Coupon - WM715



width 92cm (36"),
depth 65cm (25 1/2"),
height 183cm (72")

Ribbons

Threads

Lighting



Please note all furniture items are supplied self assembly -
assembly can be arranged please call for further details and charges

www.storage4crafts.co.uk

mail@storage4crafts.co.uk

Call us free
0800 048 8606

Offers expire end of month following magazine publication
(eg. Jan Issue expires end of Feb)

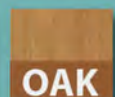
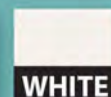
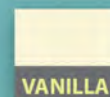

5 ways to add SCUBA TO YOUR WARDROBE

HOW TO TELL THESE FABRICS APART

♥ Scuba is a type of double knit made from polyester and spandex, with a very fine gauge thread, and smooth texture. This is what the clothes in magazines or the high street have been made of, and it's extremely likely that if you've bought 'neoprene' from a fabric shop you've actually bought scuba.

♥ Neoprene is a synthetic rubber and fabric hybrid that is more durable, more flexible and a better insulator, hence being primarily used for wetsuits. Essentially it's a thin knit fabric sealed onto spongy foamed neoprene.

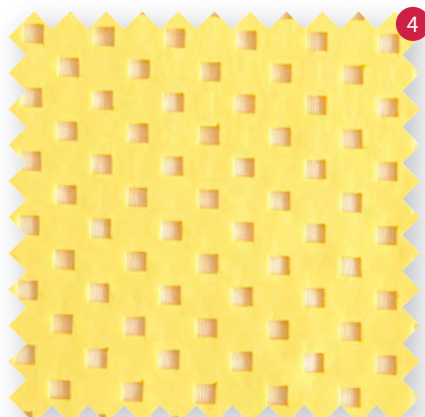

SAVE £1
on each metre of these gorgeous Fabworks neoprene designs. Use the code **LOVESEWING31** at the checkout to save on your order!



TOP FABRIC PICKS

Take a look at these fabulous scuba fabrics available to buy right now!

- 1 Photographic floral maze scuba, £6 per metre, www.fabworks.co.uk
- 2 Green double layer bodycon scuba, £4.99 per metre, www.minervacrafts.com
- 3 Deep turquoise scuba, £6 per metre, www.fabworks.co.uk
- 4 Yellow laser cut scuba, £12 per metre, www.fabricgodmother.co.uk
- 5 Bold geometric print red, gold & navy scuba, £10.99 per metre www.minervacrafts.com
- 6 Peppermint beach silhouette scuba, £7 per metre, www.fabworks.co.uk

WHAT TO SEW

Take inspiration from these fabulous bloggers as they share their favourite patterns for scuba

1 *Burda 6925*

Gema of blog www.sequinsandslippers.com was inspired by the off-the-shoulder trend to sew this white scuba top.

2 *Butterick 5926*

We've shared Manju's fabulous sewing skills before but you'll love her floral scuba blazer showcased on her site www.sewmanju.wordpress.com

3 *Burda 6858*

Erica of blog www.ericabunker.com created a knock-out version of this dress with daring sheer panels.

4 *Paprika Patterns Opal cardigan*

Nicole used some of Fabwork's fun floral scuba to sew a cool coat-igan and used her leftover fabric to make shorts. Find more of Emma's makes on www.instagram.com/lastnightssewing

5 *Deer and Doe Zephyr*

We love how Camille has made an eye-catching staple skirt using view C of this pattern, which she shared on her blog en.decoudvite.com



TOP TIPS for scuba success

♥ Weighty and opaque, scuba is well suited to structured garments, it won't need a lining, and is perfect during autumn and winter for keeping you warm!

♥ You can leave the edges of this fabric raw but does look nicer when finished; why not try a bias bound hem?

♥ If using an overlocker, bulky layers of scuba can cause a problem for the knife, so best to trim your seams by hand before overlocking with the knife disengaged.

♥ Keep your iron on a low setting and if possible use a pressing cloth to avoid marking or melting your fabric.

♥ Keep your finished garment looking it's best by washing at 30 or 40 degrees and avoid tumble drying. Higher temperatures will damage the Lycra / spandex content in the fabric.

♥ To avoid skipped stitches or bunching beneath your presser foot it would be beneficial to use a walking foot for your machine sewing. This will feed the fabric evenly as you sew for perfect results.





Catch of the day
BUNTING

This cheerful string of sardines can be easily made from fabric scraps and would make a fun decoration in your kitchen, bathroom or a nursery

Project **DEBBIE VON GRABLER-CROZIER** Folk Art Factory
Photography **TYM LECKEY**

Download
FREE
TEMPLATES

WE USED

- Tilda Leaf Garland blue
£4.85 per FQ,
www.puddlecrafts.co.uk
- Tilda Gingham SL blue,
£4.95 per FQ,
www.stitchcraftcreate.co.uk
- Tilda Starflower blue
£3.75 per FQ,
www.puddlecrafts.co.uk

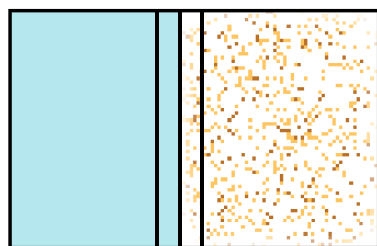

A

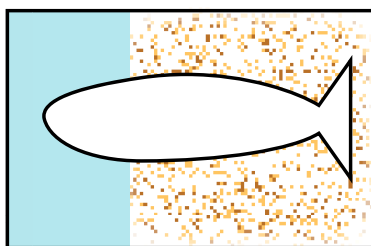

B

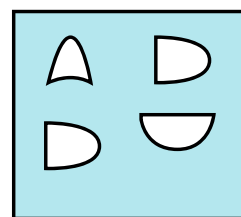

C

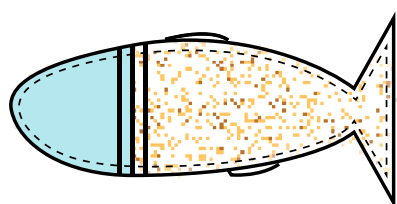

D

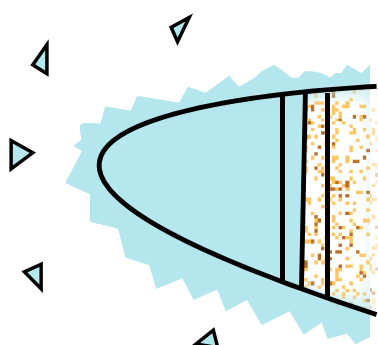

E

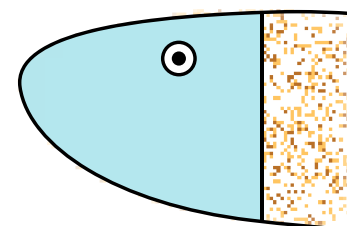

F

NOTE:

Use a 0.5cm seam allowance throughout

Skill level ♥

MATERIALS:

- ♥ 3 25cm strips linen fabric
- ♥ 25cm strip Tilda Leaf Garland
- Blue fabric
- ♥ 25cm strip Tilda Gingham SL blue fabric
- ♥ 25cm strip Tilda Starflower blue fabric
- ♥ toy stuffing
- ♥ natural hemp twine
- ♥ large-eyed needle
- ♥ 6 blue buttons
- ♥ water-soluble marker
- ♥ templates downloaded from www.lovesewingmag.co.uk

How to make:

1 Sew a piece of linen to a piece of patterned cotton fabric. Press the seam open. (See Pic A.)

2 Fold the assembled piece in half RST, matching the seam. Place the fish template on top, aligning the fish head on the linen. (See Pic B.) Transfer the pattern marks on with the water-soluble marker. Cut out the fish.

3 Cut the fins from the remaining linen. (See Pic C.) Place one pair RST. Sew around the outer edge and clip the seam allowances. Turn the right way out and top-stitch about 0.5cm from the edge. Repeat for all of the fins (there are four per fish).



4 Place the dorsal on one body piece with fin facing inwards. Repeat for the bottom fin. Put the other two fins aside.

5 With RST, sew around the fish leaving a small area on the bottom for turning out and stuffing. (See Pic D.) Clip and notch curved edges and turn out. Stuff well, pushing filling well into the face and slip-stitch the opening closed. (See Pic E.)

6 Hand-sew two blue buttons for eyes using a darning needle. Attach the first button then pass the needle through the

head and pull the thread taut to give the face a little shape. (See Pic F.)

7 Fold under the raw edge of the side fins and sew in position as indicated on the pattern. Repeat for the other two fish.

8 To finish, attach hemp twine to the mouths of the fish to hang them from. Thread the darning needle and pass through the tip of the fish's head, tie a double knot then snip the excess string away. This can be any length at all – use whatever you consider to look balanced.

Subscribe and SAVE up to 46% this summer

7 issues for just
£24.97 SAVE
£16.96



Simply Cards & Papercraft
The No.1 cardmaking
magazine

7 issues for just
£24.97 SAVE
£16.96



Papercraft Essentials
Britain's best-selling
papercraft magazine

7 issues for just
£22.67 SAVE
£19.26



Crochet Now
The UK's No.1 magazine
for crochet patterns

7 issues for just
£24.97 SAVE
£16.96



Knit Now
The UK's No.1 for
knitting patterns

7 issues for just
£24.97 SAVE
£16.96



Love Sewing
The UK's No.1
sewing magazine

7 issues for just
£20.97 SAVE
£13.96



Quilt Now
Britain's No.1 guide to
fabric and patchwork

5 issues for just
£23.97 SAVE
£15.98



Creative Stamping
The UK's No.1
stamping magazine

6 issues for just
£41.97 SAVE
£17.97



Die-cutting Essentials
Britain's No.1 die-cutting and
embossing magazine

Subscribing is quick and easy...

www.moremags.com/cpr7

Call 01858 438899 (quote code: SMMCCPR7)

Subscribe to the UK's best craft titles at the hottest prices. This summer, try something new or rekindle your love for a favourite craft and save £££s on the cover price. We have eight different titles to offer you, with a variety of exciting projects, the latest trends and inspiration inside every magazine. So sit back and enjoy the sun, but don't forget to subscribe as these offers can't last forever!

SAVE
up to **46%**
on the UK's
favourite craft
magazines!

Makes a great
gift idea!

Subscriber benefits

- ✿ Free delivery direct to your door
- ✿ Save money on every issue
- ✿ Crafting inspiration month after month
- ✿ Be the first to read the latest issue
- ✿ Free gifts with every issue worth up to £25!
- ✿ Never miss an issue
- ✿ Free access to The VIP Lounge - exclusive craft offers, projects, downloads and more



- Simply Cards & Papercraft** 7 issues for **£24.97**
The No.1 cardmaking magazine SAVE £16.96
- Papercraft Essentials** 7 issues for **£24.97**
Britain's best-selling papercraft magazine SAVE £16.96
- Crochet Now** 7 issues for **£22.67**
The UK's No.1 magazine for crochet patterns SAVE £19.26
- Knit Now** 7 issues for **£24.97**
The UK's No.1 for knitting patterns SAVE £16.96
- Love Sewing** 7 issues for **£24.97**
The UK's No.1 sewing magazine SAVE £16.96
- Quilt Now.....** 7 issues for **£20.97**
Britain's No.1 guide to fabric and patchwork SAVE £13.96
- Creative Stamping.....** 5 issues for **£23.97**
The UK's No.1 stamping magazine SAVE £15.98
- Die-cutting Essentials.....** 6 issues for **£41.97**
Britain's No.1 die-cutting and embossing magazine SAVE £17.97

Send to: (If buying as a gift, please include the payer's address on a separate sheet)

MR/MRS/MISS FIRST NAME
SURNAME.....
ADDRESS.....
..... POSTCODE.....
TELEPHONE.....
EMAIL.....

PLEASE CHOOSE YOUR METHOD OF PAYMENT:

1. CHEQUE/POSTAL ORDER

I enclose a cheque/postal order payable to 'Practical Publishing' for £.....

2. CREDIT/DEBIT CARD

Please debit my Visa/Mastercard/Maestro

Card No.

<input type="text"/>	<input type="text"/>	<input type="text"/>	<input type="text"/>	<input type="text"/>	<input type="text"/>	<input type="text"/>	<input type="text"/>	<input type="text"/>	<input type="text"/>
<input type="text"/>	<input type="text"/>	<input type="text"/>	<input type="text"/>	<input type="text"/>	<input type="text"/>	<input type="text"/>	<input type="text"/>	<input type="text"/>	<input type="text"/>

Valid from/Issue No.

<input type="text"/>	<input type="text"/>	<input type="text"/>	<input type="text"/>
----------------------	----------------------	----------------------	----------------------

Expiry date

<input type="text"/>	<input type="text"/>	<input type="text"/>	<input type="text"/>
----------------------	----------------------	----------------------	----------------------

CARDHOLDER'S SIGNATURE.....

SEND TO: (no stamp required in the UK) Practical Publishing Int Ltd, Tower House, Sovereign Park, Market Harborough, Leicestershire LE16 9EF

UK offer only. Your subscription will commence with the next available issue.

Value of free gifts per issue varies by title up to the value of £25

I DO NOT want Practical Publishing Int Ltd to contact me by email telephone post

Tick this box if you do not wish to receive promotional material from carefully selected third party companies

Quote code:
SMMCCPR7

Offer expires 30/09/2016

SEWING ROOM SWOON





Sewing room SWOON

*We love sharing beautiful sewing spaces with you; whether they are whole rooms stacked with supplies or carefully organised little nooks, it's creativity that counts. In this issue, crafty redhead Jen Walker of blog *The Gingerthread Girl* shows us her swoon-worthy spot that she shares with a fluffy sewing companion*

Sewing is my therapy – it really does keep me sane – I'm sure many others can relate. So, when I moved into my new house just before Christmas, I knew I needed to nab myself a room which could be completely dedicated to my sewing and craftiness. Heaven!

I spent a lot of time researching sewing room ideas online, mainly on Pinterest, to get an idea of the kind of style I wanted to go for. I knew I wanted a modern look, keeping the walls white and splashing blocks of colour around with the furnishing, features and cute little details. Seeing the scrabble tiles, cheeky fox and vintage suitcase always makes me smile.

The result – a sewing room that I absolutely adore working in, which is as practical as it is pretty! It's my happy place where I can relax and break away from the world with my sewing.

One of my favourite elements in the room is the huge drop-leaf cutting table that I keep separate to the trestle desk where my Janome machine and overlocker live permanently. It gives me so much space to spread out. I also love my pegboard, as well as my lovely roof windows that allow the daylight to come pouring in!

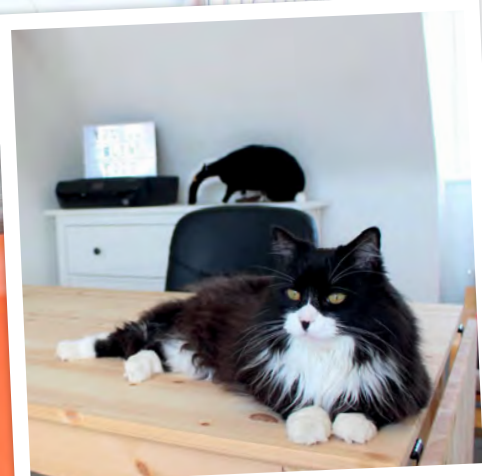
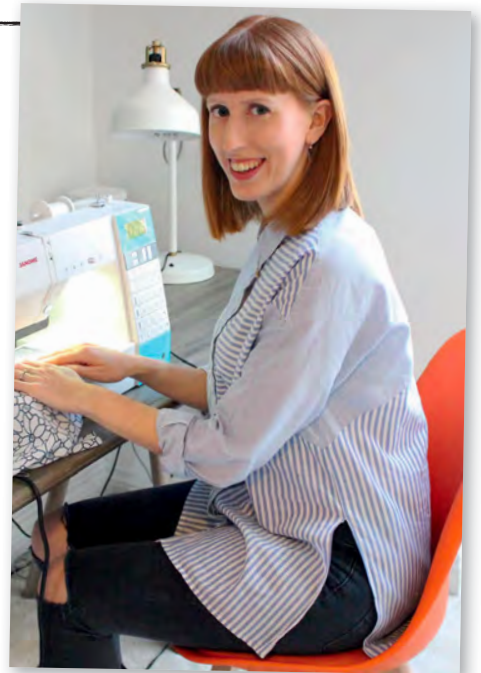

We recommend you check out Jen's blog www.gingerthreadgirl.co.uk where she showcases her creative makes and musings in her journey from newbie dressmaker to fully fledged sewing addict. Say hello on Facebook, Instagram and Twitter [@gingerthreadgrl](https://twitter.com/gingerthreadgrl)

Simple
sew

Discover the brand-new range of
patterns for dressmakers of all levels

SAVE
50%
ON OUR TWO NEW
TUNIC PATTERNS*
use code
TUNIC16

The Zoe Dress & Top
#SR15 Sizes 8-20
BEGINNER

The Nicole Dress
#SR19 Sizes 6-20
BEGINNER

Visit our website for...

- > Full video tutorials for all key dressmaking techniques
- > Step-by-step sew-alongs
- > Fabric inspiration & so much more!

Now available from
www.simplesewpatterns.com
& selected retailers

 simplesewpatterns  simplesewpatterns  @ssewpatterns  simplesewpattern

*Offer applies to paper patterns only from www.simplesewpatterns.com and is not usable in conjunction with any other promotion. Offer expires 12/10/16



Ticking stripe

DOORSTOP

*Cotton ticking isn't just for deckchairs!
Bring those stripes indoors
with this boxy doorstop*

Project **VICTORIA PEAT** Little Black Duck
Photography **TYM LECKEY**



NOTES:

On the main body pieces snip 5mm towards, but not right up to, each of the pattern dots to ensure your corners are ship shape in the finished doorstop

Home décor weight fabric works best, however you could also make this doorstop from a couple of tea towels to match your kitchen décor. We used bay stripe cotton by Fryetts, from www.dunhelm.co.uk

Use a 1cm seam allowance unless specified

Skill level ♥♥

MATERIALS:

- ♥ 35x140cm medium to heavyweight home décor fabric
- ♥ 25x70cm of lightweight calico for lining bag
- ♥ heavyweight iron-on interfacing for handle
- ♥ 5" zip
- ♥ medium weight iron-on interfacing for non-home décor weight fabric (optional)
- ♥ co-ordinating thread
- ♥ 1.5kg of rice, small pebbles or kiln-dried sand (like you can buy for children's sand pits)
- ♥ templates downloaded from www.lovesewingmag.co.uk

CUTTING:

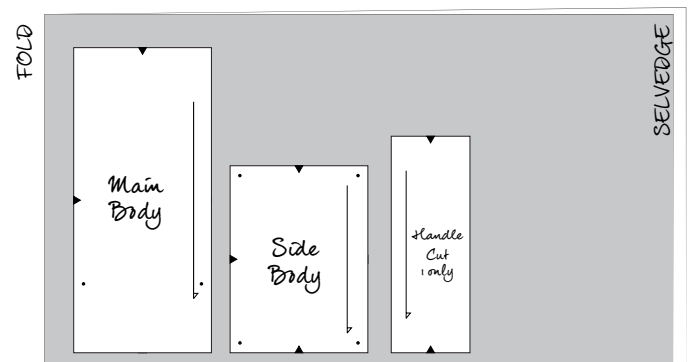

Loop – cut 1 fabric, cut 1 interfacing

Main body – cut 2

Side body – cut 2

Liner bag – cut 25x70cm rectangle

How to make:

- 1 Fold the handle in half creating a rectangle that measures 22x4cm wide, sew into a long tube.
- 2 Turn the tube through to the RS with the seam sitting in the centre (3cm from each outer edge). (See Pic.A.) Press flat and topstitch a few mm from each outer edge. Fold the handle in half and baste the raw edges together.

TICKING STRIPE DOORSTOP

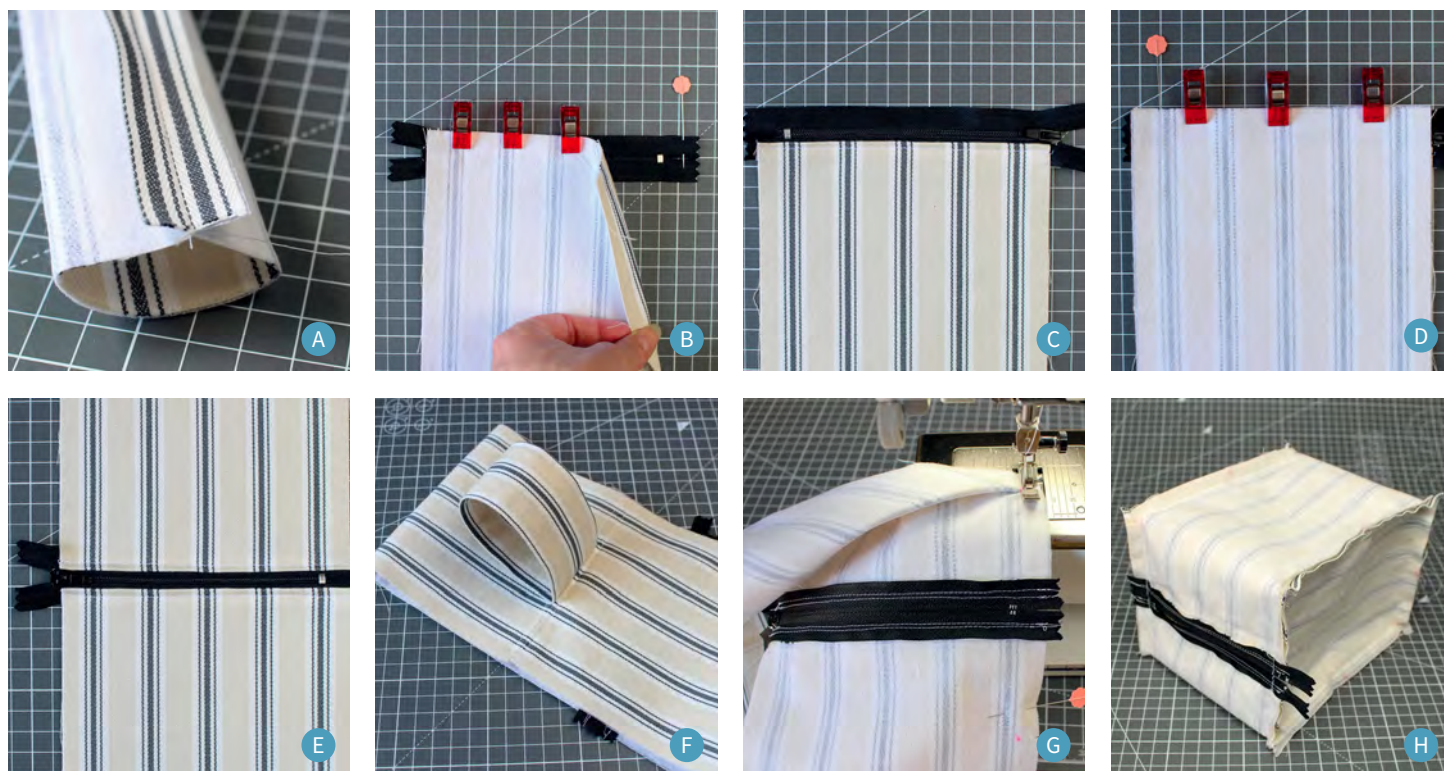

3 Place the zip RS uppermost. Place a pin to mark the outside edge of the zip stopper. Place one main body WS uppermost with the outside edge extending 1cm past the pin. (See Pic B.)

4 Sew along the zipper tape, approximately 6mm from the outside edge. Turn main body to RS and press (avoiding zipper teeth). Top-stitch in place approximately 4mm from folded edge, through all three layers. (See Pic C)

5 Repeat above steps with second main body piece and the other half of the zip. (See pics D and E). DO NOT trim the zipper tape.

6 With RST sew the two raw edges of the main body pieces together, sandwiching the ends of the handle in the middle, matching up the notches.

7 Turn through to the RS to check that the handle is positioned properly, before sewing a second line of stitching to secure the handle.

8 Remove the basting stitches from the short ends of the handle and press the seam allowances of the handle and the top of the doorstop open.

9 From the RS top-stitch a few mm from the seam. You may like to open the zip in order to make it easier to sew. (See Pic F)

10 With the main part of the doorstop (that

you have just made) WS uppermost, slip one side body piece inside the loop so that the two pieces are RST. Match up the raw edges and the notches on one side.

11 Starting from the notch, sew until you reach the dot. Stop with the needle in the down position.

12 Lift the presser foot and pivot the side body piece that is underneath 90° towards you until you line up the notch on the side body with the middle of the zipper teeth. (See Pic G)

13 Sew until you reach the next dot. Leave the needle in down position and pivot again so that you match the remaining notches.

14 Repeat the process for the remaining two corners of the first side of the doorstop and end back where you started. Turn through and check that the side has been inserted evenly.

15 Turn back through to the WS and insert the second side, opening up the zipper a little before you start.

16 Repeat the above process with the second side section. Turn through and check that the second side has been inserted correctly.

17 If everything is even turn back through to the WS and sew an extra row of stitching over each end of the zipper tape. (See Pic H)

18 Fold the liner bag piece to make a rectangle that measures 25x35cm. Sew around the three raw edges, leaving a 5cm gap on one edge for turning though and filling.

19 Turn through to RS and push out corners. Fill with 1.5kg of rice. Sew the opening closed by hand and push the rice bag into doorstop and zip closed.



Download
FREE
TEMPLATES



Magical

MERMAID

This cheeky little mermaid has her own unique style, with her flowing felt hair and multicoloured scales

Project & photography **HEIDI KENNEY** My Paper Crane

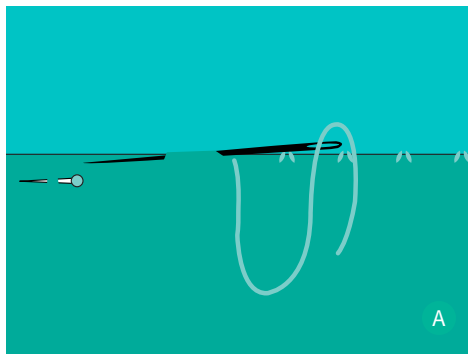

NOTE:

Finished size is approximately 5x15"

Seam allowance is 1/4"

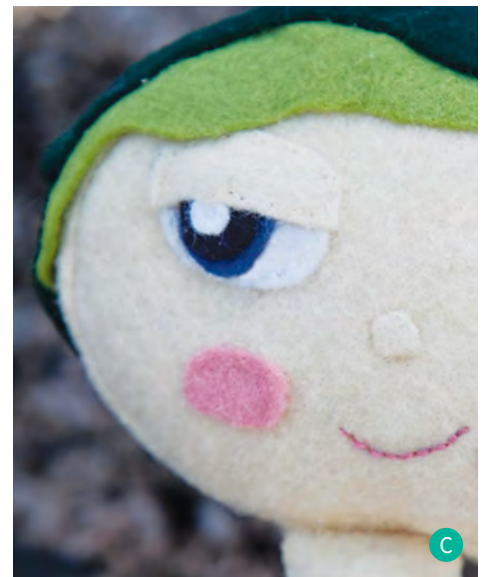

Skill level ♥

MATERIALS:

- ♥ 18x36" cream felt
- ♥ 9x36" various shades of green felt
- ♥ 6x8" gold felt
- ♥ 1x1 1/2" black felt
- ♥ 1 1/2x2 1/2" white felt
- ♥ 1x2" pink felt
- ♥ 1x2" coral felt
- ♥ pink embroidery floss
- ♥ toy stuffing
- ♥ fabric glue
- ♥ template downloaded from www.lovesewingmag.co.uk

How to make:

- 1 Trace the patterns and cut out templates for all the pieces.
- 2 Cut out the body, head pieces, nose and eyelids from cream felt. Use white for the eyes and eye highlights, black for the pupils, pink for the cheeks and coral for the shell bra. Cut the scales, hair and tail from the gold and greens.
- 3 Pin the long head strip around the edges of an oval head piece. Stitch to the other head piece, leaving a small opening for turning. Turn RS out. Stuff. Hand-stitch the opening closed. Set aside.
- 4 Sew together the two body pieces using a 1/4" seam allowance, leaving the neck open. Clip the seam allowance at the curves. Turn and fill with toy stuffing.
- 5 Turn under the edge of the neck opening and pin the open neck to the bottom of the head. Hand-stitch firmly together. (See Pic A.)

6 Glue the tail pieces to the bottom of the body.

7 Glue the scales to the body. Begin at the waist and overlap the scales as you go, staggering the colours. Allow to dry. (See Pic B.)

8 Use embroidery floss to back-stitch a small mouth. You can draw this lightly in pencil first as a guide. You can hide your end stitches behind the eyes and the cheeks. (See Pic C.)

9 Glue on the eyes, cheeks, nose and shell bra. Allow to dry.

10 Arrange the hair pieces as desired and glue them in place. Cut a couple more pieces if needed to cover any bare areas.



Find this project in *Seaside Home* compiled by Susanne Woods, £18.99, Stash Books



AMAZING
PRICES!!!

LIBERTY

ART FABRICS

Over 50% off RRP

Liberty Fabric £9.95 per metre*



Tana Lawns • Silks • Jerseys • Cords
Twills • Lifestyle Craft Cottons

*Applies to specific clearance lines only

Available at all stores and
online www.abakhan.co.uk

We have purchased these fabrics as a clearance lot
and designs, prints and colour ways will vary at each
store and online. Please check before traveling.



CROFT MILL



**Suppliers of mail order fabrics for over 40 years.
We source beautiful fabrics from Britain, Europe
and the rest of the world.**

It is easy to buy and it is delivered to your door.
Buy online at www.croftmill.co.uk or via our
Mail Order Catalogue

Request your free fabric catalogue today!

Telephone **01282 859281** | @CroftMillFabric | facebook/Croft-Mill-Fabric

Love Sewing

WITH

MINERVACRAFTS

WWW.MINERVACRAFTS.COM

Discover our beautiful selection
of Dressmaking Fabrics, with
thousands to choose from in
our huge range...

Visit www.minervacrafts.com and

GET 10% OFF

ALL OF OUR DRESS FABRICS

Simply enter the coupon code

LOVESEWING10

on the checkout page

One use per customer. Cannot be used in
conjunction with any other offer.

Love Sewing meets FELT MISTRESS

*This month we caught up with Louise Evans AKA Felt Mistress, whose weird and wonderful felt creatures have gained international fame. Her new book *Make Creatures with Felt Mistress*, published by Laurence King, is on sale now*



Hello! Tell us a bit about your journey – how did you become Felt Mistress?

The first character I made was a rabbit when I was about seven or eight. But the name Felt Mistress was just a joke name we thought up when I wanted to send my friend Craig a gift I had made for him. We didn't put anything else in the box with the felt character – just a business card signed 'Felt Mistress' and a lipstick kiss. It was a character called Krabula that Craig had designed and written comics about.

I had always made characters for friends as birthday gifts but never thought it could become a full-time career. After tweeting about some of my work, I was spotted by a fashion boutique that wanted me to fill its windows with my creatures for London Fashion Week. This then led to me doing Christmas windows for Selfridges and from that point on my creature creating was overtaking the wedding dress making side of my work.

The fine attention to detail in your work really brings your creations to life. Tell us a bit about the process of assemblage and turning the character in your head into a 3D reality

I trained in fashion design and millinery and, previous to working on characters, I worked for many years as a bespoke dressmaker, mainly making wedding dresses and formal wear for individual clients. I still use similar techniques when working out how to make a flat fabric into a 3D shape and clothing is a big part of my characters too. I will make up a paper pattern and toile the shape in fabric first to check I'm happy with everything, then move onto the chosen fabric. During my time at university I wanted to make hats and my university didn't have a millinery teacher so I arranged private

lessons with Mrs Payne, an elderly lady who had spent her life making hats. I would spend hours stitching something but if the stitches weren't perfect she wouldn't hesitate to make me undo them and start again. I have her to thank for my patience when hand sewing (and also my hatred of using glue on fabric). I love hand sewing and really enjoy adding the small stitched details, which I actually find relaxing!

What should we expect from your new book *Make Creatures with Felt Mistress*?

This is the first time that full Felt Mistress patterns and methods have been available. I hope the book teaches people new skills and encourages them to work with fabric that they may not have worked with before. Once people have made some of the characters in the book I hope they go on to design and make their own.

Finally, what can we expect to see from you next?

I have an exhibition and book launch at Colours May Vary in Leeds (until 21st September) where I will be exhibiting the characters from the book along with some other Felt Mistress characters, including a few new ones. Then I am off to Helsinki to do a residency there where I will be producing work inspired by the city. I've never been to Helsinki so I am very excited!



GET 35% off your copy of *Make Creatures with Felt Mistress* by entering the code **FELT35** when you check out at www.laurenceking.com



Washing line

PLAY TENT

There's nothing quite like the adventure of playing in a tent and this stripy linen version is super easy to make for hours of guaranteed fun!

Project **AMANDA RUSSELL & JULIET BAWDEN** R&B Designs
Photography **TYM LECKEY**

WASHING LINE PLAY TENT

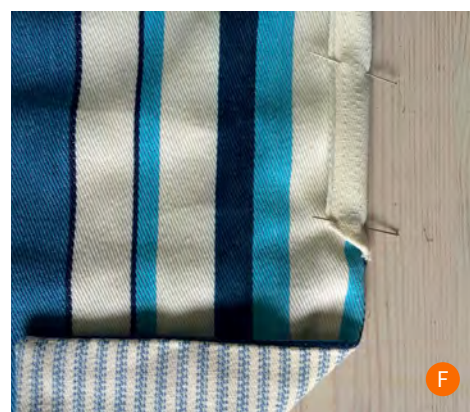
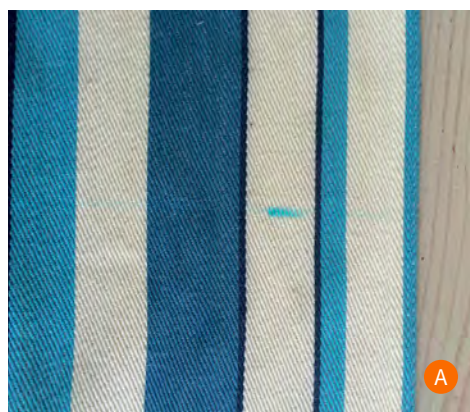

Skill level ♥

MATERIALS:

- ♥ 2.5m 135cm-wide outer fabric
- ♥ 1m contrast fabric
- ♥ 3.75cm-wide webbing
- ♥ 2.25cm-wide tape
- ♥ Korbond air-erasable marker

How to make:

- 1 For the tent, cut a length of outer fabric 180cm long, with RST fold the main fabric in half width ways. Mark the fold line with air-erasable marker pen at each end and periodic points along the length. (See Pic A.)
- 2 Cut a length of webbing 2cm shorter than the length of the folded edge.
- 3 With the fabric open flat, place the webbing along the central line you marked. Start 1cm in from the tent edges and then fold 1cm of the side fabric over the end of the webbing and pin. (See Pic B.)
- 4 Sew along both long edges of the webbing with the sewing machine. To find the position of the tie tapes, fold the tent on the central line and repeat to quarter the fabric, mark these three folds and also 2cm from both edges.

5 Cut five pieces of tape 1m long and attach to your marks at right angles to the webbing. (See Pic C.)

6 To make the side pockets cut two lengths of contrasting fabric 18x180cm. Take one and sew a 2cm hem on one long edge. Repeat with the other pocket.

7 Take a pocket and place with the RS on the WS of the tent, aligning the raw bottom edges. Pin then sew along three sides, leaving the top open.

8 Clip the corners of the pocket to reduce bulk. (See Pic D.) At the top of the pocket clip the seam allowance by 1cm (See Pic E.) and turn the pocket through to the RS. Turn the tent edge under by 1cm and top-stitch in place. (See Pic F.)

9 Segment the long pocket into individual pockets by dividing the length measurement by five, mark the fabric with vertical lines and sew the two layers together.

10 To make the sand bags cut 12 20cm squares of fabric. Sew around three sides with a 1cm seam allowance. Clip the corners and turn right sides out. Fill with rice or sand, turn the raw edge in and sew closed with the machine.





Plucky pelican
APPLIQUÉ

Brighten up a boring T-shirt with a fun nautical appliqué. We love the mix of hungry pelican and bright red and white stripes

Project **VICTORIA PEAT** Little Black Duck

PLUCKY PELICAN APPLIQUÉ

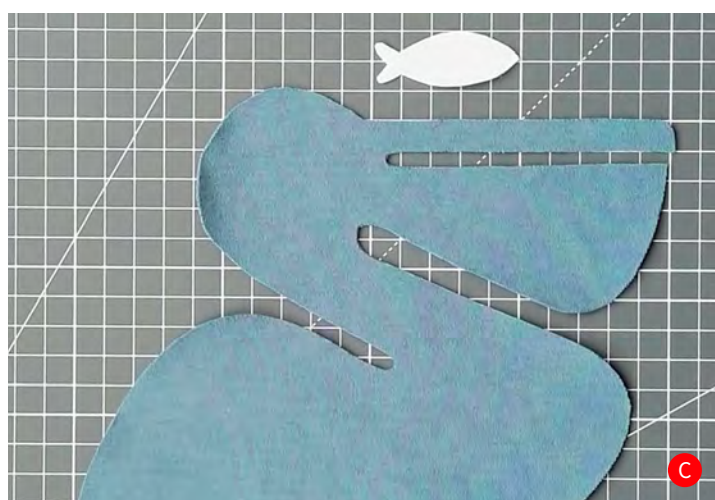

NOTE:

The finished pelican measures approximately 19.5cm (H) x 20cm (W)

Skill level ♥

MATERIALS:

- ♥ plain or striped T-shirt
- ♥ 25cm square double-sided interfacing eg Bondaweb or Steam-a-Seam
- ♥ 25cm square cotton or jersey for pelican
- ♥ 8x4cm of cotton or jersey for fish
- ♥ ¼-½" button for the eye (optional)
- ♥ 25cm square stabiliser, eg Stitch 'n' Tear
- ♥ co-ordinating thread
- ♥ downloaded from www.love sewingmag.co.uk

How to make:

- 1 Trace the pattern pieces onto the paper side of the double-sided interfacing (the shapes have already been reversed for you) and roughly cut out, about ¼" from the pattern line. (See Pic A.)
- 2 Iron shapes onto the WS of your appliqué fabrics. (See Pic B.)

3 Cut out along the pattern line with a pair of small sharp scissors, taking care around the pelican's foot and fish tail. (See Pic C.)

4 Arrange the pelican on your T-shirt and fuse in place following the instructions for your double sided interfacing. Position fish inside the pelican's beak and fuse in place. You may want to use a pressing cloth to protect your fabric.

5 Slip the stabiliser inside the T-shirt, under the pelican and pin in place.

6 Sew the pelican and fish in place using a stretch stitch. For the pelican, we used a blind hem stitch and for the fish we used a long straight stitch close to the outside edge. (See Pic D.)

7 Pass your threads to the inside of the shirt and tie them off before trimming away any excess stabiliser from inside the T-shirt.

8 Sew button in place for the eye if you'd like to add one to complete!



WANT TO MAKE THE T-SHIRT TOO?

We recommend McCall's 7379 for boys and Simplicity 1785 for girls



Manchester



Birmingham

1000s of Rolls at Realistic Prices!

Stockists of all kinds of

- Fashion Fabrics
- Woollens
- Worsteds
- Polywools
- Polyesters
- Cotton
- Dance Wear
- Linings
- Bridal Wear
- Satins
- Suiting
- Lycras

and much, much more!



JOHN KALDOR
NEW LOOK

Leon's Fabric Superstore
419 Barlow Moor Rd
Chorlton Manchester M21 8ER
Tel 0161 881 7960

Barry's Fabric Superstore
1 Moseley Street
Digbeth Birmingham B5 6JX
Tel 0121 622 6102

www.leonsfabrics.co.uk

Quilters Dream

quilting embroidery



ROW BY ROW EXPERIENCE - TRAVEL AND COLLECT

How about this... it's like a shop hop, but it's not... no fees, no cards to stamp, and all summer to play! Simply visit any of the participating shops and receive a free pattern for a row in a quilt. Combine your rows in any way to create a unique quilt that represents the fun you had traveling throughout the summer. Travel with friends, discover new quilt shops and have fun collecting rows!

This is an international event. Starting June 21 - Sept. 6, 2016

Bring in your quilt from June 21.-Oct.31.2016 and win a prize log in for more info <http://www.rowbyrowexperience.com/>

We are on the First Floor (stair and ramp access plus stair lift) at Units 403-407,

The Commercial Centre, Picket Piece, Andover, SP11 6RU

t: 01264 324420

e: info@quiltersdream.co.uk

www.quiltersdream.co.uk

Open Tue-Fri 9.30-17.00 Sat 9.30-16.00



www.susiedesigns.co.uk

10% off
LOVESEW31

Bag-making & Sewing Supplies

Fabric | Interfacing | Hardware | Patterns | Tools | Kits

Everything you need to make bags and accessories you can be proud of, including fabrics by Dashwood Studio, Art Gallery Fabrics, Cloud9, Michael Miller, Tilda

Visit our shop: 58 Clerk Road, Penicuik, Midlothian EH26 9EY





AUTUMN SAMPLER QUILT COURSE NOW BOOKING

www.blackmountainfabric.co.uk

100% Cotton - Wool Felt - Batiks - Japanese Yarn Dyes - Linen Mixes - Dressmaking Fabrics - Kits - Accessories - One Day Classes - Textile Courses

29 Cross Street, Abergavenny, NP7 5EW
Monday - Saturday 10am-4.30pm
01873 858827
Find us on Facebook



Chrysalis FABRICS

The essential mail-order fabric subscription service for the professional and home dressmaker

Premium quality dress fabrics hand selected and presented in four seasonal swatch Collections sourced mainly from Europe. Order any quantity by phone, e-mail, post or fax.

Subscribe for only £18p.a with no obligation

Join today! Call Diana on 07748 530 318
Learn more at www.chrysalisfabrics.co.uk



Tiny turtle

RATTLE

This cute little turtle softie is a simple sewing project that makes a perfect gift for a newborn. It's filled with craft bells, which produce a nice soft jingle when shaken

Project **LAURA MINTER & TIA WILLIAMS**

Little Button Diaries

Photography **ALEX WRIGHT** teneight

Download
FREE
TEMPLATES



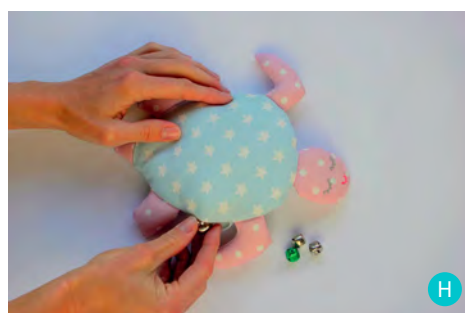

Skill level ♥

MATERIALS:

- ♥ FQ pale blue cotton canvas
- ♥ FQ pale pink cotton canvas
- ♥ grey & pink embroidery thread
- ♥ toy stuffing
- ♥ 4 craft bells
- ♥ air-erasable marker
- ♥ downloaded from www.love sewingmag.co.uk

How to make:

- 1 Use the templates to cut 2 body pieces from blue fabric. From the pink, cut 2 heads, 4 arms, 4 legs and 2 tails. (See Pic A.)
- 2 Use a fabric pen to lightly draw a face onto one of the head pieces – you can use the template for guidance. Note that there will be a ¼” seam allowance when sewn. Back-stitch the face with embroidery thread. (See Pic B.)
- 3 Pin the arms, legs, head and tail pieces RST and sew with a ¼” seam allowance. Once sewn, make snips in the excess fabric around the curve and cornered areas to prevent puckering.

4 Turn each piece RS out, using a point turner, crochet hook or a blunt pencil to gently tease out the corners. Stuff each piece and set aside. (See Pic C.)

5 Pin the legs, arms, head and tail onto the RS of one of the body pieces, facing inwards, with the fabric edges lined up. Make sure they are evenly placed with the legs and arms lined up with each other, then sew along the edge of the fabric to secure in place. (See Pic D.)

6 Place the body pieces RST, with the sewn one on top. Pin together, then sew around the body with a ½” seam allowance. Leave a 2½” gap along the side of the body to allow you to turn out. (See Pic E.)

7 Make snips as before to prevent puckering, then turn RS out. Press the seams lightly if you like though this is not essential. (See Pic F.)

8 Stuff the body and add the bells, pushing them into the centre so that they are cushioned by the stuffing. (See pics G and H.)

9 Slip-stitch the hole closed to complete! (See Pic I.)



WE USED



Cath Kidston Blue Star and pink spot cotton duck, www.cathkidston.co.uk



Maud's Fabric Finds

Specialist in French textile
and hand printed fabrics

Now stocking a large range of chambray, cotton lawn
and knits

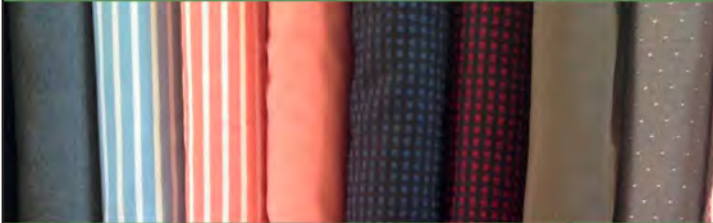

15% OFF!

AT CHECKOUT ENTER
sewing15



www.mauds-fabric-finds.com

LINTON DIRECT

The world's most innovative fabrics



Linton Tweeds design and weave luxury fabrics
for the world's most exclusive fashion houses



See our website for the Linton Direct collection

Use discount code
lovesewing10

www.lintondirect.co.uk

Sewing Patterns by Sewing Belle



www.sewingbelle.co.uk

Our website offers a full range of sewing patterns including Simple Sew,
Vogue, Butterick, Kwik Sew, Simplicity, New Look, McCall's & Burda
15% off your order quote SB15



Temptations Craft Boutique

An Aladdin's cave full of fabrics
including Moon Tweeds
100% Cottons for Patchwork and Quilting
Knitting yarn and haberdashery
Courses and workshops
Agents for Brother Sewing Machines

Visit our shop or buy safely online
31 Main Street, Bentham, North Yorkshire, LA2 7HQ
Tel: 01524 261 868

www.temptationsbentham.co.uk
For shop opening times, please see our website

Jaycott's
EST. 1920

YOUR FIRST CALL FOR
**SEWING
SUPPLIES**

**FREE MAIL
ORDER CATALOGUE**
CALL: 01244 394 099
GO ONLINE
JAYCOTTS.CO.UK
OR VISIT OUR
CHESTER STORE

JAYCOTTS LTD, UNIT D2,
CHESTER TRADE PARK, BUMPERS LANE,
CHESTER CH1 4LT 01244 394 099

Stitcher OF THE YEAR?

It's with great pleasure we can announce the winners of our first Stitcher of the Year competition. We'd like to thank everyone who entered – we were completely amazed by the skill and talent of our readers

JANOME

Over £10,000
of prizes!

Don't forget to head to www.lovesewingmag.co.uk to see all the winners makes and more of our fabulous entries!

Stitcher of the Year Category

- Penelope Barton has gone above and beyond to create historically accurate garments for a recent Tudor festival.
- We loved Rebecca Derbyshire's Moana top by Papercut Patterns with its sweet horse print.
- Alex Howard is looking like she's walked right out of the TV show Mad Men in her wool Joan Dress by Sew Over It.
- Sue Morley's pieced Linton Tweed jacket blew us away with its technical features and level panel placement. We're sure she's proud, every time she wears it.
- Sue Grover has two things to celebrate – her Ruby wedding anniversary and completing this fabulous three-piece outfit! What clever use of tartan for her Scottish celebration.
- Aimee Hilton is a relative newcomer to sewing but her take on a modern dungaree dress is finished wonderfully.
- It seems Patricia Torrie may have mastered toy making with an intricate and detailed unicorn toy for her granddaughter.
- Linda Claxton couldn't find the shirt she wanted in the shops so she merged two together to create her perfect colour-blocked garment.
- Ann Gill wowed us with the bridesmaid dress she made for her daughter to wear to her son's wedding! It's clear a lot of

time, effort, love and pride went into this project.

- The level of detail Lorna Richardson has achieved in her embroidered dog portrait was simply spectacular.

Home and Accessories Category

- Karen Rowe can't stop making these bags as gifts for her friends and family! We love that she used a Love Sewing tutorial to make them all.
- Quick off the mark, Carol Clancy made her memories into a cushion using the Hands-on Cushion tutorial from issue 30.
- Kim Newton created a striking and colourful tuffet using 64 strips of Kaffe Fassett fabrics.
- Lindsay Evans' fun fox curtains entertained us and her ingenious idea was to use bunting for the curtain tie!
- Faye Dearnley couldn't bear the small scraps of her stag fabric being thrown away (it's so cute) so she salvaged them and made a clever clutch bag.
- Helen Craggs put her creative juices into action to create a dressmaking-themed peg bag as a gift for her friend!
- Lorna Abrahams has made the perfect messenger bag for the anglophiles among us using London-print canvas creatively.
- Lorraine Sturdy dressed up her mum's caravan with this charming bunny bunting using a tutorial from an early issue of Love Sewing!

- Despite never making a quilt before or attempting appliqué, Kathryn Bryce made a stunning quilt as a wedding present for her son and daughter-in-law.
- Elaine Martin certainly knows how to create perfectly paired presents; she created a string of bunting and a co-ordinating triangle-pieced cushion as a flat-warming gift!

Children's Makes Category

- Rebecca Woodward made her daughters matching playsuits for their trip to Florida with Disney print fabric panels.
- Fiona Pullen sewed some great cargo shorts for her son, which he's certainly been putting to the test!
- Jeanette's fabulously scary pyjama cases were made using a Love Sewing tutorial and upcycling a pair of curtains.
- Jolene Jacobson transformed a shop-bought skirt into an adorable printed top for her niece.
- Maria Burns and her sister Esther Keown entered this impressive lion quilt into the competition. Esther designed the pattern and Maria brought it to life.
- Pat St Ledger has made scrap busting stylish with this version of Simplicity 1470 using different shades of pink cotton.
- Jane Parker made this charming bag using two of her husband's old shirts and a printed panel for her unicorn-mad daughter.

- Janet Bowden didn't just make one doll; she made a whole army! We love that each one is customised for its owner.

- Shana Roche is one clever cookie. She worked out how to make an Elpheba witch doll inspired by the musical Wicked.

- Diane Shaw has created a whole family of happy hippos for her granddaughters in bright coloured poly-cottons.

Simple Sew Category

- Jenny's Chelsea collection is absolutely fantastic and we know she'll get lots of wear out of these garments.
- Brenda Salmon has created a stylish outfit using two Simple Sew patterns by partnering her English Tea Dress with the Notch Collar Jacket.
- Angela Holland's graphic black and white skater dress definitely caught our attention. Not to mention the dramatic backdrop behind her.
- Alison Bunn is race-day ready in her fabulous Loretta dress!
- We're sure Luisa Andreou-Jones will get lots of wear from her gorgeous Bardot dress.
- Elizabeth Corcoran's botanical print Amelia dress sure did inspire us, even if her cheeky pooch doesn't seem as impressed.
- Sarah Wilson nailed vintage glamour with her Audrey Hepburn-inspired version of the ever-popular Ruby dress.

STITCHER OF THE YEAR

Aimee is a relative newcomer to sewing and with a good dollop of patience and perseverance she created her dream garment.



Rebecca's top is made in a horse-print cotton lawn and she added a hot pink lace zipper to the back.



Home and Accessories Category



64 strips of Kaffe Fasset fabric were used in Kim's colourful tuffet.



Elaine created a string of bunting and co-ordinating triangle-pieced cushion as a flat-warming gift!



Lorna's London-print messenger bag perfectly fits her A-Z!



Stitcher of the Year Category

We are in awe of the hundreds of hours of construction and embellishment in Penelope's costumes.

Talented sisters, Esther designed the lion pattern and Maria brought it to life.

Jolene's top for her niece features perfect print placement.

Angela's graphic black and white Skater dress definitely caught our attention.

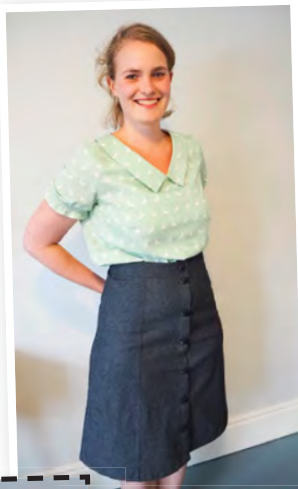

We know Jenny will get lots of wear out of her Chelsea collection.



Children's Makes Category

Elizabeth's botanical print Amelia dress was made with fabric bought on holiday.

How adorable is Janet's army of customised dolls?

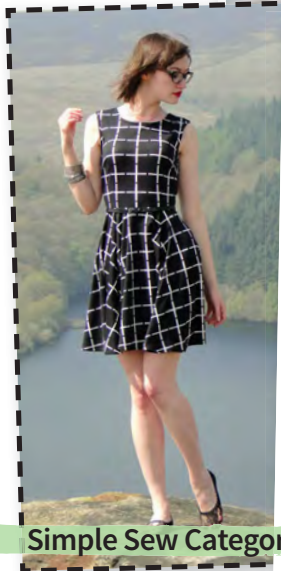

Simple Sew Category



Who won our selfie competition?

We loved seeing you all out and about with copies of our magazine, but we chose **Charlotte Powell** as our winner of the Grove's haberdashery prize for her fun picture out and about in Amsterdam!

Congratulations to Charlotte.



K
REMNANTKINGS

Fabrics, haberdashery,
patterns & inspiration
in-store & online at:

www.remnantkings.co.uk

Glasgow - Edinburgh
Falkirk - Hamilton

10% off at checkout using the code LOVESEWING31

Little Laura's
HABERDASHERY

15% off
with code
love15

Hundreds of fabrics
Notions and sewing accessories
Michael Miller Fairy Frost

www.littlelaurashaberdashery.co.uk

SIMPLY SOLIDS

Patchwork - Quilting -
Dressmaking - Classes

Stocking a rainbow of Kona
cotton solids, blenders &
notions

Now Open in Huddersfield
10am - 3pm Tues - Sat
Unit 104 Colne Valley
Business Park,
Linthwaite
HD7 5QG

Tel: 01484 766950

Discount
code:
LS29

Fabric
GODMOTHER

FABRIC
PATTERNS
HABERDASHERY

WWW.FABRICGODMOTHER.CO.UK

Couture Sewing with ALISON SMITH MBE

Matching stripes



For a truly high-end finish, you'll need to know how to pattern match striped fabric across the top of your sleeves. Help is on hand as Alison can show you the perfect approach to cutting and installing your stripy sleeves

I just love Breton style, but I know for many stripes are a fabric to avoid! It may be easy to match a stripe down a side seam but when it then comes to matching through a sleeve, people often choose the sleeveless option instead.

The most crucial part of matching a stripe fabric with a sleeve is the cutting out. Take your time and, if the pattern calls for fabric to be cut on a fold, then spend time making sure each stripe is folded onto itself. This is easy at the edges of the fabric, but can be more difficult 50 or 90cm in! Use lots of pins if it helps you. It also helps to mark your stitching lines on your pieces in air-erasable marker.

LAYING OUT

1 Pin the front pattern piece to the fold in the fabric, placing it carefully so that there is a stripe at the hemline and if possible a stripe at the side seam/armhole junction. Depending on the width of the stripe this may not always be possible.

2 Pin the back of the garment alongside the front so that the hem edge on both pieces is on the same stripe, this should bring the side seam/armhole junction on the same stripe as the front. Bust darts will unfortunately affect your stripe placement slightly but this is best hidden above the dart, under the armhole.

3 Once you are happy with the back and front its time to move onto the sleeve. You are going to match the sleeve from the armhole, down toward the hem to start with. If the stripes on the side seam of the garment and the sleeve seam match, then the stripes above this point must match. Pin the sleeve pattern piece onto the fabric so that the sleeve seam/armhole seam is positioned on the same stripe as the side seam/



armhole seam on the front and back pattern pieces. (See Pic A.)

4 The same stripe should be on the front and back edge of the armhole. Now look at the notches. The front notch on the sleeve should be on a stripe that corresponds to the stripe on the front armhole and the same for back double notch. (See pics B and C.) If you are using a jersey fabric you may be able to ease it into position. Now check the sleeve head, it should be falling on a stripe that corresponds to the shoulder seams on the front and back pattern pieces. Once you are sure all this is matching then and only then cut out.

STITCHING

5 You will probably find it easier to use a walking foot to sew stripes. Stitch the side seams first, matching the stripes – remember to match them on the stitching line not just the cut edges. Then stitch the shoulders; again if possible match the stripes through the shoulder seam to give a chevron effect. (See Pic D.)

6 Make the sleeve seam, matching the stripes. If you are using a woven fabric you will need to stitch two rows of ease stitches through the sleeve head. If you are using a jersey fabric then ease stitches may not be necessary.

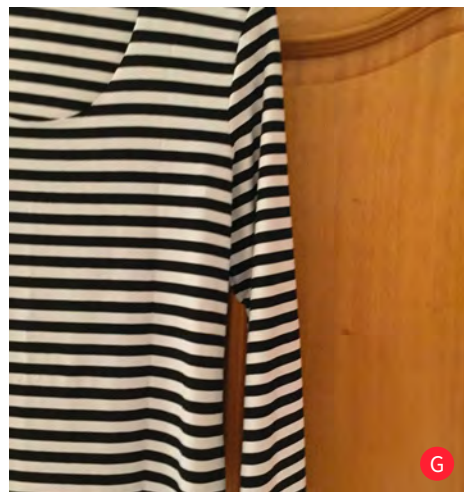
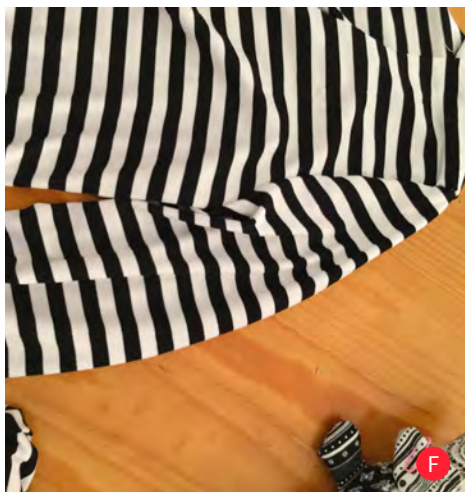
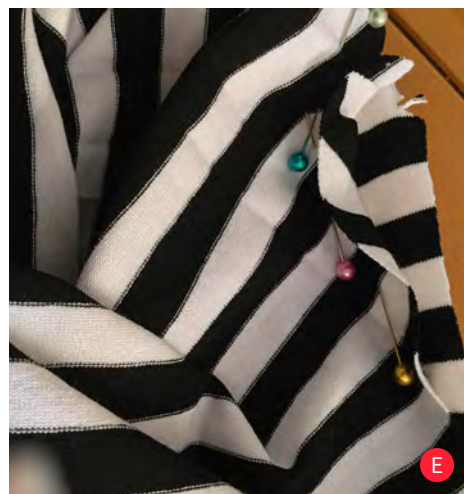
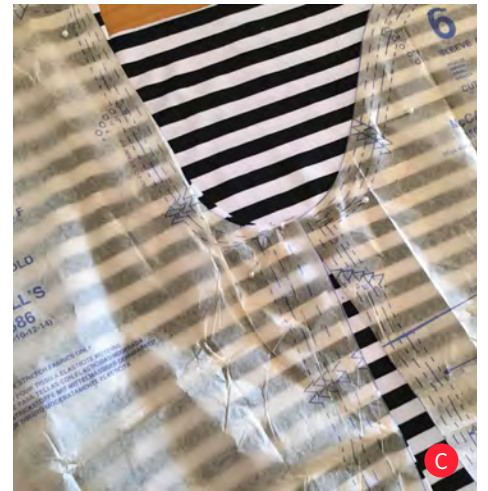
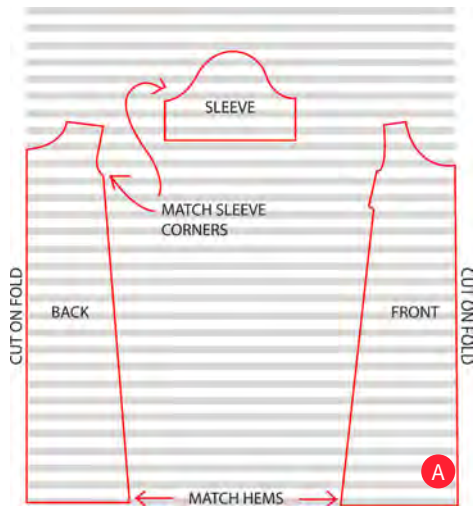

7 Pin the sleeve into the armhole, starting by matching the sleeve seam stripes to the side seam stripes on the dress/top. Now match the stripes through the notches, again matching on the stitching line not the raw edges. Keep pinning the sleeve into the armhole, but the closer you get to the sleeve head the more difficult a perfect match becomes, as the armhole on the garment is cut relatively straight and the sleeve is cut on a curve. (See pics E and F.)

8 The stripe at the sleeve head should be the same as the stripe on the end of the shoulder seam. (See Pic G.)

These instructions are your introductory lesson in pattern matching. For plaids, checks and tartans these basic principles will apply but more in-depth matching will be required.

Alison



A brief history of
**BELL-BOTTOMS AND
BEACH PYJAMAS**

*In her book **Nautical Chic**, Amber Butchart traces the relationship between maritime dress and the fashionable wardrobe by evaluating the officer, sailor, fisherman, sportsman and pirate. In this issue, we asked her to share the history of classic wide-leg trousers*



Throughout the 18th century, working seamen wore trousers while men of fashion wore breeches. This was a question of practicality, as working men needed more ease of movement, and it became a clear marker of class. The initial sailor trousers were fairly wide and stopped just above the ankle. In 1813, the first mention of bell-bottoms occurred when the US crew, under Commodore Stephen Decatur, appeared in New York 'dressed in glazed canvas hats with stiff brims decked with streamers of ribbon, blue jackets buttoned loosely over waistcoats, and blue trousers with bell bottoms'. The term bell-bottoms stuck even though the 'flare' was not always extensive; the 1894 US regulations noted an increase of only one inch between the knee and the cuff. Bus size was irrelevant as the distinctive wide trousers became indelibly linked with sailors in the popular imagination.



Wide trousers first entered women's wardrobes courtesy of Coco Chanel. She wore beach pyjamas as early as 1918 and, throughout the following decade, wealthy women adopted pyjamas when holidaying by the sea. Chanel's early version was modelled on the line of male pyjamas, but the influence of the navy was soon apparent on designs such as the set she wore from 1929, which consisted of loose white trousers with a white double-breasted jacket, reminiscent of a modified pea coat or blazer. White, the colour of the sailor's summer uniform, easily transitioned into holiday wear for women at the coast. Later sportswear designers, such as Jane Regny, widened the legs and turned beach pyjamas

into jumpsuits. In 1925, *Vanity Fair* reported that extravagantly-patterned beach pyjamas were all the rage for men at Deauville in France and at the lido, and Schiaparelli launched her own knitted version in 1928. According to local news, the Riviera town Juan-le-Pins became known as Pyjamaland due to the popularity of this look. The connection with sailor style persisted and, in 1931, British Vogue were advertising wide-legged 'woolen suits for the beach' including 'Le Matelot', 'in navy blue and white stockingette' [sic]. Throughout the 1930s, the styles spread further and could be seen lining the beaches of Britain, although trousers for women remained somewhat taboo outside of



"Wide trousers have a timeless appeal that sees them equally popular whether interpreted as chic classic or playful holiday wear"

A BRIEF HISTORY OF BELL-BOTTOMS AND BEACH PYJAMAS

the relaxed dress codes of the beach or the privacy of the home until later in the century.

Bell-bottoms found favour again through military surplus outlets in the early 1960s. An article in *Esquire*, June 1966, noted that they were an important addition to a man's wardrobe in denim or cotton duck, or 'the real article, a pair of white-cotton regulation Navy bell-bottom pants'. From early in the decade, students in London and across the States scoured army and Navy surplus outlets for cheap clothing that was worn on the streets and campuses with a certain anti-establishment insouciance. This held a strong interest for iconoclastic designer Yves Saint Laurent, whose visit to Kaufman's Army & Navy surplus store on 42nd Street in New York sparked his 1966 collection that ultimately established the pea coat as a fashion classic. The collection also featured bell-bottoms, an element that *British Vogue* picked up on in July 1966 with the shoot 'Vogue's Sea View', featuring 'total nautical looks inspired by Saint Laurent'. Bell-bottom hipster trousers were photographed at Cannes on a society yacht.



Elsewhere in the issue, Jean Shrimpton was shot by David Bailey for an article titled 'Sea Change for Crepe', which included 'wide white sailor trousers' by Susan Small. By 1973, flared pants were the dominant silhouette for both men's and women's trousers. *British Vogue* shoots began to resemble 1930s beach scenes, with wide, white, cotton trousers a regular feature.

"By 1973, flared pants were the dominant silhouette for both men's and women's trousers"



Flares were ubiquitous, epitomised in a shoot called, 'Deauville, Trouville out in the Sunshinesville', photographed on a boardwalk and featuring London-based labels like Bus Stop and Mr Freedom. Bell-bottoms may have been ever-present but their nautical origins weren't forgotten.

Sailor pants remain popular as an evening look in dark navy and equally as a summer resort favourite in sharp white. Givenchy by Riccardo Tisci revisited them in autumn/winter 2007, complete with high waistline and flared leg. For spring/summer 2009, D&G went into Riviera overdrive, with white, blue and striped flap-fly sailor pants in long or cropped lengths. Sailor trousers were rendered as their trademark bloomer shorts in a collection that even referenced Chanel's part in the history of nautical style with bouclé suits



and beach pyjamas. Beach pyjamas have also been recreated in recent years by Marc Jacobs, whose reference point for spring/summer 2011 was distinctly 1970s-does-30s, with the requisite hint of disco and wide-brimmed sunhats. That season also saw wide palazzo-style pants produced by Thakoon and 3.1 Philip Lim. Wide trousers have a timeless appeal that sees them equally popular whether interpreted as a chic classic or as playful holiday wear.

How to... Read a dressmaking pattern

A guide to basic markings and symbols



PATTERN CUTTING LINE

Each line relates to different size for the garment. There can be up to 10 sizes on a pattern sheet so you can either follow a single cutting line throughout or blend carefully between sizes to achieve a better fit.

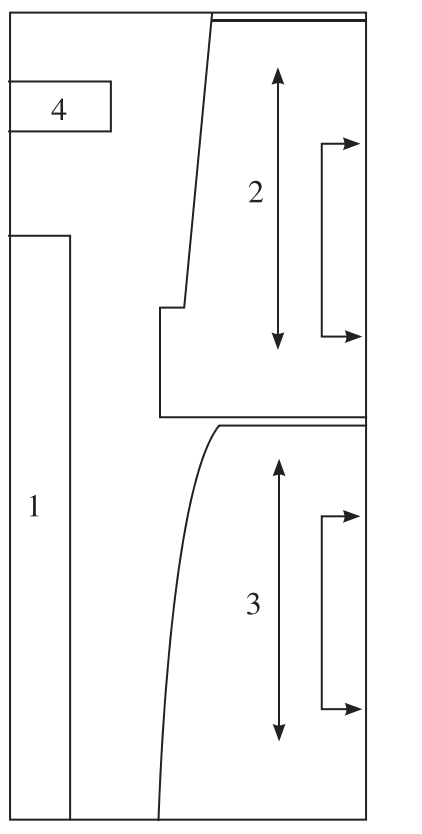

LAYOUT DIAGRAMS

These explain how to lay each piece onto the fabric to ensure that all of the pieces will fit on the fabric quantity suggested on the envelope. Remember to follow along with the correct view and size. Don't forget to take care with directional prints; you wouldn't want a floral print top with all the flowers upside down.



GRAINLINE

The arrow on the pattern piece must be 'on grain' with the threads of the fabric so that it can hang, move and stretch correctly. The grainline must always be parallel to the selvedge (the self-finished edges) of the fabric.



PLACE ON FOLD LINE

This edge of the pattern piece is to be placed on the fold of your fabric, making it easy to cut out a mirror image at the same time.

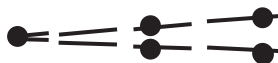

DARTS

Parts of the fabric to be folded for shaping, usually located at the bust, waist and neck.



NOTCHES

Make a tiny snip or chalk mark at each notch location, within the seam allowance. These marks are used to match pieces together before sewing.



LENGTHEN OR SHORTEN LINE

This indicates exactly where to shorten or lengthen the pattern piece or garment to make changes for improved fit.



CIRCLE DOTS

These marks indicate construction details, such as zipper position, pleating, or the end-of-stitching line, as set out in the instructions. Some pattern companies will use triangles or squares in place of circle dots.



BUTTON & BUTTONHOLE PLACEMENT

The placement for a button is marked with an X. The placement for a buttonhole is marked with an edged line.

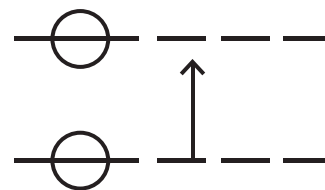

TUCKS/PLEATS

Transfer any tuck lines marked on the pattern pieces to the RS (right side) of the garment. Follow directional arrows where given.

ABBREVIATIONS

SA (SEAM ALLOWANCE)

Every project you sew has a set seam allowance. This is the distance between where you sew and the raw edge of the fabric – essentially an invisible line around each pattern piece. These lines are occasionally included on vintage patterns. You must sew at the seam allowance in order for the pieces to line up correctly. Most commonly this is 1.5cm, but check your instructions in case smaller allowances are being used. Sewing machines have marks for the seam allowance to the right side of the presser foot.

RS (RIGHT SIDE AKA FABRIC FRONT)

Instructions for placing right sides of fabric together will be written as RST.

WS (WRONG SIDE AKA FABRIC BACK)

Instructions for fusing interfacing to the wrong side of fabric will be written as WST.

PRESSED FOR TIME

Irons are integral for the accurate pressing of seams and hems, and of course, smoothing out creases! This month we're picking out some of our favourites

BEST FOR STEAM GENERATION

Rowenta DG8960 Silence Steam Generator

Steam generators are a more powerful option than your traditional steam iron, speeding up garment pressing and targeting the most stubborn of creases. Unlike many steam generators, the Rowenta Silence Steam Generator prides itself on being surprisingly quiet, so you can happily stand at the ironing board enjoying your favourite TV show or music without being interrupted.

Thanks to the 1.5 litre water tank beneath, you can use the iron for up to two hours without having to refill it, making it a great timesaver. Plus, the handy Calc Away system collects the limescale found in hard water, protecting your fabric and prolonging the life of the water station. While it may be bulkier than your standard iron, the cord attaches neatly to the base and all parts are contained for easy transportation and storage.



£150



£60

BEST FOR COMFORT

Morphy Richards Eco ComfiGrip 301011

With a unique ergonomic shape, this stylish iron from Morphy Richards allows you to get through piles of pressing and ironing comfortably without any annoying wristache.

A safe and practical model, it features a soft grip rubber handle, a handy 25m cord and an automatic shut-off system. The ComfiGrip 301011 boasts a wide range of accurate temperature settings to suit a variety of fabric types, and we're big fans of the Eco Switch, which allows you to save up to 23 per cent energy when ironing and using the steam function, while maintaining a powerful performance.



£70-80

BEST FOR PRECISE PRESSING

AEG DB6120-U Precision 4 Safety Steam Iron

An iron is a must-have tool for the sewing room, but it can also be a dangerous item to have around the home, especially if you have kids running about.

The DB6120-U has been developed with safety in mind and, when left in its unused, upright position, it will shut off after eight minutes and the safety light guide lets you know its current status. This means there's no need to worry about leaving home without unplugging the iron! There's also a large safety stand included, with a rubber heel, reducing the risk of knocking the iron over, especially when not in use.

We love the precision nose, which can reach even the most difficult areas of your garment, and the scratch-resistant 500 steam hole soleplate and powerful steam output make this a brilliant all-round iron for dressmaking and everyday ironing.



Under £30

BEST BUDGET BUY

Philips Easy Speed Plus GC2040/20 Steam Iron

This easy-to-use lightweight iron is perfect for sewists on a budget who are looking for a basic all-round option.

With a pointed tip, you can accurately press tricky areas such as between pleats and around button plackets and collars. Plus, the non-stick coating on the soleplate and even heat distribution means the iron glides effortlessly across fabric, making everyday ironing a breeze!

After filling the 270ml water tank, you will have 30 minutes of continuous steam, and unlike some of the more basic irons on the market, the Philips Easy Speed Plus boasts vertical steam, allowing you to easily remove creases from hanging fabric.

www.nataliamarati.co.uk
Tel: 07739656907

Art of pattern making
NA fashion school
Classes for all abilities

Sew Me Something

PATTERNS

FABRIC

WORKSHOPS

3 The Minories, Stratford upon Avon, CV37 6NF 01789 330588
www.sewmesomething.co.uk

The Midhurst Sewing Room

BLOOMSBURY SQUARE
FABRICS OF DISTINCTION

Dressmaking workshops for beginners and those wishing to improve their skills. Beautiful fabrics for your handmade clothes

www.claire-tyler.com
07771882903

www.bloomsburysquarefabrics.com
07919307844

2/5 The Administration Building, The Wharf Midhurst, West Sussex, GU29 9PX

Love Hector's Emporium
lovehector.co.uk
alison@lovehector.co.uk
Market Place, Crich, Derbyshire, DE4 5DD

We source: fabrics from UK and Europe
We teach: beginners to tailoring
We are: a specialist dressmaking shop

Hector Loves Sewing™

Quality fabrics & haberdashery

Flo-Jo

We sell a lovely collection of designer cute and quirky fabrics for the creative sewer. Including Liberty tana lawns, organic cottons and specialist knicker elastics.

fabrics workshops sewing accessories unique gifts sewing parties

www.flo-joboutique.co.uk
36b Gloucester Road, Bristol, BS7 8AR Tel: 01179041498

SASSY SEWING

A new kind of sewing shop

A huge range of hand-picked fabrics
Quality quilting supplies
High Class Haberdashery
Workshops and sewing retreats
A warm welcome and friendly, knowledgeable staff - always

8 The Market Place, Horncastle, LN9 5HB
Under the archway, between Age UK and the locksmiths
www.sassysewing.co.uk
01507 524566

sassysewingshop

Sew Charming

1 Shambles Court
Bell Street
Lutterworth
Leicestershire
LE17 4DW
Tel: 01455 556287

Extensive Range Of
Fabrics, Haberdashery,
Needlecraft Accessories
& Sewing Workshops

www.sewcharming.co.uk

Sewing workshops

Book yourself in to one of this month's top workshops and expand your sewing horizons!

Fabric HQ

Stoke Mandeville

Buckinghamshire shop Fabric HQ hosts lots of workshops in its light and spacious Make HQ Studio. Whether you're new to sewing, getting back into it, or are an accomplished sewist, get along to a class!

www.fabrighq.co.uk

21st September

Inserting a zip

Conquer that zipper phobia! In this session tutor Sam will guide you through inserting standard, invisible and lapped zips as well as explaining when and where to use each of these different techniques.

Cost: £33

27th September–18th November

Tricks of the trade

Get the basics right with our patchwork and quilting Tricks of the Trade series – pick and mix from the following workshops: rotary cutting, piecing, triangles, basting, binding and hand quilting.

Cost: £20 per session

1st & 15th October

Re-make a pre-loved garment

Do you have a special piece of clothing you wish you could bring back to life and enjoy once more? Well now you can! Tutor Lydia Quilter shows you how to recreate a pre-loved garment whether it's worn, new or old.

Cost: £145

8th & 22nd October

Sewing machine start-up

Our popular sewing machine start-up session is back! Perfect for complete beginners or those who have lost their confidence.

Cost: £70

From 3rd November

Pattern cutting: bodice block 1

Lydia Quilter shows you how to create a custom-fitted pattern bodice 'block' from which you can then create unlimited variations that are guaranteed to fit your unique shape every time.

Cost: £175

12th & 26th November

Roman blinds

Learn to make top-notch Roman blinds, finished by hand like a professional. Create your blind, learn how to measure up a window and get to grips with the tricky business of pleat calculations.

Cost: £78

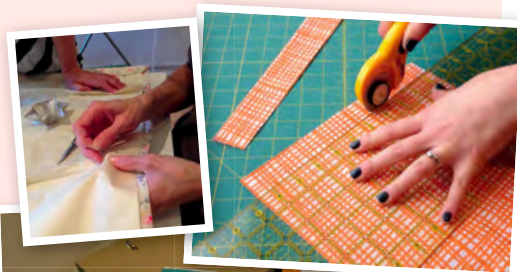

Purple Stitches

Basingstoke, North Hampshire

Meet Basingstoke's only modern fabric and haberdashery shop. It is packed full with designer fabric and quality haberdashery. Plus, it also runs regular sewing evenings and workshops.

www.purple-stitches.com

8th & 15th October

Sew a Christmas runner

Over two Saturday afternoons, you will learn all the techniques for making a patchwork runner, from design, cutting, machine piecing and basic quilting. If you sew with Christmas fabric, you will leave with a beautifully handmade runner ready to be the centrepiece on your Christmas table. Suitable for patchwork beginners.

Cost: £45

8th November

Christmas gift sewing

– Christmas stockings

Learn to sew the perfect gift for Christmas! Sew functional, decorative and personalised Christmas stockings. Also take home the pattern, so you can make one for all the family.

Cost: £25

16th November

Sew an Advent calendar

Learn to sew an Advent calendar, and get ready

for the Christmas countdown. Learn to make this fantastic calendar using pre-printed panels and personalise it for yourself or your recipient! All materials included.

Cost: £35

17th November

Make a lampshade

A lampshade is the ideal way to make a statement in any room. Learn to make a 30cm diameter lampshade from scratch. This is not made from a kit but individually designed and hand finished. Join the class and let your creativity flow.

Cost: £35

2nd & 4th Thursday evening of every month

Sewcial Evening

Bring along a sewing machine, a project and sew with fellow sewing enthusiasts over teas, coffee and biscuits. You will have full use of our equipment and the big cutting table too.

Cost £5 per session



Stitched by You

Alton, Hampshire

This fabric and haberdashery runs a varied calendar of workshops. Its highly skilled, passionate tutors pass on their love for crafts in an informative and easy way and provide you with the confidence and inspiration needed to continue.

www.stitchedbyyou.co.uk

17th & 18th September

Pictorial machine embroidery weekend workshop

Learn the mysteries of free-machine embroidery. Translate a drawing or photo into your very own embroidery piece.

Cost: £150

29th September

Introduction to hand sewing

Gain confidence with hand-sewing techniques and learn how to handle fabric and finish projects with lovely neat stitches. You'll go home with a lovely jewellery roll. Suited to beginners and refreshers.

Cost: £35

5th October

Know your sewing machine

This class is perfect for absolute beginners, covering how to thread and operate a sewing machine along with tuition on basic stitching techniques. You'll make a simple tote bag to take home.

Cost: £35

22nd October

Get sewing with Mum or Dad

(ages 7+)

Have fun working as a parent and child team to create a beautiful boxy zipped bag to take home with you. You'll learn the techniques you need and then together you'll create your masterpiece!

Cost: £25

25th October

Introduction to hand stitching

(ages 7+)

This is a brilliant first hand-sewing class for children. You'll use fantastic Kitty Kay felt kits, and each participant will leave with a completed project, whether it's a bird, dog, owl or dinosaur!

Cost: £25



29th October

Christmas stockings (ages 10+)

This class is for children who have used sewing machines before and want to have a go at a new project. Christmas is the best time to get creative, so get stuck into making your very own stocking!

Cost: £35

Teach Me To Sew

Stansted, Essex

This independent sewing school offers a variety of classes for adults and children. Class numbers are kept low in order to ensure that you receive plenty of attention, and for those who are more serious there are also City & Guilds accredited courses on offer!

www.teachmetosew.co.uk

Commencing 28th September
(9 sessions)

Sewing machine skills City & Guilds level 1

In this comprehensive sewing course, you'll learn and understand all aspects of your sewing machine and complete a folder of samples, learning around 28 techniques including buttonholes, zips and piping.

Cost: £340, instalments available

Commencing 29th September
(10 sessions)

Sampling fashion techniques City & Guilds level 2

This course is for students with intermediate sewing skills who wish to develop further, and covers more complex techniques including welt pockets, Rouleau loops, facings, beading and much more.

Cost: £380, instalments available

Commencing 30th September
(10 sessions)

Lined curtain with tape heading City & Guilds level 1

A fantastic course for those who would like to make professional, bespoke handmade lined curtains. Over the 10 sessions you'll complete a pair of full-size lined curtains to fit your window and produce a portfolio of notes and samples.

Cost: £380, instalments available

Commencing 6th October
(9 sessions)

City & Guilds level 2 dress course

Perfect for students with intermediate sewing skills looking to learn more complex techniques in order to make a quality garment, while also completing a portfolio and contextual fashion research.

Cost: £486, instalments available

15th October

Learn your way around a sewing machine

In this class for complete beginners, you'll learn how to thread and use a machine, sample different stitches, grasp what each attachment is for and whatever else your sewing machine has to offer. You'll also do some sample stitching with a zip and buttonholes.

Cost: £60

22nd & 23rd October

Make your own personal dressform

Join this class to spend a fun two days wrapping and being wrapped to make a personal dress-size tailor's dummy that is a replica of your body! The class cost includes a wooden stand. You will need to be able to stand for 2-3 hours at a time.

Cost: £170



Book Now for Summer!

- Dressmaking Classes & Sewing Workshops
- After School Sewing club
- Creative Parties
- Summer workshops for Kids and Teens
- Special Weekend Workshops

Dot to Dot Studio
Village Works
East Hoathly
East Sussex
BN8 6QA

01825 841311

DOT to DOT
studio
www.dot to dot studio.co.uk



117 Townhead
Kirkintilloch, G66 1NX
enquiries@isew2.co.uk
0141 777 6633

f isew2 t isew_2

Contemporary fabrics, quilting supplies,
yarns, haberdashery, Elna sewing machines.

Sewing, knitting & crochet classes
- see website for details

www.isew2.co.uk



HOLLIES HABERDASHERY
11 BARRACKS COURT, BARRACKS ROAD,
NEWCASTLE UNDER LYME ST5 1LG
01782 610 241
WWW.HOLLIESHABERDASHERY.CO.UK

FOR 10% OFF USE CODE
Lovesewing10

"Your one stop sewing shop"

Jaylaur's
Sewing Studios

- ❖ Clothing Alterations & Repairs
- ❖ Fitting Room & Express Service
- ❖ Fabrics, Haberdashery, Patterns, Magazines, Books
- ❖ Crafts Fabrics & Fat Quarters
- ❖ Jelly Rolls, Charms & Layers

Stockists of: Riley Blake ❖ Michael Miller
Robert Kaufmann ❖ Makower ❖ Nutex ❖ Tilda
Fabric Freedom ❖ Gutermann Creative

SINGER SEWING MACHINES

Email: Jaylaur's54@gmail.com

Tel. 01652 650 047
54 Wrawby Street, Brigg DN20 8JE

f Join us on facebook at
'Jaylaur's Sewing Studios'

**NEW Autumn Workshop Timetable
Out Now!**

Head to katiemakes.co.uk for details!

Katie Makes
The Craft Space
making in the spirit of handmade

dressmaking, crochet, patchwork, hand embroidery, lace-making,
needle-felting, soft furnishings, parties, hen do's, private tuition ...

Trowbridge, Wilts - 01225 762554 - workshops@katiemakes.co.uk

sewcreative



Situated in the market town of Petersfield, Hampshire, Sew Creative stock fine fabrics, sewing accessories, haberdashery, Janome and Elna sewing machines and craft kits. If your sewing skills need refreshing or you require some creative inspiration, our friendly workshops led by highly skilled, enthusiastic tutors include dressmaking, quilting and homemaking, felt making and textile printing for every age from the absolute beginner to the confident sewer.

Sew Creative, 20-22 Lavant Street, Petersfield, Hampshire, GU32 3EW
web: www.sewcreative.org.uk email: info@sewcreative.org.uk
phone: 01730 858020 facebook Sew Creative - Fabric and Workshops

Sewgirl

Sewing Gift Kits | Workshops for Adults & Children | One-to-one Sessions



wholesale enquiries welcome

www.sewgirl.co.uk / info@sewgirl.co.uk

ADVERTISE ♥ ADVERTISE ♥ ADVERTISE

love Sewing

STYLISH SEWING MADE SIMPLE

To advertise please contact Nouné on
0844 826 0612 or email
noune.sarkissian@practicalpublishing.co.uk

ADVERTISE ♥ ADVERTISE ♥ ADVERTISE



DISCOUNTS & GIVEAWAYS

Pretty sewing goodies, patterns to win and a super discount to fill your fabric stash



WIN

a pair of tickets to Simply Christmas and Sewing, Stitching & Hobbycrafts

London, 17th - 19th November
We have teamed up with the organisers of the Simply Christmas and Stitching, Sewing and Hobbycrafts to offer 25 lucky readers a chance to win a pair of tickets to this fantastically festive show. The show, taking place at ExCeL, London 17th - 19th November 2016, will feature over 100 exhibitors offering the latest craft inspiration and advice.

With a festive mix of gorgeous craft materials, handmade Christmas gifts and decorations, live music and indulgent food and drink, Simply Christmas returns to the ExCeL this November alongside the Stitching, Sewing

and Hobbycrafts show. The perfect show for discovering handcrafted gifts, Simply Christmas is the place to bag gifts to wow friends and family before heading to Stitching, Sewing and Hobbycrafts to buy supplies to fuel your own creations.

More than 200 exhibitors will fill the aisles at the two shows, creating a paradise for those with a passion for creativity. From quirky stand-out gifts that can be personalised while you wait to festive food and drink, Simply Christmas will get you in the spirit of the season.

Visit www.ichfevents.co.uk for more details and all the latest information.



WIN AN AUTUMN SWEATER AND BAG BUNDLE FROM HANTEX

This month's project inspiration prize bundle from Hantex brings three lucky winners the perfect relaxed autumn combination – a super comfy sweater and a trendy bag to suit your taste. The winner will receive the sophisticated Finlayson sweater pattern from Thread Theory Designs, along with enough heathered fleece-lined sweatshirt fabric and striped ribbing to make up your own.

On top of that, each winner will get a Cooper bag pattern from Walden by Colette Patterns, which provides three different bags from one basic body, so you can pick your favourite and make it up in the denim and canvas that will also come as part of your prize bundle. Even the finishing touches are included – webbing, magnetic snaps, tubular rivets and metal adjusting buckles.

Each bundle is worth £160 so enter today to have a shot of winning one for yourself! To find more fabulous inspiration from Hantex and to find your nearest stockist, check out www.hantex-europe.com/threadtheory

PRIZES WORTH £480!



THREAD
DESIGNS INC.
THEORY

Colette
PATTERNS

WIN a set of Prym Espadrille goodies

We've some fabulous bundles of espadrille-making supplies to give away this month. For adults there's prize sets to get your hands on with all you'll need to make three pairs for yourself or for loved ones, one set in size 38 (UK 5) and one in 39 (UK 6). We also have a kids' bundle up for grabs, with four fabric packs, soles and more to make up some super cute pairs in size 26/27 (UK 8/9) for any little ones in your life. To find your nearest stockist of Prym products, check out www.hantex.co.uk



To enter, go to www.ppjump.com/lovesewing31
Closing date: 13th October 2016
By entering these competitions, you accept your email address may be passed on to sponsors for marketing activities

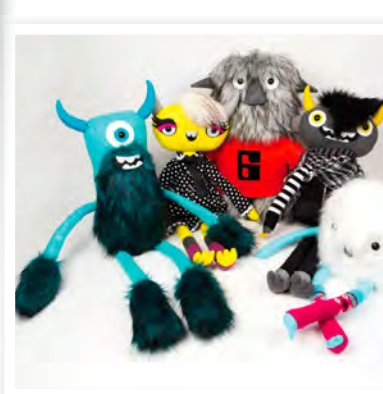

35% off Make Creatures with Felt Mistress

Grab your copy of the fabulous new collection of weird and wonderful characters from Felt Mistress with 35% off code **FELT35** when you check out at www.laurenceking.com!

WIN 10 metres of Jane Makower INPRINT fabric

One lucky reader this month will be able to get their hands on a fabulous bundle of fabric from Jane Makower's Sports Story range of INPRINT cottons, with the winner receiving a metre each of the collection's 10 original and striking designs. Tiny characters ride across the fabric in tandem, accompanied by a selection of stitch check fabric in different shades.



WIN a pair of Clover thread and bobbin towers

Get your thread in order with a storage prize set from Clover. With the Stack 'n Stitch Thread Tower, worth £17.99, you have a thread tower capable of storing up to 30 spools and which doubles up as a thread guide. As for your bobbins, the Stack 'n Store Bobbin Tower makes light work of keeping them tidy and organised with thread ends secured so you can avoid tangles and fuss. Clover products are available nationwide from all good craft, sewing and hobby shops. For stockist information, contact Clover at clover@stockistenquiries.co.uk



CODE: LOVECAPEL

10% off Capel Liberty Tana lawn at www.sewbox.co.uk

Add some gorgeous Liberty Tana lawn to your stash with a 10% discount on Capel fabric at Sewbox, an online purveyor of sumptuous fabric, patterns, supplies, kits and much more. Capel is gorgeously soft, drapes beautifully and is light and silky to wear, and you've got red, mauve, turquoise and pink to choose from. Simply enter the code **LOVECAPEL** when you check out at www.sewbox.co.uk by 20th October!

www.sewbox.co.uk

THE SEWING SHOP

Cheshire



Sewing Workshops based in Sandbach, Cheshire Classes available:-

'Beginners and Advanced Classes'
'Get to grips with Zips'
'Make a Tote Bag'
'Get creative making a Cushion'

Contact Mandy on 07772684907 or email: info@sew-stitch-creat8.co.uk

www.sew-stitch-creat8.co.uk
2 May Cottages, Sandbach, Cheshire CW11 4SD

North Devon

Shirmart Crafts

For all of your cardmaking, jewellery, knitting, crocheting and sewing needs.



77 High Street
Ilfracombe
Devon
EX34 9NQ

Open 6 days a week.

07976 603823
01271 268353

North Devon



11-12 George Arcade, South Molton, Devon, EX36 3AB, 01769 574071

Patchwork and quilting supplies. Classes and workshops.

Open 9am - 5pm Monday to Saturday
www.stepbystep-quilts.co.uk

Hampshire



SEW BUSY

Stockists of Michael Miller, Riley Blake, Makower, Staf, Tilda, Robert Kaufmann, Dashwood and others. Buttons, haberdashery, patterns, unique gifts and craft workshops.

Branksomewood Road, Fleet, Hampshire GU51 4JS

Tel: 01252 444220

www.sew-busy.co.uk

Wigan



THE SPINNERS WHEEL

Dress Fabric - Patterns - Haberdashery

Sewing lessons available

60a Park Road, Wigan WN6 7AA

Friendly help and advice

telephone - 07974 110161

Vintage style dresses made to order

www.facebook.com/spinnerswheel

Stansted Essex



Teach Me to Sew

Sewing Classes for all

11 Brook Rd Stansted

CM24 8BB

www.teachmetosew.co.uk

tel. 07752209936

Somerset

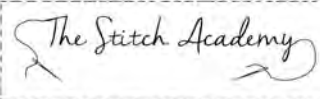

Sewing classes/workshops for adults and children

Registered Kids Can Sew® instructor

www.thestitchacademy.com

info@sewchet.com

01963 32608

Facebook - The Stitch Academy

Twitter - @sewchet

Merseyside

Stitchscape

A light and colourful space for stitchers of all kinds to enjoy some me-time, doing what you love, from quilts to vases to jackets. Workshops available and Sewcial sessions.

www.stitchscape.uk

diane@stitchscape.uk

www.facebook.com/stitchscape

Unit 2, Southworth Business Suites

Southworth Road, Newton-le-Willows,

WA12 0HS

01925 291953

Leicester

brother **crafty sew & so**

Shop, Sew, Create

All in One Space in the Heart Of Leicester

Workshops • Fabrics • Haberdashery •

St. Martin's Square Leicester LE1 5EW

CraftySewandSo.com
info@CraftySewandSo.com

Greater London

sew sew Fabrics

Sew Sew Fabrics, Bexleyheath Unit 4, Rear of 39-41 Church Road, DA7 4DD

We stock a variety of fabric from just £3 per metre. Come along to our showroom or check out our classes and events at: www.sewsewfabrics.co.uk/classes-events

Open Wed/Fri 9.30am-2.30pm and Tue/Thur 7pm-9pm

info@sewsewfabrics.co.uk
www.sewsewfabrics.co.uk

Hampshire

Reads of Winchester

Suppliers of sewing machines. Janome, Elna, Bernina, Toyota, Jaguar Both new and reconditioned.

Many machines on display demonstrations available.

Sales service repair haberdashery supplies

Tel 01962 850950

1 St Thomas Street, Winchester, hants SO23 9HE
Open Monday to Saturday 9am to 5pm

Buckinghamshire

Art Gallery Cloud9 Dashwood Studio 07761 957283

Kokka Makower Michael Miller Haberdashery Classes Mado Robert Kaufman Fabric Sevenberry Windham

fabrichq.co.uk

100 York Farm Old Baberough Rd Stone Mandeville MK35 5UJ
hello@fabrichq.co.uk

Harrogate

Duttons for Buttons

1956 - 2016

12,000 button designs

Haberdashery, ribbons, trimmings, needlecrafts and lots more

For mail order Duttons for Buttons, Oxford St.

Harrogate HG1 1QE

Tel. 01423 502092

e:michelle@duttonsforbuttons.co.uk

www.duttonsforbuttons.co.uk

www.facebook.com/DuttonsforButtons

Personal shoppers welcome Harrogate, York and Ilkley

Leicestershire

THE SEWING CAFE

Visit us at...
THE SEWING CAFE
for SEWING WORKSHOPS, FABRICS & HABERDASHERY

116 Castle Street, Hinckley, Leicestershire, LE10 1DD
01455 698034 | www.thesewingcafe.co.uk

Alton, Hampshire

Stitched By You

CRAFT WORKSHOPS & HABERDASHERY IN HAMPSHIRE

Fantastic courses for all levels over tea and cake in our well stocked shop. Enjoy textiles, sewing, crochet and more!

LEARN CREATE ENJOY

14 High Street, Alton, Hampshire, GU34 1BN

01420 544033
www.stitchedbyyou.co.uk

ADVERTISE

To advertise please contact Jane on 0844 826 0613 or email jane.bates@practicalpublishing.co.uk

ADVERTISE

FABRIC HQ *Stoke Mandeville*

This month we caught up with Rae, one half of the mother and daughter team that runs friendly shop Fabric HQ to hear a bit about what's going on



Tell us a bit about Fabric HQ's beginnings

My mum, Jacqui, had dreamed of owning a fabric shop ever since she started quilting in the late 80s and we both shared a massive love of fabric. When our collective personal stash reached crazy level, a flippant comment from my husband about having enough fabric to start our own shop was really all it took to convince us it was totally the right thing to do. That was five years ago and we haven't looked back!

What fabric do you stock? Any personal favourite brands or collections?

That is THE most difficult question to ever ask a fabric addict. We do love Dashwood – we're really excited about the new lot of fabric it's got coming out this season. We're also massive fans of Art Gallery Fabrics, and Cotton + Steel is high on the list too! My absolute favourite substrate to work with at the moment though is double gauze. I love the way it feels to wear and it handles so beautifully.

Tell us a bit about the workshops you run at the shop

Our aim with workshops is to try to get as many different types of class on our schedule as possible, so we don't just do quilting and dressmaking classes but a whole heap of other stuff such as bag, basket and lampshade making, free-motion embroidery and our pattern cutting classes are amazingly popular! We also run a series of technique classes for both quilting and dressmaking which are really handy.

What are the best and most challenging things about running a fabric shop?

The best is being able to share our love of fabric with other people! It's brilliant when people come in full of fantastic ideas and excitement about what they're about to embark on. It feels great to help someone choose that perfect fabric, or give some guidance to a newbie. The people are really what makes it special. One of the most challenging things

ironically is the lack of personal sewing time and also being sensible when we choose fabric and not buying it all. It's so tempting!

What's it like working as a mother and daughter team?

Being able to share this whole thing is so amazing! I don't think we ever dreamt that one day we'd run a business together but it is the best. You know you can trust that person 100% and having young kids to juggle means it's a real bonus when your business partner is your mum. Being mum and daughter also means we totally know which buttons to press and we can wind each other up terribly – but being family, you have to be able to get over it quickly.

Finally, is there anything exciting coming up that you'd like to tell our readers about?

Our 12 Makes of Christmas blog series begins early next month as well as an exciting project that we're working on with The Sewing Directory. We're about to celebrate our fifth anniversary which we're super excited about. We'll be having some special offers to celebrate and a big party to thank our amazing customers. Also watch out for details of lots of exciting new classes for the new year!



Fabric HQ
Layby Farm
Old Risborough Road
Stoke Mandeville
HP22 5XJ

www.fabrichq.co.uk
07761 957283

Sizes
6-14



NEXT MONTH IN

love Sewing

THE UK'S NO.1 SEWING MAGAZINE

YOUR FREE
Threadcount
PATTERNS
PATTERN
GIFT



3-in-1 dress pattern

With three easy-to-follow designs in one pack, this dress collection means you can create your perfect party look. Make in satin, cotton or viscose for three dramatically different styles

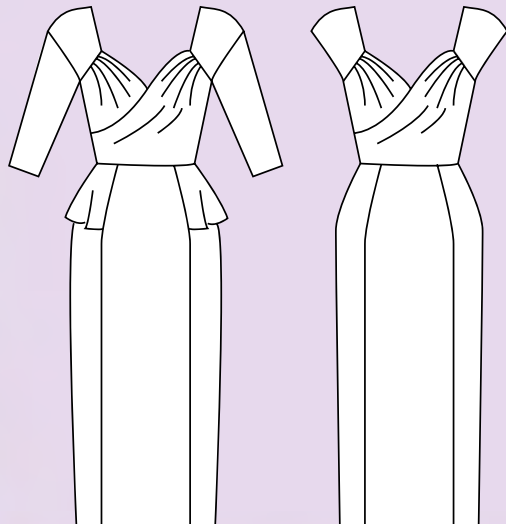

INCLUDES OUR
ESSENTIAL
CHRISTMAS
GIFT GUIDE

PLUS! CLEVER TUTORIALS FROM ELISALEX DE CASTRO PEAKE  TOP TIPS FROM WENDY WARD

**FIND
MORE
FREE
MAGAZINES**

[HTTP://SOEK.IN](http://soek.in)

SEE PAGE
32 TO
SUBSCRIBE

*Jersey
pyjama set*



Inspiring dressmaking, accessories and home projects:

- **Fun appliqué** make-up bag
- **Jersey pyjama set** for women
- **Cute kawaii** bag for kids
- **Free-motion embroidery** coasters
- **Kwik Sew** asymmetric skirt
- **Christine Haynes** explains fabric weave and texture
- **Learn to sew** your own jumpers!

FUN APPLIQUÉ MAKE-UP BAG



QUEEN OF HEARTS OUTFIT



TORIE JAYNE'S STYLISH CUSHION



EXPERT GUIDANCE FROM CLAIRE-LOUISE HARDIE  IN-DEPTH TECHNIQUES FROM ALISON SMITH MBE

30-minute make

FAUX LEATHER TASSEL

Make a keyring or bag tassel using this quick and fun tutorial

Project & photography

VICTORIA PEAT Little Black Duck

Skill level ♥

MATERIALS:

- ♥ scraps of faux leather
- ♥ Frixion marking pen or air-erasable pen
- ♥ ruler
- ♥ craft knife & cutting mat or scissors
- ♥ craft glue suitable for faux leather
- ♥ sewing clips
- ♥ View A – split ring and (optional) mini lobster claw

CUTTING:

Bag tassel

Cut from faux leather

- 13.5cm-wide x 9cm high rectangle
- 0.5cm-wide x 5cm long rectangle for hanging loop

Keyring tassel

Cut from faux leather

- 25cm-wide x 15cm high rectangle
- 1cm-wide x 28cm long rectangle for hanging loop

How to make:

1 Draw a horizontal line 2cm from the long upper edge. Next, draw vertical lines down from the horizontal line, each 5mm apart. Cut along each of vertical lines using a craft knife and metal ruler or a pair of scissors. (See Pic A.)

2 Apply glue to the short ends of the hanging loop and stick together. For View A, slip the split ring through the loop first. Secure with a sewing clip and allow glue to dry. (See Pic B.)

3 Apply glue along the upper 2cm uncut section at the top of the tassel. Position



Create a matching set!

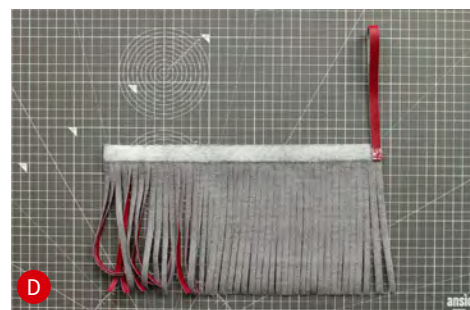

the hanging loop on the right-hand side of the tassel with the raw edges level with the horizontal line. Carefully and tightly roll the tassel, ensuring that the upper edge is kept level. (See pics C-F)

4 Wipe away any excess glue and clamp the ends of the tassel until the glue dries. Use binding clips or place under a heavy book. (See Pic G.)



For more information on local stockists contact **01793 834304**. Our latest brochure can be downloaded now from;

www.hornfurniture.co.uk

- ✓ Potentially huge surface, fully open (181cm/71¼ins by 100cm/39½ins) or half open for smaller projects—the choice is yours!
- ✓ Cupboards for storage *both* sides—one side with an adjustable shelf and the other fitted with removable baskets.
- ✓ Super sturdy! Extra stable construction with a double legged leaf support.
- ✓ Rounded corners to keep projects safe from snags and from either yourself or children catching themselves accidentally.
- ✓ Available in 3 finishes, Beech Teak & White.
- ✓ Fitted with 8 large, lockable easy rolling castors. Making it no problem to move from room to room.

Cupboards both sides!



...one side fitted with an adjustable shelf for larger items...



...the other fitted with removable storage baskets.

Precision cutting to the tip!



Possibly the best scissors you'll ever get to use!

Ask us about our new range of precision made German scissors..... a perfect companion for your new table.

Extra stable double leg design



£599
Ideal for any use!

**87cm/
34¼ins**

The correct height to stand and work at

Can't get to see the one you'd like?
Come see our range at an exhibition.
Visit us at www.hornfurniture.co.uk/events/ to find out where we are next.....

Horn
Crafting... Quilting... Sewing Furniture
www.hornfurniture.co.uk

(Please note: The sewing machine and accessories are not included)

The Horn *Maxi* Hobby Table

*Need space to create?
Whether you're a Sewer or Quilter...
We've got it covered!*

Have a look at our full range online now...
...or contact us for a brochure

AUTUMN 2016

Sewing with STYLE

- AVON Direct Sewing Machines, Bristol – 0117 977 8216
- BEDFORDSHIRE Tudor Rose Patchwork, Oakley, Bedford – 01234 824 983
- BERKSHIRE Sew Devine, Reading – 0118 926 8664
- BUCKINGHAMSHIRE Alans Sewing Machines, High Wycombe – 01494 527600
Threads and Patches, Milton Keynes – 01908 649687
- CAMBRIDGESHIRE Sew Creative Ltd, Cambridge – 01223 350 691
- CHEESHIRE All Fabrics, Stalybridge – 0161 478 8236/01706 624 651
Jaycotts, Chester – 01244 394 099
J & P Sewing Machines, Warrington – 01925 633 831
Phil Morton Sewing Machines, Macclesfield – 01625 433 131
- CORNWALL The Sewing Studio, Redruth -01209 216 942
- DERBYSHIRE Elegance, Derby – 01332 382 292
Ilkeston Sewing & Janome Centre, Ilkeston – 01159 307 664
- DEVON Exeter Sewing Machine Company, Exeter – 01392 275 660
Hulu, Modbury – 01548 831 911
Soft Touch Needlecrafts, Tavistock – 01822 617 673
- DORSET Hansons Fabrics, Sturminster Newton – 01258 472 698
Paulines Patchwork Ltd, Dorchester – 01305 261 022
So N Sews, Weymouth – 01305 766 411
- DURHAM UK Sewing Machines, Darlington – 01325 463 630
- ESSEX Home of Sewing by Regent, Ilford – 0208 478 0669
Superstitch Machine Co, Leigh on Sea – 01702 478830
- GLOUCESTERSHIRE Cotswold Sewing Machines, Stroud – 01453 763660
West End Sewing Centre, Cheltenham – 01242 244025
- HAMPSHIRE Eastleigh Sewing Centre, Eastleigh – 02380 650 808
Hampshire Sewing Machines, Fareham – 01329 280499
Reads of Winchester, Winchester – 01962 850 950
- HEREFORDSHIRE Badder Fabrics, Hereford – 01432 379 137
Parrs Sewing Machines, Hereford – 01432 353 951
- HERTFORDSHIRE British Sewing Centre, Borehamwood – 0800 888 661
Chicks Embroidery, Letchworth – 01462 670 007
Hobbysew, Hemel Hempstead – 0800 077 6711
Rebecca Woollard Sewing School, Hatfield Heath – 07887 654 717
Rona Sewing Machines, Waltham Cross – 01992 640250
Sewfine Sewing Machines, Watford – 01923 693 734
- KENT Ashford Sewing Centre, Ashford – 01233 620948
Barcham Sewing Centre, Whitstable – 01227 264 271
Maidstone Sewing Centre, Maidstone – 01622 670 254
The Sewing Shop, Canterbury – 01227 457 723
The World of Sewing, Pratts Bottom – 01689 638 638
The World of Sewing, Tunbridge Wells – 01892 533188
- LANCASHIRE ETTY-LILLY, Bolton-Le-Sands, Carnforth – 01524 734 713
Hobkirk Sewing Machines, Blackburn – 01254 693555
Hobkirk Sewing Machines, Bury – 0161 764 4450
Lestan Sewing Machines, Nelson – 01282 614 511
M & S Sewing Machines, Heywood – 01706 624 651/01706 366 943
Sew-Knit (Dalby & Jones Ltd), Preston – 01772 254 558
- LEICESTERSHIRE Cresswell Sewing Machines, Leicester – 07979 798 010
The Sewing Café, Hinkley – 01455 698 034
- LINCOLNSHIRE Couling Sewing Machines, Lincoln – 01522 521841
Seweezy, Gainsborough – 01427 614 570
- LONDON (GTR) Lewisham & Deptford Sewing Machines, Deptford – 020 8692 1077
Redgewell Sewing Machines, South West London, 020 8337 3444
Sewing & Craft Superstore, London – 020 8767 0036
SM Sewing Machines Ltd, London – 07850 310 518
The Sewing Centre, Battersea – 020 7228 3022
Wimbledon Sewing Machine Co Ltd, London – 020 8767 4724
- MANCHESTER (GTR) Bamber Sewing Machines, Manchester – 0161 707 7786
R. Bullock & Son Ltd, Wigan – 01942 247 836
- MERSEYSIDE Affordable Sewing, Moreton, Wirral – 0151 677 7755
Sewing & Knitting Centre, Southport – 01704 534 688
- NORFOLK Sew Creative, Norwich – 01603 305 888
Sewing Machine World, Kings Lynn – 01553 773362
- NORTHAMPTONSHIRE Sew Northampton, Northampton – 01604 637200
- NOTTINGHAMSHIRE Cresswell Sewing Machines, Nottingham – 0115 926 7572
- OXFORDSHIRE Witney Sewing Machine Centre, Witney – 01993 704535
Witney Sew & Knit Centre, Witney – 01993 702 772
- SHROPSHIRE Sewing Machine Centre, Shrewsbury – 01743 343 902
- SOMERSET Bredons Sewing Machines, Taunton – 01823 272 450
Monkton Elm Garden Centre Ltd, Taunton – 01823 412 381
- SURREY C & A Supply Co. Ltd, Cranleigh – 01483 267 777
Redgewell Sewing Machines, Worcester Park – 0208 337 3444
- SUSSEX Brighton Sewing Centre, Brighton – 01273 621 653
Clothkits Ltd, Chichester – 01243 533 180
Eclectic Maker, Worthing – 01903 681000
Hastings Sewing Centre, Hastings – 01424 423 108
- TYNE & WEAR G Tully Sewing Machines, Sunderland – 0191 565 7995
Sewing Machine Sales, Whitley Bay – 0191 252 5825
- WARWICKSHIRE Coventry Sewing Centre, Coventry – 02476 257266
Harry and Floss, Alcester – 01789 400 747
Leamington Spa Sewing Machines, Leamington Spa – 01926 338 749
- WILTSHIRE Cotswold Stitchcraft, Malmesbury – 01666 823 245
West Wilts Sewing Machine Co, Trowbridge – 01225 753 792
- WEST MIDLANDS Brewers Sewing Machines, Wolverhampton – 01902 458 885
D C Nutt Sewing Machines, Walsall – 01922 497 603
Frank Nutt, Kings Heath – 0121 444 3978
L & M Nutt, Sutton Coldfield – 0121 373 5497
S Nutt Sewing Machines, Birmingham – 0121 327 2828



MODEL 216-S

- 14 Stitches
- Auto 4-step buttonhole
- Variable stitch length
- Convertible free arm
- Quick change snap on feet

- WORCESTERSHIRE Creative Hands 2, Worcester – 01905 24940
Inkberrow Design Centre, Redditch – 01527 69100
Topstitchers, Kidderminster – 01562 822 698
- YORKSHIRE Arcade Sewing Machines, Huddersfield – 01484 429 808
C & G Sewing Machines, Bradford – 01274 306352
Electra (DA) Company, Doncaster – 01302 340 369
Flynn's® Browns of York, York – 01904 561234/611166
Knit & Stitch, Doncaster – 01302 366 022
Knit & Stitch, Rotherham – 01709 817 944
Lennox Sewing Machines, Rotherham – 01709 377 797
MKC Services, Leeds – 0113 245 3156
Sewing Centre, Scarborough – 01723 363 167
White Rose Sewing Machines, Harrogate – 01423 503767
Woodseats Sewing Machines, Sheffield – 0114 255 2822
- ISLE OF MAN Joan's Wools & Crafts, Onchan – 01624 626 009
- IRELAND Sew N Knit Belfast, Belfast – 0289 045 6015
Sew N Knit Lisburn, Lisburn – 0289 267 0908
Singer Sewing Centre, Ballymena – 0282 564 0034
- SCOTLAND David Drummond, Edinburgh – 0131 539 7766
ESC Sewing Machines, Keith – 01542 887 000
N.J. Sewing Machine Services, Brightons Falkirk – 01324 711 333
Pemberton's Sewing Machines, Stirling – 01786 462 993
Quilt Creations, Inverness – 01463 719 369
Sew Materialistic, Ayr – 01292 285 801
The Stitchery, Glasgow – 0141 237 9690
- WALES Calico Kate, Lampeter – 01570 422 866
Clifford's Sewing Machines Ltd, Swansea – 01792 655 928
J & B Sewing Machine Co Ltd, Cardiff – 01633 281 555
J & B Sewing Machine Co, Ltd, Newport – 01633 284 646
Quay Street Sewing Centre, Haverfordwest – 01437 762 355
Sewing Machines Direct, Wrexham – 01978 851 235

The 'Sewing with Style' offers are available from Janome sewing machine retail outlets nationwide. Promotion starts 3rd September 2016 to 24th December 2016. (All offers subject to stock availability.)

The **JANOME**

SEWING MACHINE HANDBOOK



- ✓ Best models for all skill levels
- ✓ Machine feet demystified
- ✓ Learn how an overlocker works



TIPS AND TRICKS

To get the best from your machine

EXPERT REVIEWS

By top industry
insiders



STRETCH YOUR SKILLS

With courses, kits and more

THE atelier SERIES



These contemporary styled, well illuminated, free-arm sewing machines with easy to use computerised features are perfect to take your sewing to a new level. The larger arm space and superior feeding system ensure they are equally suited to both larger projects and precision sewing.

DESIGNED FOR EVERY TYPE OF SEWING



atelier 3

A clear LCD screen helps you select from the 120 stitches including 7 auto 1-step buttonholes and alphabet.



atelier 5

This machine has an incredible 91 needle positions and an easy change needle plate to enhance straight stitch performance at up to 1,000 spm.



atelier 7

Quilters and designers will enjoy the AcuFeed Flex layered fabric feeding system and the automatic presser foot lift for easy pivoting.

For further information:

Telephone 0161 666 6011 or visit www.janome.co.uk

The World's leading sewing machine manufacturer



SMART ELEGANT SOPHISTICATED



JANOME



Welcome

to your Ultimate Guide to Janome sewing machines

In this 36-page booklet, we've crammed lots of inspiring and affordable machines, accessories and courses so you can find your perfect purchase.



Whether you're a beginner looking to develop your skills, fancy an upgrade or are looking for a machine with specialist features, we've rounded up our top choices in this guide. You'll be able to sew homewares, projects for children and fabulous garments, safe in the knowledge that you've chosen a reliable quality machine.

Feeling unsure about which model is right for you? Take a look at our handy guide on page 27 which will help you hone in on what you need from your machine, things to remember, what an overlocker is and whether you should invest in one. Don't forget, you can splurge on a new machine foot and open up a range of new stitches to incorporate in your sewing.

You'll also learn more about Janome's interesting history and hear why so many sewing celebrities recommend Janome. Plus we have a fabulous round up of the courses available at the Janome School Of Sewing near Manchester that will help you push your skills and introduce you to exciting new techniques.

We're so pleased you've picked up this guide and hope you find plenty of inspiration and advice inside.

Happy shopping!

Amy

Love Sewing Editor

In association with **JANOME**

Inside this Guide

Sit back and enjoy this sewing machine guide from Janome, where you'll find your perfect machine match, learn about the exciting courses Janome offers and you can keep your eyes peeled for fabulous historic adverts that ran years ago



18



30



12

3 WELCOME

6 HISTORY OF THE COMPANY

10 WHY JANOME?

12 MACHINES FOR BEGINNERS

14 MASTER YOUR MACHINE

16 MACHINES FOR INTERMEDIATES

18 MACHINES FOR
ADVANCED SEWISTS

21 EMBROIDERY MACHINES

22 OVERLOCKERS AND
COVERSTITCH MACHINES

25 TOP PICKS FOR FEET
AND ACCESSORIES

27 OUR GUIDE TO BUYING
A MACHINE

30 JANOME SEWING SCHOOL

34 SPOTLIGHT ON THE MEMORY
CRAFT 9400 QCP



Editorial

Editor Amy Thomas
Deputy Editor Bethany Armitage
Editorial Assistant Felix McNulty
Senior Sub-Editor Justine Moran
Sub-Editor Kayleigh Hooton
Senior Art Editor Denise Johnson
Designers Suzanne Guest

Publishing & Advertising

Head of Business Development

Ruth Walker

Advertising Sales Executive

Noune Sarkissian

noune.sarkissian@practical

publishing.co.uk

Advertising Consultant

Jane Bates

Subscriptions Manager

Daniel Tutton

Managing Art Editor Jennifer Lamb

Group Managing Editor Lee Campbell

Head of Content & Positioning Gavin Burrell

Head of Product Development Carol Jones

Group Buying Manager Olivia Foster

Buying Assistant Rachael Edmunds

Production Assistant Anna Olejarz

Ecommerce & Distribution Director Dave Cusick

Managing Director Danny Bowler

Group Managing Director

Robin Wilkinson

Distribution

Newtrade COMAG Magazine Distribution

jane.bates@practicalpublishing.co.uk

Tel 0844 826 0613

Contact

Practical Publishing International Ltd,

Suite G2 St Christopher House,

217 Wellington Road South,

Stockport SK2 6NG

info@practicalpublishing.co.uk

www.practicalpublishing.co.uk

Tel: 0844 561 1202

Fax: 0161 474 6961

Subscription Enquiries

Tel: 01858 438899

Love Sewing is published by Practical Publishing International Ltd ISSN 2054-832X



All material © Practical Publishing International Ltd. The style and mark of Love Sewing is used under licence from Craft Media Ltd. No material in whole or in part may be reproduced, stored or transmitted in any form whatsoever without the prior written consent of Practical Publishing International Ltd. The publisher welcomes contributions from readers. All such contributions and submissions to the magazine are sent to and accepted by the publisher on the basis of a non-exclusive transferable worldwide licence unless otherwise agreed in writing prior to first publication. Such submissions are also subject to being used, reproduced, modified, published, edited, translated, distributed and displayed in any media or medium, or any form, format or forum now known or hereafter developed, for any purpose, in perpetuity.

Stock images provided by Shutterstock, Inc

Produced in association with

JANOME

Janome Centre
Southside,
Bredbury Ind Est,
Stockport SK6 2SP
0161 666 6011

www.janome.co.uk



DO NOT FAIL TO EXAMINE
THE

NEW HOME

Sewing Machine

AND DO NOT PURCHASE ANY
OTHER UNTIL YOU DO. IT
IS THE HANDSOMEST, MOST
DURABLE, AND WILL DO THE
WIDEST RANGE OF WORK OF
ANY. A TRIAL WILL CON-
VINCE YOU.

Buy the NEW HOME and you
get the

→ BEST SEWING MACHINE ←

in the market.

THE NEW HOME SEWING MACHINE CO., ORANGE, MASS.

28 UNION SQUARE, N. Y.

CHICAGO, ILL.

ST. LOUIS, MO.

DALLAS, TEX.

BOSTON, MASS.

ATLANTA, GA.

SAN FRANCISCO, CAL.

FOR SALE BY

SPECIAL NOTICE.

A discount of 5% in the £ is allowed off
list price for prompt cash.

ALL MACHINES SENT CARRIAGE PAID

SOLE REPRESENTATIVES,
WRIGHT, TILLEY & Co.,
HIGH STREET,
MARLBOROUGH, WILTS.

NEW HOME SEWING MACHINES was the original trading name of JANOME SEWING MACHINES

A brief history of JANOME

Janome operates in over 200 retail outlets throughout the UK, and manufactures own-brand sewing machines for other large retailers. Find out more about its historic beginnings

The company we know today was actually developed over 150 years ago through the amalgamation of several machine companies. In this article we're looking back to the 1800s to learn more about the story of New Home and how Janome came to be the leading retailer for quality sewing machines.

The founding of New Home

In 1860, William Barker and Andrew J. Clark began producing the New England Single Thread Hand Sewing Machine in Orange, Massachusetts. Over the next 20 years, the New England machine and the Home Shuttle were its two most significant products. In 1882, the company reformed under the name New Home (a combination of the labels New England and Home Shuttle), and it continued to operate under that name for the better part of a century.

The Home Shuttle is one of the most widely sought-after collectors' models. In 1868 the patent for the Home Shuttle was witnessed by A J Clark of Johnson Clark who became New



View of the main office building for the New Home Sewing Machine Company located on South Main St, Massachusetts in 1990

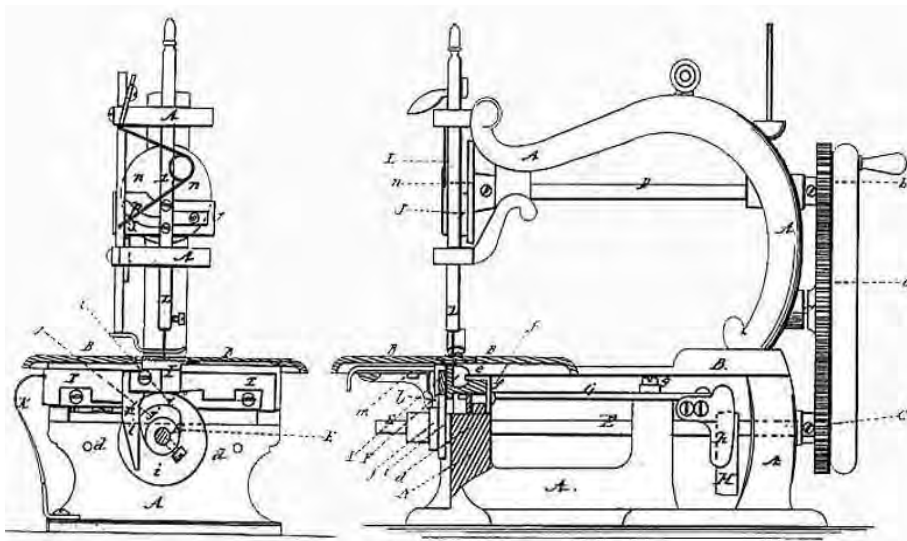

Stephen French's 1868 patent for Johnson Clark

Home's President, and John W Wheeler, who was to become the Treasurer and Secretary of New Home. Each machine was supplied with a shuttle, three extra bobbins, a hemmer and feller, braider, screwdriver, five needles, gauge, directions (English, German, French or Spanish) and a clamp.

In 1927 the New Home Company merged with The Free Sewing Machine Company and in 1953 merged again with the National Sewing Machine Company. Its motto was 'light running like a greyhound', which was represented by the use of the breed of dog on their advertisements and logo.

By 1960, 93 years after Barker and Clark first collaborated, New Home and the New Home brands were purchased by the Janome Sewing Machine Company of Tokyo, Japan.

Janome begins

In Japanese, the word Janome (pronounced Ja-NO-me) means 'eye of the snake'. The company earned the name in the 1920s when founder Yosaku Ose, a pioneer in Japanese sewing manufacturing, began to use a round metal bobbin system instead of the traditional long shuttle. The Japanese thought the new round bobbin looked like a snake's eye, and from the innovative design, a name for the company was born.

Janome has been leading the industry with such innovation ever since and expanded into over 100 countries around the world. As well as the headquarters in Hachioji, Japan there are sewing divisions in the United States, Canada, Mexico, Europe, Australia and New Zealand as well as agents in Africa, Central and South America and throughout the Pacific Rim of Asia. The company's manufacturing prowess has also made it a world-leader in the production of high-precision robots.

In 1979, Janome technology introduced the world's first programmable, computer sewing machine – the MEMORY 7. Today, Janome's Memory Craft computer models consistently stand out in the industry for their ease of use and precise stitch results. Take a look at the Horizon Memory Craft 15000 and the newest embroidery software products for an example of this.

For a more in-depth article on the early history of the company, visit The International Sewing Machine Collectors' Society and access the piece called The Men Behind New Home at www.ismacs.net/newhome or visit the comprehensive website www.sewalot.com, featuring articles and stories from collectors and enthusiasts.

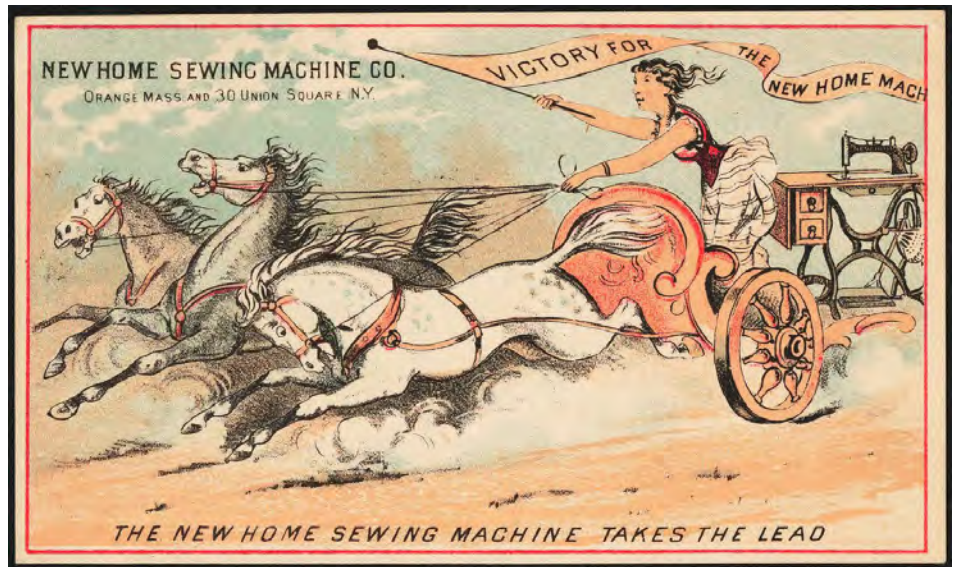

8x13cm sewing machine trade card, circa 1870-1900



8x13cm sewing machine trade card, circa 1870-1900



Historic adverts kindly provided by Janome

“In every home there’s a certain amount of work that is hard and disagreeable to do... but when it comes to doing sewing for the home, it can be turned into a genuine pleasure if you possess a New Home sewing machine. So simple a child can operate it”

THE LIGHT RUNNING

NEW HOME

SEWING * MACHINE

List price..... \$9 10 0
Cash "..... \$8 15 4

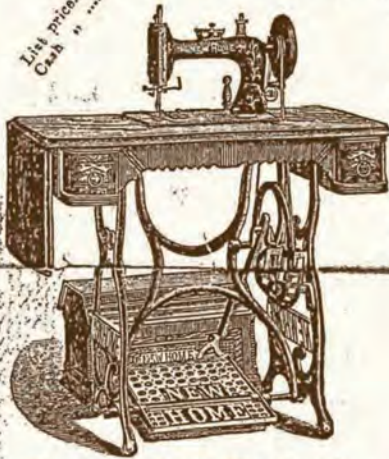

No. 14. Fancy Woodwork.

IN selecting a Sewing Machine you are apt to rely too much on what agents say, and do not take into consideration that it is for their interest to recommend the machine they handle, or the one they can make the most profit on. It is your duty to use your own judgment. We place the "New Home" on its merits, and ask your careful examination before you buy any other.



No. 16. Fancy Woodwork.

DROP CABINET No. 9.



Price on application.

ITS APPEARANCE WHEN CLOSED.

It is entirely automatic; comes to its place and is firmly locked ready to sew as soon as

• SIMPLEST •

• THE BEST •

No. 9. Drop Cabinet.

(PATENTED.)

Price on application.



PARTIALLY OPEN.

ANY one who examines the NEW HOME carefully must admit that it possesses SUPERIOR Qualities. We would call especial attention to the NEW STAND, which speaks for itself, and certainly must gain New Laurels for the NEW HOME. This with its new woodwork will convince the most prejudiced that for beauty of design and elegance in finish the NEW HOME takes the lead.



No. 15. Fancy Woodwork.

THE WOODWORK NOW PLACED UPON THE NEW HOME IS FAR SUPERIOR TO ALL OTHERS

Owing to the great popularity of the NEW HOME, it can now be found in all the principal cities and towns in the United States, and agencies have been established in all parts of the world. The factory is located at Orange, Mass., and is one of the oldest and largest. The NEW HOME is of the very highest grade and adapted to all varieties of work. Thousands who are now using the NEW HOME are satisfied they have the BEST. Try the NEW HOME and if you find it is not the best, do not buy it. If no agent is near you write direct to THE NEW HOME SEWING MACHINE CO., Orange, Mass.

What can I say about my JANOME MACHINE?!

We've asked some popular faces from the sewing world why they love their Janome sewing and quilting machines, coverstitch and overlockers. Let's find out what they had to say...



"I use a Janome Quilter's Companion 6260 - it's a great little workhorse, and has a fantastic selection of stitches with everything you could need for dressmaking."

Charlotte Newland, winner of The Great British Sewing Bee series 4

"Janome machines are great for my students; they're solid, reliable and easy to use. For anyone looking to get into dressmaking and not wanting to break their budget with their first sewing machine, Janome make the best entry level machines. Guaranteed to keep you sewing!"

Wendy Ward, pattern designer, sewing book author and owner of the MIY Workshop in Brighton



"Our Janome CXL 301 machines are such a great machine for all levels. The speed option makes learning to sew on these machines much easier and the variety of stitch options and variations like needle position, mean they are great for the advanced students. They really are a great all-rounder."

Lisa Comfort, pattern designer, sewing book author and owner of the Sew Over It sewing cafes



love Sewing

"When the time came to upgrade my machine I know I made the right decision with my new Janome. The quality is fabulous, plus the one-step buttonhole makes projects so much easy and I love the range of feet and stitches my machine offers."

Amy Thomas, Editor of Love Sewing magazine



"I love Janome machines – my favourite model is the DKS100, which we use in the Tilly and the Buttons studio. It's a great-quality digital machine with strong guts, an easy-to-use keypad, cheery turquoise face, plus lots of thoughtful touches – for example, it always stops stitching with the needle down so you don't lose your place. Hooray!"

Tilly Walnes, director of Tilly and The Buttons

"I bought my first Janome seven years ago when I launched my sewing school and fell in love with it! Since then I've bought over nine Janome machines, because they offer great value at every price point combined with innovative sewing machine technology."

Claire-Louise Hardie, The Thrifty Stitcher



sewing
made simple



"Since I started sewing and teaching, it's always been on Janome machines. I've always found them reliable, sturdy and very intuitive, meaning you can spend more time sewing and less time trying work out how to use your machine! I know my previous students would say the same!"

Sam Sterken, Editor of Sewing Made Simple Magazine

"I first learnt to sew on a Janome - it had a tortoise and hare speed on it and that tortoise was my best friend. I have recently used the Horizon MC8200 QCP and it's an amazing machine - with my Coverpro 2000 CPX I wonder how I ever coped without it when sewing jersey."

Jade Earley, finalist on The Great British Sewing Bee series 4



Brilliant for BEGINNERS

Under
£300

Looking for your first ever machine or a small basic one that's easy to transport to workshops and on mini breaks? We have selected the best budget-friendly machines to get you sewing!



MODEL 525S

This popular and award-winning model, which has featured on *The Great British Sewing Bee*, comes with 24 built-in stitches and a range of handy time-saving features for your household sewing projects. A jam-proof drop-in bobbin system ensures trouble-free stitching, while the buttonhole foot measures the button to produce perfectly matched buttonholes in one easy step.

With
jam-proof
bobbin

Stitch width and length are adjustable and the drop feed facility is perfect for freehand embroidery, darning or specialist quilting techniques. The two-speed setting on the foot controls means you can slow the machine down while you're learning and speed it up once you've built up your confidence! Awards aren't won for nothing, and the 525S is definitely a steal.

Best for
the casual
sewist

MODEL 2200XT

This is a great all-round machine with a good selection of popular stitches and features. It is a really easy to use two-dial model, with one dial for stitch selection and the other for adjusting stitch length. It just couldn't be simpler.

The automatic one-step buttonhole produces perfect buttonholes in one motion and there's plenty of accessory storage within machine. It also comes with a soft cover for protection.



MODEL 423S

This metal-bodied machine comes with a fantastic range of features and 24 built-in stitches that can be viewed at a glance on the front panel. It is easy to use, with a dial for stitch selection, and slide controls to adjust stitch length and width to suit different fabric. It also comes with Janome's fabulous one-step buttonhole and automatic needle threader.

Sturdy
and robust
machine

You can sew in reverse easily by pushing down a lever that locks thread ends in place, and there's a drop-feed lever for freehand embroidery. The 423S is a wonderfully robust machine capable of handling bulkier projects, and is great value for money for the experienced sewist tackling a range of different projects.



MODEL
J3-18

This practical little machine comes with a good range of 18 stitches, including utility stitches for general sewing projects, eight stretch stitches, and two decorative stitches for something a little special. The J3-18's automatic needle threader makes setting up a breeze, perfect for newcomers to sewing, and this machine also comes with a drop-feed facility for freehand embroidery, a reverse stitch lever, and a one-hand thread cutter. Super handy!

The J3-18 is a two-dial model, with one dial for stitch selection and one for stitch length adjustment. It's portable and lightweight, so you can take it with you to workshops and classes while building your confidence, and this machine converts easily to free arm with the removal of its detachable storage box.

Best
entry-level
machine



MODEL
J3-20

A step up from its little brother the J3-18, this model features 20 built-in stitch choices – 16 utility stitches to suit a range of projects, including satin and stretch stitches, and four decorative stitches. Like the J3-18, it can be converted into a free arm for circular sewing, and has a front-loading bobbin system.

Features a
one-step
buttonhole

This machine's lightweight design and time-saving features, as well as the fact that its extra high foot lifter means it is capable of sewing multiple thicknesses, make it perfectly suited to sewists who love projects for the home.

MODEL
J3-24

This machine is top of the J3 series, with a total of 24 stitches including 12 stretch stitches and eight decorative stitches. It comes with all of the features and accessories you will find with the J3-18 and J3-20. This three-dial machine has fully adjustable length and width settings, making it quick and easy to set up for appliqué sewing as well as tackling more general projects.

This is a great machine for a dabble in quilting or projects that require the use of heavy fabric, as the extra height foot lifter increases the height of the foot and allows for extra bulk.

Best for
all-round
projects



Master YOUR MACHINE

Each machine model offers a range of features and functions, but all have these fundamental elements in common. Use this handy guide and you'll know your way around yours in no time

1. THREAD GUIDES

Two threads make up each stitch. The top thread from the spool passes through these guides to regulate the tension of the thread before feeding it through the needle. The second thread comes from the bobbin.

2. REVERSE FUNCTION

Use to set the machine working in a reverse direction, to move backwards across a stitched line. This function is used when securing the threads at the start and end of a line of stitching.

3. NEEDLE & NEEDLE CLAMP

The needle is removable to allow you to select from a variety of types and sizes to suit your project. The needle is held in place by the clamp. Most machines include a tool for tightening and loosening the clamp to access the needle.

4. PRESSER FOOT

Holds the fabric in place as you work. Can be removed and replaced with the type required for a specific sewing task, ie zips.

5. BOBBIN CASE

Inside the clear, removable cover is the bobbin case, which houses the bobbin. The bobbin is wound with thread and provides the second thread for each stitch.

6. FEED DOGS AND NEEDLE PLATE

On the plate are guide markings to assist straight sewing and measuring seam allowances. Moving parts lie underneath the needle plate with spiked teeth that protrude from the opening to help to move the fabric through the machine.



7. TENSION CONTROL

This dial regulates the tension of the stitches by determining the speed at which the thread passes through the machine. Messy stitches, or loops of thread or knots on the right or wrong side of the fabric are a common sign that the tension needs to be reset.

8. BOBBIN WINDER

Winds thread from the spool onto the bobbin. Ensure that the thread is fed evenly onto the bobbin to maintain the correct tension. Place an empty bobbin to wind thread onto the bobbin.

9. SPOOL HOLDER

This pin runs through the centre of the thread spool, allowing it to feed smoothly through the machine.

10. HAND WHEEL

Manually operates the mechanics of the machine, moving the needle up and down to engage the feed dogs and move the fabric.

11. STITCH SELECTOR

Allows you to select from the different stitches on the machine and includes a menu from which you make your selection. The stitch is selected by moving the wheel to the correct symbol.

12 + 13. STITCH LENGTH AND WIDTH SELECTORS

Increase or decrease the length or width of your stitch. The shorter the stitch, the more are worked across the line of sewing, making it stronger. The width applies to stitches where the needle moves left and right, ie zigzag. For decorative stitches, the wider the better.

14. FREE ARM

Remove to create a narrower working space, when sewing smaller items or inserting sleeves, or trouser hems.

15. ACCESSORY DRAWER

Use to store alternative presser feet, spare bobbins and maintenance tools.

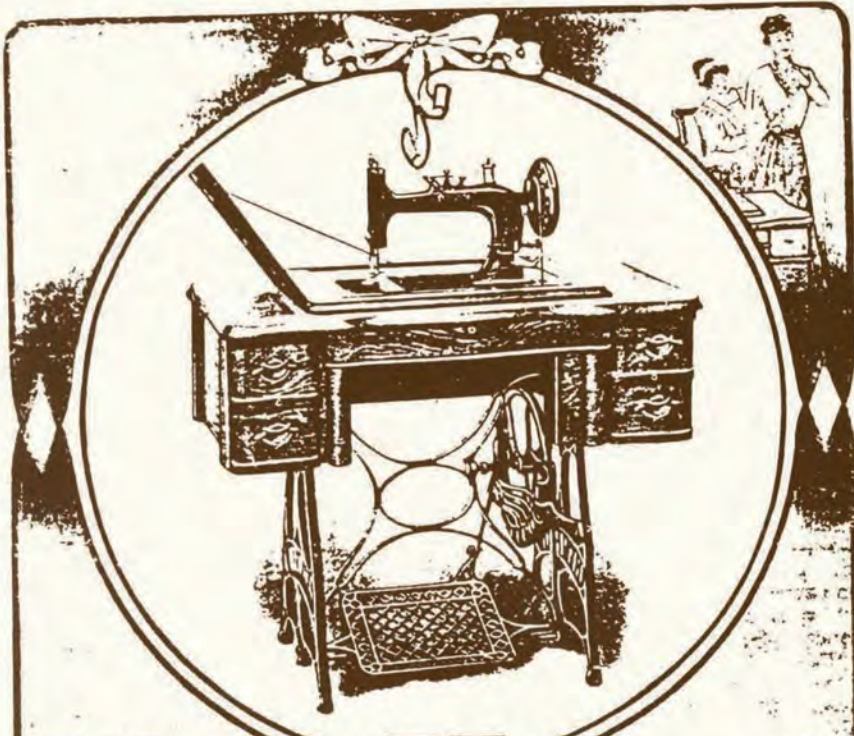

NEW HOME

IN every home there's a certain amount of work that is hard and disagreeable to do, and in which the housewife can find little enjoyment other than the general enjoyment of doing whatever may be necessary to the maintenance of the home. But when it comes to doing sewing for the home, it can be turned into a genuine pleasure if you possess a

NEW HOME Sewing Machine

So simple a child can operate it, and so light-running you never tire of it. Whatever kind of work you want to do, there's an attachment to do just that thing, and it's on and off in a moment.

If you are a home-maker, you can't afford to do without a New Home Machine. It's an efficient, willing helper, always ready, never weary. Will

MAY 3, 1906

THE YOUTH'S COMPANION.

Ever Stop to Think

how much you could save by doing your own sewing? The amount would surprise you in the course of a year!

The sewing in the average family is not difficult, and with a

NEW HOME SEWING MACHINE

it isn't a laborious task. On the contrary, using the machine is a genuine pleasure, and your garments will not have that cheap, factory-made appearance, characteristic of department store goods. Neither will their imperfections in finish reveal the carelessness of the hurried seamstress. From every point of view, it pays to own a New Home Sewing Machine. The only expense is the initial investment. After that there is profit in everything you do with it.

Look into it. Write a postal for our literature and mail it now while you think of it.

THE NEW HOME SEWING MACHINE CO.,
Orange, Mass.

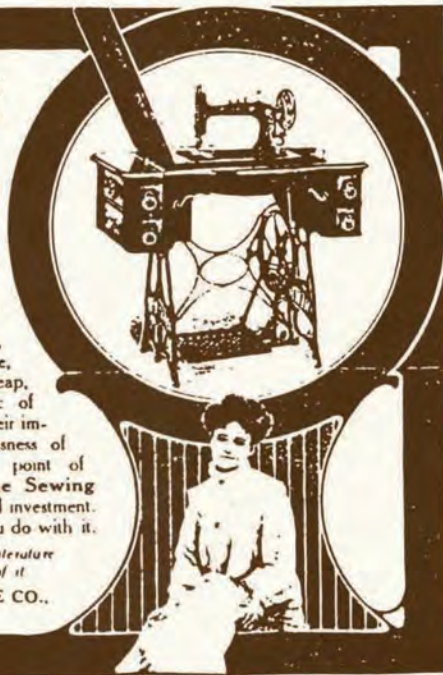

Before You Purchase Any Other Write
THE NEW HOME SEWING MACHINE COMPANY
ORANGE, MASS.

Many Sewing Machines are made to sell regardless of quality, but the "New Home" is made to wear. Our guaranty never runs out.

We make Sewing Machines to suit all conditions of the trade. The "New Home" stands at the head of all High-grade family sewing machines Sold by authorized dealers only.



THE moment you first open a New Home, your enjoyment of it begins, and it continues as long as you have occasion to use a sewing machine. The superiority of the New Home shows even in the lifting of the cover. Where other machines catch and work hard in opening, the New Home works easily and smoothly. In many machines the belt is liable to get tangled up in raising the head. In the New Home the head comes up with the belt always in place ready for business.

The New Home is the lightest running and makes the least noise of any machine on the market. In many other machines the working parts in the head and under the head are loosely and imperfectly fitted; this allows lost motion, makes the machine noisy, and increases the wear and tear. The working parts of the New Home are finished and fitted as precisely as the works of a watch. It is practically noiseless, and is the least liable to get out of order of any machine made.

You don't buy a sewing machine often. Get the New Home at the start, and avoid trouble and disappointment ever after. Send for the New Home literature and the name of a dealer.

The New Home Sewing Machine Co.,
Orange, Mass.

Inspiring intermediate MACHINES

Around
£500

If you're ready to take a new mid-range model home, we've rounded up our favourite machines that will give you plenty of bells and whistles to use in your sewing, but won't break the bank



Best for
fuss-free
sewing

MODEL HD2200

This simple and sleek machine combines power with elegance and simplicity, incorporating handy time-saving features without being overly complex to use. It is robust enough to handle bulkier projects and regular use, while its no-fuss design, with a top-loading jam-proof bobbin system, an easily accessible thread cutter to avoid tangles and a convertible free arm for circular sewing, means you can crack on without any faff.

Once you've selected your stitch, the built-in information window will advise on stitch width and length and the correct foot to use. The machine comes with plenty of accessories, including a handy hard cover for protection, and comes with 22 stitches for all your sewing needs.

MODEL CXL301

This machine is a great introduction to computerised sewing for those accustomed to mechanical models, and is also a steal in terms of price when you consider the fantastic features it shares with some top models. Just some of the CXL301's special features are a speed controller, a button that programmes your needle to finish either up or down, a lock stitch button and a stop/start button.

It's also designed for ease of use, with snap-on feet, and comes complete with a soft cover. Perfect for competent sewists building confidence and pushing themselves, we can guarantee the CXL301 won't be beaten on value for money.

Best for
newcomers to
computerised
sewing





MODEL
DKS30

Using a sewing machine could not possibly be simpler than it is with the colourful and fully computerised DKS30. DKS stands for Direct Key Selection, and each of the 30 built-in stitch keys has an LED light that is activated when selected, and stitch width and length are fully adjustable. The top-loading full rotary hook system is jam-proof and magnetic for ease of use, and the extra needle penetration power of the DKS30 means you can sew across heavier fabric and multiple layers with ease.

The DKS30's arm is detachable for free-arm sewing, and it also comes with a seven-piece feed mechanism, a drop-feed facility for free-motion quilting and much more.

Best for
time-saving
features

MODEL
DXL603

This fantastic all-rounder comes with no less than 60 built-in stitches, which can be selected and adjusted easily on its LCD information screen. This full-size machine is super lightweight at only 6kg, so is perfect for taking with you on the go. The maximum speed controller facilitates precision sewing, while other handy features will save you loads of time that you can use for even more projects.

Although it is designed for quilters, this model has plenty to offer dressmakers, including seven buttonholes, and is capable of handling fine fabric such as satin and sheers, as adjustable foot pressure means you can fine tune the feeding to suit your fabric.



Best for
quilters

Advanced and AMAZING

Over
£500

After you've been sewing a while you may want to upgrade to a machine that can match your expanding skills. Here are our top picks for high-end machines with the latest desirable features



MODEL DKS100

Top of the DKS range, this fully computerised machine comes with 10 large buttons to select from the most popular stitches, plus four more for the automatic buttonholes, while other stitches from the 100 options that come built-in with this model can be selected with the use of the large numeric keypad. Stitch width and length adjustment keys are located directly under the screen, and there's even a special key that enables some stitches to be elongated by up to five times!

Best
for ease
of use

The DKS100 is stylish as well as practical – the high-gloss azure fascia complements the ceramic-feel buttons perfectly, and would make a stunning fixture in any sewing room.

MODEL TXL607

This machine, which is the top model in Janome's XL series, will not be beaten on stitch selection, with more than 400 stitch options built in, including alphabets and numbers for superb versatility. The memory function means that your machine can memorise combinations of letters, numbers and even stitches, so the possibilities are truly infinite!

You'll also find the other mod cons that make computerised sewing a breeze – a maximum speed controller, needle up/down facility, auto lock-stitch and LCD information screen. The TXL607's superior feeding system is extra special, making for fantastic fabric handling. Considering the range of creative options built in, the TXL607 is also well priced in comparison to competing machines.

Best
for the
creative
sewist



Best for
precision
sewing



ATELIER 3

The original in the high-tech Atelier series, the Atelier 3 is designed for all types of sewing and comes with many fabulous features built in. Fully computerised, it comes with 120 built-in stitches, one-step buttonholes in seven styles, and can memorise stitch and alphabet combinations.

A generous arm space and longer bed size make this a good machine to use for bigger projects, but its 71 needle positions mean it is equally suited to precision sewing, and such versatility means it's not hard to see why this model is so popular. Optional add ons mean that the Atelier 3's potential is not restricted to its built-in features, so the sky's the limit!

ATELIER 5

The second model in the Atelier series steps up its game with 170 built-in stitches, buttonholes in 10 styles, and much more. Like the top-of-the-range Atelier 7, this machine is compatible with three optional kits for quilting, home furnishings and fashion sewing. A total of 91 needle positions makes the 5 a fantastic choice for precision, and up to 9mm of stitch width gives you a wealth of creative options for your makes.

An auto thread tension setting helps to prevent tension problems when sewing materials with different thicknesses, and the sewing bed is generous and well lit. A solid choice for the prolific home sewist.

Best for diverse projects



ATELIER 7

This latest fully computerised model in the Atelier series has been designed to meet every sewing challenge you could imagine. Three optional kits are available for the machine, as with the Atelier 5, one for quilting, one for home furnishing, and a third for fashion sewing to tailor your machine to the projects you sew the most.

With a staggering 240 built-in stitches, one-step buttonholes in 11 styles, a stitch width of up to 9mm, the ability to memorise stitching and alphabet combinations, and many more features than we could ever have room to list, the Atelier 7 may be towards the higher end of the price range, but you certainly get what you pay for.

Best for technology and mod cons



MODEL 1600PQC

With a speed of up to 1,600 stitches per minute, the semi-industrial PQC (Professional Quilting Machine) is perfect for larger scale, more ambitious projects requiring speed, substantial arm space, and a flawless straight stitch. The 1600PQC is solid and sturdy, weighing in at 11.5kg, but is remarkably quiet and smooth for a machine with such speed and power.

An automatic thread cutter cuts the top and bobbin threads at the push of a button, while up to 11lb of downforce mean your needle will be able to pierce even the bulkiest projects and a longer arm provides 50% more working space than a regular machine. The 1600PQC is streamlined, powerful and perfectly fit for purpose.

Best for speed and power



FOR YOUR NEAREST JANOME STOCKIST

EAST ANGLIA

Chicks PE Design

We stock and repair all Janome and Elna sewing machines. In store we have wool, sewing patterns, fabrics and haberdashery to complete your projects.

13 The Arcade Letchworth Garden City

Hertfordshire, SG6 3ET
www.chicksembroidery.co.uk
01462 670007

Rona Sewing Machines

Stockists of Janome machines from £99 to £6495, we offer sales & service to all models & free tuition. Also suppliers to education. Established for 42 years.

143a, High Street, Waltham Cross Herts, EN8 7AP
01992 640250
sales@ronasewingmachines.co.uk
www.onlinesewingmachines.co.uk

Sewing Machine World

Free machine demonstrations in our large showroom, over 30 models on display, the best warranty terms, free training on every new machine purchased, servicing and repairs with free estimates.

Unit 7, Laen Court, Horsley's Fields Industrial Estate Kings Lynn PE30 5DD
01553 773362
www.sewingmachineworldonline.co.uk

EAST MIDLANDS

Cresswell Sewing Machine Co

Sewing machine sales, service and parts. Repair service offered for most machines. Open 9.30 - 4pm Monday to Friday. 10am - 1pm Saturday

0115 926 7572
83 Mansfield Rd, Daybrook, Nottingham, Nottinghamshire, NG5 6BH

Seweezy

We are a family run business trading in Gainsborough for over 30 years. We service and repair most makes of domestic and industrial sewing machines.

63A Trinity Street, Gainsborough, Lincolnshire, DN21 1JF.
01427614570.
seweezy@hotmail.co.uk

The Sewing Cafe

A social sewing emporium, The Sewing Cafe brings you bright, modern fabrics and sewing workshops. Plus, Janome sewing machines to play on or pop in and hire by the hour.

116 Castle Street, Hinckley Leicestershire, LE10 1DD
www.thesewingcafe.co.uk
01455 698034
hello@thesewingcafe.co.uk
www.facebook.com/thesewingcafe

LONDON

Home of sewing by Regent

Your local choice for JANOME Sewing & Embroidery Machines, Overlockers & Coverstitchers. Sales & Repairs VAST FABRIC RANGE incl. Patchwork, Craft & all sewing supplies.

Tel. 0208 4780669
www.facebook.com/homeofsewing

Lewisham & Deptford Sewing Machines Ltd

EST over 50 years, Sewing Machine specialists, full workshop facilities with trained engineers on the premises. The south/east leading suppliers of every make, with branches in London & Kent.

www.sewingmachinesuk.co.uk
sales@sewingmachinesuk.co.uk
0208 692 1077
0208 692 0228

NORTH

Electra D A Company

Sales, service and repair centre Sewing machines to suit all budgets After sales support Specialist advice given Established over 45 years

155 St Sepulchre Gate West Doncaster, South Yorkshire DN1 3AW
01302 340369

MKC SERVICES

Knowledge and experience of all sewing machines. Repair and service on site (Home calls available) Best service at the most competitive price, tuition and advice, sewing clubs/workshops.

0113 245 3156
Unit 8, 30-38 Dock St, Leeds LS10 1JF
mkcservice.co.uk

White Rose Sewing Machine Company

We have been stockist of Janome machines for over 30 years, still a friendly family run business.

We service and repair all makes of sewing machines and we also stock haberdashery and Horn Cabinets.

3 Commercial St, Harrogate HG1 1UB
01423 503767
www.whiterosesewing.com
info@whiterosesewing.com

NORTH EAST

Tullys Sewing Machines

We are a family business providing high quality branded sewing, embroidery and over-locking machines and a friendly, professional and efficient service to customers for over 50 years.

www.tullyssewingmachines.co.uk
www.facebook.com/tullyssewing

machines

5 Holmeside, Sunderland, SR1 3JG
0191 5657995

NORTH WEST

Abakhan - Birkenhead

We run free sewing machine demonstrations - please come and try before you buy! NEW Overlocking demos coming soon. Great in-store offers.

8-12 Greenway Road Birkenhead, CH42 0NG
0151 652 5195
Open 7 Days

Abakhan - Bolton

We run free sewing machine demonstrations - please come and try before you buy! NEW Overlocking demos coming soon. Great in-store offers.

Unit 2B Burnden Park Manchester Rd, Bolton BL3 2NE
Open 7 Days

Abakhan - Chester

We run free sewing machine demonstrations - please come and try before you buy! NEW Overlocking demos coming soon. Great in-store offers.

65 Frodsham Street Chester City Centre, CH1 3JJ
01244323 640
Open 7 Days

Abakhan - Liverpool

We run free sewing machine demonstrations - please come and try before you buy! NEW Overlocking demos coming soon. One day Sewing Machine classes, £42.50 includes all materials and equipment.

Book Online www.abakhan.co.uk
Liverpool, L3 8LX
0151 207 4029
Open 7 Days

Abakhan - Manchester

We run free sewing machine demonstrations - please come and try before you buy! NEW Overlocking demos coming soon. Great in-store offers.

111 - 115 Oldham Street Manchester, M4 1LN
0161 839 3229
Open 7 Days

Abakhan - Preston

We run free sewing machine demonstrations - please come and try before you buy! NEW Overlocking demos coming soon. Great in-store offers.

Unit 3b Corporation Street Preston, PR1 2UQ
01772 202 677
Open 7 Days
Affordable Sewing Machines Ltd

Sewing machines and accessories. A range of haberdashery, yarn, patterns and spare parts available in store. We specialise in repair and service of machines, with free local pick-up and delivery.

185 Hoyake Road, Moreton, Wirral Merseyside, CH46 9QA

Hobkirk

We are a family run business with an extensive range of Sewing Machines available to buy online or in-store.

Check out our website www.hobkirk.co.uk or visit us
120-128 Darwen Street Blackburn BB2 2AJ.
01254 693 555
admin@hobkirk.co.uk

J&P Sewing machines

Established 1985. Stockists of leading brands of new and used sewing machines, overlockers, & embroidery machines. Sales, Service, & Free estimates!

01925 633831
2 Suez Street, Warrington, WA1 1EG
www.jpsewingmachines.com

Jaycotts

Wide range of Janome sewing machines, overlockers, coverstitch, accessories, presser feet etc Shop online and at our Chester store. Call now for our Free mail order catalogue!

01244 394099
jaycotts.co.uk
Jaycotts, Chester, CH1 4LT

Sew-Knit Machine Centres

We are long established Sewing Machine Experts (1957) priding ourselves in helping you to choose the correct machine and making certain you get the best from it.

87 Lancaster Road Preston, PR1 2QJ
01772 254558
07989 900389

Sewing & Knitting Centre

We've been selling Sewing Machines and accessories for over 25 years. We carry Janome, Pfaff, Singer and Bernina machines and Overlockers Selling a good range of threads, hand & machine & sewing accessories

67 London Street Southport Merseyside
01704 534688
sales@sewingmachine.co.uk
www.sewingmachine.co.uk
01516777755
www.affordablesewingmachines.biz

Embroidery and EMBELLISHMENT

Looking to stretch your creative skills further? Why not let the artist in you loose by embellishing your projects with incredible stitches? These machines may be an indulgence to some, but encouraging your sewing passion can lead to fantastic results.



Under
£1,500

Best for
professional-
quality
embroidery

MEMORY CRAFT 500E

Janome's Memory Craft range provides top-quality embroidery machines to suit a range of budgets, and the 500E is a solid model.

You can use the machine's USB port to transfer designs quickly and easily from your computer, and then navigate with the use of the built-in touch screen to select fonts, browse designs, and tailor each project to your requirements and create designs up to 200x280mm in size.

There's a top drop-in bobbin and built-in threading to save time and fuss. Once you're set up, you'll be able to create unique and gorgeous embellishments for your wardrobe, home and loved ones – the possibilities are truly infinite, so your imagination can run riot!

MODEL FM725

This specialised embellishment machine will bring out the artist in you – select from your palette of fabric and thread and blend them to create unique and beautiful textures and surfaces. A needle guard is built in for safety, and there's easy access to the lint collection area under the needle plate.

This smart machine doesn't require any thread – five barbed needles mesh the fibre to secure two or more pieces of fabric together, making it perfect for needle punch felting. There's a tutorial DVD included to get you up to scratch before you start, but the FM725 is so accessible and easy to use that we guarantee you'll be creating unique and gorgeous embellishments in no time!

Best for
creating
unique
designs



Around
£300



Around
£6,495

Best for
just about
everything

MEMORY CRAFT 15000 V2

is Janome's latest flagship model, now with 510 built-in stitches (previously 500) and a number of subtle changes to this very exclusive model. It incorporates all the best features for sewing, embroidery, quilting and craftwork and has the largest work area of any equivalent model available. The special edition model offers 13 automatic one-step buttonholes and 10 built-in fonts.

It is the first machine of its kind to have WiFi, the first to work with an iPad and the first to have its own Apps! Its built-in Acu-feed system ensures precise handling and the supplied knee-lifter controls variable zigzag stitching. Just one more thing... it also has the largest and fastest touch screen on the market. What more can we say!

Overlockers and coverstitch MACHINES

As your skills progress you may like to invest in a second machine to help your projects feel more polished. Choosing an overlocker, coverstitch or hybrid of the two can mean adding stretchy, resilient seams, professional hems and decorative finishes to your garments

MODEL 6234XL

The Janome 6234XL makes the overlocking process a breeze, with its differential feed system and handy rolled-hem conversion feature. This machine is robust and ready for the task with easy threading.

Don't be afraid to try two-thread overlocking too, using the sliding thread guide and you can easily adjust the cutting width to suit the thickness of the material. Perfect for heavyweight fabric.

Best for
easy
threading



Under
£450

Best
2-in-1
machine



Under
£950

MODEL 1200D

This top-quality model combines an overlocker with a coverstitch machine to meet a whole range of sewing needs. The 1200D comes with 13 different overlock stitches capable of handling up to five threads for a variety of fabric and projects. As a coverstitcher, it can handle two and three threads and comes with six popular cover hem stitches.

In short, this versatile machine has all you need to be producing fantastic garments in no time, and it's also a breeze to use – there's no need to change the needle plate or foot for a rolled hem, and the upper looper system is easily adjustable for cover or top cover hems. This is a machine guaranteed to take your sewing to the next level.

Best introductory machine



Around £269

MODEL 9300DX

This three- to four-thread overlocker is a compact and sturdy machine that sews like a dream and is surprisingly quiet. It comes pre-threaded and has a built-in rolled hem feature with no plate change required. The 9300DX's differential feed prevents puckering and stretching and can be used for a range of fun special effects, and the upper knife is retractable for decorative sewing.

Threading is super simple, with colour-coded guides and a quick-threading lower looper – all you have to do is lay the thread into the guide, and when you lift the presser foot for rethreading, the thread tensions are automatically released so that you can draw the thread through smoothly.

MODEL CoverPro 2000CPX

This long arm, heavy-duty coverstitch-only machine sews at high speed while looking and operating like a sewing machine. Its design wedges industrial capability with domestic convenience, so you'll find all of the functions you need for fast and simple sewing in familiar places.

The fabulous innovative features that will be less familiar (but that we guarantee will be very welcome) include Janome's unique Seam Tightening System (STS) and Tension Level Control (TLC) for use with fine fabric. The CoverPro's differential feed ratio is adjustable from 0.05-2.25mm, so there's scope for exceptional control and the creation of a whole host of special effects.

Best for a truly professional finish



Around £479

How overlockers work

A standard overlocker has two loopers and two needles through which the threads pass and form stitches to create and finish seams. An overlocker forms a sophisticated seam and joins layers of fabric together. A blade cuts a clean edge from the fabric, and two loopers and two needles carry threads that stitch the seam and cover the edges neatly. The two loopers sit below the fabric and wrap the cut edge with threads while the two needles pierce the fabric from above and produce the seam.

Most overlockers have two needles, and you can use one or both as needed. These are held in place with a screw in the same way as in a sewing machine. Use the left or both needles for a wide overlocked seam and the right one only for a narrow overlocked seam.

On an overlocker there are two sets of feed dogs; the front set pushes the fabric under the needle and the second set pulls it away from behind the needle. The differential feed controls how the feed dogs work. For stable fabric, the two sets work at the same rate to feed the fabric under the foot and needle. It can also be adjusted to feed stretch knit fabric evenly or to encourage a fabric to gather into tiny tucks or to stretch a fabric to form a wavy edge.



NEW THE SEWING MACHINE OF QUALITY.

NOT SOLD UNDER ANY OTHER NAME. **HOME**

WARRANTED FOR ALL TIME.

If you purchase the NEW HOME you will have a life asset at the price you pay, and will not have an endless chain of repairs.



Quality Considered it is the Cheapest in the end to buy.

If you want a sewing machine, write for our latest catalogue before you purchase. The New Home Sewing Machine Co., Orange, Mass.

NEW HOME



THE SEWING MACHINE OF KNOWN VALUE

Known the world over for its Serving Qualities.

The only Sewing Machine which is a life asset at the price you pay. Purchase the NEW HOME and you will not have an endless chain of repairs. It is better made, does nicer sewing, easier to operate, and more silent than any other. Guaranteed for all time. Write THE NEW HOME SEWING MACHINE CO., Orange, Mass. for booklet H

Supt
10/
1911

With the beginning of the New Year why not invest in a

New Home Sewing Machine

and institute a new order of things—learn to do your sewing easily, beautifully, perfectly. The NEW HOME will continue to do this as long as it lasts, and it will last a lifetime.

The Leader in every land where a Sewing Machine is used.

Send Us Your Name,

please, that we may send you our literature; it will interest you, whether you are ready to buy or not

New Home Sewing Machine Company,
Orange, Mass.



1917
NEWHOME



"I'll get it for my wife"

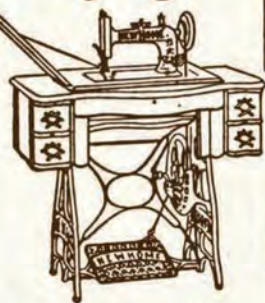

NO OTHER LIKE IT. NO OTHER AS GOOD.

Purchase the "NEW HOME" and you will have a life asset at the price you pay. The elimination of repair expense by superior workmanship and best quality of material insures life-long service at minimum cost. Insist on having the "NEW HOME".

WARRANTED FOR ALL TIME.

Known the world over for superior sewing qualities. Not sold under any other name.

THE NEW HOME SEWING MACHINE CO., ORANGE, MASS.

FOR SALE BY

J. F. HIGGINS & CO

Athol, Mass.

THE BEST IS THE CHEAPEST.

NO OTHER LIKE IT



RUNNING

NO OTHER AS GOOD

NEW HOME

BALL BEARING

SEWING MACHINE

MOST POPULAR

NOT SOLD UNDER ANY OTHER NAME.

OUR WARRANTY ON THIS MACHINE NEVER EXPIRES.

This machine is built upon honor, not on contract; it is made for lifelong service. Get a NEW HOME and the sewing machine question will be settled for life. Sold by authorized dealers only. All parts are inter-changeable. Write for our literature.

THE NEW HOME SEWING MACHINE CO., Orange, Mass. Dept. A.

51
"The Sewing Machine" magazine Oct. 1913

Best foot FORWARD

Make your sewing time more stress-free by investing in some amazing new machine feet that will help create a professional finish, allowing you to try new techniques

Blind stitch foot

Blind hemming can be a tricky business at times, which is why one of our favourite accessories is Janome's handy foot, designed specifically to take some of the stress out of it. The foot has a metal guide in its centre and three grooves on its underside, meaning that, while you're hemming, the fold of the fabric fits snugly against the guide to ensure accuracy, while the grooves prevent the fabric from slipping.

The needle swings over the metal guide, creating slack in the upper tension so that the pick of the stitch is almost invisible – a perfect blind hem every time with the hard work eliminated.

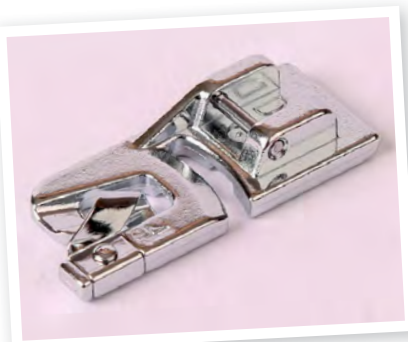

Hemmer foot (2mm)

Sometimes referred to as a rolled hem foot, this handy accessory is perfect for creating neat, narrow rolled hems every time. Narrow hems are often required for shirt tails, table linen and along the edge of ruffles, but the hemmer foot could prove to be a godsend for a whole variety of projects, providing a clean and professional finish.

Its design incorporates a scroll-shaped feeder and a straight groove along the underside to determine the width of the finished hem. 4mm and 6mm hemmer options are available for use with heavier fabric.

Concealed zipper foot

Invisible zips are a fantastic trick to any dressmaker's bow, and this clever foot means inserting them couldn't be easier. Sewing as closely as possible to the fastener is crucial in achieving success with invisible zippers, and this foot accomplishes that by slightly unrolling the zipper. Once it's been fitted, your zip will simply look like a part of the seam.

Janome's concealed zipper foot is suitable for sewing invisible zips into a range of fabric, from fine silk jersey to heavier wool and tweed, and is a must-have if you're looking to step up your sewing game.

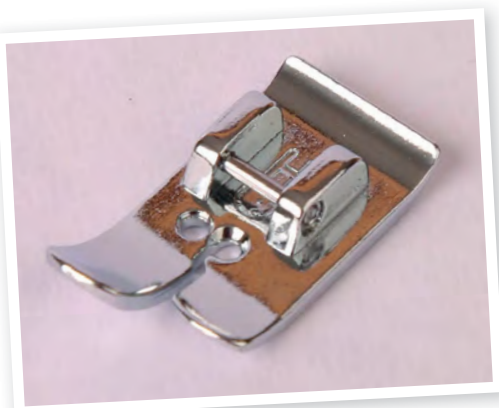

Straight stitch foot

A solid staple of any sewist's tool kit, the straight stitch foot is most often called upon for use with either very fine or very heavy fabric. A flat underside provides even pressure against your machine's feed dogs, facilitating a more accurate and consistent feed for a higher quality straight stitch.

At the same time, a rounded needle opening provides extra support around the needle to reduce the chance of any puckering or skipped stitches, and avoids the problems that can be encountered with a wide centre foot opening, which can cause the fabric to be pulled into the bobbin area. We all know how infuriating it is to have to unpick and restart fluffed stitches, so an accessory that can help avoid disasters in the first place is an absolute essential.



Bias binder foot

Janome's binder foot is used to apply pre-folded bias binding tape or bias tape that you've cut yourself to the edge of your fabric in one easy step. The foot itself is equipped with a small funnel to fold and guide the binding over the fabric edge before it reaches the needle, and it can be used with zigzag or decorative stitches as well as with a straight stitch, which means you can get creative when using it.

Janome's binding foot is best suited to use with 10-14mm binding tape.

Even feed foot with quilter's guide

Sometimes referred to as the walking foot, this accessory from Janome is designed with a set of feed dogs that allow fabric to feed without shifting and means you won't have to worry about an under layer of fabric coming up short. If you've ever had to unpick a topstitch because it's turned out irregular, then the even feed foot will be a dream for you too, as it stops your seam allowance from creating bulk, which can be a particularly frustrating problem when working collars and revers.

In short, this foot does what it says on the tin – you are guaranteed a perfectly neat and even stitch every time, which is worth the extra cost as it'll pay for itself in the time you'll save correcting mistakes.

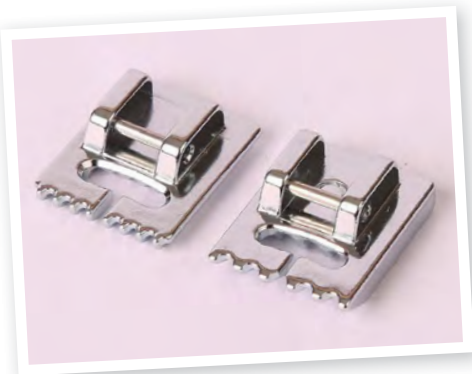
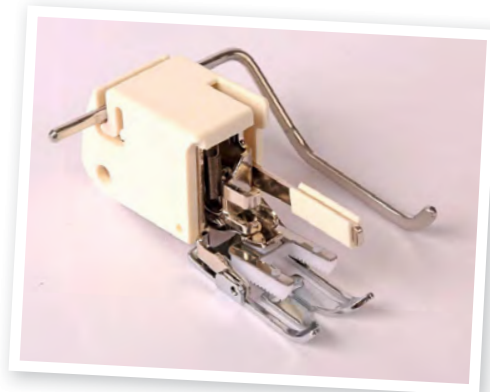

Pintuck foot

Pintucks are very small 'false tucks' created when parallel rows of stitching are created using a 2mm twin needle. This feature can be found used on dressy blouses and skirts as well as lingerie and nightwear, and is a technique often found in heirloom sewing projects for children's clothes and christening gowns.

They can also be used elsewhere, for example to add a unique touch to bed linen and other home furnishings. Janome's pintuck foot is specially designed to be used with a twin needle to create pintucks in multiple rows – the grooves on the underside of the foot mean it is easy to stitch several rows parallel and evenly spaced from each other.

Roller foot

As the name of this accessory suggests, it is equipped with rollers that roll against the fabric and are perfectly suited to sewing up and over heavy seams and uneven surfaces. This is a fantastic foot for those who sew regularly with heavier fabric or sew multiple layers of fabric together, as the rollers move freely between the foot and the feed dogs to ensure that the foot rides easily over varying thicknesses. It is also fantastic for handling sticky leathers and vinyl, so you can experiment with your makes.



Gathering foot

Another foot you'll wonder how you managed for so long without is the gathering foot, which makes creating soft gathers in lightweight fabric an absolute breeze. The foot's underside is raised behind the needle, and a thick bar in front of the needle gathers and attaches a ruffle onto your flat fabric simultaneously as you feed it through.

This is a fantastic way to cut some of the fuss from projects where gathers are required. It's important to bear in mind that this foot is specifically suited to lighter fabric, so while it is perfect for ruffles on lighter skirts and dresses, if you're looking to create gathers in heavier fabric, or create a more dramatic effect, the ruffler foot is better suited to the task.

Machine buying GUIDE

Whether you're buying your first sewing machine, upgrading to a mid-range model, or looking to splash some cash on something new and exciting, it's best to be informed. We're sharing our top tips for picking your new machine

Which sewing machine should I buy?

If you're just getting started sewing and aren't sure how much use you're going to get out of a sewing machine, you probably won't want to spend too much money on it. In which case, you might want to go for a mechanical model – with knobs as opposed to a digital display – as they are usually cheaper than their computerised counterparts.

Mechanical sewing machines tend to have a limited number of functions, but that's fine because you really don't need three

million different types of stitches for most dressmaking projects – as long as you've got straight stitch, zigzag stitch and a buttonholer, you're doing well.

Perhaps more importantly, they are generally better at handling thicker fabric or multiple layers of fabric.

Lower-end computerised machines often feature desirable extras, such as fancy stitches, a one-step buttonholer or an automatic thread cutter – things you don't necessarily need but that will make your (sewing) life a whole lot easier.

If sewing is a big part of your life, at some point you might decide to upgrade to a more professional model with unique functionality and level of design. A high-end machine with a powerful motor and strong guts will be able to handle all sorts of fabric types and multiple layers. They might even be faster to aid with speedy sewing and have the option to work without pedals!

TOP TIPS!

Don't scrimp, just look for the best price you can

Consider this an investment, like a good camera or bike. Don't buy cheap just for the sake of it, or scrimp on the features you know you'll miss in the future. Set a budget by prioritising quality and reliability.

Try before you buy

You might feel a bit silly about test driving a sewing machine before you buy but you might find out what you really want from a machine by practising on a couple of similar models in a store. Many Janome stockists offer free demonstrations to help you choose the right machine for you.

Shop local

There's definitely something to be said for buying a machine from your local Janome stockist. Firstly, because it's nice to support your community, but you can guarantee they'll want you to be happy and will be there for you when you need face-to-face support. Their business is built on happy customers so they'll do their best for you.





Should I buy an overlocker?

An overlocker is a specific sewing machine that finishes the edges of fabric to prevent it from fraying. If you turn a shop-bought T-shirt inside out you will see the seams have been neatened with an overlocker.

An overlocker is not necessarily a replacement for a sewing machine. In most cases it's an additional machine needed for creating a professional finish but on the right garments and fabric you can sew at least 80% of the construction

on one of these machines. For a closer look at how the moving parts of an overlocker work, turn to page 23.

For example, if you intend to sew a lot of jersey garments, it can be worth the investment as you'll be more confident in construction and will only use your main machine for small parts of the garment.

An overlocked seam will help handmade garments to last longer, through more wearing and washing. This is especially beneficial on children's clothing which gets put through its paces.

Overlockers often have a bad reputation for being hard to thread but they just need you to follow the instructions carefully - just like you would a sewing pattern. Each thread travels through the machine in a specific route and all threads have a set order. Colour coding and diagrams help prompt you to rethread the machine and several models come with an instructional DVD.

If you have the space and the budget we definitely recommend adding one of these excellent machines to your sewing room.

FOR YOUR NEAREST JANOME STOCKIST

SOUTH EAST

Barcham Sewing Machinery
Est. 1947. Industrial and Domestic Sales, Repairs, Parts and Accessories. Sewing Machine Traders Association (SMTA) Member
59 Harbour Street, Whitstable, CT5 1AG
www.barcham-sewing.co.uk
01227 264 271
info@barcham-sewing.co.uk

C & A Supply Co Ltd.
Online stockist for all your JANOME Sewing Machine Needs. New Machines, Accessories, Parts and Servicing. Visit our Web Shop or call us on the Number below. Visitors Welcome.
Unit 5 Williams Court, Little Mead, Cranleigh, Surrey, GU6 8NE
www.sewcompare.com
01483 267777

Eastleigh Sewing Centre
A friendly, family run business, with a wealth of knowledge. We have a range of Sewing Machines, Fabrics, Dress-making and Quilting Supplies Experienced technicians on site for machine servicing and repair
Eastleigh Sewing Centre
22 High Street, Eastleigh Hampshire, SO50 5LD
02380 650808
www.eastleighsewingcentre.co.uk

Eclectic Maker
We supply fabulous contemporary fabrics for patchwork, dressmaking and craft from leading design houses, plus patterns, haberdashery and notions. We are agents for Janome, Bernina and Elna sewing machines and over-lockers.
13 Station Parade, Tarring Road, WORTHING, West Sussex, BN11 4SS
01903 681000,
www.eclecticmaker.co.uk
hello@eclecticmaker.co.uk

Lewisham & Deptford Sewing Machines Ltd
EST over 50 years, Sewing Machine specialists, full workshop facilities with trained engineers on the premises. The south/east leading suppliers of every make, with branches in London & Kent.
www.sewingmachinesuk.co.uk
sales@sewingmachinesuk.co.uk
0208 692 1077
0208 692 0228

Reads of Winchester
Suppliers of sewing machines, both new and reconditioned. Many machines on display. Demonstrations available. Sales, service, repair Haberdashery supplies
Tel 01962 850950
1 St Thomas Street, Winchester Hants SO23 9HE

Sew Creative
Dedicated Janome & Elna approved stockiest in East Hampshire. Advice,

demonstration and test sew the latest models. Workshops to learn your new machine. Machine MOTs and full servicing.
Sew Creative, 20-22 Lavant Street, Petersfield, Hampshire GU32 3EW
01730 858020
www.sewcreative.org.uk
info@sewcreative.org.uk

Sew Devine
Family business established 1982. We offer FREE tuition in store on all Janome machines purchased from us. Suppliers of Janome sewing machines, embroidery machines and overlockers. FREE UK delivery
0118 926 8664
www.sewdevine.co.uk

Witney Sewing & Knitting Centre
We are proud to promote Janome, all under one roof, machines - fabrics - habby - wools-workshop - service & repairs - & free parking
01993 704535 or 01993 772702
www.witney-sewing-knitting.co.uk

SOUTH WEST

Bredons
Bredons is a family run business now in its fourth generation. Whether your interests lie in basic sewing, quilting or full embroidery we have the machine to suit your requirements.
3 Eastgate, East Street, Taunton, Somerset, TA1 3NB
01823-272450
www.bredons.co.uk
info@bredons.co.uk

Cotswold Sewing and Knitting Machines
Sewing Machines and Knitting Yarns. Machines Sales and Service Clothing Alterations and Repairs
7a Lansdown, Stroud, GL5 1BB
01453 763660

Direct Sewing Machines
We are a family Business est 1963. Selling Janomes for over 50 years Specializing in Sales Service and Tuition . Free tuition with our new machine.
www.direct-sewingmachines.co.uk
mail@direct-sewingmachines.co.uk
0117 9778216
46 Sandy Park Road, Bristol, BS4 3PF

Exeter Sewing
We're an agent and service centre for industry-leading brands of sewing, embroidery and overlocker machines. We also stock fabrics, haberdashery and yarn, and a hold variety of sewing workshops.
www.exetersewing.co.uk
info@exetersewing.co.uk

Hansons Fabrics
With over 20,000 rolls of fabric, yarns and haberdashery, to domestic

Janome sewing machines and accessories and popular all-day workshops with experienced tutors, Hansons Fabrics is the ultimate sewing experience!
Station Road, Sturminster Newton, DT10 1BD
01258 472698
info@hansonsfabrics.co.uk
www.hansonsfabrics.co.uk

So 'n' Sews
We are a family run business offering a wide range of dress making, home furnishing, quilting and craft fabrics; sewing accessories, haberdashery and Janome sewing and embroidery machines.
24 Westham Road, Weymouth, Dorset, DT4 8NU
01305766411
sales@sonsews.co.uk
www.sonsews.co.uk
www.facebook.com/sonsews

The Sewing Studio
Your one-stop-shop for Quilting. We stock the full Range of Janome Sewing Machines, haberdashery and arguably the largest range of Cotton Fabrics and Precut fabrics in the UK
www.thesewingstudio.co.uk
01209 216942
10 Chapel Street, Redruth, TR15 2DB

West End Sewing Centre Ltd
We have traded in Cheltenham for over 25 years giving us the experience and knowledge of the sewing machine market to offer and recommended the ideal machine for the customer.
11 Henrietta Street, Cheltenham GL50 4AA
01242 244025
www.westendsewing.co.uk
info@westendsewing.co.uk

WEST MIDLANDS

Abakhan - Hanley
We run free sewing machine demonstrations - please come and try before you buy! NEW Overlocking demos coming soon. Great in-store offers.
55 Old Hall Street, Hanley, Stoke-On-Trent, ST1 3AU
01782 274 200
Open 7 days

Creative Hands 2
A family owned business established 1970. Supplying a wide range of machines, patchwork and quilting products, haberdashery, craft and embroidery supplies. Tuition and classes available.
7 College Street, Worcester, WR1 2LU
01905 24940
www.creativehands2.co.uk

HarryandFloss
A fabric, yarn and haberdashery shop offering all major brands of wool and fabric such as Sirdar, King Cole,

Lewis and Irene and Moda. Several workshops available as well online shopping
4 Market Place, Alcester, B49 5AE
info@harryandfloss
www.harryandfloss.co.uk
07931095052

Parrs Sewing Machines
Doughty Fabrics are proud Stockists of Janome Sewing Machines, the Warehouse is well worth a visit for any quilter/ sewer.
DOUGHTY FABRIC WAREHOUSE
100 Barrs Court Road, Hereford. 01432 353951

The Shrewsbury Sewing Machine Centre
Now in our 60th year! Nestled at the bottom of historic Wyle Cop (Darwin and Dickens wrote here) , we supply all the big brands plus service and repairs to all makes.
58 Wyle Cop, Shrewsbury, Shropshire, SY1 1XJ
01743 343902
sewshrew@postmaster.co.uk

SCOTLAND

The Stitchery
Based in the heart of Glasgow, The Stitchery offers creative sewing classes taught by respected designers and artists. It's a place to make, to learn and to relax.
www.thestitcherystudio.com
[@stitcherystudio](https://www.facebook.com/thestitcherystudio)
0141 237 9690
info@thestitcherystudio.com
Third Floor, First Left, 24 Sandyford Place, Glasgow, G3 7EF

WALES

Abakhan - Mostyn
We run free sewing machine demonstrations - please come and try before you buy! NEW Overlocking demos coming soon. One day Sewing Machine classes, £42.50 includes all materials and equipment.
Book Online www.abakhan.co.uk
Coast Road, Llanerch-y-Mor, Mostyn, North Wales, CH8 9DX
01745 562 100
Open 7 Days

Sewing Machines Direct
Specialist retail & online suppliers of sewing & embroidery machines, overlockers, embellishers & accessories. Free impartial advice/ demonstrations. Extensive range of top brands available from stock. First class customer service & in-house servicing/repairs.
SMD Court, Miners Road, Llay Industrial Estate, Llay, Wrexham, LL12 0PJ
0800 622 6224 or 01978 851235
www.sewingmachines.co.uk

Janome Sewing SCHOOL

Are you thinking about taking a creative class? Whether you want to learn a new skill, meet like-minded people or get to grips with your machine, there will be a session for you

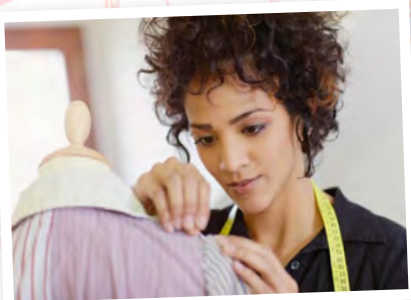

The Janome courses take place at the Janome Sewing School, Southside, Bredbury, Stockport SK6 2SP. This fabulous purpose-built training facility is located on the ground floor of the Janome Centre and is light and spacious. Sewing machines are provided for your use during the day and a light buffet-style lunch is included in your course fee. All sessions start at 10am and run until 4pm.

You'll find the Janome centre only seven miles south of Manchester and approximately two and a half hours from London by train. The location is within easy access of the M60 motorway and there is ample on-site parking.

Contact information to book each course can be found below as many sessions require booking directly with the tutor. Demand for places is high so please book early to avoid disappointment.

Meet the tutors!

Gill Arnold

Gill has her own studio in Birmingham where she offers a comprehensive programme of hands-on dressmaking and tailoring courses. Her career in theatre costume, clothing manufacturing, couture dressmaking and teaching has provided her with a wealth of knowledge that she enjoys passing on to others. Gill gives talks on a variety of sewing-related topics and is a regular contributor in the lecture halls at the Sewing for Pleasure Show, National Exhibition Centre Birmingham.

Dionne Swift

Dionne Swift is an award-winning textile artist and tutor with over 25 years' teaching experience. Having graduated from Goldsmiths College, she now exhibits internationally and works from her Pennine garden studio. She offers guidance and confidence to beginners but knows when and how to stretch the more experienced practitioner. Look out for Dionne at the prestigious Knitting and Stitching shows, she will be showcasing a new collection of work as a featured exhibiting artist this year.

Celia Banks

Celia teaches a wide range of sewing topics, from beginners' sewing to tailoring. She specialises in teaching the Palmer/Pletsch method of tissue fitting to produce perfectly fitted garments and is its only associate educator in the UK and Europe. She teaches in a variety of locations in the UK and runs an annual Sewfest in Aarhus, Denmark.

Ann White

Ann works as training co-ordinator at the Janome Sewing School teaching classes on

the top-of-the-range embroidery machines. She is a fountain of knowledge and also works as part of the Janome team at major sewing exhibitions throughout the UK.

Sandra Coleridge

Sandra is a textile artist who has exhibited widely and has undertaken numerous private commissions. She has many years of teaching experience, running classes at her home, embroiderers' groups, guilds, private venues and residential colleges all over the country. She has specialised using the Janome FM725 embellisher since its introduction. Much of Sandra's exhibition and teaching combines the embellisher and free machine embroidery techniques.



2016 Dates	Class	Tutor
Monday 19th September	Overlocker Masterclass	Gill Arnold
Tuesday 20th September	Fabric manipulation	Dionne Swift
Wednesday 21st September	Essential techniques for shirts and blouses	Celia Banks
Tuesday 27th & Wednesday 28th September	Painting with stitch (two days)	Dionne Swift
Tuesday 11th & Wednesday 12th October	Fabric sketchbooks (two days)	Dionne Swift
Tuesday 18th October	Feet and Accessories	Ann White
Wednesday 19th October	Fine tune your dressmaking	Celia Banks
Tuesday 1st November	Free motion embroidery and dissolvable fabric	Dionne Swift
Wednesday 16th & Thursday 17th November	FM725 embellisher creative workshop (two day)	Sandra Coleridge



FM725 embellisher creative workshop (two days) With Sandra Coleridge

Join Sandra for an exciting two-day workshop exploring many new techniques. The first day will be spent making fabric on the FM725 embellishing machine to make a 3D object, ie a handbag, box or container. On the second day you will be using free-motion machine stitching to enhance your fabric and complete the project.

Course materials are included for a small project with supplies also for sale on the day.

Price: £150
Telephone: Sandra Coleridge, 01884 277589
Email: sandracoleridge@mac.com
Website: www.sandracoleridge.com



Fabric Manipulation With Dionne Swift

Ever wondered how to create the perfect pleat? Fascinating fold? Tidy tuck? Ravishing ruffle? During this one-day wonder workshop you'll discover the full potential of the humble straight stitch and zingy zigzag. Often overlooked, these simple stitches can create tremendous textures that will transform all your homemade projects. With the addition of some simple stitches, a basic cushion cover can become a sumptuous surface!

You'll look at 'the bias', create 'faux chenille', make wavy lettuce edges, dabble with

translucent fabric, pinch out pintucks, wonder about waves and consider how you can create unique projects with your new skills! You'll leave with bundles of samples and a head full of ideas!

All the fabric and extras will be provided; all you need to bring is your energy and enthusiasm!

Price: £70
Telephone: Dionne Swift, 07974 747080
Email: info@dionneswift.co.uk
Website: www.dionneswift.co.uk/workshops-at-other-venues

Feet and Accessories: Mysteries unravelled With Ann White

Spend an exciting day unravelling the mysteries of how to use an array of interesting feet and accessories. During the day a sample piece will be created using several different feet and accessories. This piece can then be made up later into a project of your choice.

Examples of the feet and accessories used are:

- Circular attachment
- Pintuck foot & guides

- Piping foot
- Bias binding foot
- Gathering foot
- Ruffler foot
- Border guide foot

A kit will be supplied containing everything you need.

Price: £70
Telephone: Janome Sewing School, 0161 666 6006
Email: training@janome.co.uk





**Painting with stitch
(two days)
With Dionne Swift**

The thread is your paint, the machine your brushes! Using free machine embroidery, discover new techniques to develop texture and colour mixing – create depth and stunning compositions in stitch.

Over two days, your eyes will be opened to the spectacular world of embroidered art: Kirstie Allsopp said ‘machine embroidery is the crack cocaine of the textile world’ – she’s hooked and you will be too!

Create reference samples and develop a significant finished piece. Learn all Dionne’s hints, tips and secrets to successful stitchery!

Price: £140
Telephone: Dionne Swift, 07974 747080
Email: info@dionneswift.co.uk
Website: www.dionneswift.co.uk/workshops-at-other-venues

**Free-motion embroidery
and dissolvable fabric
With Dionne Swift**

Discover the creative potential of thread and stitch in combination with dissolvable fabric. You’ll learn how to draw with a sewing machine and explore the delights of creating delicate lace like items and how to consider colour mixing and varied thread types too.

Dionne will have a series of examples to assist and inspire your creations, you don’t need to worry about the design, simply enjoy discovering a new method of working.

All the skills you’ll learn are transferable to other projects – these techniques are a delightful way to make unique gifts and you can decide on the day to make a brooch, earrings and/or a necklace or simply embrace this unique process.

All the relevant materials will be provided – you just need to bring an open mind and be ready to play!

Price: £70
Telephone: Dionne Swift, 07974 747080
Email: info@dionneswift.co.uk
Website: www.dionneswift.co.uk/workshops-at-other-venues

**Fabric Sketchbooks
With Dionne Swift**

As with Dionne’s ‘original’ developing sketchbook workshop, she’ll help you get over your fear of the blank page (plain fabric). Together you’ll look at ways to gather research, to observe and develop/play with imagery and cloth – it’s a two-day jam-packed extravaganza of fabric and thread exploration. All being well, you will make a fabric book bubbling over with stitch and needle punch

exercises: think of it as a tactile dictionary of techniques to refer to again and again.

This is an invaluable workshop for anyone hungry for more ideas to play with and who wants to explore sewing and embellishing machines.

Price: £140
Telephone: Dionne Swift, 07974 747080
Email: info@dionneswift.co.uk
Website: www.dionneswift.co.uk/workshops-at-other-venues



Essential Techniques – Shirts & Blouses With Celia Banks

Having a great-fitting shirt or blouse is essential but being able to make changes to a pattern will expand your wardrobe.

This class will introduce you to different ways of completing collars, cuffs, hidden yoke seams, button stands and sleeve plackets, including the Palmer Pletsch 'painless sleeve placket'. Being able to produce perfect matching collar points and reduce the bulk around cuffs will take your sewing to a higher level. You will learn how to sew the most appropriate seams for different situations, using different machine feet and also how to handle a variety of shirt and blouse fabric.

This class is suitable for all skill levels and all materials are provided. Students will complete a portfolio of samples for future reference.

Price: £70

Telephone: Ceila Banks, 07790 036975

Email: celia.banks@sew-fundamental.co.uk



Fine tune your dressmaking With Celia Banks

This full day, practical masterclass will teach you great techniques to develop your dressmaking skills. Learn how to sew darts without bubbles on woven or knit fabric. Speed up hemming by perfecting machine, blind and rolled hems and discover how easy setting in sleeves can be. Learn how to make pocket flaps and collars with hidden seams and discover how to manage difficult fabric. Use classic

couture techniques to sew difficult corners and godets.

You will create a portfolio of samples for future reference using the materials provided. It is suitable for most ability levels, but attendees do need to be able to know how to use a sewing machine for straight stitching.

Price: £70

Telephone: Celia Banks, 07974 747080

Email: celia.banks@sew-fundamental.co.uk

Overlocker masterclass With Gill Arnold

Whichever brand of overlocker you have, this workshop is designed to give you confidence to operate an overlocker to its full potential. Learn to thread the overlocker and adjust the cutting width, length and differential feed settings to perform various techniques using a variety of fabric.

You will compile a booklet of overlocking reference samples to take away.

Price: £70

Telephone: Gill Arnold, 0121 608 1414

Email: training@gillarnold.co.uk

Website: www.gillarnold.co.uk





Around
£2,199

Spotlight on the Horizon MEMORY CRAFT 9400 QCP

The time spent behind your sewing machine is some of your most precious, so you deserve a machine that lets you get the most out of it. That's why Janome has released a brand-new sewing machine for the experienced quilter



Created with special, easy and time-saving features, the MC9400 QCP is unlocking limitless possibilities for quilters to escape into a world of pure creativity. Your working area is now a full 11" of bed space to the right of the needle to store extra fabric from a quilt.

What's more, quilters can enjoy exceptionally smooth quilt piecing with the included AcuFeed™ Flex Layered Fabric Feeding System; achieve faster performance with a sewing speed of 1,060 SPM and view their

work, shadow-free, with the machine's retractable High Light™. Navigation through all of these features has become easier with the MC9400's new LCD colour touchscreen.

There is also a USB Port for Direct PC Connection. We've been wowed by the 350 built-in stitches and four alphabets available and when paired with the variable zigzag for free-motion quilting, the creative options are endless.





HORIZON®

Two stunning Computerised Long-arm Models

We've added even more fabulous features to create the amazing Memory Craft 8900QCP and the Memory Craft 8200QCP Special Edition sewing machines. The sheer length of the arm space at 280mm (11") makes them ideal for those larger projects.

With a great range of stitches and alphabets, 9mm stitch width, pattern elongation up to 5 times standard length and a built-in AcuFeed system for precise fabric handling, these models can meet every sewing challenge. Then add an easy change needle plate to enhance straight stitch performance, a new easy set bobbin system, an automatic needle threader, an easy bobbin winder, a maximum speed controller and a start/stop button if you choose not to use the foot control and you start to realise how complete these machines are. You can rest assured they offer spectacular stitch quality at speeds up to 1,000 stitches per minute and there is even a memory to store stitch combinations, a knee lifter and a remote thread-cutter port on the MC8900QCP Special Edition!

It doesn't matter whether you are quilting, dressmaking, crafting or making home furnishings, with creativity this easy you'll just want to get started.



MEMORY CRAFT 8200QCP
SPECIAL EDITION



MEMORY CRAFT 8900QCP
SPECIAL EDITION

**For further information:
Telephone 0161 666 6011 or visit www.janome.co.uk**

The World's leading sewing machine manufacturer

JANOME



MC15000

The incredible Memory Craft 15000v2 incorporates all the best features for sewing, embroidery, quilting and craftwork and has the largest work area of any equivalent model available. It's the first machine of its kind to have Wi Fi, the first to work with an iPad and the first to have its own Apps!



MC14000

This long arm combined sewing and embroidery machine has many of the features found on our top of the line Memory Craft 15000 for sewing, embroidery, quilting and craftwork.



MC9900

The Memory Craft 9900 is a combined sewing and embroidery machine. It offers lots of powerful features for sewing as well as professional-style embroidery at home. It also has 3 inter-changeable coloured panels to personalise your machine.



MC500E

The Memory Craft 500E is a dedicated embroidery only machine and offers professional-style embroidery at home, capable of designs up to 200 x 280mm. It's easy to embellish garments, furnishings and accessories.

For limitless embroidery possibilities optional embroidery design software is available which can convert artwork into stitches and stitches into works of art.

For further information:
Telephone 0161 666 6011 or visit www.janome.co.uk

The world's leading sewing machine manufacturer

Go ahead... get creative!

Add a decorative touch of beautiful embroidery to fit your lifestyle

The world of Janome professional style embroidery brings amazing tools to your creative talents. Janome embroidery machines utilise intuitive technologies.



JANOME