

IRISH CROCHET
IN WHITE
AND IN COLOR

OVAL MAT WITH BRUGES LACE

DECORATIVE CROCHET

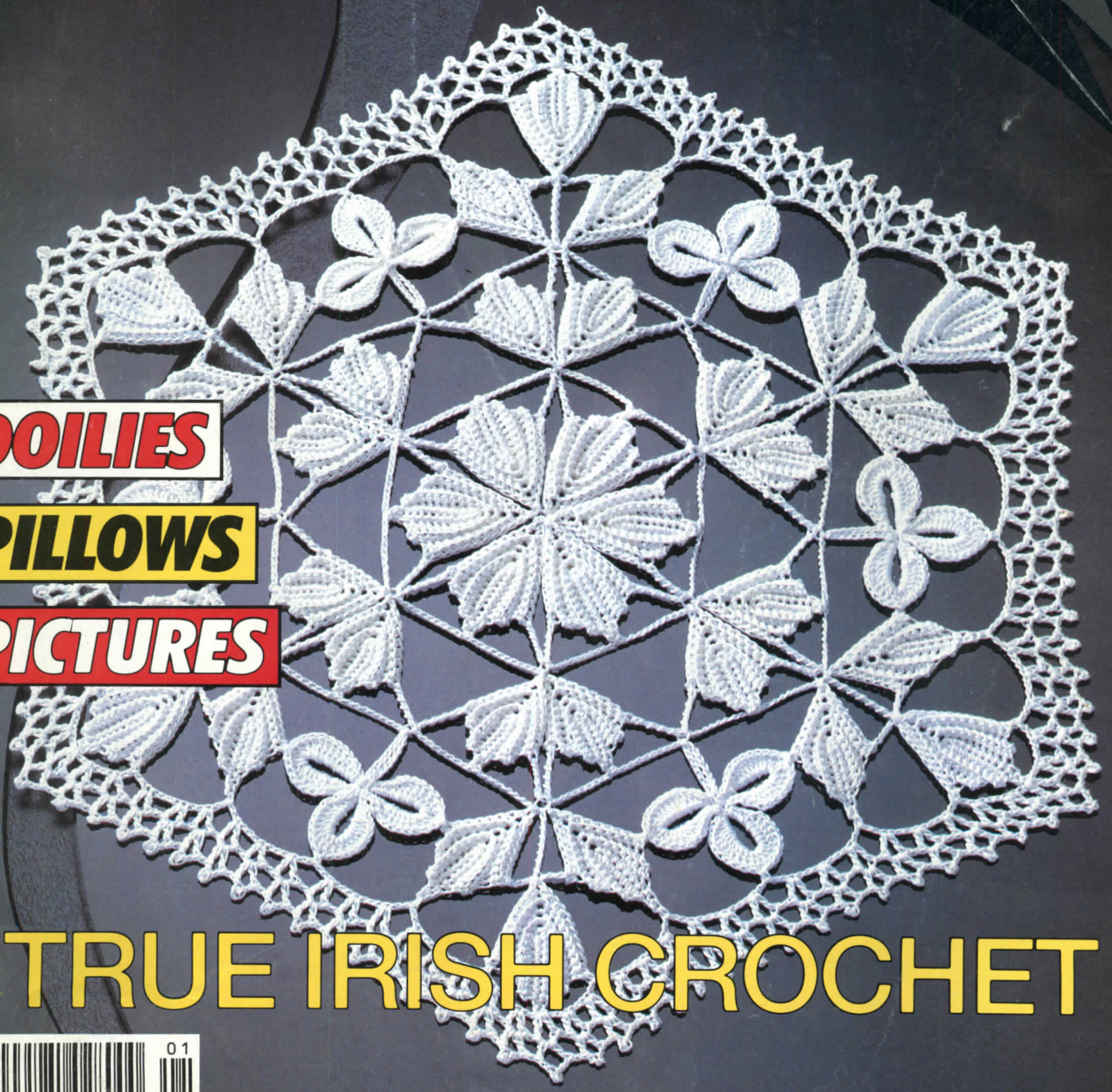

DOILIES

PILLOWS

PICTURES

TRUE IRISH CROCHET



JANUARY 1993 - Number 31 - \$ 3.25 - Canada \$ 3.25

Statement required by the Act of August 12, 1970, Section 3685 Title 39, United States Code, showing the ownership, management and circulation of DECORATIVE CROCHET, (Publication No. 004818), published bi-monthly, (6 times per year) at Patterson, NY as filed September 29, 1992. Annual subscription price is \$ 15.50. Complete mailing address of known office of publication is P.O. Box 5700, Robin Hill Park-Route 22, Patterson, NY 12563-0830. The names and addresses of the publisher, editor and director-in-charge are: Publisher, Les Editions de Saxe S.A.; Editor, Paulette Rousset, Director-in-charge, Guy Rousset, all of 20, rue Croix-Barret, 69358 Lyon Cedex 7, France. The owners are: Les Editions de Saxe S.A., 20, rue Croix-Barret, 69358 Lyon Cedex 7, France, and Guy Rousset and Paulette Rousset, both of 20, rue Croix-Barret, 69358 Lyon Cedex 7, France. The known bondholders, mortgagees and other security holders owning or holding 1 percent or more of the total amounts of bonds, mortgages or other securities are Guy Rousset and Paulette Rousset, both of 20, rue Croix-Barret, 69358 Lyon Cedex 7, France. Extent and nature of circulation are as follows. Average number of copies of each issue during the preceding 12 months and the actual number of copies of the single issue published nearest the filing date, are, respectively, as follows: total number of copies (net press run) 196,472-195,118; paid and/or requested circulation - sales through dealers and carriers, street vendors and counter sales 30,574-28,549; mail subscription (paid and/or requested) 87,005-89,645; total paid and/or requested circulation 117,579-118,194; free distribution by mail, carrier or other means samples, complimentary, and other free copies 39-38; total distribution 117,618-118,232; copies not distributed - office use, left over, unaccounted, spoiled after printing 4,603-2,810; return from news agents 74,251-74,076; total 196,472-195,118. I certify that the statements made above are correct and complete. Paulette Rousset Editor



LES EDITIONS DE SAXE
20, rue Croix-Barret
69358 LYON CEDEX 7 (France)
Director in charge : GUY ROUSSET
Editor : PAULETTE ROUSSET
DECORATIVE CROCHET
(ISSN 0994.2114)
published bi-monthly
by LES EDITIONS DE SAXE S.A.
69358 LYON CEDEX 7 FRANCE
Rate: \$ 3.25 per copy : \$ 16.25
per year in the U.S. and territories.
Second class postage paid at
Patterson, NY 12563 and at
additional mailing offices.
Issue no. 31 - January 1993
© 1992 LES EDITIONS DE SAXE S.A.
© T. Seto
All rights reserved. Reproduction in any
manner in whole or in part, except as
authorized by the Copyright Act,
is prohibited.
POSTMASTER : send address changes
to DECORATIVE CROCHET,
Subscription Dept.
PO BOX 5700
PATTERSON, N.Y. 12563
in CANADA, send address changes
to DECORATIVE CROCHET
Subscription Dept.
279 Humberline Drive
Rexdale, Ontario M9W 6L1
Printed in USA
Canadian goods and services
tax registration number R124617572
2

Dear Crochet Friends,

Irish crochet is a perennial favorite with most of you. Did you know that its popularity dates back almost two hundred years?

The story goes that nuns from Italy or France introduced this craft into Ireland. It was essentially an imitation of Venetian lace and was taught to convent-educated girls. During the potato famine in the mid-nineteenth century, crochet became a cottage industry and an important source of income for the Irish. From then on, this style developed its own stitches and techniques, flowering into a unique ornamental art form. As in guipure lace, shell-petalled flowers are held together with a network of chains and picots. The flowers are sometimes flat and sometimes raised. Dainty leaves are worked over filler cords to produce a three-dimensional effect.

Over the years, Irish crochet has been in and out of fashion many times. Right now it is reaching the crest of the wave, and many of you have let us know that you like it as much as we do.

The patterns in this issue of DECORATIVE CROCHET call for classical white thread, but we have added a modern touch by redesigning some of them in striking color. The result is positively sensational. It makes for cushion tops and mats so beautiful that they're just asking to be framed!

And as long as the subject is ornamental openwork, we have invited Bruges lace to join the party: combined with raised flowers it produces an oval mat that is sheer harmony.

Tastefully displayed throughout the home, these crochet-grown flowers will add a touch of nostalgia to your interior.

*Sincerely yours,
Paulette ROUSSET*



FOR STITCH
AND DIAGRAM HOW-TOS
SEE CROCHET BASICS
AT THE END OF THE MAGAZINE

1 JUMBO CHERRIES



By Glendola Hodges



SIZE:
14 1/4" by 16"

MATERIALS:
Shiny quality crochet cotton (or use fil d'Ecosse) no. 10, white, about 205 yds. Steel crochet hook US size 4 or SIZE FOR GAUGE.

GAUGE:
4" square = 11 meshes and 12 rows. TO SAVE TIME, TAKE TIME TO CHECK GAUGE.

TO MAKE:

Pillowtop: Ch 127 + 5 to turn (3 ch count as first dc and 2 ch form first open mesh or om). ROW 1: Dc in 9th st from hook, then work * 2 ch, sk 2 sts, dc in next st, rep from * across = 42 om in all; ch 5, turn each row. ROW 2: 14 om, 2 solid meshes <sm> (= * 2 dc in ch-2 below, dc in dc, rep from * once more), ** 2 om, 2 sm, rep from ** twice more, 14 om. ROWS 3-42: Work following pat diagram.

Edging: At end of row 42, ch 1 to turn and work 1 rnd all around pillowtop as per detail; close with sl st in first sc. Fasten off (see black wedge).

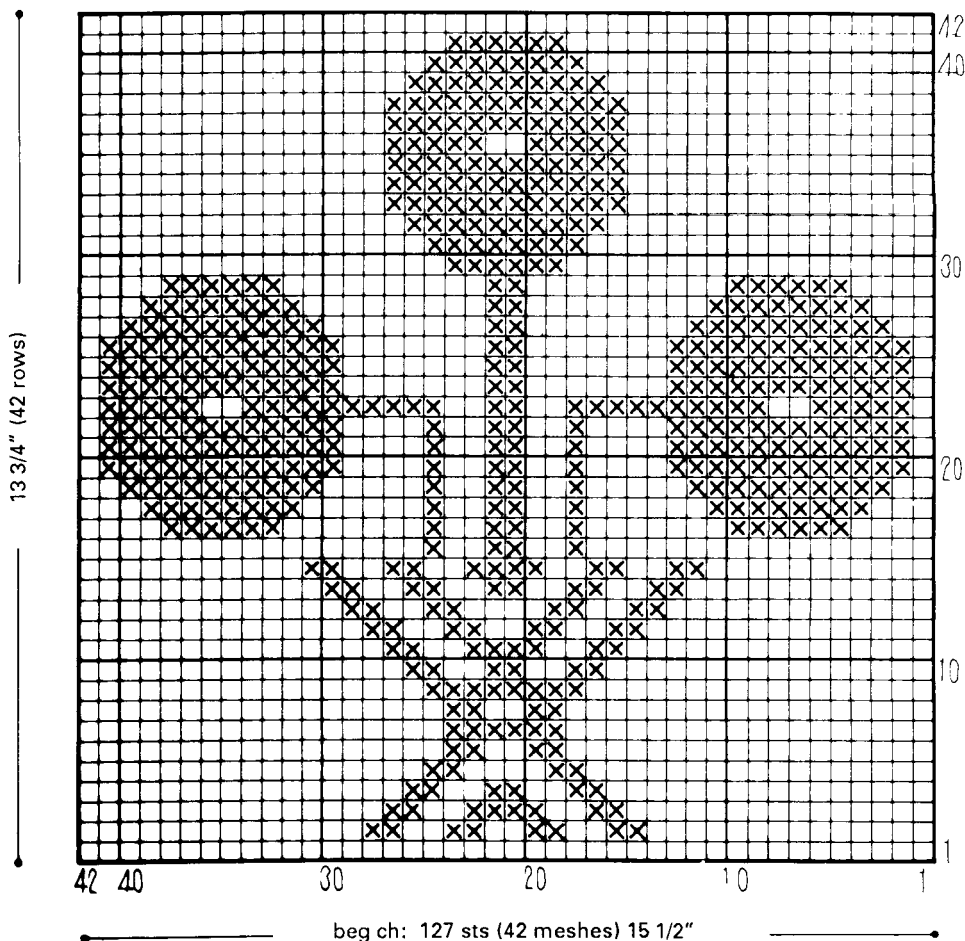
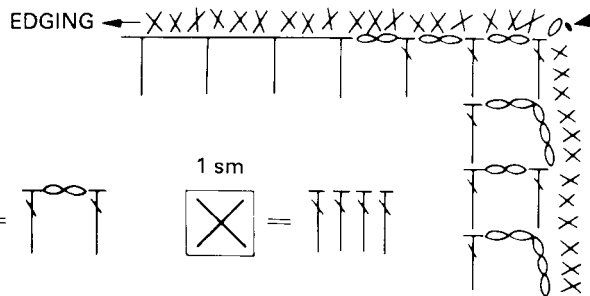

GAUGE: 4 ins square =
11 meshes and 12 rows

2 MOSAIC

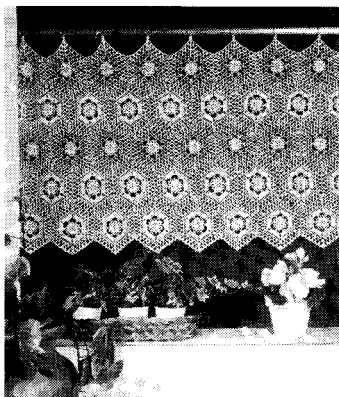

By Kyoko Takagi

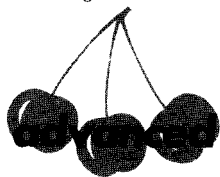

SIZE:
About 21 1/2" by 46 1/2".

MATERIALS:
Cordonnet crochet cotton no. 40, white, about 1,680 yds. Steel crochet hook US size 11 or **SIZE FOR GAUGE.**

TO MAKE:
Motifs A and C: Ch 8 and join with sl st to form ring. **RNDS 1-8:** Work following diagram and additional symbol for 3-tr cluster; close first 2 rnds with sl st in first sc. At beg of rnd 3, work 2 sl sts to

beg rnd in first ch lp. On rnd 3, replace last 3 ch sts with dc worked in top of first cl. On rnd 4, close with sl st in top of ch-3 (= first dc throughout). On rnd 5, work tr of motifs A in ch lps; close this rnd with sl st in top of ch-4 (= first tr throughout). On rnd 6,

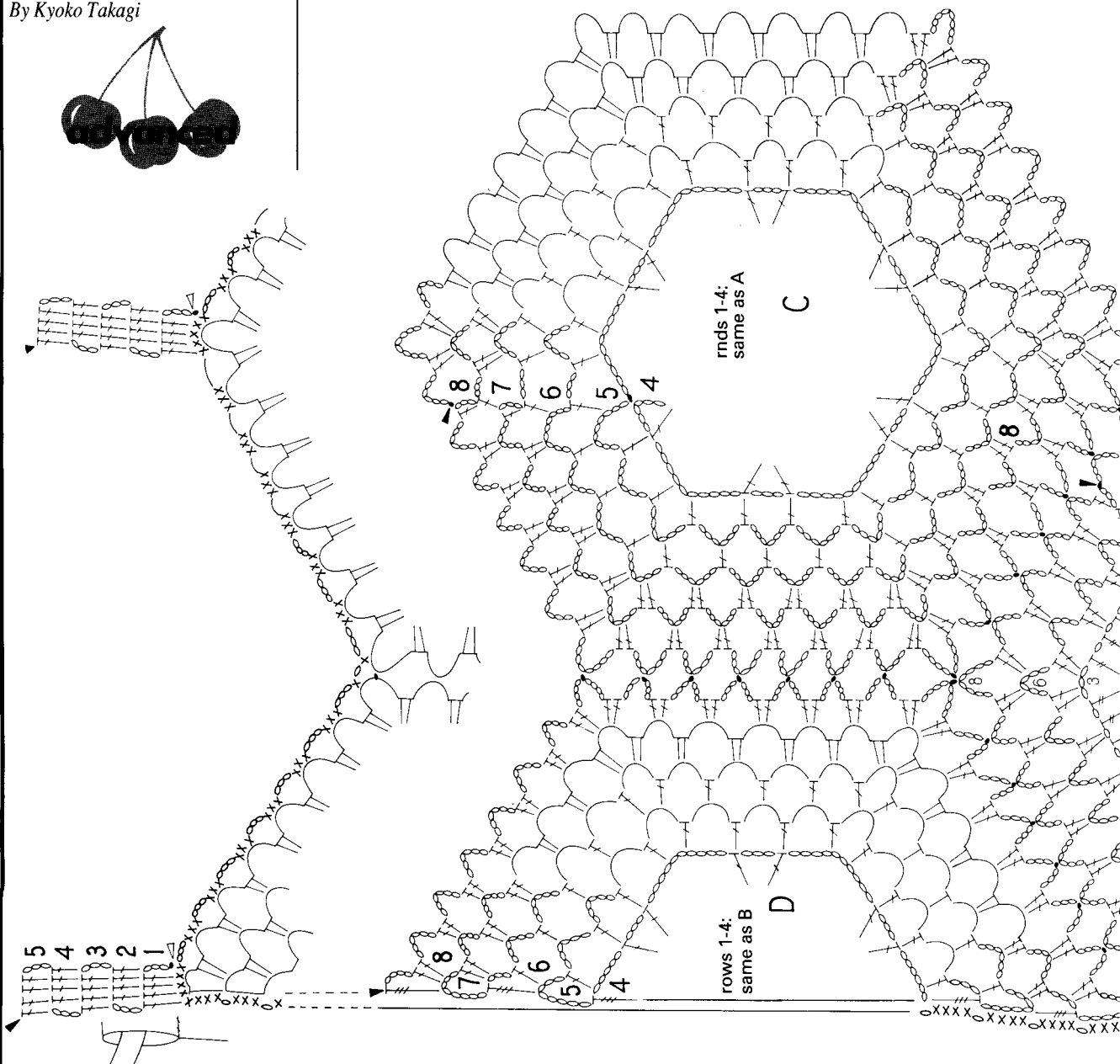

2 MOSAIC

replace last ch st of motif A with hdc worked in top of ch-4, last 3 ch sts on rnd 7 with dc. On rnd 8, close with sl st and fasten off. For motif C, replace last 3 ch sts on rnds 5 to 7 with dc worked in top of ch-3. As of 2nd motif, join on rnd 8 thus: work sl st in center of

corresp ch lps as shown on diagram. Arrange motifs as per Assembly Diagram.

Motifs B and D: Ch 5 and work dc in first st of ch-5 just made; ch 1, turn. ROW 1: Sc in dc, 5 sc in ch lp, sc in same st as dc; ch 1, turn and cont working back and

forth in rows following diagram; for dtr on ends of rows work thus: yo 3 times, pull up lp in st, yo and work off lps on hook 2 by 2. On row 8, join in same way as you joined motifs A and C.

Edging: When all motifs are joined, RS facing attach thread

with sl st and work 1 rnd all around motifs; close with sl st in first sc. Fasten off.

Hanging loops: For each work 5 rows in dc as shown. Insert rings, sew 5th row to edge of curtain, on WS.

GAUGE: rnds 1-4 = 1 5/8 ins across

ASSEMBLY DIAGRAM

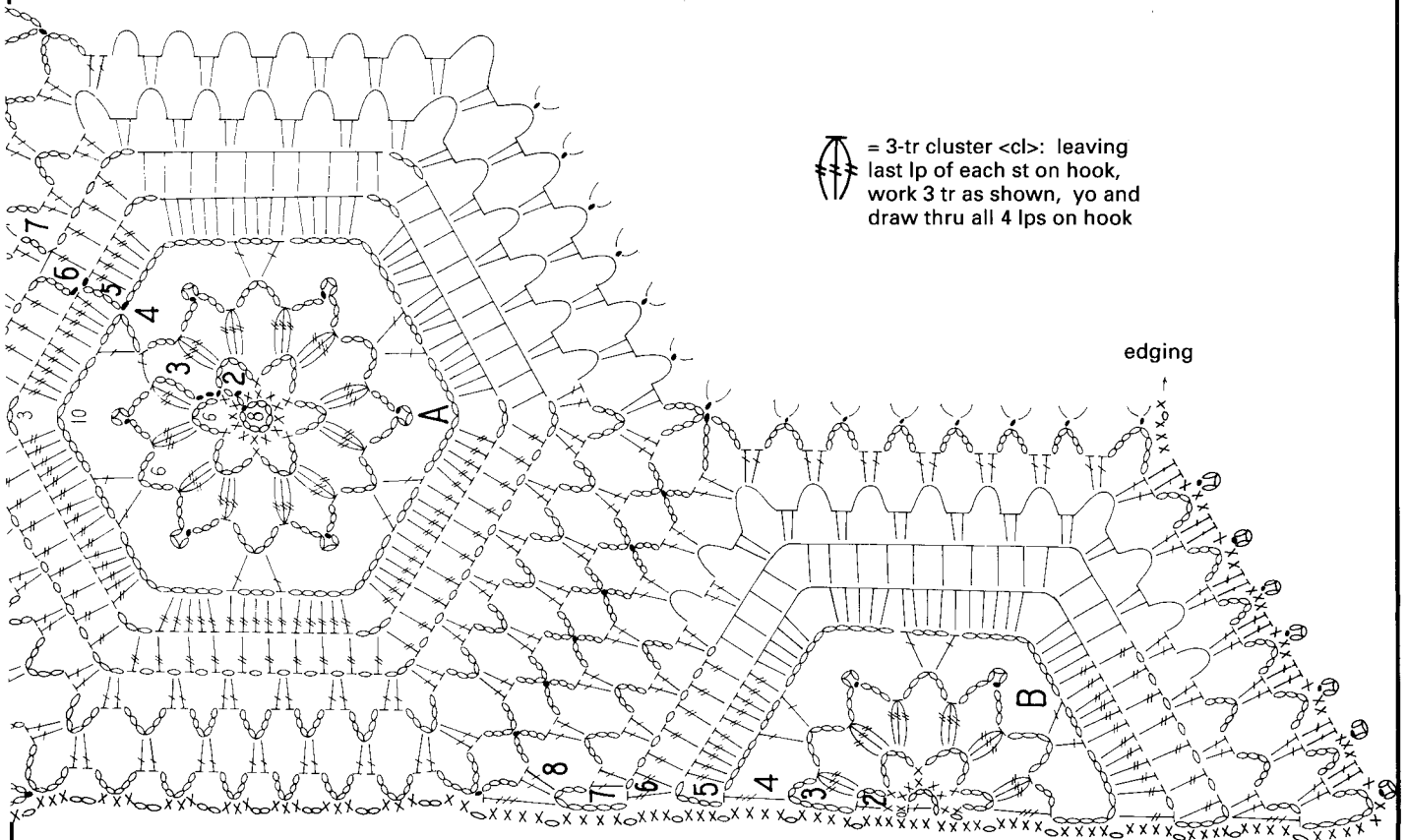
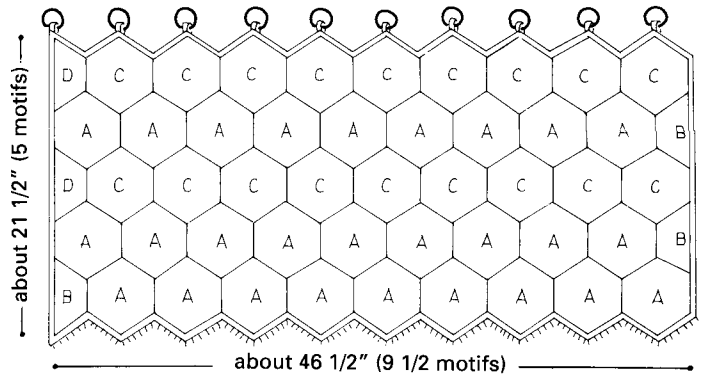

3 IN THE PINK

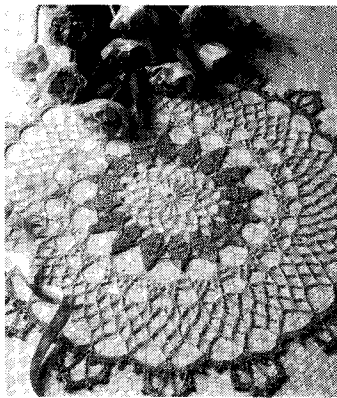

By Elizabeth Hiddleson

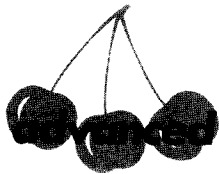

SIZE:
18 1/2" in diameter.

MATERIALS:
Cordonnet crochet cotton no. 10, about 140 yds pink and about 85 yds white. Steel crochet hook US size 7 or **SIZE FOR GAUGE**.

GAUGE:
First 2 rnds measure 2 3/4" in diameter.

TO MAKE:
Using white, ch 8 and join with sl st to form ring. **RND 1:** Ch 10, work * 1 quadruple triple crochet <quad tr> (= yo 5 times, pull up lp in beg ring, yo and draw thru 2 lps on hook 6 times in all), 3 ch, rep from * 14 times more; close with sl st in 7th st of ch-10. **RND 2:** Ch 1, beg in same st as closing sl st work * sc in top of quad tr, 6 ch, rep from * around; replace last 3 ch sts with dc worked in first sc. **RNDS 3-4:** Insert hook in ch lps below and work following

diagram. On rnd 3, end same as on rnd 2. On rnd 4, close with sl st in closing dc below. Cut white. **RND 5:** Attach pink with sl st in any ch-7 lp (see white wedge), then, in each ch lp around, work 6 tr and 3 ch; up to rnd 7, close with sl st in top of ch-4 (= first tr throughout). **RNDS 6-7:** Bet 6-tr grps work 5 ch on rnd 6; on rnd 7, work 4 ch, sc over ch lps on both rnds below and 4 ch. **RND 8:** *** 5 ch, 4-dtr cl (= ** yo 3 times, pull up lp in next st, * yo and draw thru 2 lps on hook, rep from * twice more, rep from ** thrice more, yo and draw thru all 5 lps on hook), 5 ch,

sl st in next st, 4 ch, sl st in first tr on next grp, rep from *** around. Cut pink. **RNDS 9-15:** Attach white with sl st in top of any cl, ch 1 and work following diagram and additional symbols. **RND 16:** Work ** 4 dc, 1 picot <p>, 9 dc, 1 p and 4 dc in ch lp, 4 dc, 1 p and 5 dc in next ch lp, 7 ch, turn, work (1 quad tr, 7 ch) twice as per tiny arrow A, sl st in 5th dc of 9 dc

arrow B, cont with 5 dc, 1 p and 4 dc in each of first 2 ch lps, 4 dc, 1 p and 5 dc in next ch lp, sl st in top of dc outlining ch lp, 4 dc, 1 p and 4 dc in ch lp on rnd 15, rep from ** around; close with sl st in top of ch-3 (= first dc). Fasten off (see black wedge).

GAUGE: rnds 1-2 are 2 3/4" across

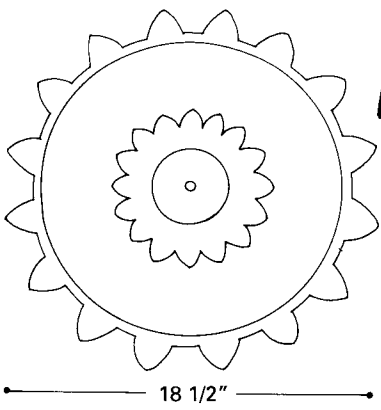
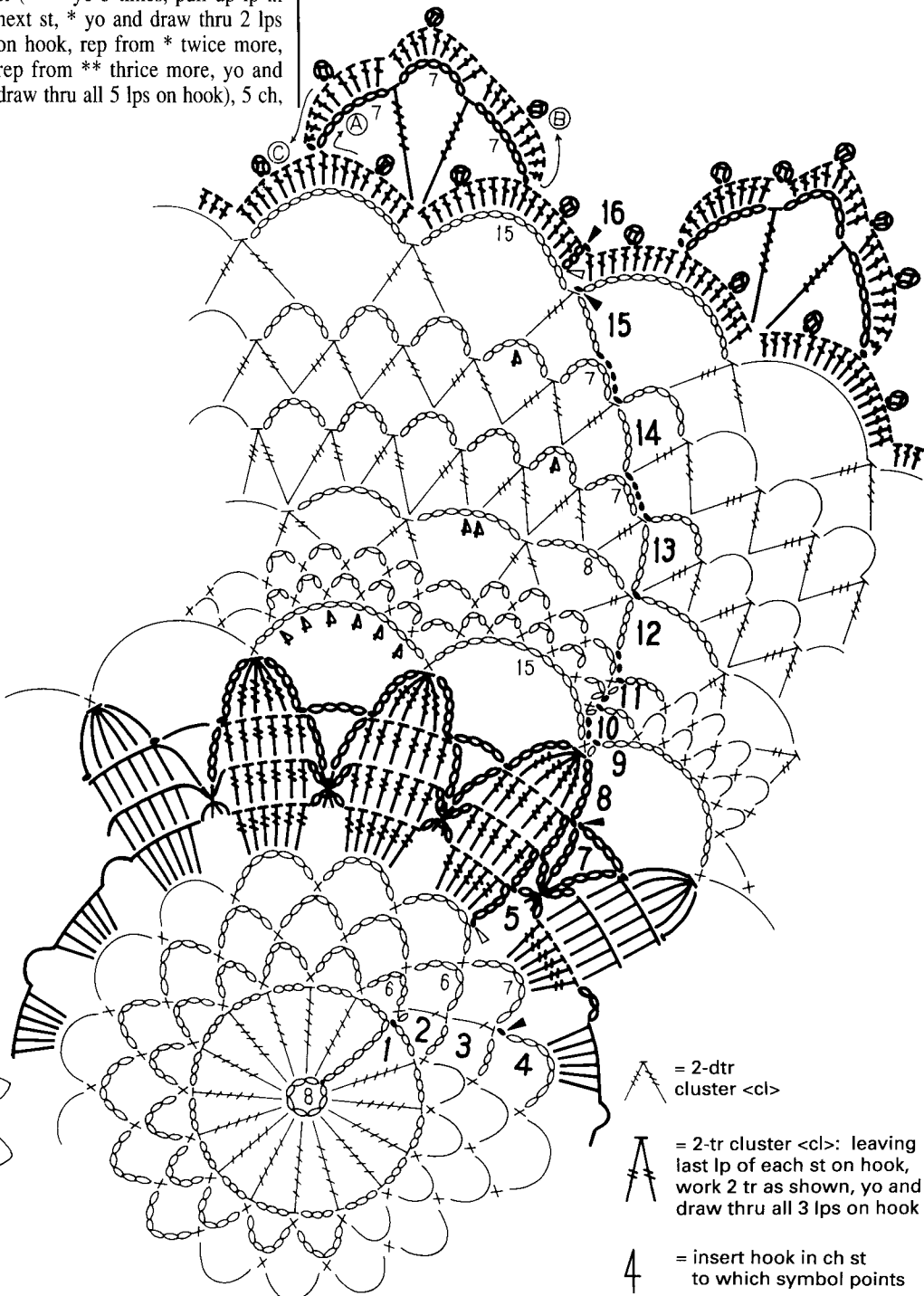





2
H

3
H





4 FRONT PORCH

By Michèle Charpentier

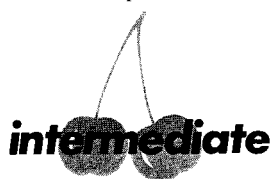

This is a rewarding way to practice your clusters.

SIZE:

Pillowtop is 17" in diameter.

MATERIALS:

Lustrous crochet cotton no. 5, ecru, about 212 yds (four 10-gram balls). Steel crochet hook US size 7 or **SIZE FOR GAUGE**. Round lined pillow 17 3/4" in diameter.

GAUGE:

First 3 rnds measure 3 1/4" in diameter.

TO MAKE:

Ch 20 and join with sl st to form ring. **RND 1:** In ring work 36 tr; close with sl st in top of ch-4 (= first tr throughout). **RND 2:** Ch 1, work (sc in top of tr, 9 ch, sk 5 tr) 6 times; close with sl st in first sc. **RND 3:** Work * 3-tr cl (see

additional symbol) in sc, 5 ch, 4 tr in 5th st of ch-9 lp, 5 ch, rep from * around; up to rnd 19, close each rnd with sl st in top of first cl. **RNDS 4-7:** Work following diagram. **RND 8:** ** 3-tr cl in top of cl below, 6 ch, 4-tr cl (= leaving last lp of each st on hook, work tr in each of next 4 tr, yo and draw thru all 5 lps on hook), * 5 ch, 4-tr cl having 1 tr in each of next 4 tr, rep from * twice more, 6 ch, rep from ** around. **RNDS 9-19:** Work following diagram. On rnd 9, work 5-tr grps in 3rd st of ch-5 lps below; on rnd 11, in 3rd ch st before and after each 5-tr cl. At

end of rnd 19, fasten off (see black wedge).

GAUGE: rounds 1-3 are 3 1/4 ins across

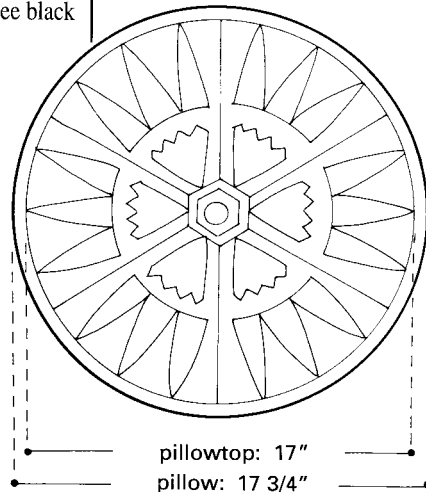

 = 3-tr cluster <cl>: leaving last lp of each st on hook, work 3 tr as shown, yo and draw thru all 4 lps on hook; work 4-tr and 5-tr cls in same way

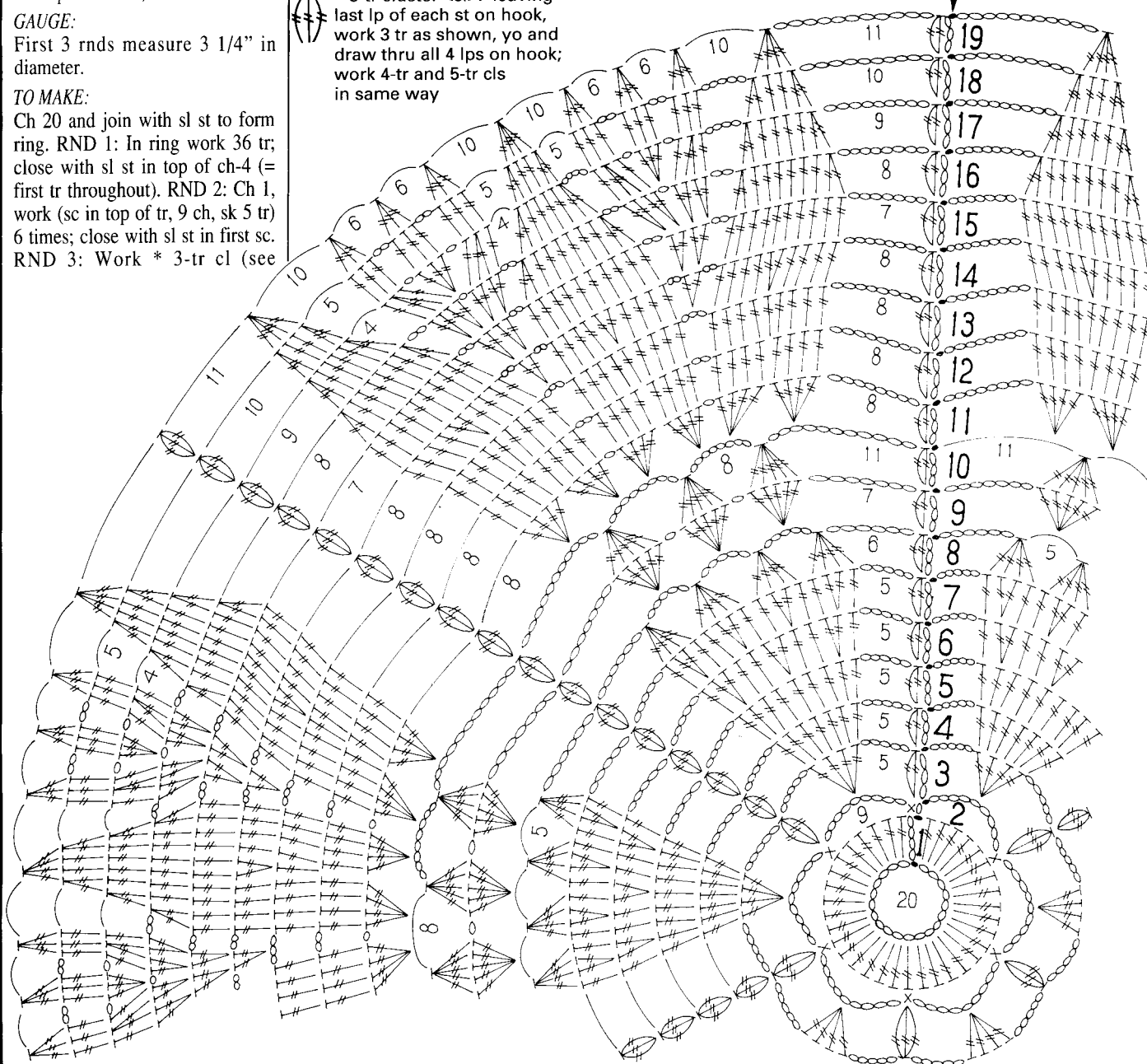

5 FLOWER WALK

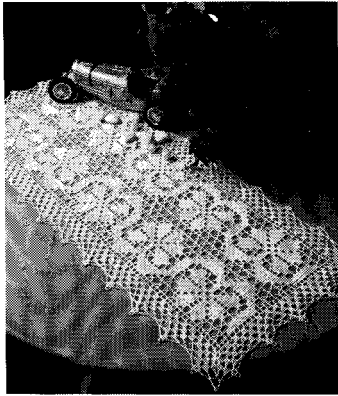

By Elizabeth Hiddleston

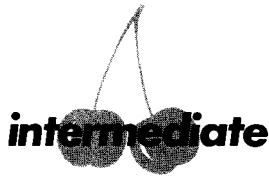

SIZE:
10 3/4" by 24 3/4", including border.

MATERIALS:
Cordonnet crochet cotton no. 20, white, about 480 yds. Steel crochet hook US size 9 or **SIZE FOR GAUGE.**

GAUGE:
15 tr and 5 rows measure 1 1/4" square. If you use fil d'Ecosse no. 10 and steel crochet hook US size 7, runner will measure about 13 1/2 by 36 1/2 inches.

TO MAKE:

First half of runner: Beg at one narrower edge, ch 91 + 9 to turn (4 ch count as first tr and 5 ch form first bar). **ROW 1:** Tr in 16th st from hook, 2 ch, sk 2 sts, tr in each of next 22 sts, 2 ch, sk 2 sts, tr in next st, work *5 ch, sk 5 sts,

tr in next st, 3 ch, sk 2 sts, sc in next st, 3 ch, sk 2 sts, tr in next st*, rep once more from * to *, 2 ch, sk 2 sts, 22 tr, 2 ch, sk 2 sts, tr in next st, 5 ch, sk 5 sts, tr in next (= last) st; ch 7, turn. **ROWS 2-44:** Beg 2nd row with sc in first bar, then work following pat diagram.

2nd half of runner: **ROWS 45-87:** Work to correspond to first half, rep rows 43 to 1. Fasten off.

Border: RS facing, attach thread with sl st in top of Tch on row 87. **RNDS 1-6:** Work all around runner as shown. At end of rnd 1, replace ch-5 lp for last corner with

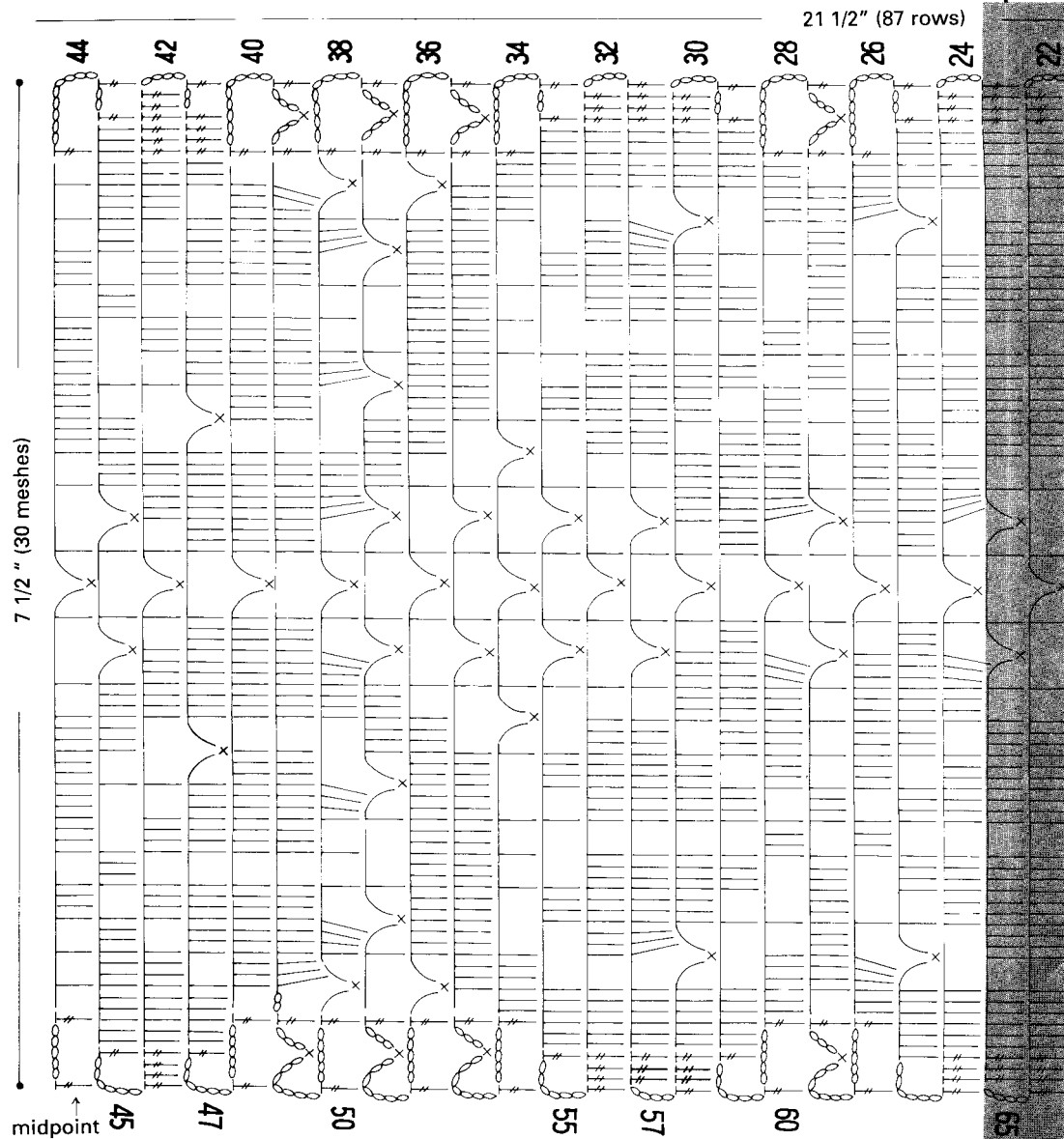

5 FLOWER WALK

2 ch + dc in top of ch-4. On rnds 2 and 3, replace last 2 ch sts with hdc, last 3 ch sts on rnd 4 with dc, and last 4 ch sts on rnd 5 with tr. On rnd 6, at corners work 10 ch, dc in 5th st of these ch-10, 4 ch, sc in ch-7 lp. Across sides, work * 6 ch, 1 shell consisting of 2 tr, 5 ch,

1 dc + 1 tr clustered (work dc in top of prev tr and work tr in same mesh as prev tr) and 1 tr all worked in same mesh, 6 ch, 2 ch-4 lps, rep from * across; close with sl st in top of closing tr below. Fasten off.

GAUGE: 1 1/4" square
= 15 tr and 5 rows

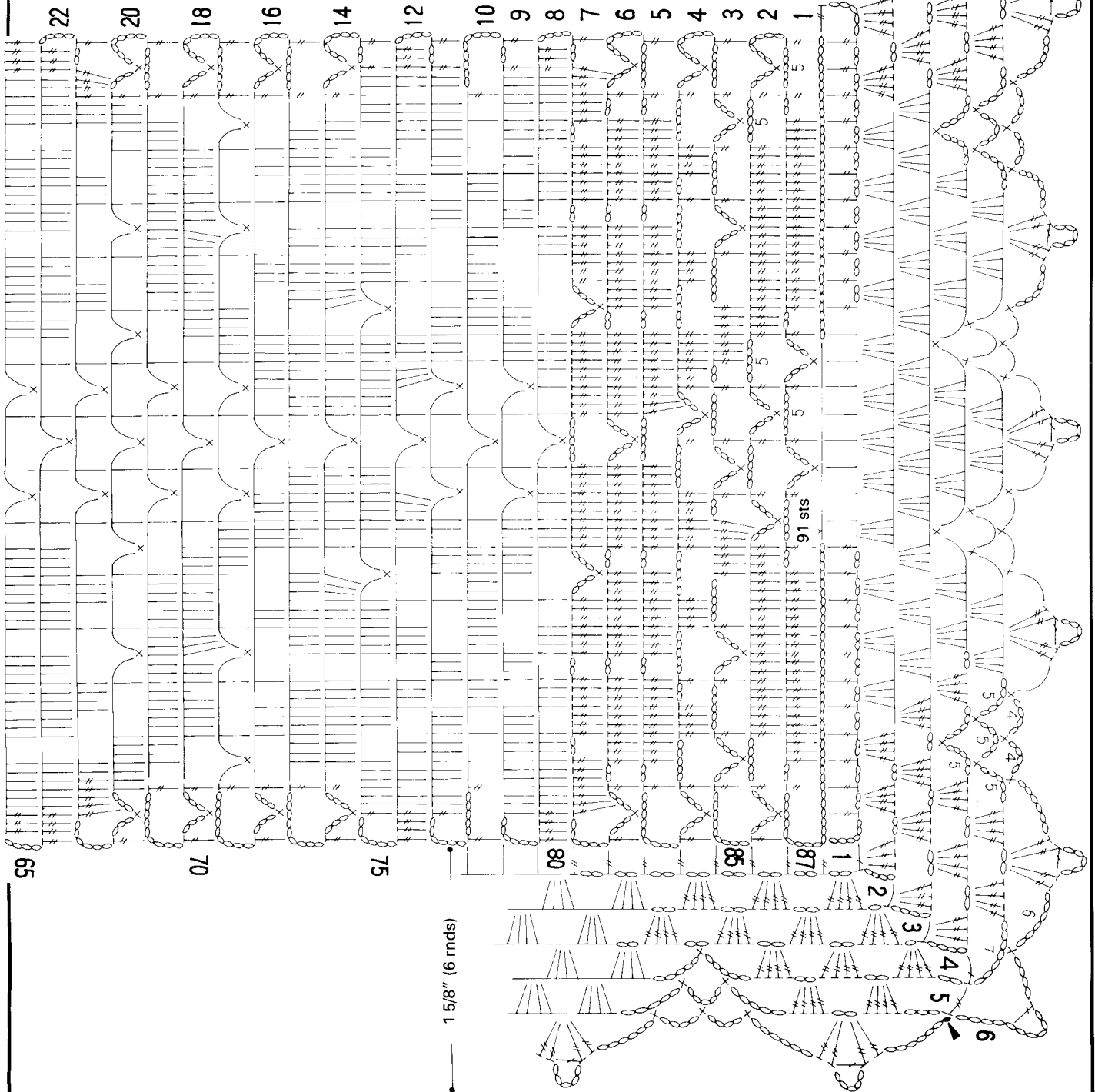

6 GOOD KITTY



By Elizabeth Hiddleson

easy to make

SIZE:
11 3/4" by 12 1/2", including edging.

MATERIALS:
Cordonnet crochet cotton no. 20, white, about 305 yds. Steel crochet hook US size 9 or **SIZE FOR GAUGE.**

GAUGE:
4" square = 15 meshes and 15 1/2 rows.

TO MAKE:
Pillowtop: Ch 136 + 6 to turn (4 ch count as first tr and 2 ch form first open mesh or om). **ROWS 1-2:** Tr in 10th st from hook, then work * 2 ch, sk 2 sts, tr in next st, rep from * across = 45 om in all; rep from * across = 45 om in all; ch 6, turn each row. **ROW 3:** 8 om, 4 solid meshes <sm> (= * 2 tr in ch-2 lp below, tr in tr, rep from * thrice more), 33 om. **ROWS 4-43:** Work following pat diagram, alternate om and sm as shown.

Edging: At end of row 43, ch 4 and, beg at left-hand edge, work 3 rnds all around pillowtop as per detail diagram; close each rnd with sl st in top of ch-4. At end of rnd 3, fasten off (see black wedge).

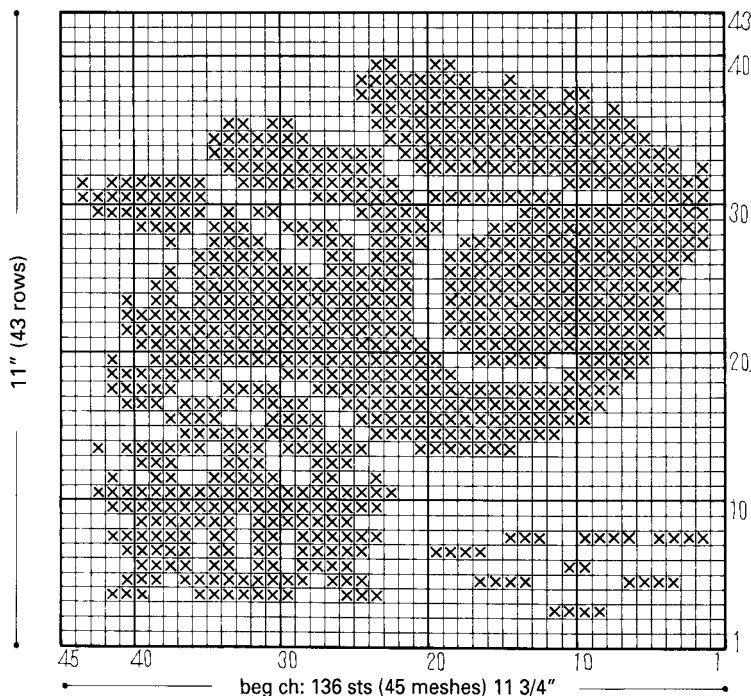
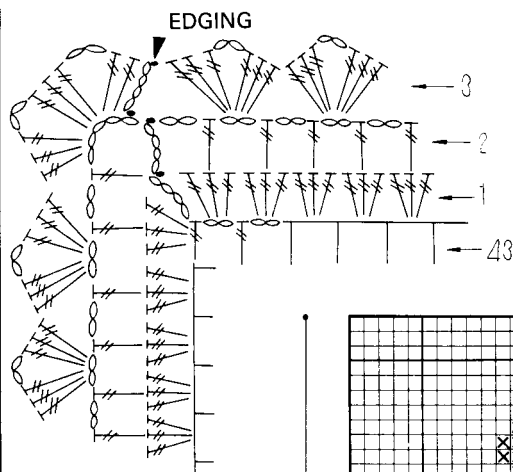

GAUGE: 4 inches square = 15 meshes x 15 1/2 rows





6



7





8 GARDENIAS

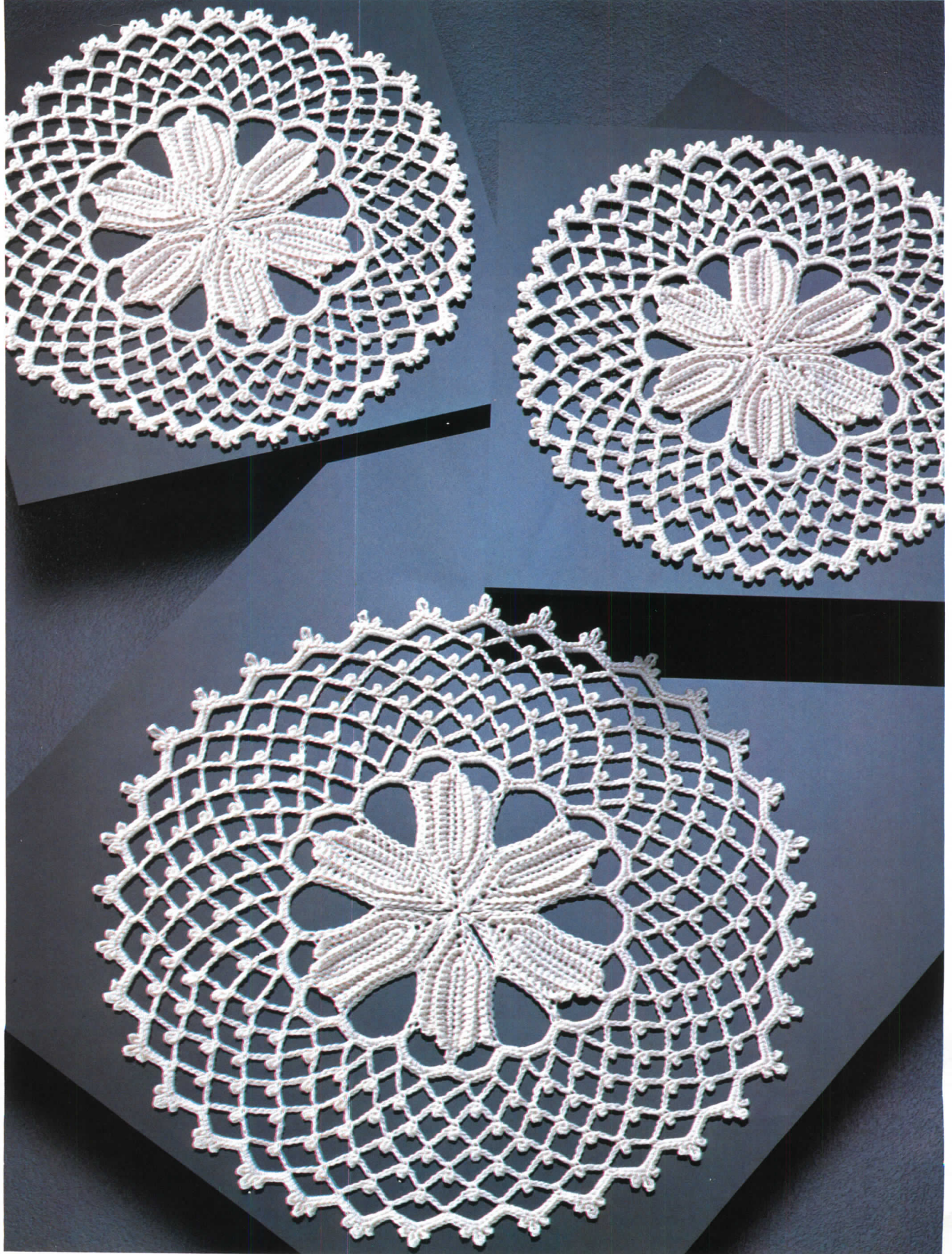

7 DELUXE BEDDING

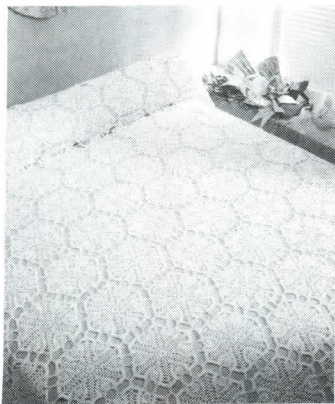

SIZE:
About 86 by 103 inches.

MATERIALS:
Shiny quality crochet cotton no. 10 (other possibilities: fil d'Ecosse no. 10 or pearl crochet cotton no. 5), white, about 10,155 yds (that is, about 1800 grams or 64 1/4 oz).

Steel crochet hook US size 7 or
SIZE FOR GAUGE.

GAUGE:
One motif is 8 1/2" across measured from one corner to opposite corner; and 7 3/8" across measured from side to opposite side. First 3 rnds of motif are 2 1/4" in diameter. **TO SAVE TIME, TAKE TIME TO CHECK GAUGE.**

NOTE:
The weight of thread may vary depending on the quality chosen. We therefore recommend completing several motifs, measuring them and weighing them. This is the only way to make absolutely sure that you will have enough thread to finish your project.

TO MAKE:

Motif (176 in all): Form loop with end of thread. **RND 1:** Ch 1, in lp work 12 sc; close with sl st in first sc. **RND 2:** Ch 4, work (sc in next st, 3 ch) 10 times, end with sc, 1 ch, hdc in first st of ch-4. **RNDS 3-11:** Work following diagram; close with sl st on each rnd and, as of rnd 5, cont with sl st to beg new rnd in first ch lp. **RND 12:** Work ** dc in first dc, 2 dc + 9 ch + 2 dc in ch-3 lp, 10 dc (that is, 1 in dc, 6 in ch lp and 1 in each of next 3 dc), 1 picot (= 7 ch, sl st in top of last dc), dc in next ch lp, 4 ch, sc + 1 picot (= 3 ch, sl st in top of sc) + sc in next ch lp, 4 ch, dc in next ch lp, 7-st picot, 9 dc (that is, 1 in each of 3 dc, 6 in ch lp), rep from ** 5 times more; close with sl st in top of ch-3 (= first dc throughout). Fasten off (see black wedge). As of 2nd motif, join thus: replace center st of ch lps and picots with sl st worked in corresp ch lp or picot of adjacent motif(s).

Motif joining: Join all 176 motifs in this way as follows: join (one 14-motif row then one 13-motif row) 6 times, end with one 14-motif row.

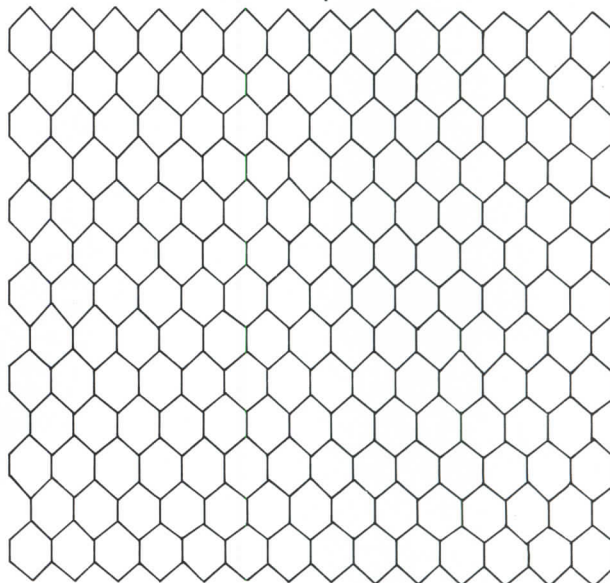

MOTIF ASSEMBLY

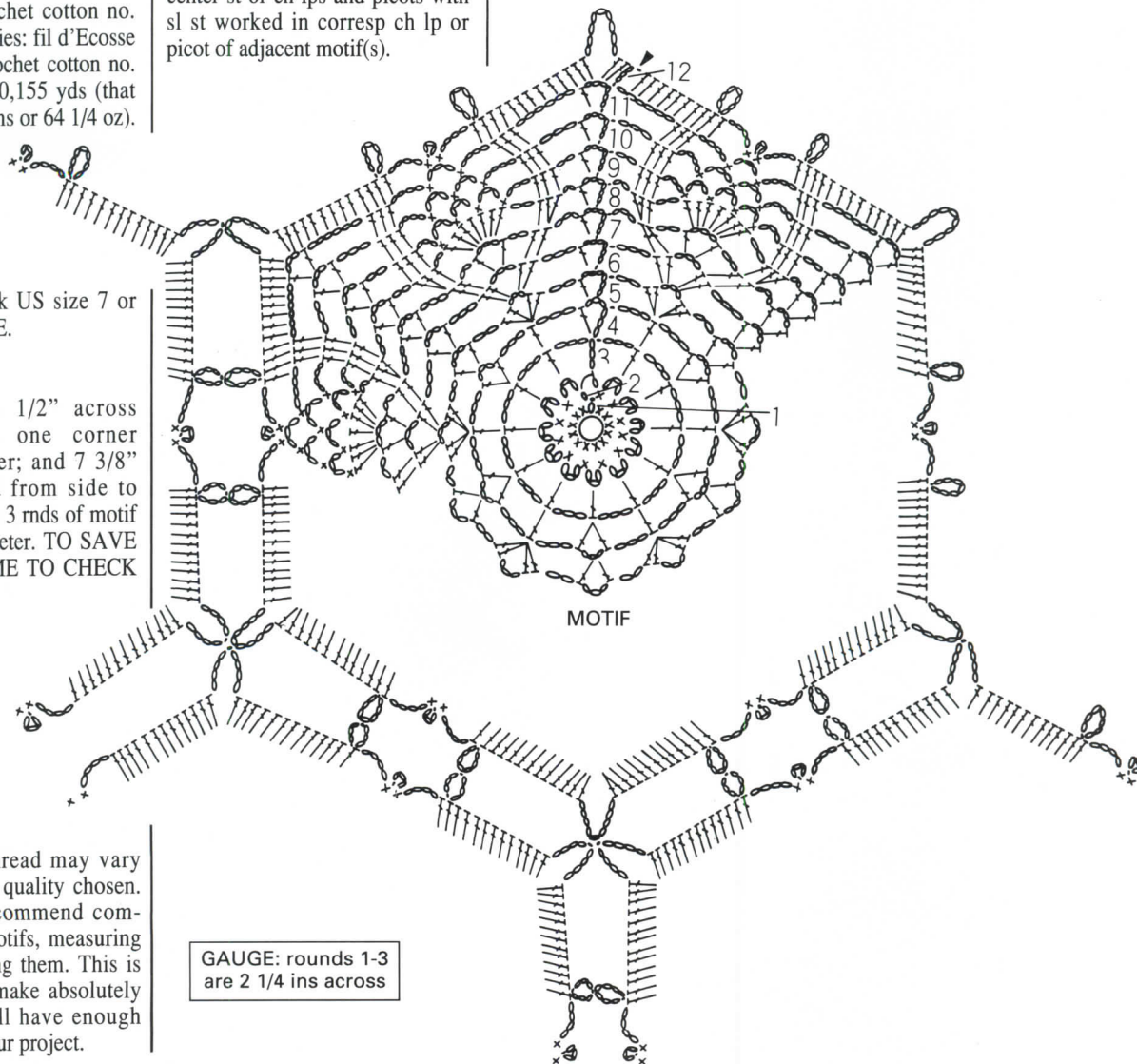

GAUGE: rounds 1-3 are 2 1/4 ins across

8 GARDENIAS

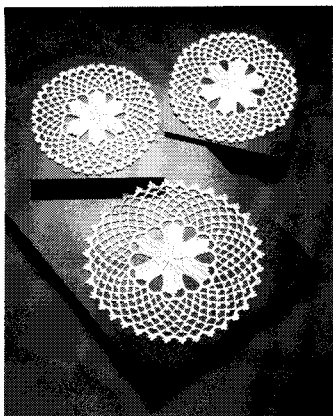

By Yoko Suzuki

SIZE:
Big mat, 8 1/4" in diameter; small mat, 6 1/4" in diameter.

MATERIALS:
For all three mats as pictured, cordonnet crochet cotton no. 20, ecru, about 260 yds. Steel crochet hook US size 9.

TO MAKE:
Big mat: For leaf, ch 15 and also refer to the project of "Anemones". On row 5, join each leaf to prev leaf with 2 sl sts as shown on diagram. Join 6th leaf to first leaf and to 5th leaf. Next, attach thread with sl st to tip of any leaf

and work 10 rnds following diagram. On rnd 1, close with sl st in first sc. On rnd 2, work 11 sc in each ch lp; close same as on rnd 1 and cont with sl st in each of next 2 sts. Work sc of rnd 3 in 4th and 8th sc of each ch lp. On rnds 3 to 8, replace last 4 ch sts on each rnd with tr worked in first sc. As of rnd 4, work 1 picot above each sc (= 3 ch, sl st in top of last sc). On last 2 rnds, close same as on rnd 1. At end of rnd 10, fasten off (see black wedge).

Small mat: For leaves, ch 13 (instead of 15). Work in same way as for Big Mat, following respective diagram. At end of rnd 8, fasten off.

sc worked in back strand only of sts on row below

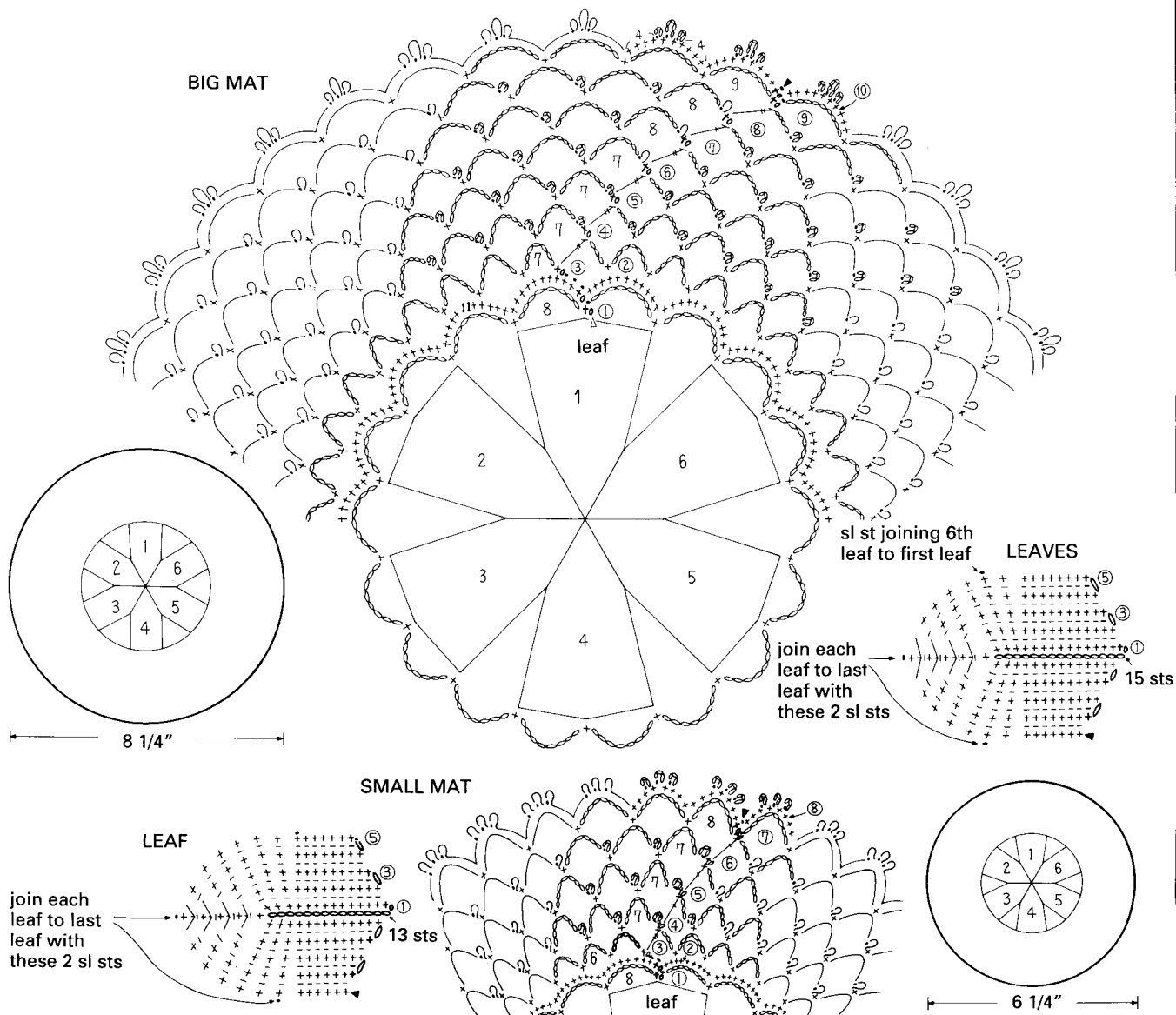
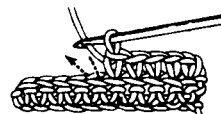

9 FOUR CORNERS

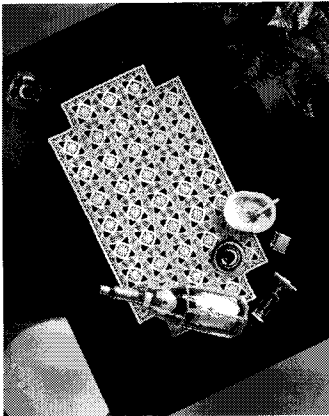

By Yoko Suzuki

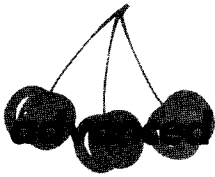

SIZE:
About 13 3/4 by 24 1/4 inches.

MATERIALS:
Cordonnet crochet cotton (or use fil d'Ecosse) no. 40, white, about 1,000 yds. Steel crochet hook US size 11.

TO MAKE:

Motif (41 in all): Ch 8 and join with sl st to form ring. RND 1-9: Work following diagram; close with sl st throughout except on rnd 3, where last 3 ch sts = dc worked in first sc. At end of rnd 9, fasten off.

Joining: As of 2nd motif, join thus: replace center st of ch-5 lps and ch-9 lps with sl st worked in corresp ch lp of adjacent motif. Join all 41 motifs in this way following assembly diagram.

Edging: After all 41 motifs are joined, RS facing attach thread with sl st in right-hand upper corner and work 2 rnds all around joined motifs. On rnd 1, dec in ingoing corners by clustering dc worked in last ch-5 lp plus 1 tr worked in joining bet 2 motifs and plus 1 dc worked in first ch-5 lp of next motif (use same cluster principle as for 2-dc cl). On rnd 2, work 2-dc cl as shown; close with sl st in top of ch-3 (= first dc) and fasten off.

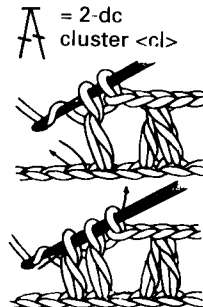
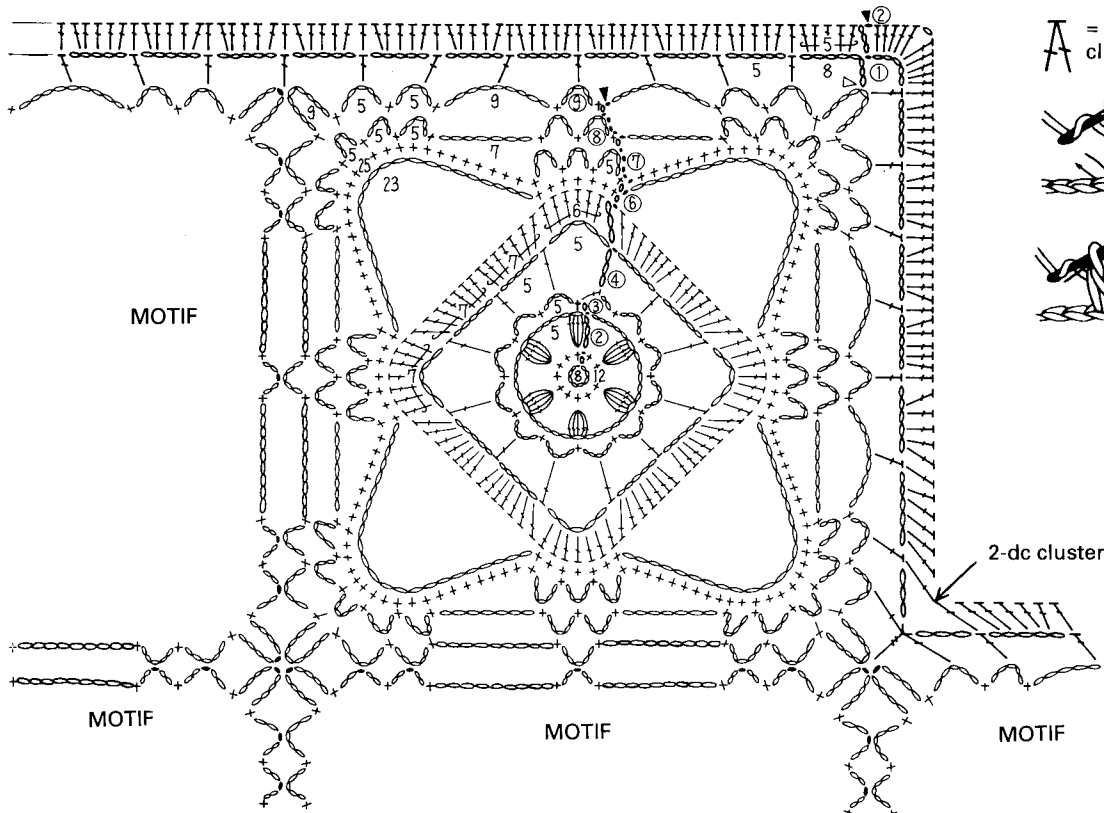
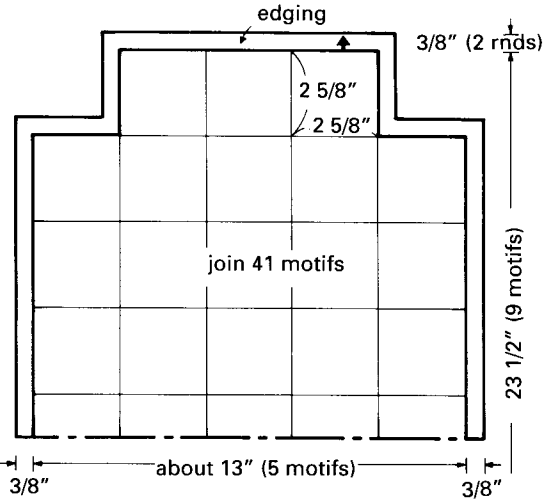
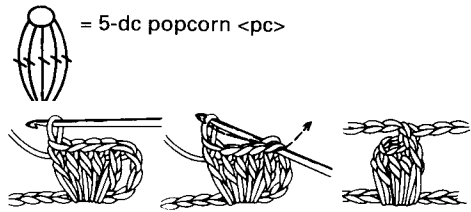

10 ACE OF CLUBS

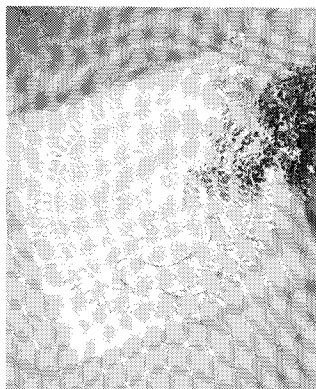

By Yoko Suzuki

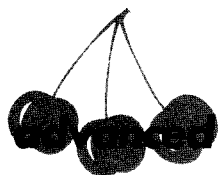

SIZE:
10 1/2" in diameter.

MATERIALS:
Cordonnet crochet cotton (or use fil d'Ecosse) no. 40, about 375 yds and small amount crochet cotton no. 10 (to be used as filler cord), both white. Steel crochet hook US size 11.

TO MAKE:
Form loop with end of thread, in beg lp work (15 ch, sl st) 3 times.
RND 1: Ch 1, in each ch-15 lp work 2 sc, 2 hdc, 16 dc, 2 hdc and 2 sc; close with sl st in first sc.
RND 2: Ch 1, inserting hook in back strand only of sts, work sc in

each st around; close same as on rnd 1, turn, work sl st in each of last 4 sts, ch 1, turn and cont RS facing. RND 3: Work * 2-sc cl (see how-to) having first sc in same st as last sl st and 2nd sc in 4th st of next leaf, then (5 ch, sk 2 sts, sc in next st) 5 times, cont with 5 ch, sk 2 sts, rep from * around; close same as on prev rnds and cont with sl st in each of next 3 sts. RND 4: In each ch lp around work sc (1 ch counts as first sc), 1 picot (= 3 ch, sl st in top of last sc) and 5 ch; last 3 ch sts on rnds 4 and 5 = dc worked in ch-1. RNDs 5-9: Work following diagram. On rnds 7 and 8, replace last 4 ch sts of 24th ch lp with tr.

RND 10: Place filler cord along md 9 and, working over filler cord and in sts on rnd 9 at the same time, work (sc in sc, 6 sc in ch lp) 24 times. Cut filler cord. RND 11: Work (2 tr, 7 ch) 24 times. RND 12: Same as rnd 10, working sc in each tr and 7 sc in each ch-7 lp. RNDs 13-25: Work following diagram = 72 ch lps in all. On rnd 24, work same as on rnd 10, having sc in each sc and 7 sc in each ch lp. RND 26: Ch 1, work sc in each of first 2 tr, then * 4 sc + picot + 3 sc in ch lp, sc in next tr, 11 ch, remove hook from lp, insert hook to the right in sc located above 2nd tr, pull dropped lp thru, work 6 sc, 3-st picot, sc, 4-st picot, sc, 3-st picot and 6 sc in ch-11 lp, sc in next tr, rep from * around; close with sl st in first sc. Fasten off.

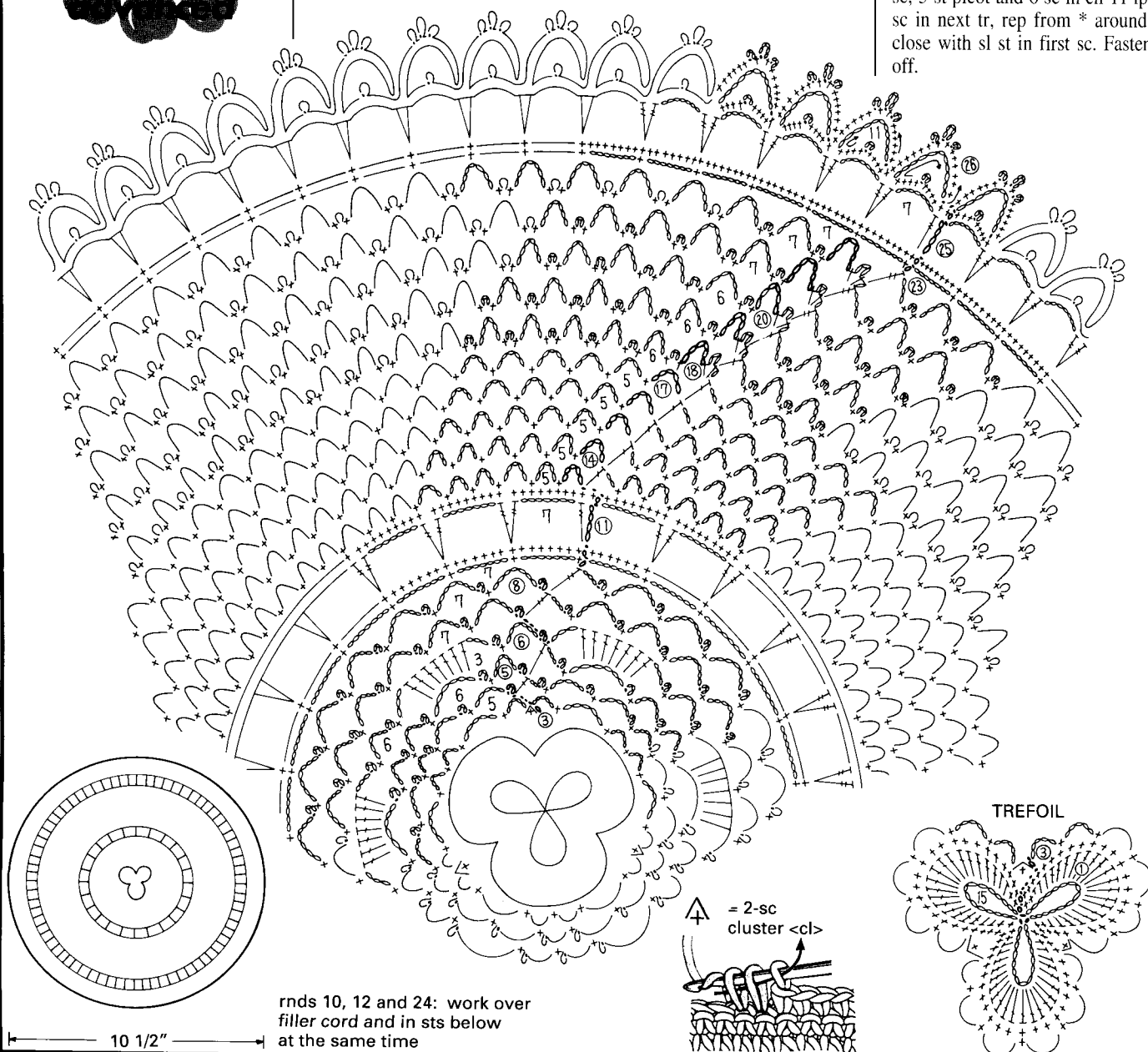

9 FOUR CORNERS



10 ACE OF CLUBS



11 FANCY FLOWER



12 HIGH TEA



11 FANCY FLOWER

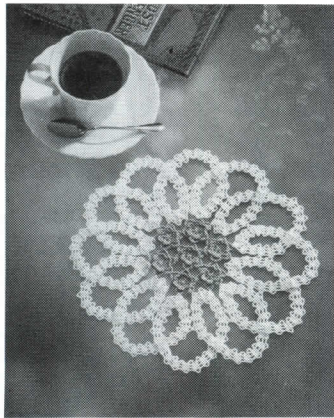

By Yoko Suzuki

MATERIALS:

Cordonnet crochet cotton (or use fil d'Écosse) no. 40, about 125 yds white and about 65 yds pink.
Steel crochet hook US size 11.

TO MAKE:

Flower motif (7 in all): Using pink, ch 5 and join with sl st to form ring, then work following diagram (also refer to directions for "Anemones"). As of 2nd motif, join on rnd 4 to center and to adjacent motif thus: before working off last 2 lps of 3rd dc, insert hook under both top strands of corresp dc of adjacent motif, yo

and draw under 2 strands of the motif being joined and thru 2 lps on hook at the same time. Join all 7 motifs in this way.

Band: With white ch 10. **ROW 1:** Dc in 5th st of ch-10 and in each of next 4 sts; ch 5, turn. **ROW 2:** Dc in first dc, * 1 ch, sk 1 st, dc in next st, rep from * once more; ch 5, turn. **ROW 3:** Dc in first dc, * dc over ch-1 lp, dc in dc, rep from * once more; ch 5, turn each row. **ROWS 4-42:** Rep rows 2 and 3 and, at end of rows 24 and 28, ch 2, work sl st in st of flower to which tiny arrow points, 2 ch, turn, then cont with dc same as on prev rows. At end of row 29, ch 2, insert hook in last 3 ch lps, work 1 sl st, 2 ch, turn and work row 30 into dc of row 29. Join end of row 41 to beg of row 13 with 1 sl st as

shown on diagram. Rep these 42 rows 11 times more, alternately joining one band loop to one flower and the next band loop to 2 flowers; also join band loops to each other at end of rows 32 and 34 as per diagram. Sew narrow ends of band tog using slip stitches.

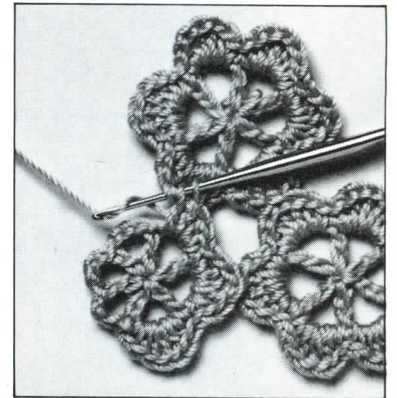
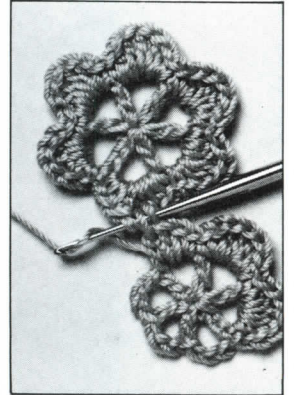

SIZE:
9 1/2" in diameter.

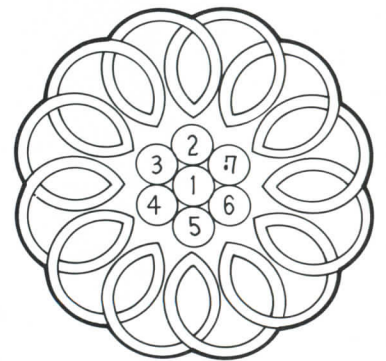
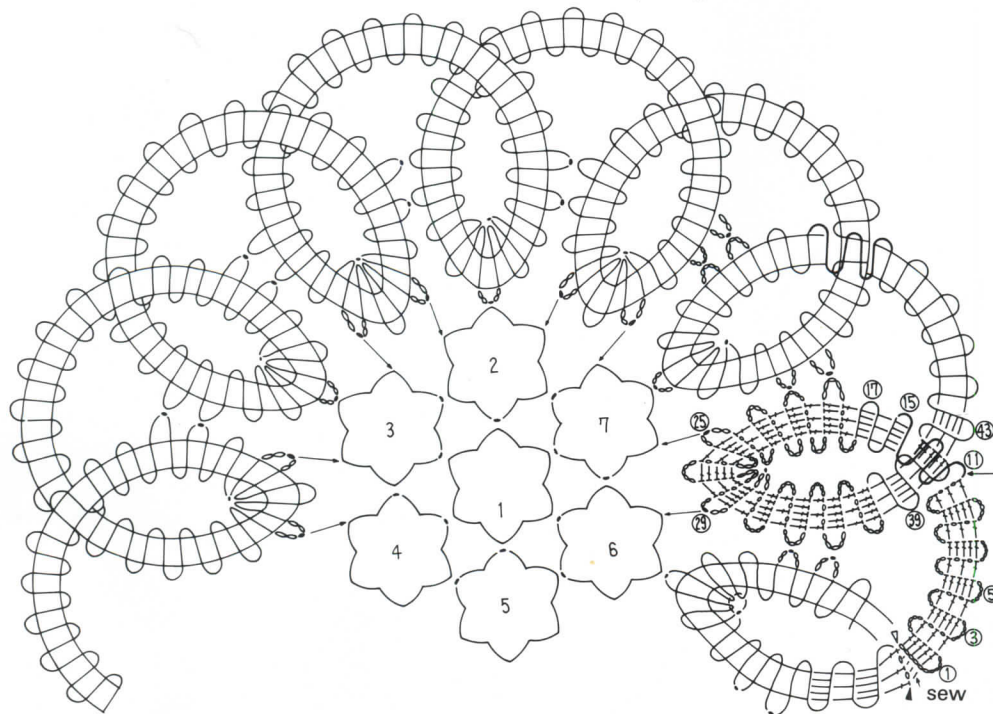
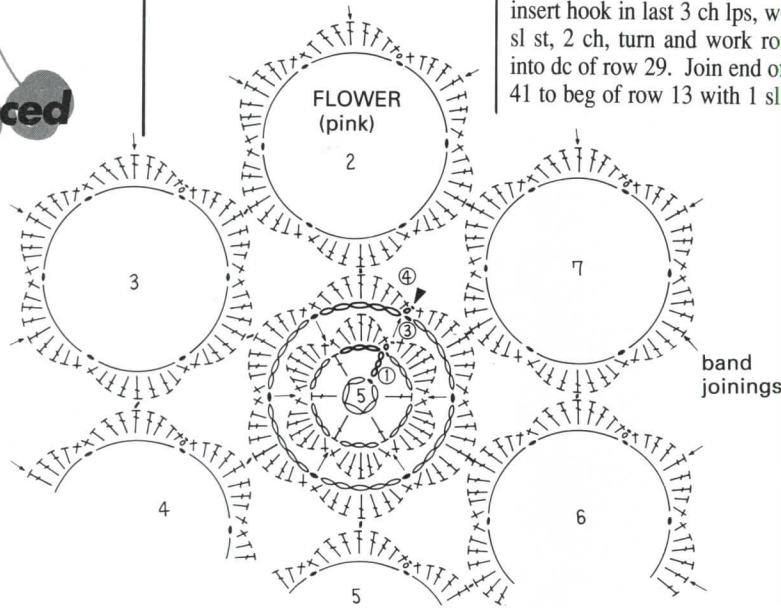

9 1/2"

work 1 sl st
in this st after
5th dc of row 41

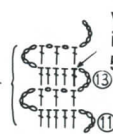

12 HIGH TEA



By Yoko Suzuki

SIZE:
43 1/2" on each side.

MATERIALS:
Shiny quality crochet cotton (or use fil d'Ecosse) no. 20, beige, about 2,835 yds. Steel crochet hook US size 9.

TO MAKE:
Tablecloth: Refer to "How to Begin" diagram. Form loop with end of thread. RND 1: In lp work (dc, 5 ch) 4 times; replace last 3 ch sts on each rnd with dc worked in top of ch-3 (= first dc throughout). RND 2: Work * 3 dc in ch lp, dc in dc, 3 dc in ch lp, 5 ch, rep from * 3 times more. RND 3: ** 3 dc in ch lp, dc in dc, * 2 ch, sk 2 sts, dc in next st, rep from * once more, 3 dc in ch lp, 5

ch, rep from * around. RNDs 4-10: Work following diagram and lacet stitch how-tos. RNDs 11-83: In corners inc same as bef, alternate meshes as per pat diagram and rep motifs to corresp on each side of center dc. For sm over om, work 2 dc in ch-2 lp below and dc in dc. Close same as on first 10 rnds throughout.

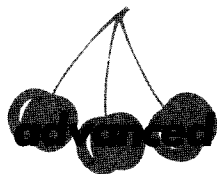

 = 2-tr cluster (cl): leaving last lp of each st on hook, work 2 tr in same sp, yo and draw thru all 3 lps on hook

HOW TO BEGIN

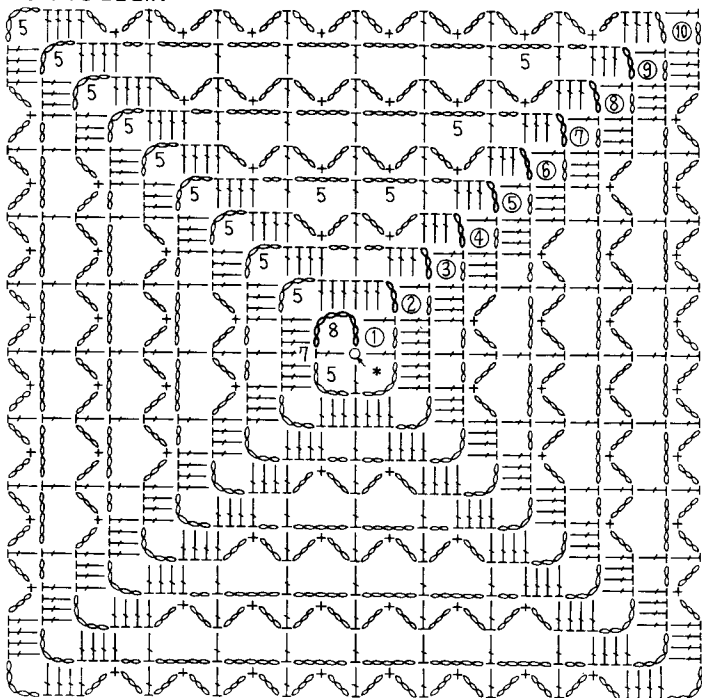

*: form ring with end of thread

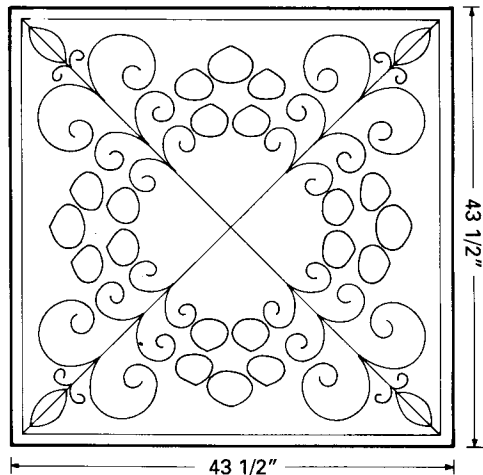

EDGING

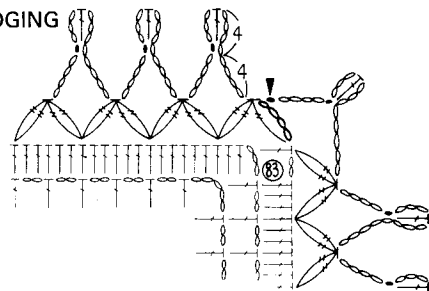

LACETS

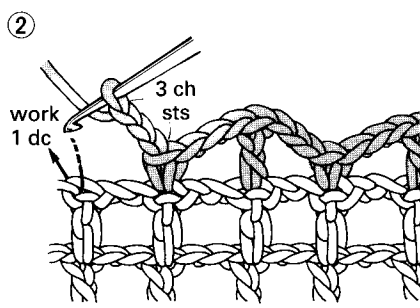
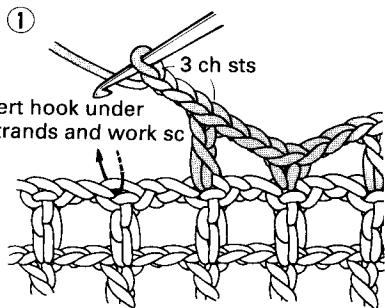

BARS

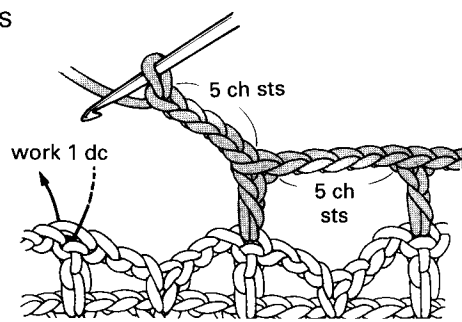

12 HIGH TEA

Edging: At end of rnd 83, ch 4 (= first tr), work 3-tr cluster distributing sts thus: first tr in top of last dc on rnd 83, sk 3 dc, work

next 2 tr in next dc, then cont with * 8 ch, dc + 3 ch + sl st in 4th st from hook, 4 ch, 4-tr cl distributing sts thus: work first 2 tr in

same st as last 2 tr, sk 5 sts, 2 tr in next st, rep from * around; close with sl st in top of first cl. Fasten off (see black wedge).

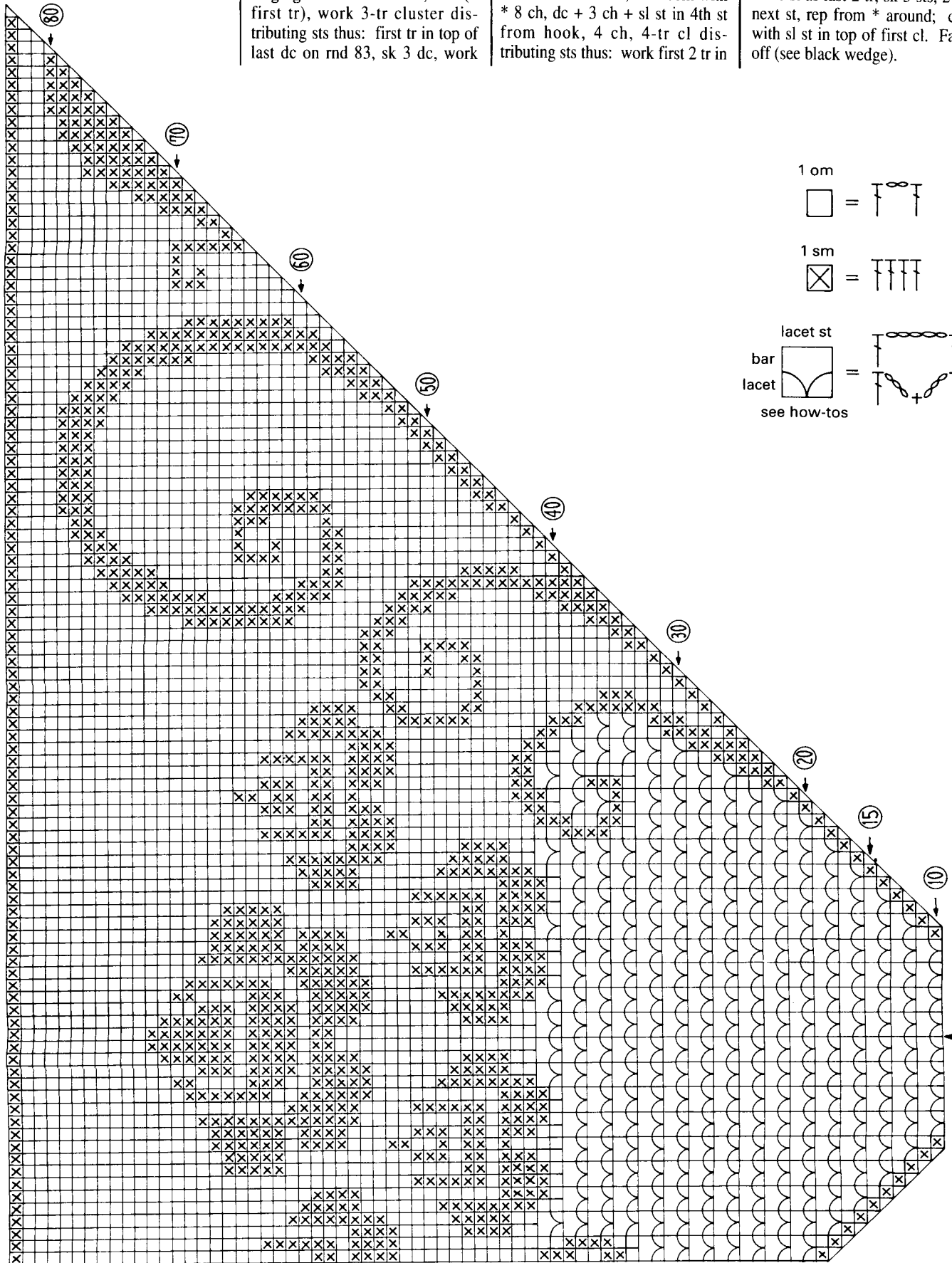

1 om

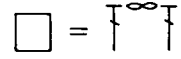

1 sm

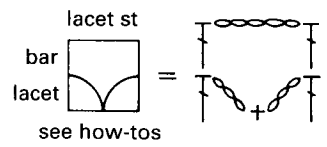
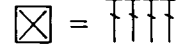

center of side

13-14 ANEMONES

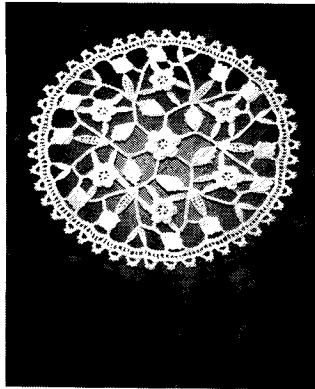

By Yoko Suzuki

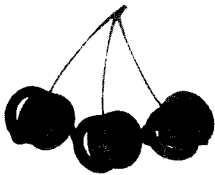

SIZE:
9 3/4" in diameter.

MATERIALS:

Fil d'Ecosse no. 40, about 250 yds white; about 65 yds each beige, lt green and lt pink; small amount each emerald green, dk pink, lilac and violet. Steel crochet hook US size 11.

TO MAKE:

Flowers: Work center flower for 6 rnds following diagram, then complete 6 small flowers same as center flower but fasten off after rnd 4.

Leaves: Complete 18 leaves A (6 big and 12 little) following diagram. Next, complete 6 leaves B, 24 leaves C and 6 leaves D.

Stems: for each of 6 stems, ch 51, beg in 2nd st from hook work 7 sc (that is, 1 sc in each st), 8 ch, sc in 2nd st from hook and in each of next 26 sts, cont with 36 ch and work following diagram.

Assembly: Arrange flowers, leaves and stems as per Assembly Diagram and sew to each other with slip stitches.

Border: RS facing, attach beige with sl st. RND 1: Insert hook for sc in tips of leaves D and A as shown on Assembly Diagram, and work * sc, 9 ch, rep from * 35 times more; close first 2 rnds with sl st in first sc. RNDs 2-3: Insert

hook for sc in sc and in ch sts, work following diagram. On rnd 3, close with sl st in 3rd st of ch-4. RND 4: Ch 1, inserting hook in dc and in ch-1 lps as shown on

diagram, work * 7 sc, 7 ch, remove hook from lp, insert hook front to back in first sc of 7-sc grp, pick up dropped lp and pull it thru, ch 1, in ch-7 lp just made work 3

sc, 3-st picot, sc, 4-st picot, sc, 3-st picot and 3 sc, cont with 3 sc worked in rnd 3, rep from * around; close same as on rnd 1. Fasten off.

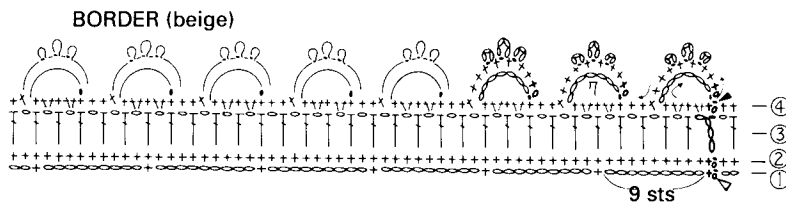
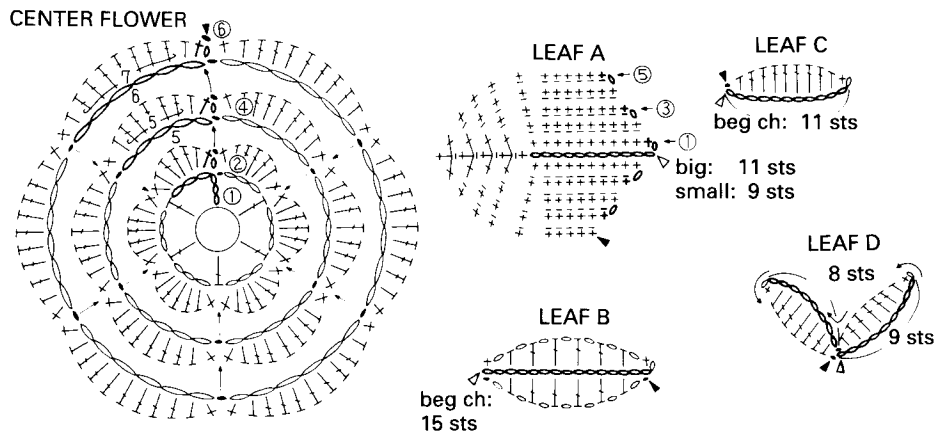

KEY TO COLORS:

center flower: rnds 1-3: dk pink; rnd 4: lt pink
flower A: rnds 1-3: dk pink; rnd 4: lt pink
flower B: rnds 1-3: lilac; rnd 4: violet
leaves A: lt green (big and small)
leaves B and D: beige
leaves C: emerald green

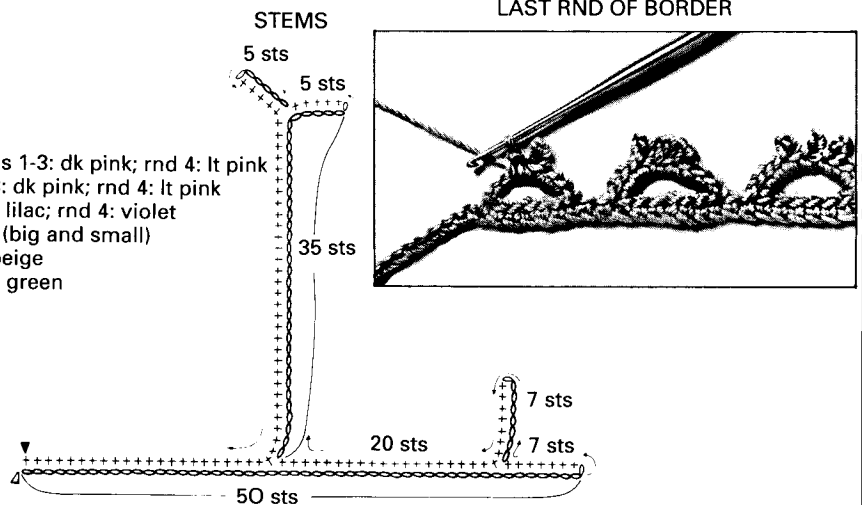

13-14 ANEMONES

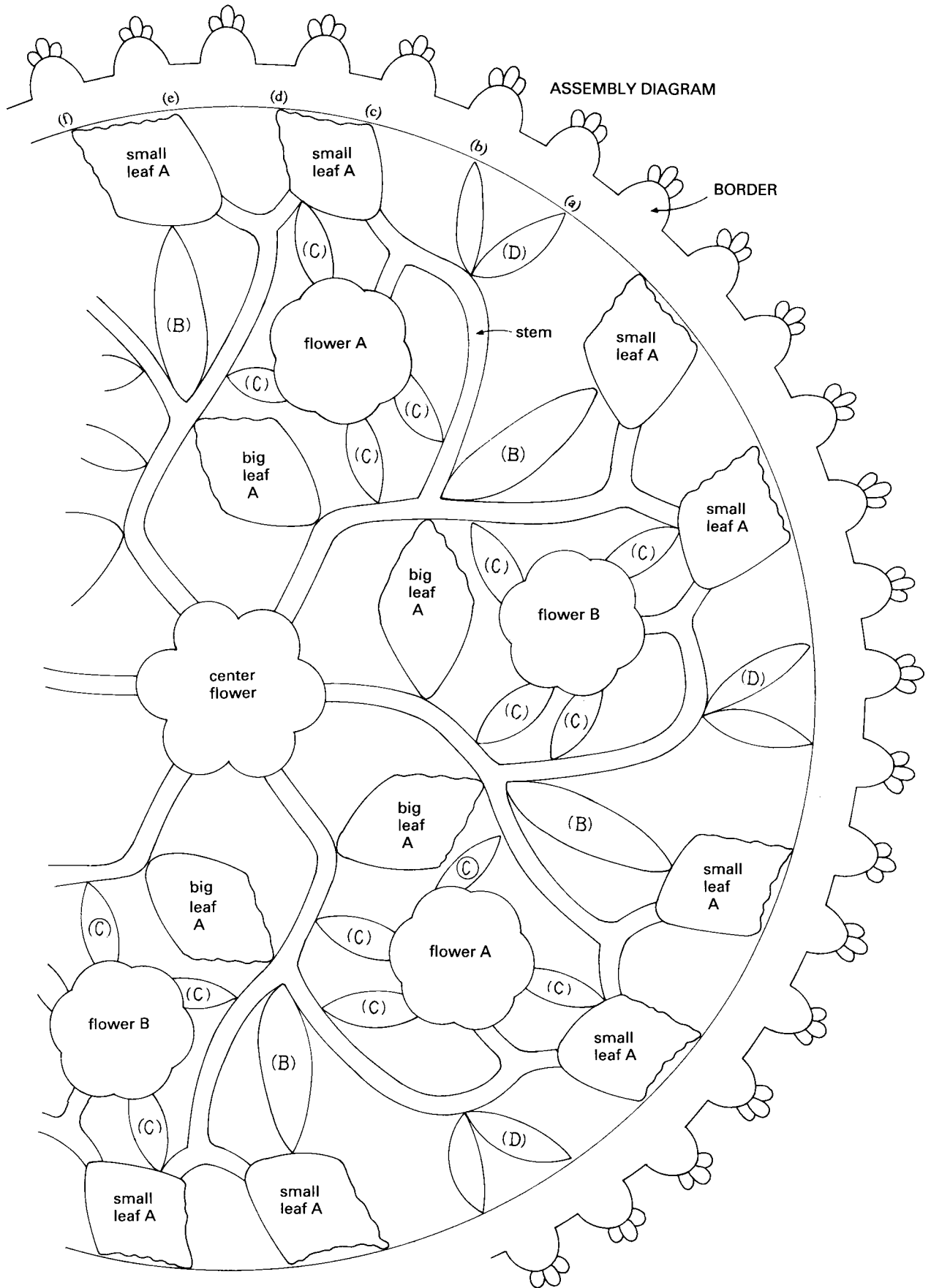

13-14 ANEMONES



13-14 ANEMONES

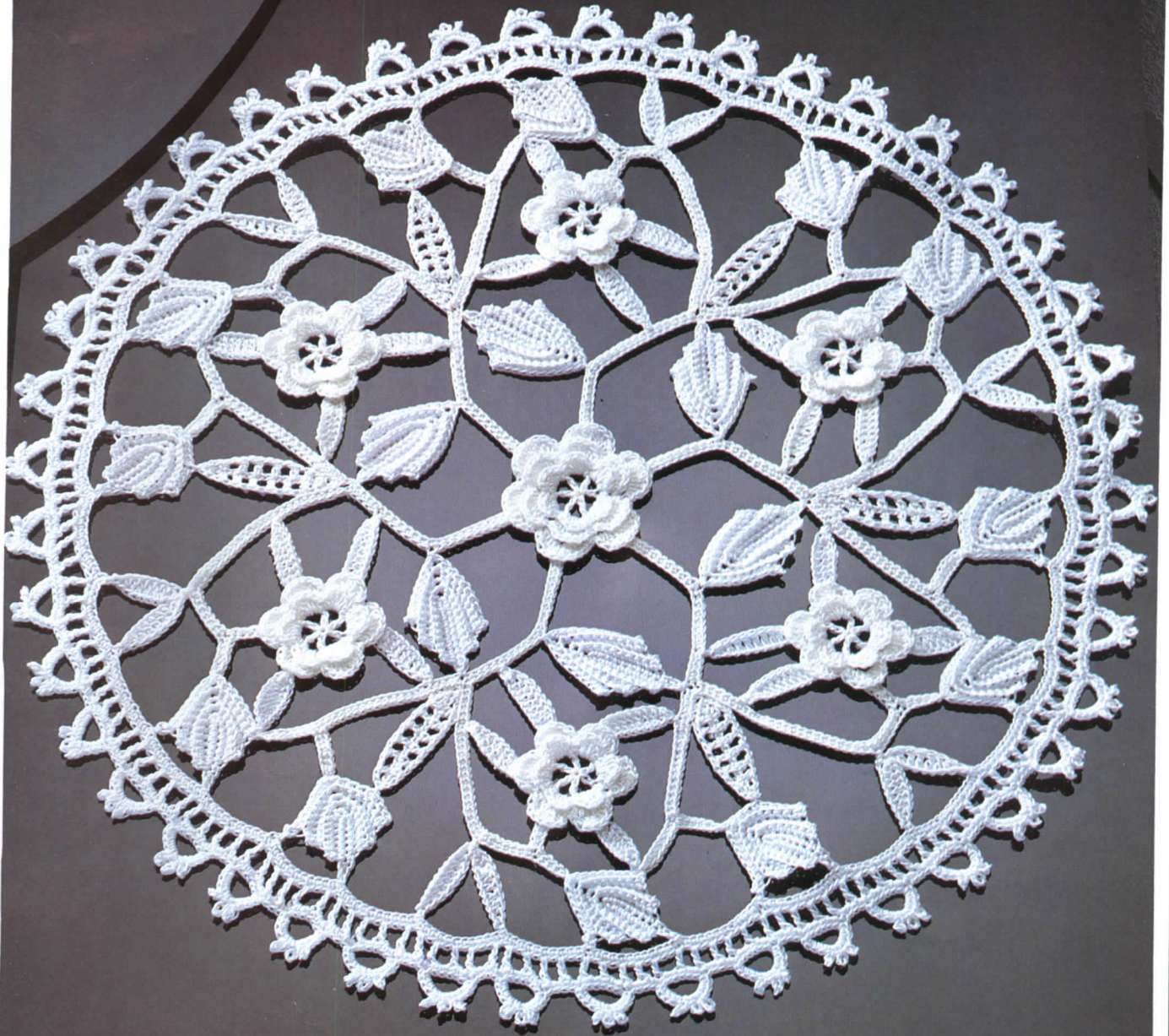

15 PEARLS



15 PEARLS

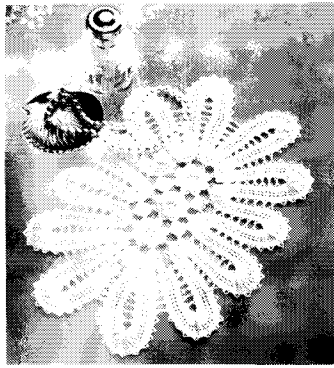

By Yoko Suzuki

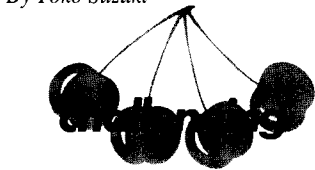

SIZE:
11 3/4 by 15 1/4 inches.

MATERIALS:

Cordonnet crochet cotton (or use fil d'Ecosse) no. 40, white, about 500 yds. Steel crochet hook US size 11.

TO MAKE:

Band: Ch 14, work dc in 6th st from hook and work dc and ch sts back and forth in rows following diagram; ch 5, turn each row (= Tch). Up to row 16 work even. At end of row 16, work Tch thus: 2 ch, insert hook in 5 last Tch and work sl st, 2 ch, turn. Cont same as for prev rows, but at end of rows 18, 20 and 22, join Tch to opposite Tch thus: 2 ch, sl st in corresp Tch, 2 ch, turn. Work even up to row 26. On row 27, inc as shown, work even up to row 41. Now work 2 ch, sl st in last 7 Tch, 2 ch, turn and cont with row 42.

On row 43, dec as shown, then join Tch with sl st or with dc using diagram of Completed Work as your guide (the line at which bold-type arrow starts marks the beg ch). After completing band, sew narrow ends tog with slip stitches.

Flowers (3 in all): Work following diagram (also refer to directions for "Anemones"). On rnd 6, join flowers to ch lps and to each other thus: before working off last 2 lps on hook of st marked on diagram as "joining stitch," insert hook in corresp ch lp or under 2 strands of corresp st, yo and draw thru ch lp (or 2 strands of st to be joined) plus 2 lps on hook.

Leaves (4 in all): Work following diagram (directions for "Anemones" will also be helpful). On first and 5th rows, join corresp sts in same way as you joined flowers.

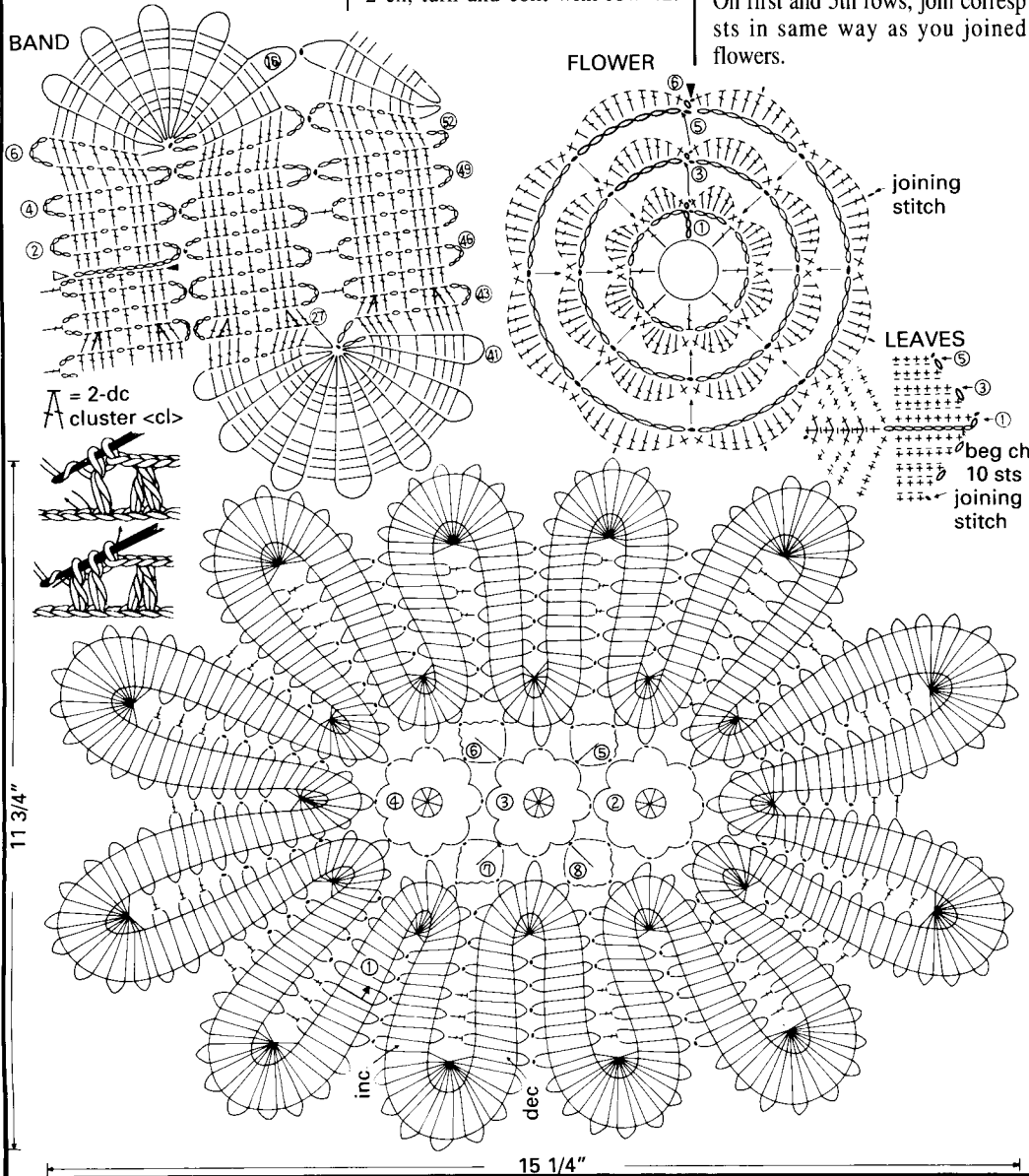

16 TENDRILS

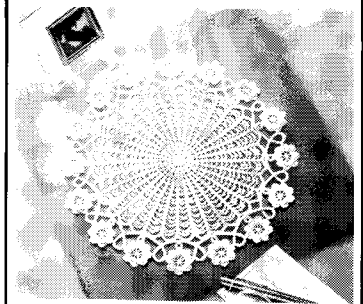

By Yoko Suzuki

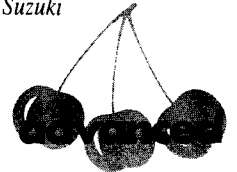

SIZE:
About 10 1/2" in diameter.

MATERIALS:

Cordonnet crochet cotton (or use fil d'Ecosse) no. 40, about 115 yds, and small amount crochet cotton no. 10 (to use as filler cord), both white. Steel crochet hook US size 11.

TO MAKE:

Mat: Form loop with end of thread. RND 1: Ch 3 and work 15 dc in beg lp; up to rnd 1, close each rnd with sl st in top of ch-3 (= first dc throughout). RNDs 2-7: Work dc in dc and ch sts following diagram. RND 8: Work * 2 dc, 1 ch, 1 picot (= 3 ch and sl st in 4th st from hook), 1 ch, rep from * 31 times more. RNDs 9-18: Work following diagram. RND 19: Ch 1, work * sc in each dc, 11 sc in ch-11 lp, rep from * around; close with sl st in first sc and fasten off (see black wedge).

Tendrils: Ch 1, pick up filler cord, work * sc over filler cord and into 6th sc of ch-11 lp on rnd 19 (insert hook under both top strands of this sc) at the same time, cont working over filler cord with 5 sc, 31 sc for big tendril loop (see Photo 3), 5 sc over filler cord, 1 sc joining to center st of next ch lp on 19th rnd, 5 sc over filler cord, 15 sc for small tendril loop (see Photo 4), 5 sc over filler cord, rep from * all around.

Flowers (16 in all): Form loop with end of thread and work 4 rnds following diagram. For sc on rnd 3, insert hook on WS under 2 vertical strands of first sc of each petal. On rnd 4, join each flower to tendrils thus: before working center dc of petal to be joined, insert hook under 2 strands of corresp sc of tendril loop.

16

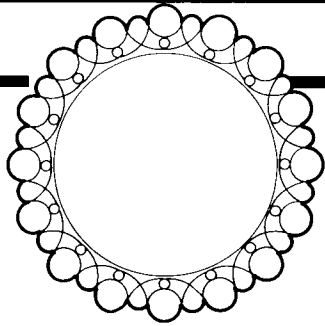

10 1/2"

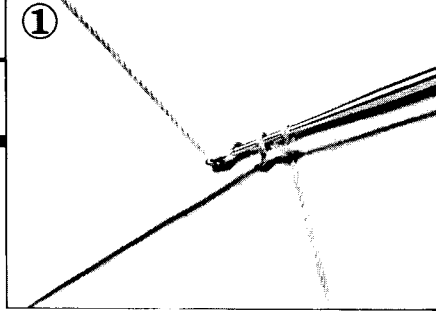

1- Begin with ch 1, place end of thread back of filler cord, pull up lp and yo: you are now ready to work off 2 lps on hook of first sc.

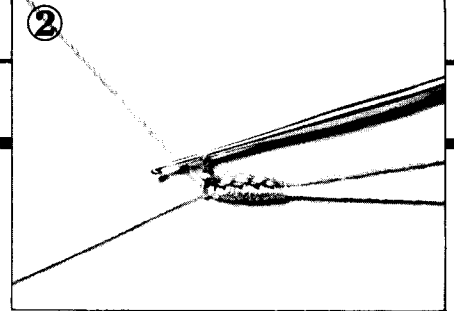

2- Work next sc in same way by inserting hook under filler cord, then complete number of sc shown on diagram.

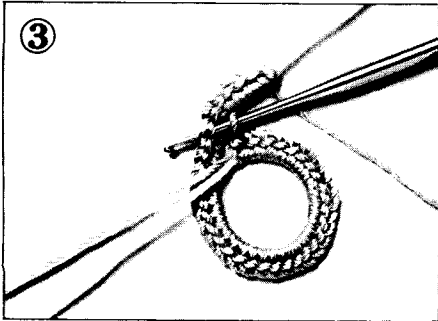

3- Before working 31st sc of big tendril loops, insert hook under 2 strands of 30th sc just made leaving the 2 threads in front, then work 31st sc over filler cord (= 1 sc with sl st).

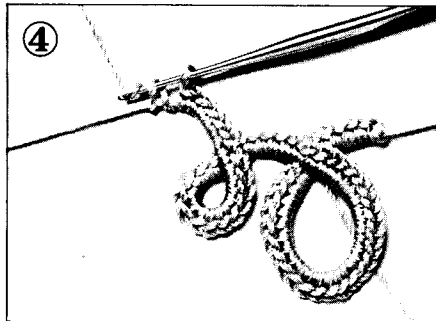

4- Shape small tendril loops thus: before working 15th sc, insert hook under 2 strands of 14th sc just made, then proceed same as for big loops.

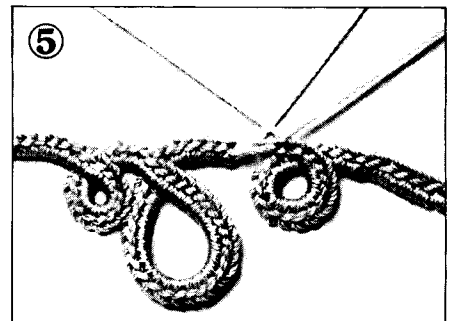

5- For closing tendril rnd to form circle, join last st to first st with hand-sewing needle thus: pass threaded needle under 2 strands of first st, then insert it downward in center of last st. Secure and conceal thread on WS.

join 16 flowers

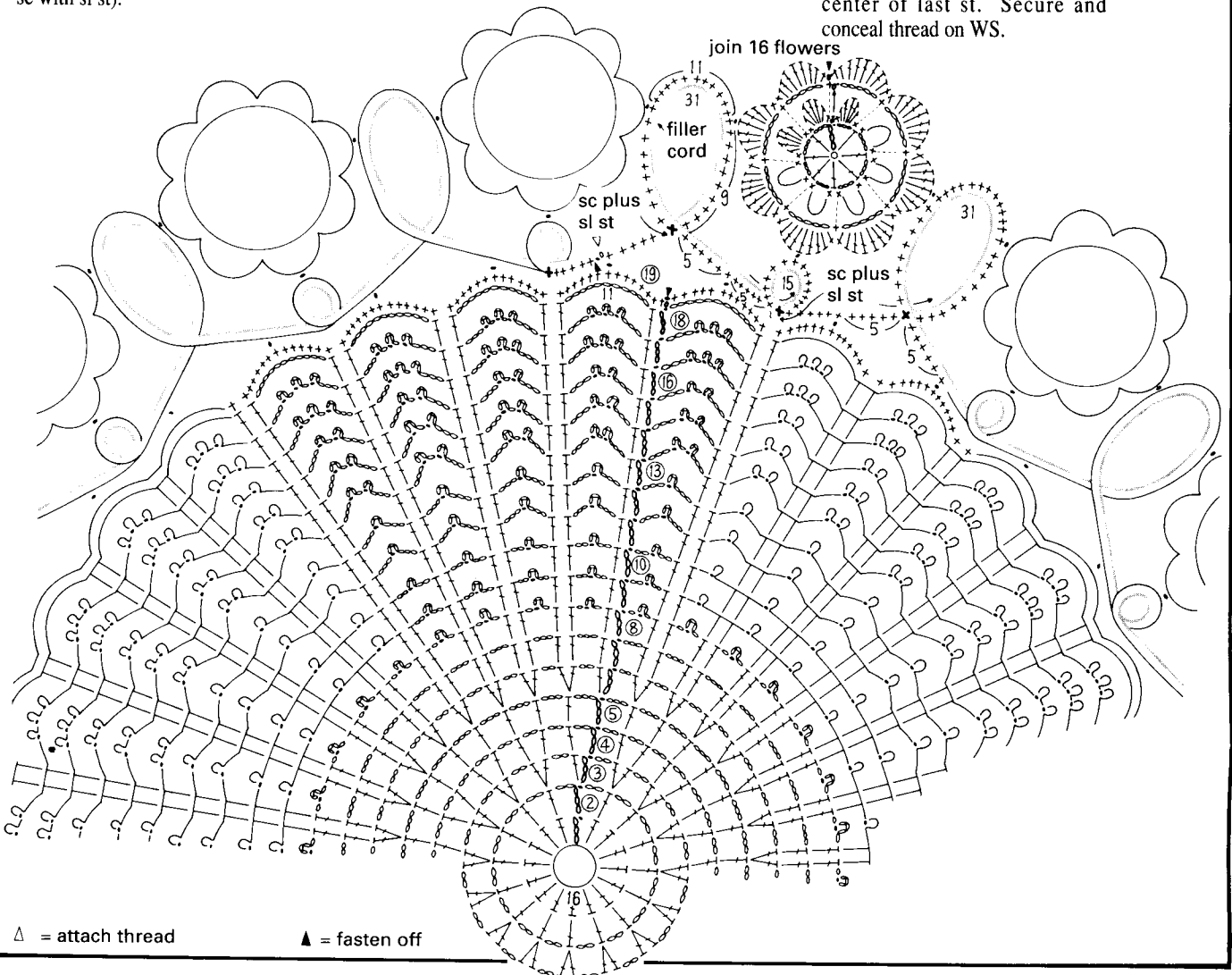

△ = attach thread

▲ = fasten off

17-18 LEAFAGE

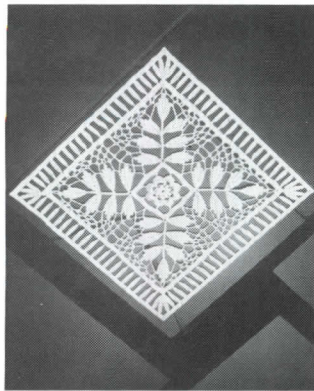

By Yoko Suzuki



SIZE:
9 3/4" square.

MATERIALS:

Crochet cotton (or use fil d'Ecosse) no. 40, about 315 yds for white mat. For multicolor mat: about 215 yds white, about 75 yds green plus small amount each violet, mauve and yellow. Steel crochet hook US size 11.

TO MAKE:

Leaves (28 in all): With green ch 13 + 1 to turn. ROW 1: Sc in 2nd st from hook and in each of next 12 sts; ch 1, turn. ROW 2: Inserting hook in back strand only of sts below, work sc in each of 13 sc, 5 sc in ch-1 at end, cont on other side of beg ch with sc in each of 10 next sts. ROWS 3-5: Cont in same way as on row 2, work 5 sc in 3rd st of 5-sc grp at leaf base on each row and sk 3 sts at end of each row. At end of row 5, fasten off.

Flower: Using yellow, ch 10 and close with sl st to form ring, then work 10 rnds following diagram, pc how-to and color key. Last 2 ch sts on rnd 2 = hdc in top of first pc. Close all other rnds with sl st in first sc or in top of ch-3 (at end of rnd 7). On rnd 5, work sc on WS of petals, inserting hook in one vertical strand on each side of sc on rnd 3. On rnd 8, work sc in each dc, 15 sc in side ch lps and 13 in corner ch lps. On next 2 rnds, insert hook in back strand only of sts below. On rnd 10, work stems by joining leaves with sl st and working sc of stems over

ch-9 and ch-10 lps. At end of rnd 10, fasten off. RNDs 11-12: Attach white with sl st as per

white wedge and work 2 rnds around leaves. On rnd 11, ch 9 at tip of corner leaf; replace last 5 ch

sts with double triple crochet (= yo 3 times, pull up lp in st, yo and draw thru lps on hook 2 by 2). RNDs 13-15: Complete sides as shown on diagram. Fasten off (see black wedge).

Border: Attach white with sl st. RND 1: Work **sc in corner sc, 9 sc in ch-7 lp, sc in each of 2 dc, 2 sc in next ch lp, work *5 sc in next ch lp, sc in each of 2 dc,* twice, 2 sc in next ch lp, rep from * to * twice, sc in next ch lp, 5 sc in next ch lp, 1 sc in each of 2 dc**, 5 sc in next ch lp, rep from ** to ** in

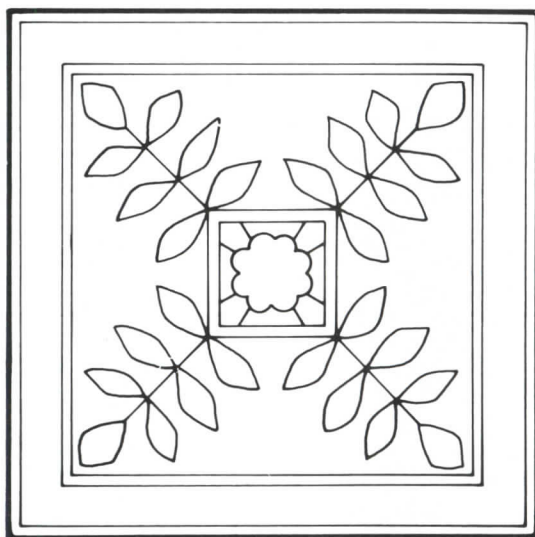

9 3/4"

9 3/4"

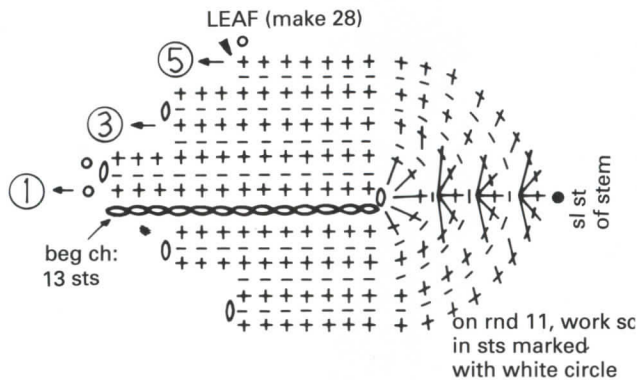

= 5-dc popcorn <pc>

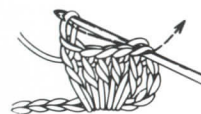
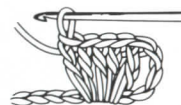

17-18 LEAFAGE

reverse order = 109 sc in all; ch 2, rep same work across each side; replace last ch st of first 2 rnds with sc worked in first sc. RND 2-3: Work sc + 2 ch, + sc in corner ch lp, sc in back strand only

of each sc. RND 4: * Work * 11 ch, sl st in corner ch lp, turn, in ch-11 just made work sc, hdc, 7 dc, hdc and sc, 3 ch (at corner ch 5

instead of 3), repeat from * around skipping 4 sts twice, 5 sts 7 times, 4 sts twice, 5 sts 7 times, 4 sts twice and joining 4 leaves to

corner ch lp. Lastly, work 3 rnds sc as shown on diagram. At end of 7th rnd of border, fasten off (see black wedge).

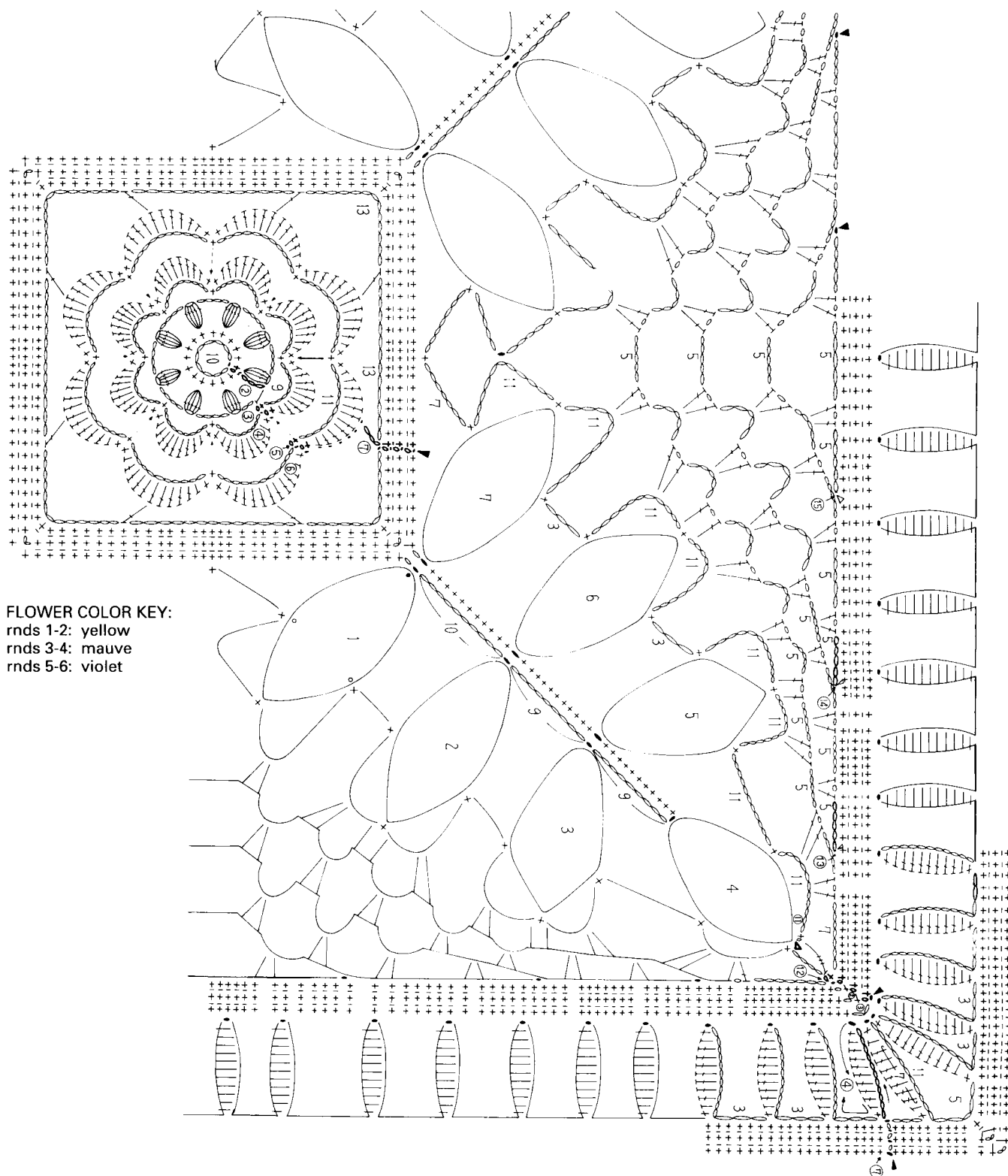

FLOWER COLOR KEY:
 rnds 1-2: yellow
 rnds 3-4: mauve
 rnds 5-6: violet

16 TENDRILS



17-18 LEAFAGE

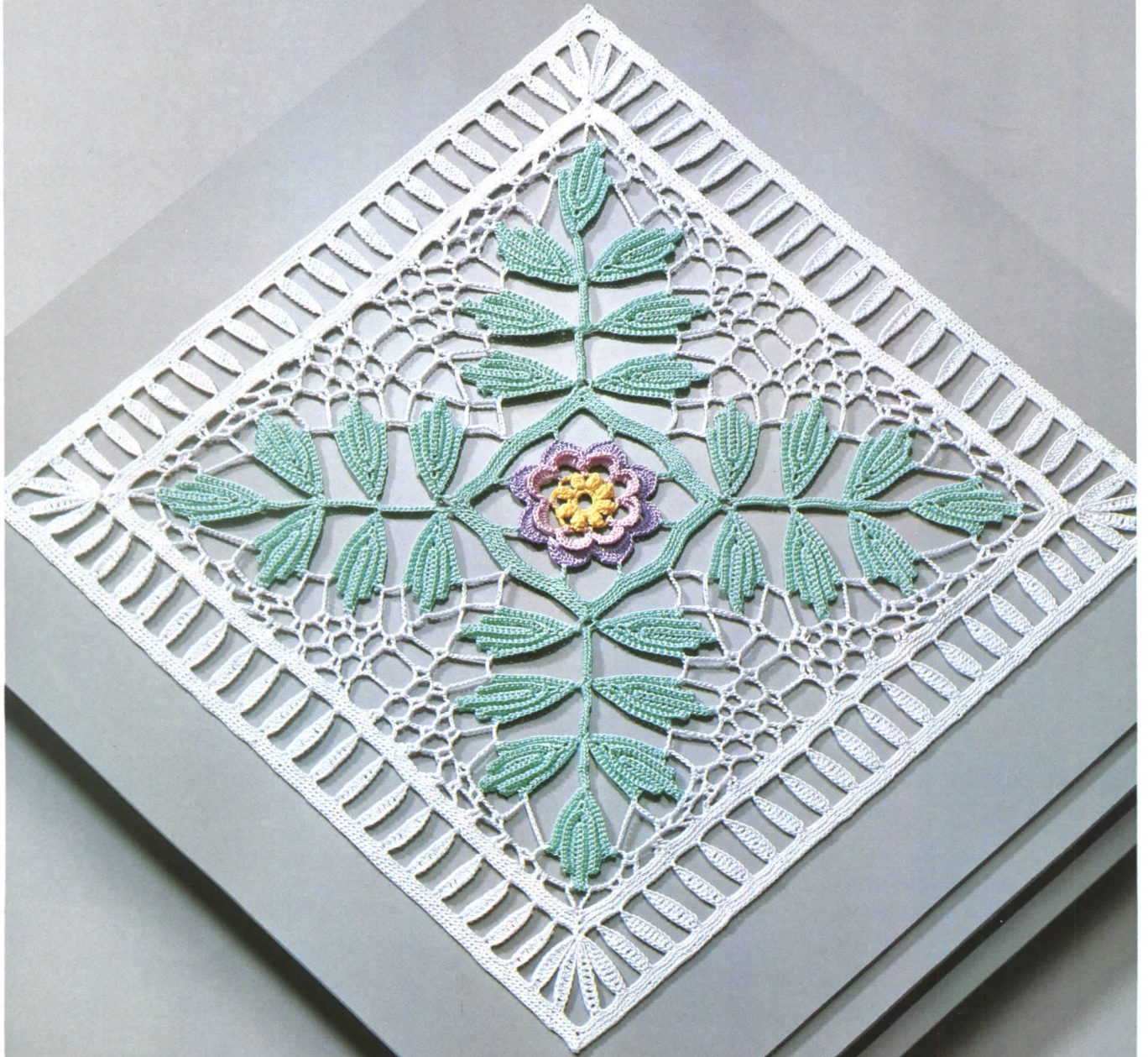

17-18 LEAFAGE



19 GOLDEN GLITTER



By Yoko Suzuki



SIZE:
22 by about 42 inches.

MATERIALS:
Cordonnet crochet cotton no. 40, white, about 1,870 yds. Metallic gold thread, about 20 grams or 3/4 oz. Steel crochet hook US size 11.

TO MAKE:
Motif: Using white, ch 10 and join with sl st to form ring. **RNDS 1-5:** Work following diagram; on rnds 1-3, close with sl st in first sc, in top of ch-3 (= first dc) or in top of ch-4 (= first tr throughout). On rnd 4, replace last 3 ch sts with dc in top of ch-4. Beg rnd 5 with 16 ch, work 1 double triple crochet <dtc> (= yo 3 times, pull up lp in st, yo and draw thru lps on hook 2 by 2 three times in all) in 4th st of ch-16 (= first "Y" made); for tips of petals, work 5-triple triple crochet <trtr> cluster <cl> thus: ** yo 4 times, pull up lp in st, * yo and draw thru 2 lps on hook, rep from * 3 times more, rep from ** once in each of next 4 sts, yo and draw thru all 6 lps on hook; for each side "Y" work thus: trtr in ch lp, 5 ch, tr in 2nd cross strand from bottom of last trtr; for each corner "Y" work thus: 1 quintuple triple crochet <quint tr> (= yo 6 times, pull up lp in st, yo and draw thru lps on hook 2 by 2), 7 ch and dtc in 3rd cross strand from bottom of last quint tr; close with sl st in 9th st of ch-16. Cut thread (see black wedge) = **motif center** made. Now complete 8 white **flowers** following diagram, on rnd 3 join each with sl st to side ch lps of motif center and to adjacent flower(s). Next, use gold thread and complete 4 **grps of 3 leaves** each as shown, joining with sl sts thus: leaf (a) to ch lp of left-hand flower and to corner of motif center; leaf (b) to base of leaf (a) and to ch lp of right-hand flower; leaf (c) to sides and base of adjacent leaves. Lastly, RS facing, attach white thread with sl st as per white wedge and work 6 mds **edging** all around following diagram; up to rnd 5, replace last 4

19 GOLDEN GLITTER

ch sts with tr worked in first sc (at end of rnd 1) or in top of ch-3 counting as first dc (at end of next rnds). On rnd 6, close with sl st in top of ch-3 and cut thread (see black wedge) = motif made. As of

2nd motif, join on rnd 6 of edging thus: replace center st of ch lps with sl st worked in corresp ch lp of adjacent motif(s). Join all 10 motifs in this way. Refer to detail

diagram showing how to join corners bet each 4 motifs.

Border: RS of joined motifs facing, attach thread with sl st in outer corner of any corner motif (see white wedge). RND 1-21: Work following diagram and detail showing border corner. On rnd 21, work thus: * 7 sc (that is,

1 in top of dc, 6 in ch lp), 11 ch, remove hook from lp, insert hook in 7th sc counting backwards, pull dropped lp thru, turn, in ch-11 just made work 6 sc, 3 picots as shown and 6 sc, rep from * all around; close with sl st. Fasten off (see black wedge).

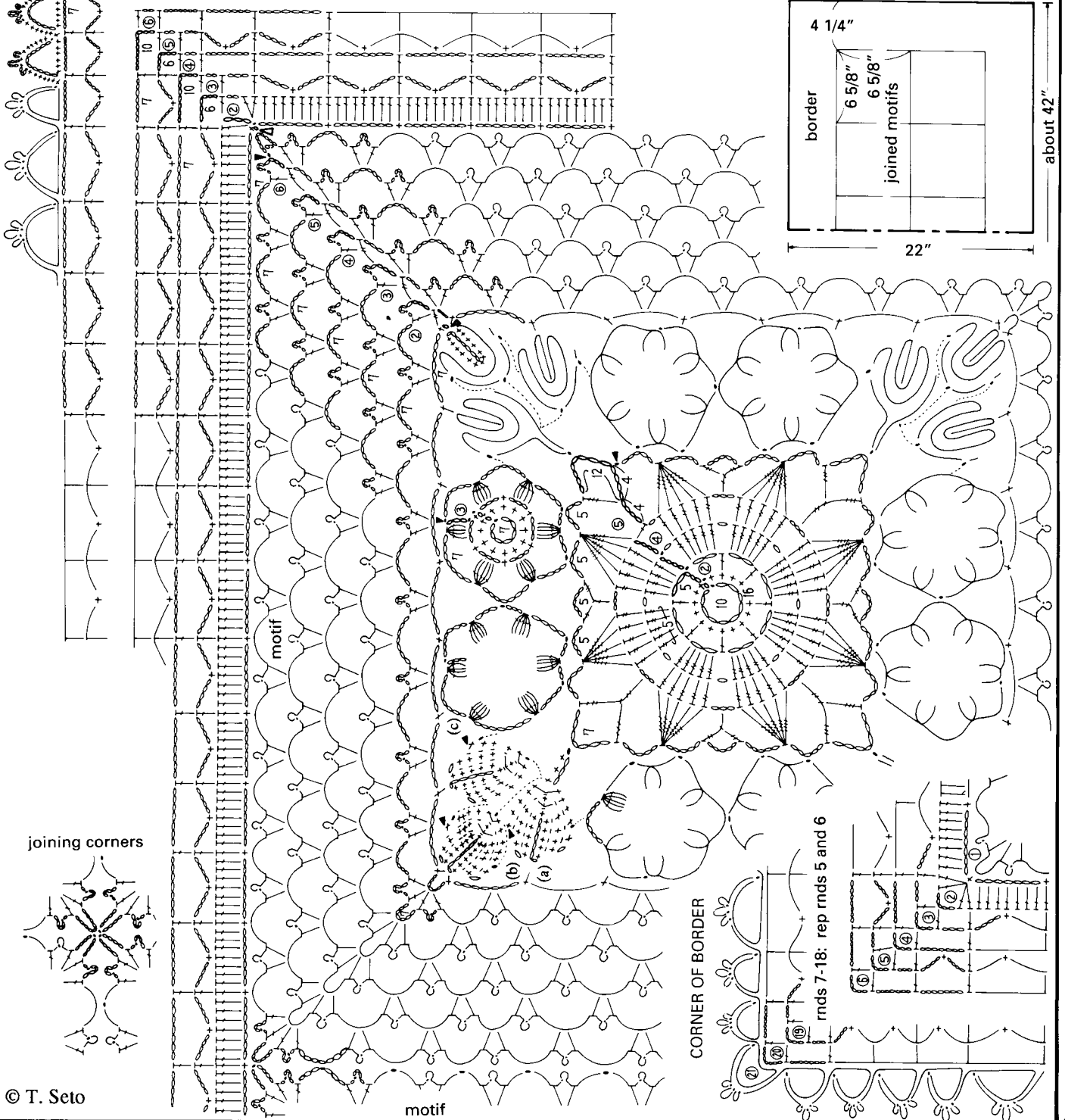
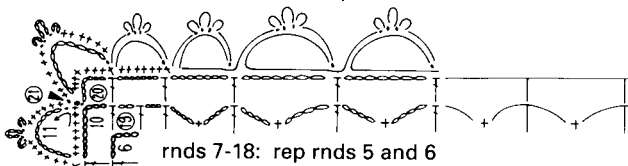

20 SUNDOWN

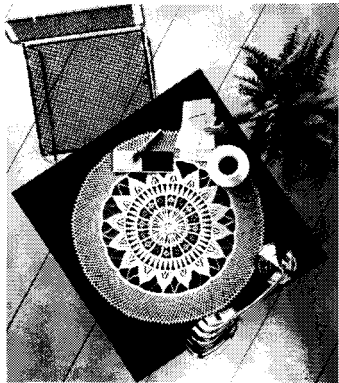

By Yoko Suzuki

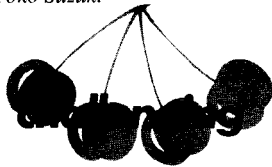

SIZE:
About 25" in diameter.

MATERIALS:
Cordonnet crochet cotton (or use fil d'Ecosse) no. 40, about 1,060 yds white, and about 40 yds each lt pink, pink, lt mauve and violet.
Steel crochet hook US size 11.

TO MAKE:
Center flower: Using white, ch 10 and join with sl st to form ring.
RNDS 1-9: Work following Diagram 1, also refer to the "Leafage" project for directions to make flower. On rnd 9, replace last 3 ch sts with dc worked in first sc. **RND 10:** * 50 ch + 1 to turn, beg in 2nd st from hook work 3 rows sc, at end of rows 1 and 3 work sl st in ch lp on rnd 9, cont with 3 ch (see tiny arrow), sl st in next ch lp, rep from * in each ch lp around; close with sl st in ch-1

 = 3-sc cluster

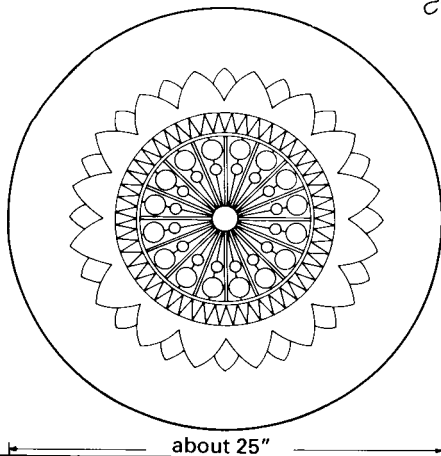

and fasten off. **RND 11:** Attach thread with sl st in top of one sunbeam (see white wedge), * 3 sc (that is, 1 sc in each sc row), 19 ch, rep from * around; up to rnd 15, close each rnd with sl st in first sc. **RNDS 12-14:** Sc all around,

as shown. **RND 15:** * 4 sc, 18 ch + 1 to turn, beg in 2nd st from hook work sc, hdc, 14 dc, hdc and sc, rep from * 95 times more. **RND 16:** Place 2 petals tog, inserting hook through both thicknesses work * 2 sc, 8 ch, rep

from * all around. **RNDS 17-18:** Sc all around as shown. At end of rnd 18, fasten off. **RND 19:** * 20 sc, 17 ch, turn, sk 5 sc, sl st in next sc, then work back and forth in rows following tiny arrows and letters (a) to (e), 1 sc in next st on

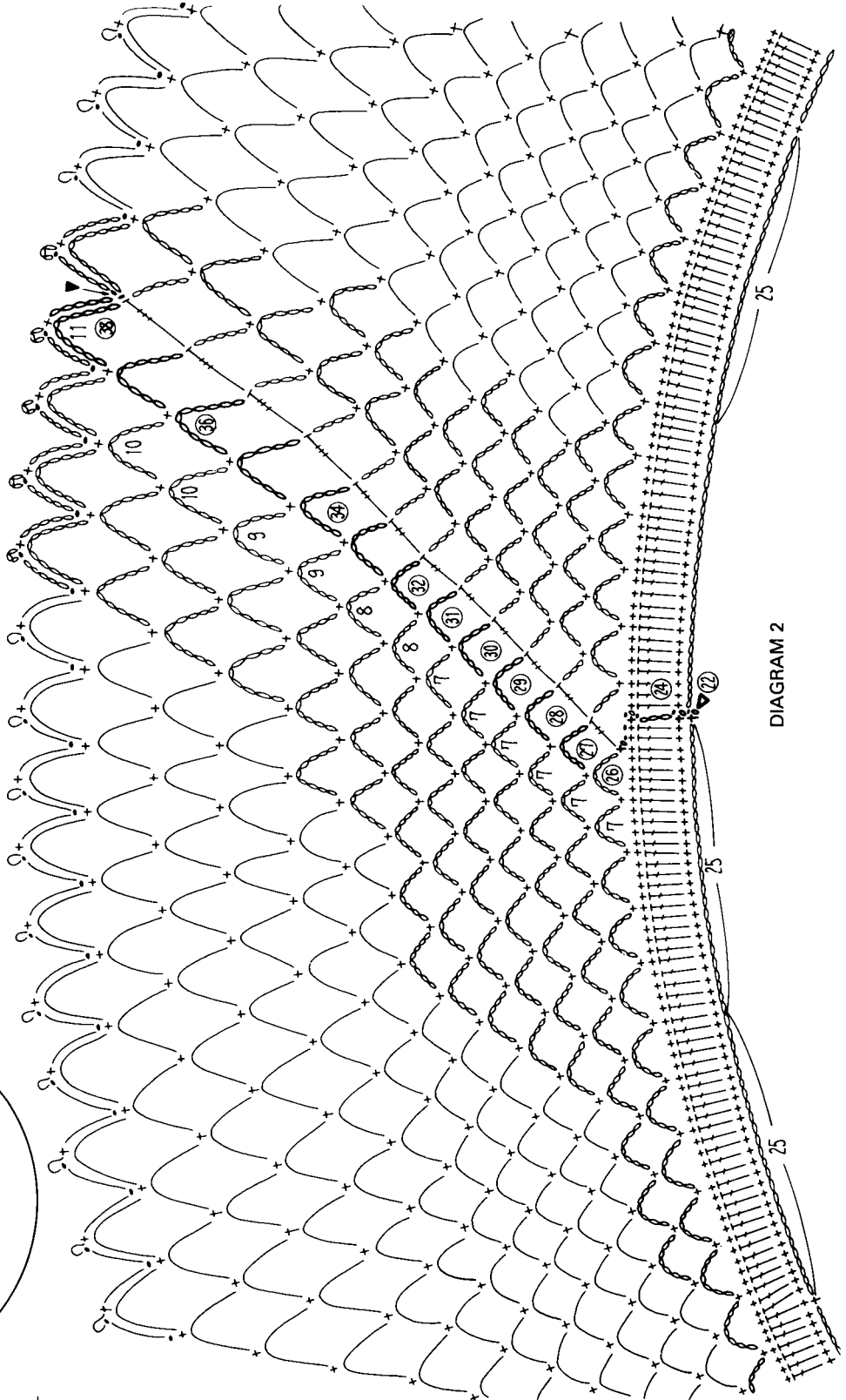

20 SUNDOWN

rnd 18, rep from * all around.
 RND 20-21: Refer to shaded area on Diagram 1 and work as shown. Bet petals work 7-dc clusters <cl> thus: leaving last lp of each st on hook and inserting hook as shown, work 7 dc, yo and draw thru all 8 lps on hook; use same cluster principle for 3-dc cls. At end of rnd 21, fasten off.

RNDS 22-39: Work following Diagram 2. On rnd 23, work 880 sc thus: 1 in each sc, 54 in each ch lp. As of rnd 26, work 176 ch lps (that is, sk 4 sts bet each sc on rnd 26). Replace last 4 ch sts of

rnds 26 to 33 with 1 tr, last 5 ch sts on rnds 34 to 37 count as double triple crochet (= yo 3 times, pull up lp in closing st below, yo and draw thru lps on hook 2 by 2). Close all other rnds with sl st.

Fill-ins: Complete picoted ch lps bet petals and flowers bet sunbeams following respective diagrams, alternate colors as shown.

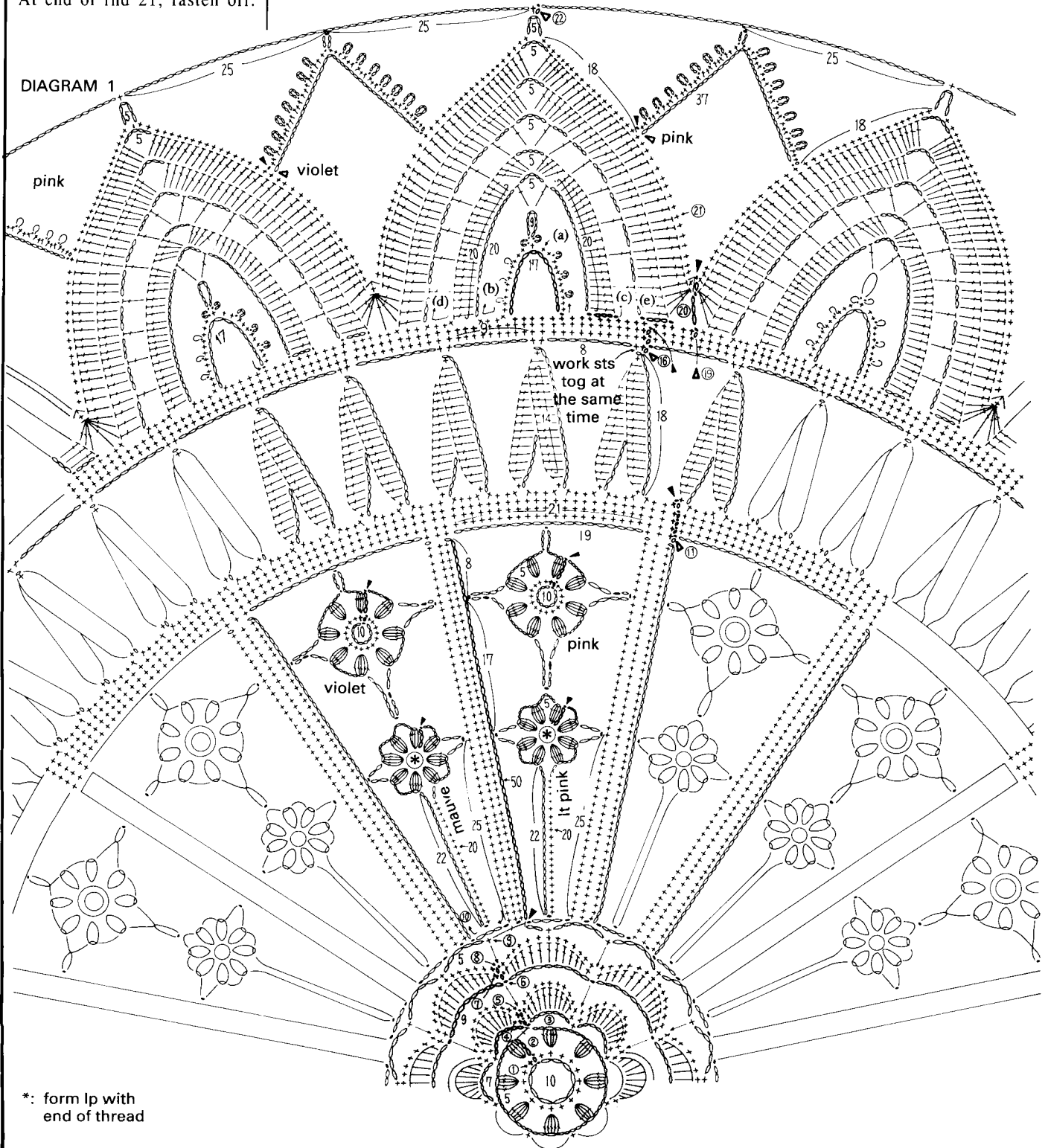

*: form lp with end of thread

21 FREE FRILL

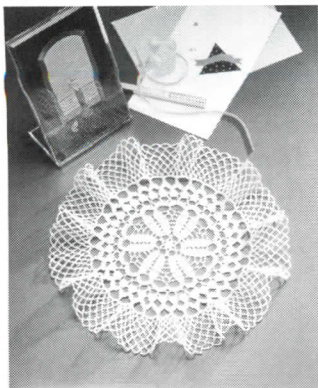

By Yoko Suzuki



SIZE:
9 3/4" in diameter.

MATERIALS:
Cordonnet crochet cotton. 40, white, about 250 yds. Steel crochet hook US size 11.

TO MAKE: Form loop with end of thread. **RND 1:** In lp work * 3-dc cl (see how-to), 5 ch, rep from * 5 times more; replace last 3 ch sts with dc worked in top of first cl. **RND 2:** In each ch lp around work dc, 1 ch, dc, 7 ch; close with sl st in top of ch-3 (= first dc throughout) and cont with sl st in each of next 3 sts to beg new rnd in first ch lp. **RNDS 3-9:** Work following diagram. For 5-dc cl on rnd 9, use same cluster principle as for 2-dc cl (see how-to). Up to rnd 8, close each rnd same as on rnd 2. On rnd 9, close with sl st in top of first cl. **RND 10:** Ch 1, beg in same st as closing sl st work sc in top of each cl, then hdc, 11 dc and hdc in each ch lp; close with sl st in first sc. **RND 11:** Sl st in each of next 4 sts, 12 ch, then work * sk 2 sts, sc in next st, 9 ch, 2 Rdc

worked from back to front (see how-to) and clustered (that is, sk 2 sts, work first Rdc around stem of next dc and work 2nd dc around stem of 3rd dc of next grp), 9 ch, rep from * around, end with sc, 9 ch, Rdc; close with sl st in 3rd st of ch-12. **RNDS 12-24:** At beg of rnd 12 work sl st in each of next 2 sts and sl st in first ch lp. Work following diagram. On rnds 17 to 20, replace last 4 ch sts with tr worked in first sc (at end of rnd 17) or in top of tr (at end of next rnds). On rnds 21 to 23, replace last 5 ch sts with double triple crochet (= yo 3 times, pull up lp in top of closing st below, yo and draw thru lps on hook 2 by 2). Close all other rnds with sl st. At end of rnd 24, fasten off (see black wedge).

 = 2-dc cluster <cl>

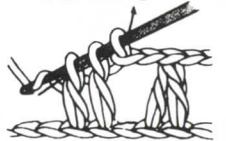

 = 3-dc cl in same st

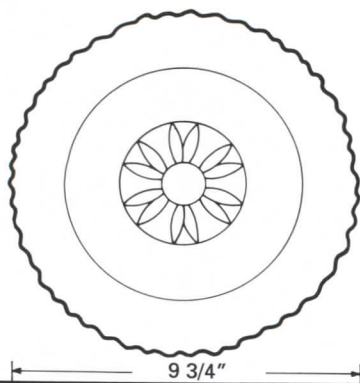
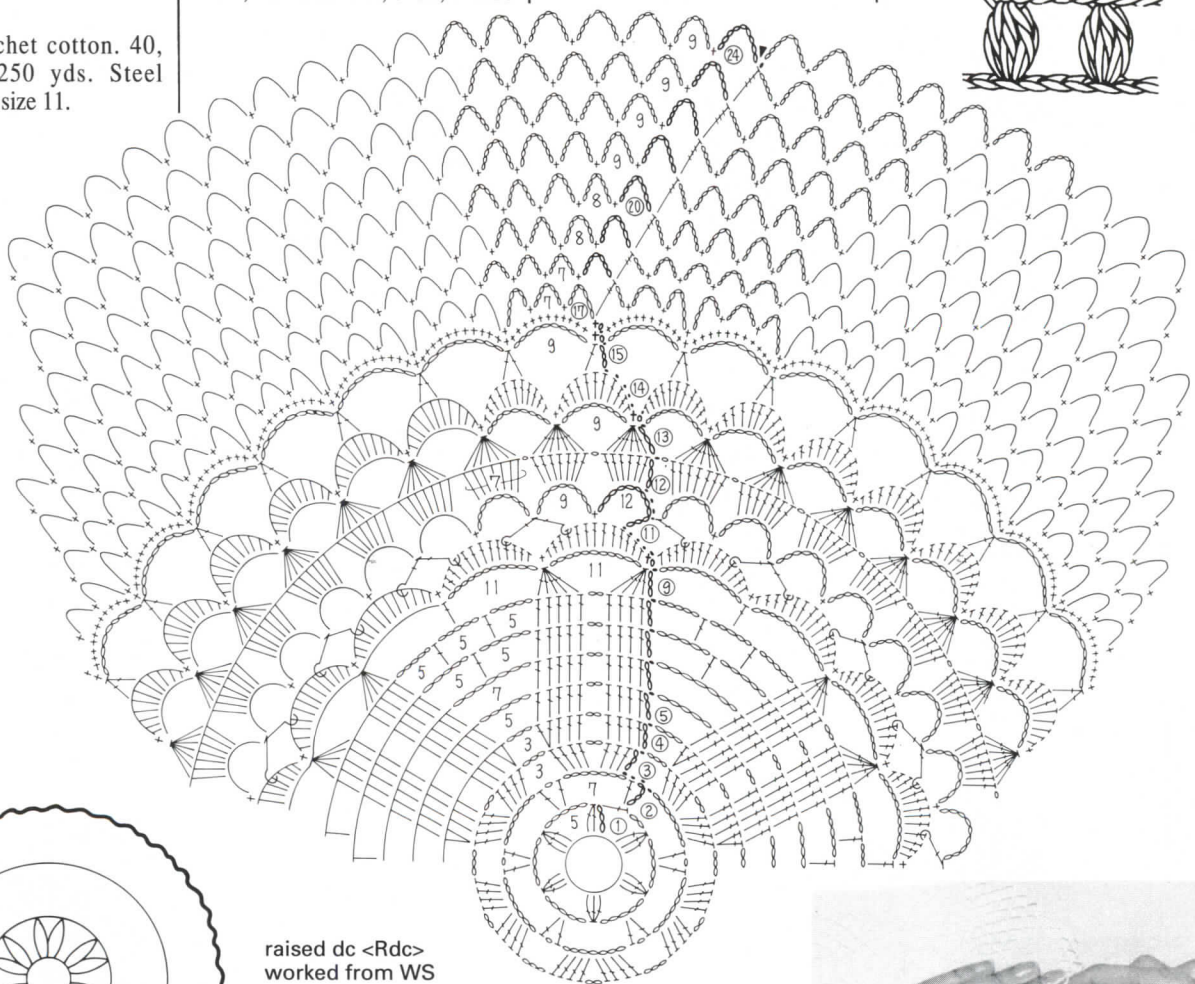

raised dc <Rdc>
worked from WS

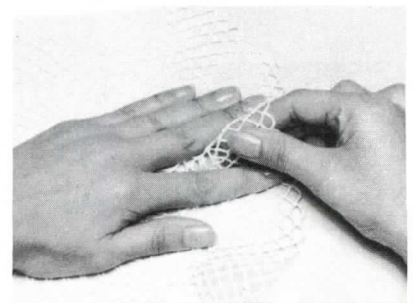
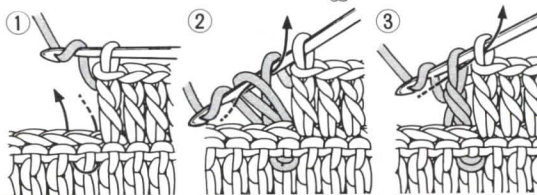

20 SUNDOWN



STONELAND HOTEL
1415 AVENUE CHURCH 1502
KING OF ISABELLA BR
BRITAIN
TEL. 25-25

HOTEL STRATFORD

21 FREE FRILL



22 EVENING BLOOM



23-24 BIRD AND BLOSSOMS-BEAUTIFUL BELL FLOWERS



22 EVENING BLOOM



By Yoko Suzuki



SIZE:
10 1/2" in diameter.

MATERIALS:
Cordonnet crochet cotton no. 40, ecru, about 250 yds. Steel crochet hook US size 11.

TO MAKE:
Form loop with end of thread. RND 1: In lp work 24 dc; close with sl st in top of ch-3 (= first dc throughout). RND 2: Work (dc, 5 ch, sk 2 sts) 8 times; replace last 3 ch sts with dc in top of ch-3. RND 3: Ch 3, work 2 dc in last ch lp, then * 2 ch, 1 shell <sh> (= 3 dc + 2 ch + 3 dc) in next ch lp, rep from * 6 times more, end with 2 ch, 3 dc in next ch lp; last ch-2 lp = 1 ch and sc in top of ch-3. RNDs 4-23:

Work following diagram. Up to rnd 21, close each rnd same as on rnd 3. On rnd 22, close same as on rnd 2. On rnd 23, close with sl st in top of ch-4 (= first tr throughout). RND 24: Ch 4, tr in 3rd st of ch-5 lp below, 1 picot (= 5 ch, sl st in top of last tr), then *** 5 ch, 3-tr cluster <cl> (= ** yo twice, pull up lp in same st as bef, * yo and draw thru 2 lps on hook, rep from * once more, rep from ** once more in top of tr, sk 2 sts and rep from ** once more in next st, yo and draw thru all 4 lps on hook), 1 picot (= 5 ch and sl st in top of last cl), rep from *** around, end with 5 ch, tr in same

st as last st; close with sl st in same st as sl st of first picot was worked. Fasten off.

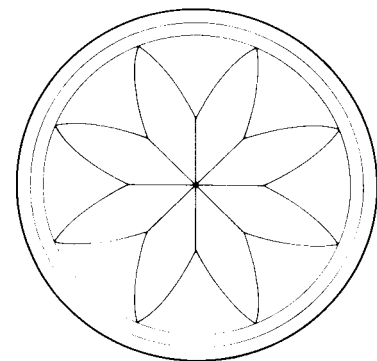
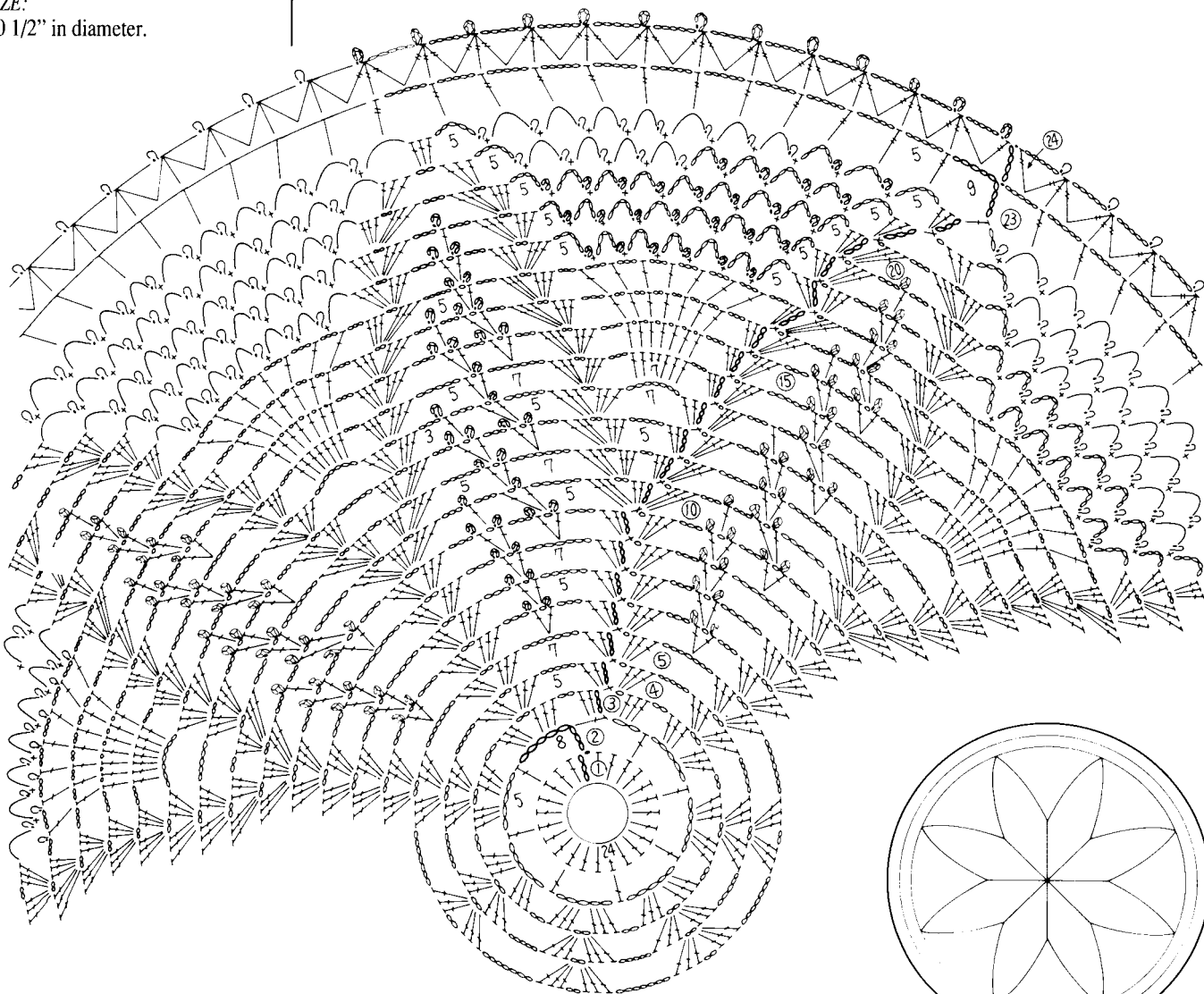

10 1/2"

23 BIRD AND BLOSSOMS



By Yoko Suzuki

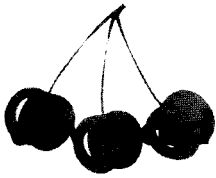

MATERIALS:

Cordonnet crochet cotton no. 40, white, about 125 yds. Steel crochet hook US size 11. Pink beads, 16. One blue bead. Fine hardanger fabric, beige, piece 6 3/4 by 8 1/4 inches. Oval picture frame, with a 5 1/2 by 4 inch opening. For tracing, dressmaker's carbon paper and hard pencil.

TO MAKE:

Flowers: Form loop with end of thread and complete 2 flowers (a) having two rows of petals and 2 flowers (b) having a single row of petals. For sc on rnd 4, fold petals toward center and insert hook under both vertical strands located on each side of sc of rnd 2.

Leaves: Complete 2 leaves A, 2 leaves E, plus one each B, C, D, F and G.

Stems: Work one chain for narrow stem and crocheted cords for the others. To create curve of main stem, work 1 row sl sts across section outlined in bold type.

Bird: Complete cord for *bird outline*, checking length against actual-size diagram. At beg and end of each *tail chain*, leave 2" thread length (for sewing to WS of fabric later).

Finishing: Trace actual-size diagram on fabric and sew each piece in place as per Assembly Diagram. After completing all appliqué work, center cardboard backing on WS of fabric and cut

fabric, adding 1 1/4" allowance from edge of cardboard all around.

Fold allowance to WS, pass gathering thread 3/8" from edge of

fabric. Pull gathering thread tight, secure. Insert picture into frame.

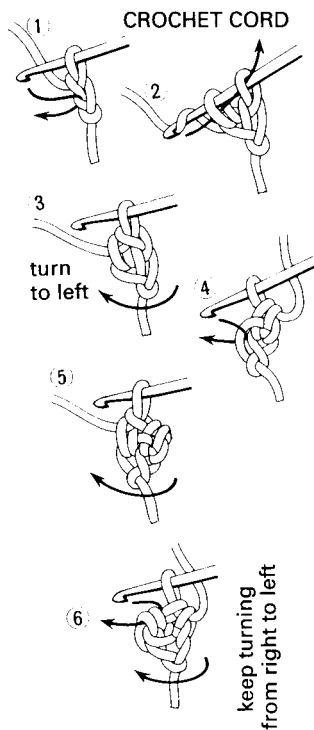

FLOWER

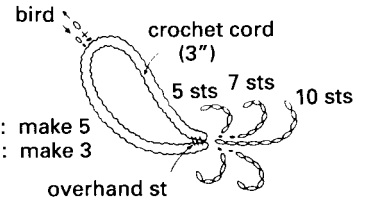
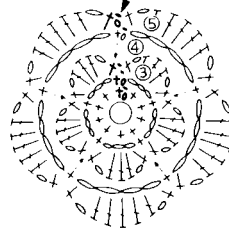

LEAVES

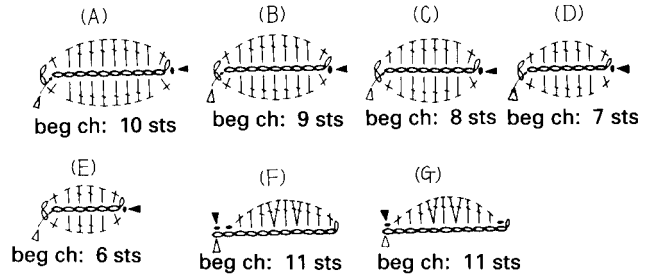

ASSEMBLY DIAGRAM (actual size)

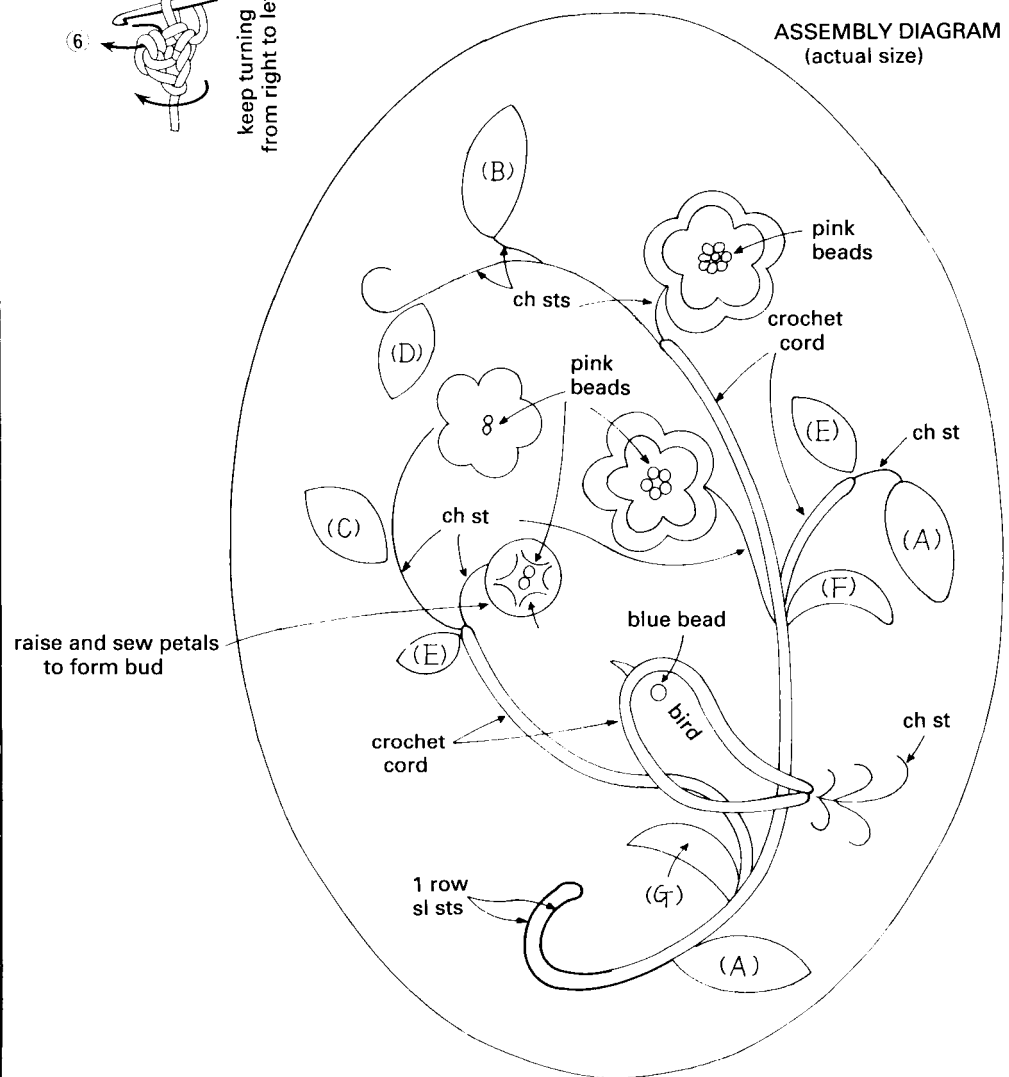

24 BEAUTIFUL BELL FLOWERS

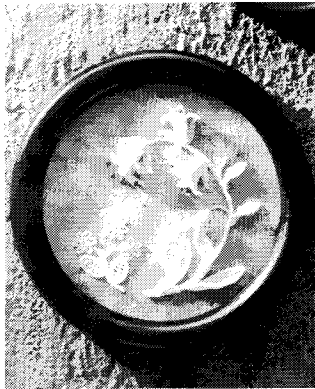

By Yoko Suzuki

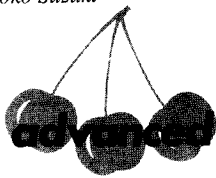

MATERIALS:

Cordonnet crochet cotton no. 40, white, about 125 yds. Steel crochet hook US size 11. Orange beads, 10. Light green cotton fabric, piece 9 3/8 inches square.

Round picture frame with opening 5 3/4" in diameter. Fine metal wire.

TO MAKE:

Petals: Complete each petal separately, as many for each flower as are required (refer to respective diagrams). Next, sew petals tog along approximately 3/8" of lower end (see "flower assembly").

Stamens: Cut six lengths of metal wire and affix one bead at each end. Prepare 2 grps of 3 stamens each, cover 3/8" of ends of each grp with sewing thread, cut wire ends even at point where thread wrapping begins. Insert one grp in Big Flower, the other grp in Medium Flower and sew in place.

Small flowers (make 2 A, 1 B): For flowers A and B and bud, form loop with end of thread, then work following respective diagram. On rnd 5 of bud, dec 1 st twice with 2-sc cluster (= pull up

lp in each of next 2 sts, yo and draw thru all 3 lps on hook).

Stems and leaves: Refer to respective diagrams.

Finishing: Trace actual-size diagram on RS of fabric using dressmaker's carbon paper and hard pencil. Hand-appliqué each piece in place with sewing thread, making small slip stitches. Sew 4 beads in place as shown. After completing all appliqué work, center cardboard on WS of fabric, adding 1 1/4" allowance from edge of cardboard all around. Fold allowance to WS, pass gathering thread 3/8" from edge of fabric. Pull gathering thread tight, secure. Insert picture into frame.

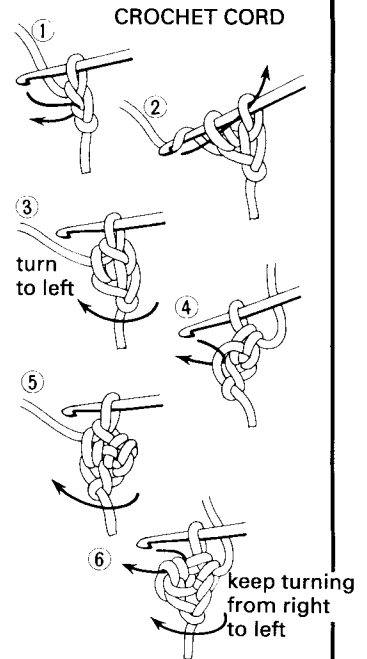

ASSEMBLY DIAGRAM (actual size)

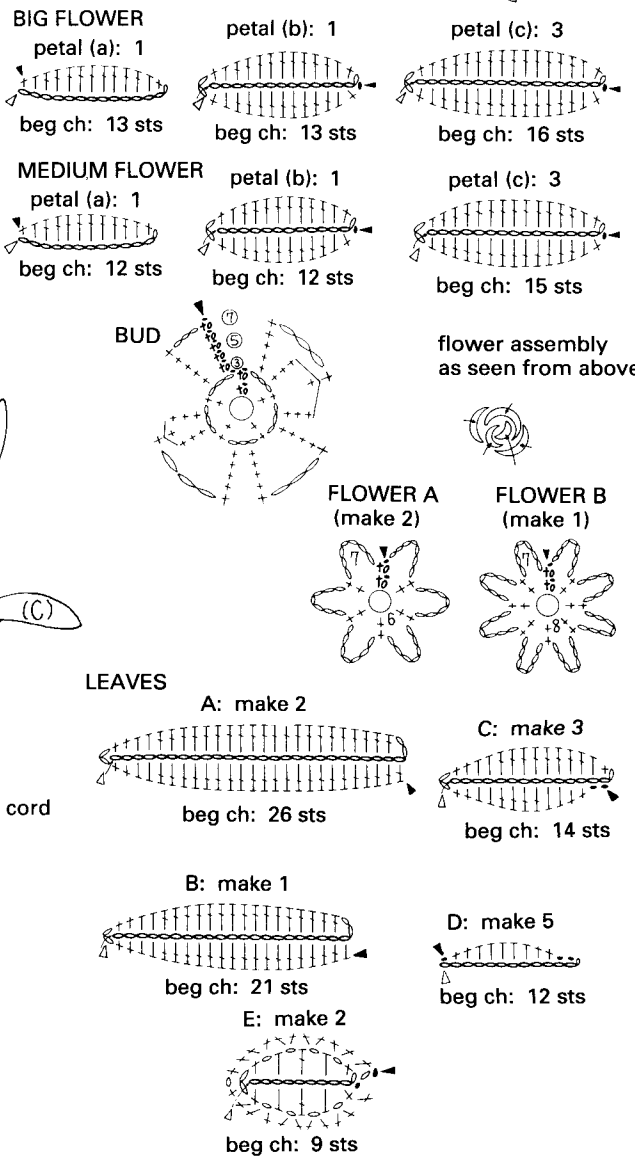
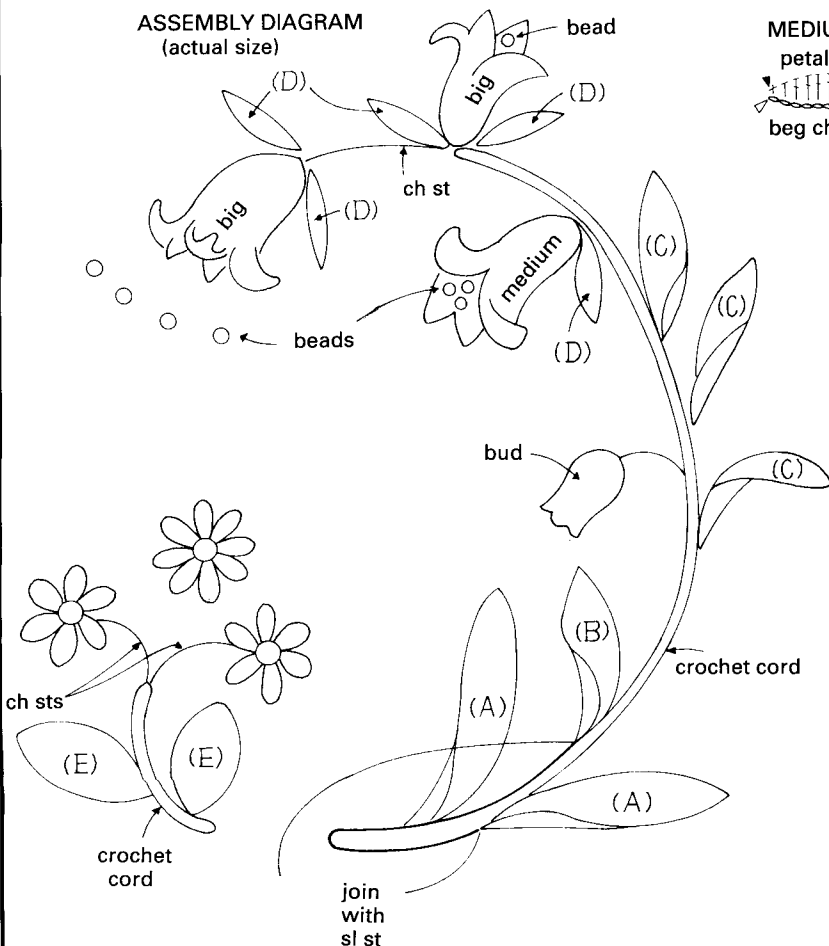

25 FULL MOON

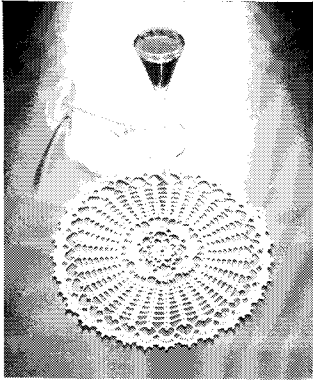

By Yoko Suzuki

SIZE:
10 1/4" in diameter.

MATERIALS:
Cordonnet crochet cotton no. 40, white, about 250 yds. Steel crochet hook US size 11.

TO MAKE:
Ch 10 and join with sl st to form ring. RND 1: Ch 1, in ring work 16 sc; close with sl st in first sc. RND 2: Work (dc in sc, 1 ch) 16 times; close with sl st in top of ch-3 (= first dc throughout). RND

3: Ch 1, beg in same st as closing sl st work * sc in dc, 2 sc in ch-1 lp, rep from * around; up to rnd 11, close each rnd with sl st (first tr = 4 ch throughout). RND 4: Ch 1, beg in same st as closing sl st work * 4 sc, 1 picot (= 5 ch, sl st

↑ = 2-sc cluster <cl> on rnd 25:
pull up lp in top of last tr of fan, rep in first tr of next fan, yo and draw thru all 3 lps on hook

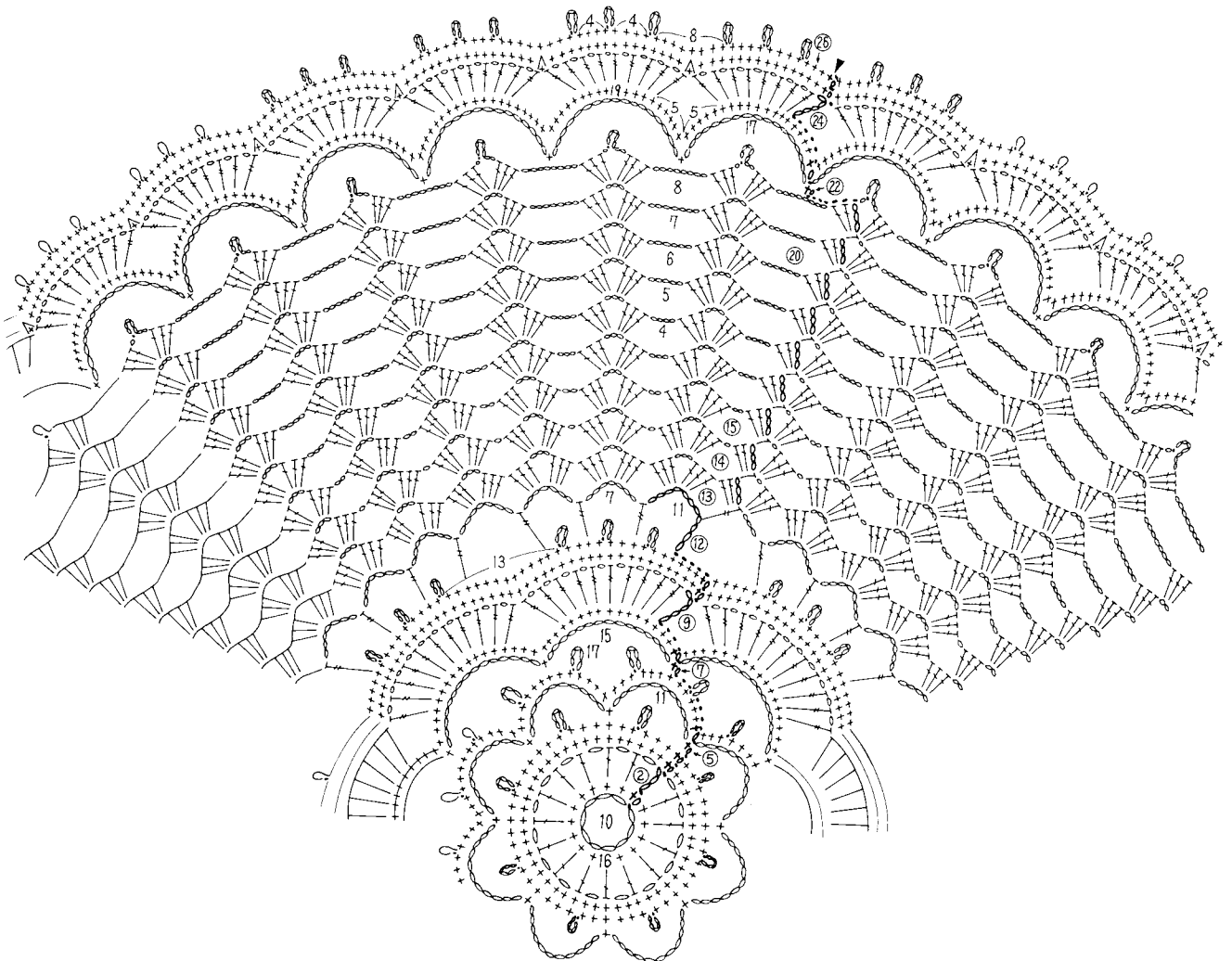
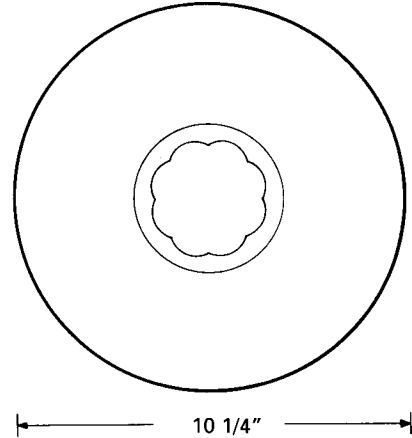

25 FULL MOON

in top of last sc), 2 sc, rep from * 7 times more. RND 5-26: Work following diagram and additional symbol. On rnds 6, 8 and 23, work sc in ch lps. Beg rnd 7 with

6 sl sts to start new rnd in center of first ch lp. On rnd 10, work sc in top of each tr and over each ch-1 lp. Beg rnd 12 with 4 sl sts to start new rnd in 5th sc. On rnd 12,

replace last 4 sts with tr worked in top of ch-4 (= first tr). On rnds 13 to 21, work dc in ch lps and, up to rnd 20, replace last 2 ch sts with hdc worked in top of ch-3 (= first

dc). On rnd 21, close with sl st, cont with sl sts to center of first ch lp, ch 1, and work each sc in center of ch lp below. At end of rnd 26, fasten off.



26 DOLCE VITA

By Yoko Suzuki

SIZE:
15 1/2" in diameter.



MATERIALS:

Cordonnet crochet cotton no. 40, white, about 500 yds. Steel crochet hook US size 11. Small leaf-shaped beads, 3 each mauve and pink.

TO MAKE:

Form loop with end of thread.
RND 1: In lp work (dc, 3 ch) 6 times; replace last 2 ch sts with hdc worked in top of ch-3 (= first and pink.



26 DOLCE VITA

dc throughout). RND 2: Beg with 3 ch and dc in last ch lp, then work * 1 ch, 1 shell <sh> (= 2 dc + 2 ch + 2 dc) in next ch lp, rep from * 4 times more, end with 1 ch, 2 dc in next ch lp; close with 1 ch and sc in top of ch-3. RNDs 3-30: Insert hook over ch sts and work following diagram; close each rnd same as on rnd 2. On rnd 16, bet

sh surrounding petals, work thus: 5 ch, sc in first ch-2 lp, * 5 ch, sc in next ch lp, rep from * 3 times more, sc in dc, sc in ch-7 lp, ** sc + 1 picot (= 3 ch, sl st in top of last sc) + sc in same ch lp, rep from ** twice more, sc in next dc, sc in next ch lp, 4 ch lps same as bef and 5 ch. RND 31: ** 5-tr cluster <cl> (= leaving last lp of

each st on hook, work 2 tr in ch lp of sh, 1 tr in ch lp bet 2 sh and 2 tr in ch lp of 2nd sh, yo and draw thru all 6 lps on hook), 1 picot (= 5 ch, sl st in top of last cl, inserting hook bet 2 horizontal and under 5 vertical strands located below the horizontals), 5 ch, sc in next ch lp, 5 ch, * 5-dc cl, 1 picot same as bef, 5 ch, sc in next ch lp, 5 ch, rep

from * 8 times more, rep from ** all around; last 3 ch sts = dc worked in top of first 5-tr cl. RNDs 32-39: On rnd 32, insert hook for popcorns in sc, on next 2 rnds in ch lps and work following diagram. At end of rnd 39, fasten off (see black wedge).

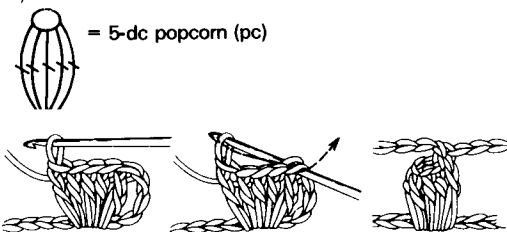
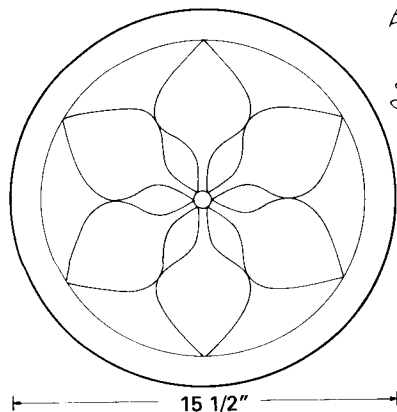
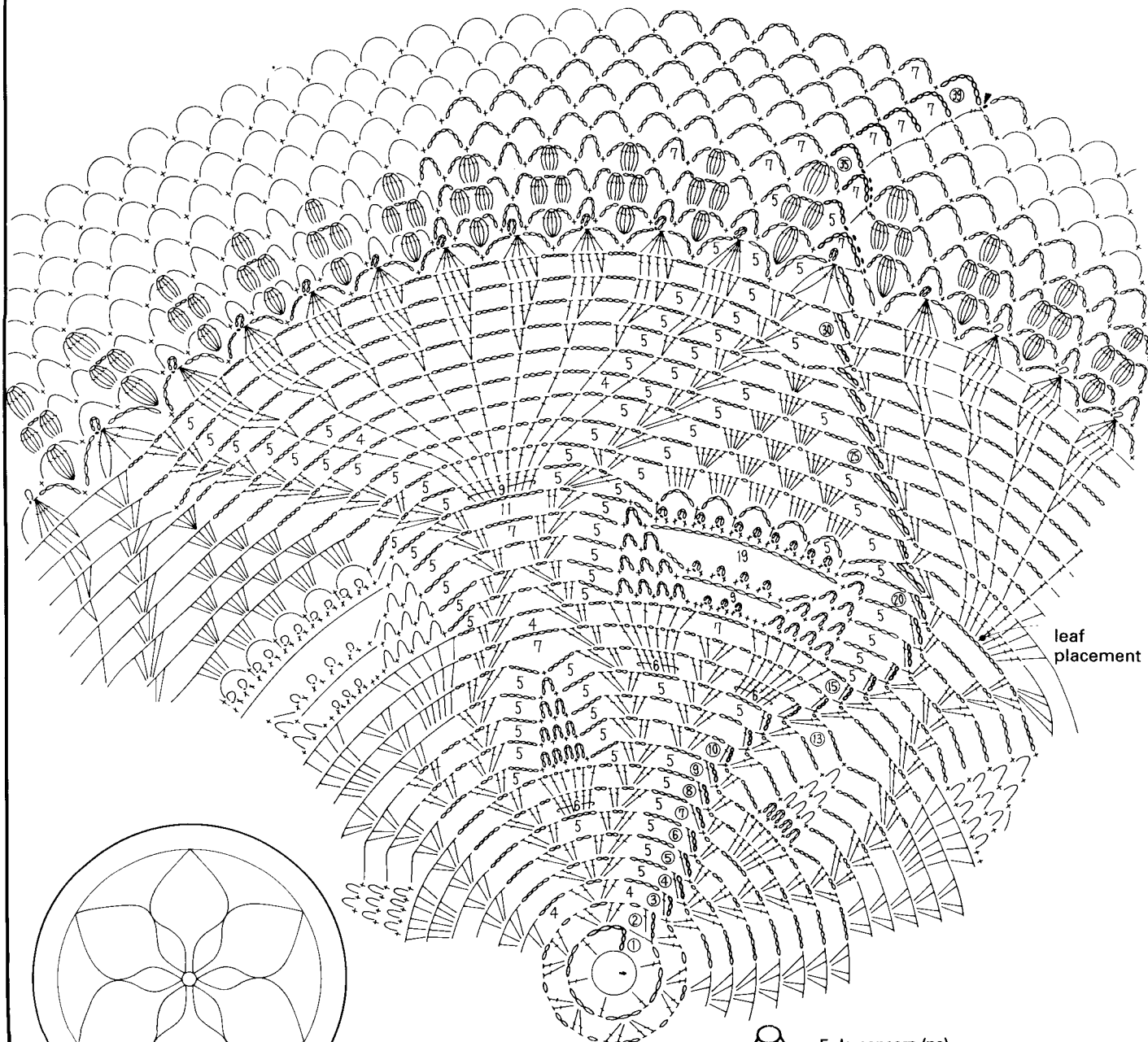

HOW TO WORK PATTERNS FROM OUR DIAGRAMS

On this page and the next, you will find the key abbreviations and symbols used in our diagrams and instructions. Step-by-step illustrations show newcomers how to work the basic stitches and techniques. Additional abbreviations or symbols needed for a specific project will be included and explained with that pattern.

Note that, in each diagram, rounds or rows are numbered in lightface, while a boldface number inside a loop indicates how many chain stitches to work in that loop.

Abbreviations

beg	begin(ning)
bet	between
ch	chain (stitch)
ch-	chain(s) previously made
cont	continue
dc	double crochet
dec	decrease
grp(s)	group(s)
hdc	half double crochet
inc	increase
lp(s)	loop(s)
m	mesh(es)
p	picot
pat(s)	pattern(s)
prev	previous
rep	repeat(ing)
rnd(s)	round(s)
RS	right side
sc	single crochet
sk	skip
sl st	slip stitch
sp(s)	space(s)
st(s)	stitch(es)
Tch	turning chain
tog	together
tr	triple crochet
WS	wrong side
yo	yarn over hook

CHAIN (also beginning chain)

(ch) 
or chain stitch
(ch st)

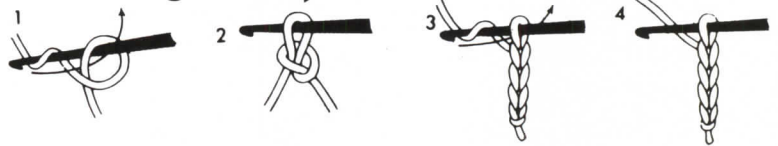

SINGLE CROCHET

(sc) 



Insert hook from front to back in next stitch under both upper strands, yarn over hook pull up loop (2 loops on hook), yarn over hook and draw thru 2 loops on hook.



SLIP STITCH

(sl st) 



Used to form ch sts into ring, to join motifs and edges, to start loops in center of previous loops, and so on.

HALF DOUBLE CROCHET

(hdc) 



Ch 2 to turn.



DOUBLE CROCHET

(dc) 



Ch 3 to turn



TRIPLE CROCHET

(tr) 



Ch 4 to turn.

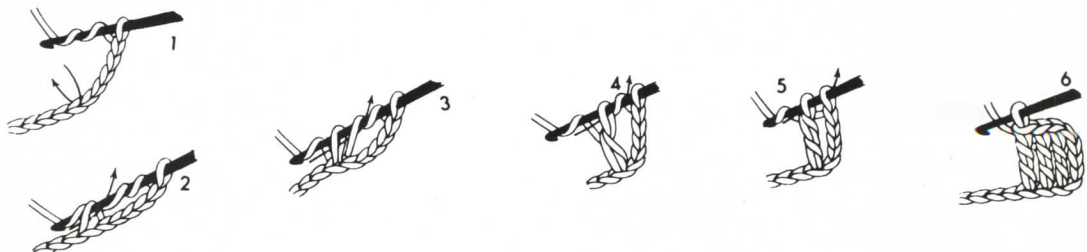

THREE WAYS TO MAKE A PICOT (p)

Work desired number of extra ch sts, then continue in original st (1). Work extra ch sts, then join with sl st (2) or sc (3) in first stitch of picot chain.

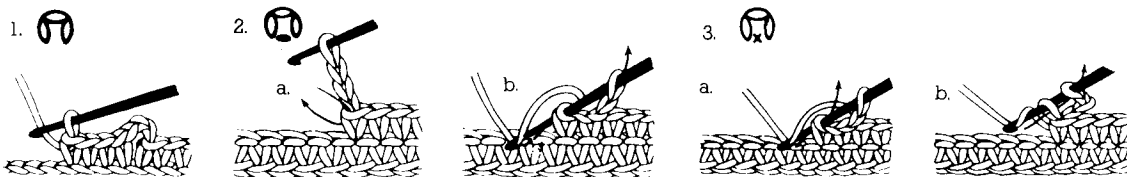

THREE WAYS TO BEGIN

1. Work ch, join with sl st to form ring.

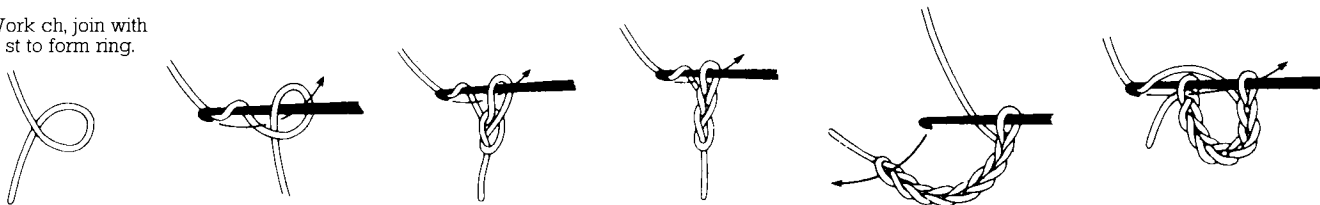

2. Form loop with end of yarn.

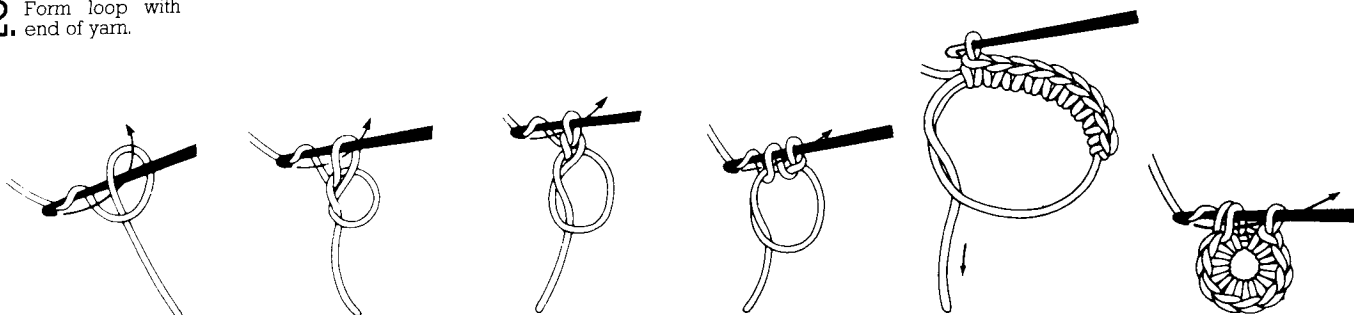

3. Form double loop with end of yarn.

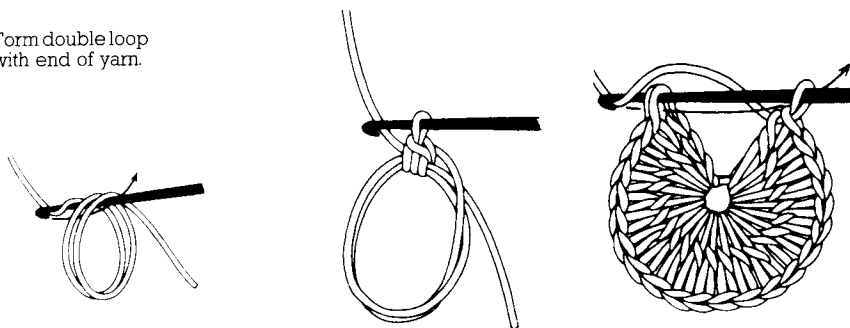

RAISED HALF DOUBLE CROCHET (R hdc)

Yarn over hook, insert hook from front to back to front around stem of st below, yarn over hook, pull up loop, complete as hdc. Work R dc or R sc in same manner.



FASTEN OFF

with hook

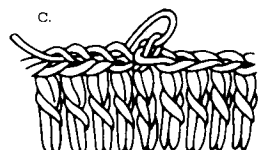
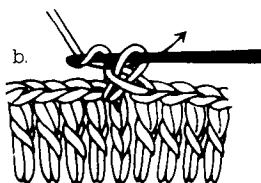
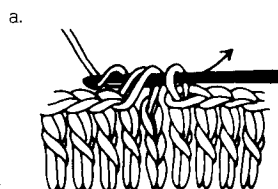

FASTEN OFF

with needle

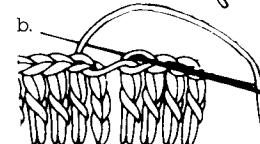
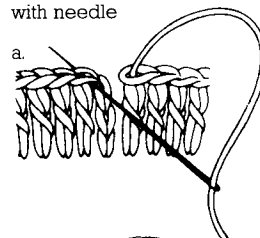

ATTACH YARN

CUT YARN

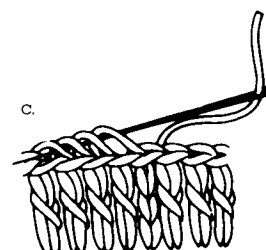

CROCHET BASICS

OPEN AND SOLID MESHES

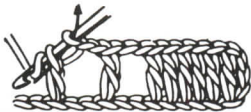

FILET STITCH

INCREASES

AT END OF ROW

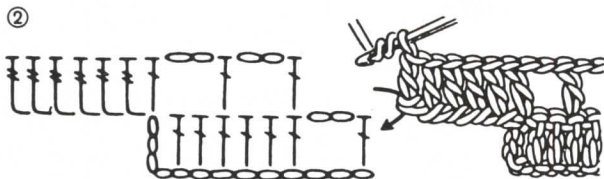
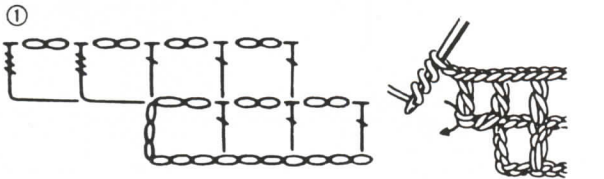

AT BEG OF ROW

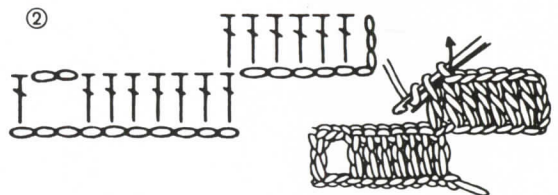
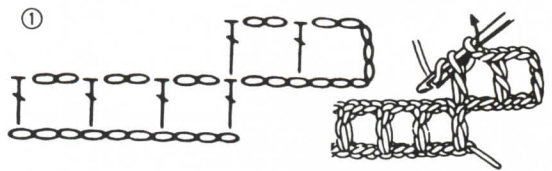

DECREASES

AT END OF ROW

① cluster 1 trtr with 1 dc

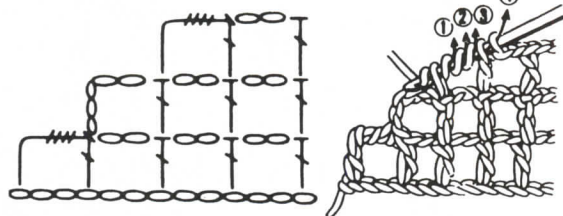

② work 4 partial dc, dec with 4-dc cluster

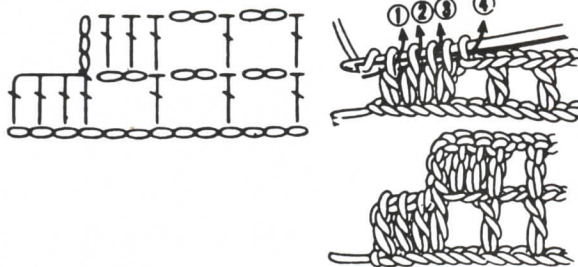

AT BEG OF ROW

① work sl sts to dec

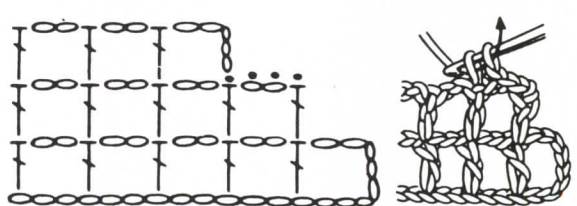

② dec with trtr

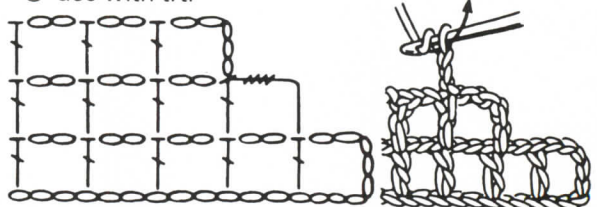

BIASING

Increase



Decrease

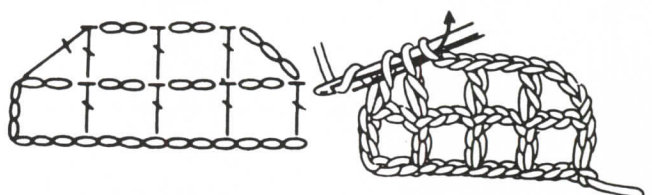

JOINING TWO MOTIFS

① with a double crochet

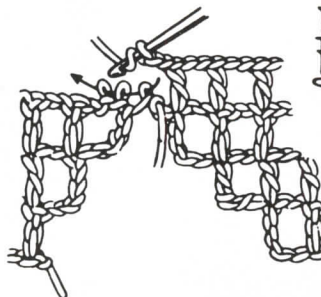
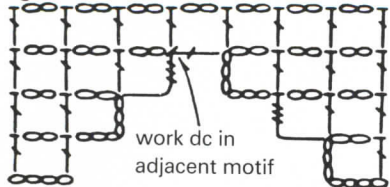

② with a chain stitch

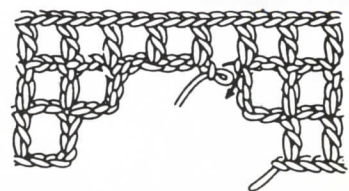
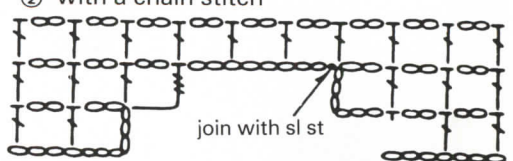

How to follow the diagrams

There are very few stitches you need to know for the craft of crochet. Artistic effect in designs and patterns depends on how skillfully you vary and alternate these basic stitches.

Our diagrams are especially created to give you graphic assistance every step of the way by using a symbol system linked up to the written instructions. Every stitch has its own clear symbol. At any point you can compare your own progress with the diagram and see exactly where you are in your pattern. The symbol diagram system is a modern and up-to-date approach. You'll certainly find it a big improvement over the old method of descriptive instructions only.

For quick and easy crocheting, follow the written instructions, making sure to check the abbreviations, and use the diagram as your mainstay. While you are getting used to this system, it's a good idea to refer to the explanations of the symbols in the back of the magazine.

Together, let us look at a sample diagram to show you just how the system works. Rounds (or rows) are numbered in lightface. A boldface number inside a chain loop tells you how many chain stitches you need for that loop. The chain stitch is abbreviated as ch or ch st and its symbol is a hollow oval. In our sample diagram, a loop on round 6 has 4 stitches, while on round 8 it has 9 stitches. On round 6, you are working in groups of 5 triple crochets, for which the abbreviation is tr and the symbol is $\frac{1}{3}$. As of round 5, only part of each round is shown because the same sequence of stitches is repeated all around. However, you can see the beginning and end of each round throughout the pattern.

Some of our patterns require variations of stitches, and these will appear as special clearly-explained symbols alongside the diagram. For more advanced crochetwork, we will also include diagrams of details (edgings, joinings, assembly) or of the completed work. Cherry symbols will show you at a glance the skill level needed for each pattern.

Now, you can go ahead and start work on the project of your choice. Remember, the art of crochet is truly simple: all you need is a hook, a ball of thread and one of our lovely patterns to guide you. But please be sure to pay close attention to the written instructions as you proceed, since they may contain some essential data that could not be included in the diagram.

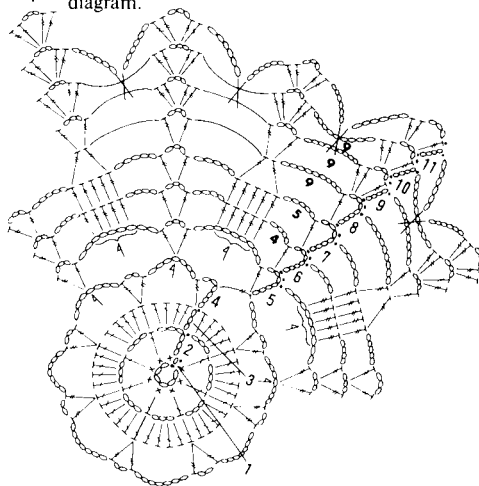

Sample gauges for classical threads

Six-cord crochet cotton number	American hook size	Size of swatch
5	7	3" x 3" = 33 dc x 15 rows
10	8	3" x 3" = 36 dc x 16 rows
20	9	3" x 3" = 40 dc x 16 rows
30	10	3" x 3" = 45 dc x 18 rows
40	11	3" x 3" = 47 dc x 19 rows

For information on buying threads write to (enclose SASE):

In the USA

BUCILLA, Attn: Yarn Design, 150 Meadowlands Pkwy, Secaucus NJ 07094.

COATS & CLARK, Consumer Service Dept, 6900 Southpoint Dr. N., Suite 200, Jacksonville FL 32216.

COTTON CLOUDS, Route 2, Desert Hills Nr 16, Safford AZ 85546.

DMC CORPORATION, Port Kearny Bldg Nr 10, South Kearny NJ 07032-0650.

In Canada

COATS, 337 Evans Avenue East, Etobicoke ON M8Z 1K2.

All about cottons and hooks

There are many types of crochet thread on the market, and several types of hooks. To help you choose the right yarn and the right hook, here is a description of the more common crochet cottons, with their yardage, and a chart of hook size equivalents. Keep in mind that your individual crocheting style may call for a slightly thicker or thinner hook than the one recommended for a specific project.

CLASSICAL THREAD: Six-cord crochet cotton is available in several colors and thicknesses (the higher the number, the finer the thread), and it is tightly twisted.

Four-cord, three-cord or unrecorded thread is less expensive and easy to obtain.

Each ball weighs 20 grams, or approx. 3/4 of an ounce.

No. of cotton thread	Inter- national hook size	Ameri- can hook size
3 (83 yds)	1.75	4
5 (111 yds), 10 (124 yds)	1.50	8
15 (136 yds), 20 (174 yds), 30 (216 yds)	1.25	10
40 (249 yds), 50 (286 yds)	1.00	12
60 (324 yds)	1.00 or 0.75	12 or 14
70 (361 yds), 80 (398 yds)	0.75	14
100 (472 yds), 120 (508 yds), 150 (584 yds)	0.60	16

FANCY YARNS: Each ball weighs 50 grams, or approx. 1 3/4 oz.

Cebelia: California cotton, 3-ply, with a sheen.

No. 5 (141 yds)	2.00	0
No. 10 (282 yds)	1.50	8
No. 20 (405 yds)	1.25	10
No. 30 (563 yds)	1.00	12

Fil d'Ecosse No. 5, 8-ply, special twist, with a sheen (184 yds) 2.00 0

Pearl cotton: Egyptian cotton, 2-ply, loosely twisted

No. 5 (266 yds)	2.00	0
No. 8 (482 yds)	1.50	8

Ordinary crochet cotton, 2-ply (230 yds)

1.75	4
------	---

Knitting cotton

No. 4: Egyptian cotton, 6-ply, with a high sheen (224 yds) 2.00 0

Soft knitting twist: California cotton, 5-ply, mat, loosely twisted.

Gives a rustic look to your project. Various shades and thicknesses.

No. 4 (175 yds)	2.50	1
No. 6 (262 yds)	2.00	0

27 DELUXE LIFESTYLE

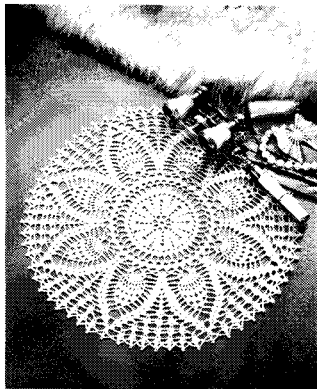

By Yoko Suzuki

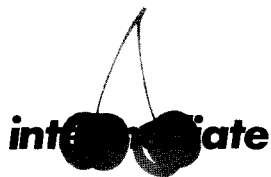

SIZE:
12 1/4" in diameter.

MATERIALS:
Cordonnet crochet cotton no. 40, ecru, about 375 yds. Steel crochet hook US size 11.

TO MAKE:
Ch 10 and join with sl st to form ring. RND 1: Ch 1, in ring work 16 sc; close with sl st in first sc.

RND 2: Work (dc in sc, 5 ch, sk 1 st) 8 times; up to rnd 7, close each rnd with sl st in top of ch-3 (= first dc throughout). RND 3-8: At beg of rnd 3, work sl st to start rnd in first ch lp and cont as per diagram. On rnd 8, close same as on rnd 1, then cont with 2 sl sts to beg rnd 9 in center of first ch lp.

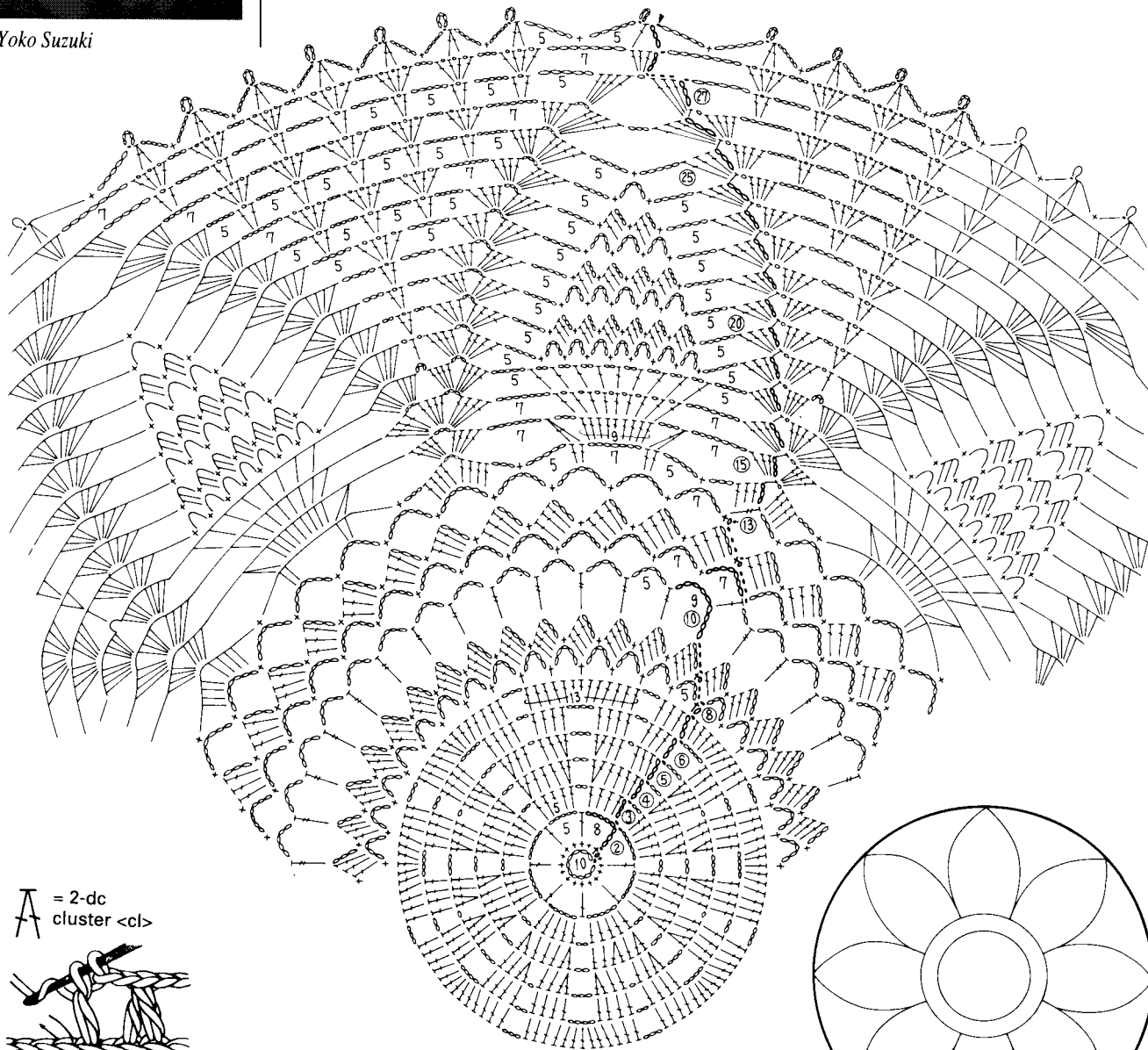

A = 2-dc cluster <cl>

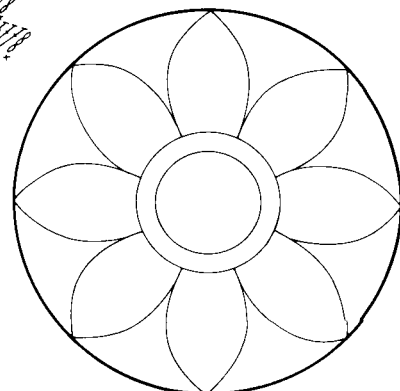
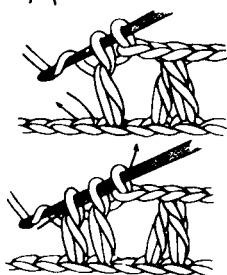

12 1/4"

27 DELUXE LIFESTYLE

RND 9: Ch 1, in each ch lp around work sc, 3 ch and 3 dc; close same as on rnd 8 and cont with 3 sl sts: 1 in each of next 2 sts and 1 over next ch st. RND 10-28: On rnd 10, work tr bet ch-

3 lp and first dc of 3-dc grp and cont as per diagram. On rnd 10, replace last 3 ch sts with dc in top of ch-4 (= first tr). On rnd 13, replace last 4 ch sts with tr in first sc. On rnds 14 to 26, last 2 ch sts

= hdc in top of ch-3. Close all other rnds with sl st and cont with sl sts to st where next rnd begins. RND 29: Inserting hook in corresp dc work * 2-dc cl (see how-to), 1 picot (= 5 ch, sl st in

top of last cl: insert hook bet 2 horizontal strands and under the 2 vertical strands located below), 5 ch, sc in next ch lp, 5 ch, rep from * around; close with sl st in same st as st of first picot. Fasten off (see black wedge).



