

The UK's No.1 sewing mag



Sizes
8-20

love Sewing

All is
BRIGHT

Make me
TONIGHT

Simple Sew
cosy raglan
sweatshirt

- ♥ **Gifts for all the family**
- ♥ Plan a seasonal wardrobe
- ♥ **Festive fabric inspiration**

MASTERCLASS

Better bound
buttonholes



*Delicate
embroidered*
HEART



Hot water
BOTTLE CASE

The secrets of sewing
**LUXE
LACE**

ISSUE 45 UK £6.99

Inspire
Imagine 9
Create

www.love sewingmag.co.uk



threaders™

BY CRAFTER'S COMPANION



MERRY & BRIGHT FABRIC RANGE

BOLT FABRIC AND
FAT QUARTER BUNDLES
AVAILABLE



See the complete fabric range online at:
www.crafterscompanion.co.uk

Welcome

... to issue 45
of Love Sewing

When you get a specific project idea in your head it's hard to shake isn't it? Everything else from your sewing queue flies out the window and the fabric you had freshly washed and pressed doesn't hold the same appeal. This thrill to get started on something new has currently taken hold of me when I know I should be starting some festive makes.



Stitching pretty

After a spell of rainy weekends watching old black and white movies while sewing, I can't stop thinking about 1940s silhouettes. I've cut out another version of McCall's 7381 (our issue 37 free gift) in pink rayon to get myself started and I'm itching to make another 40s-style tea dress. I'm currently bouncing between the Maven Patterns Rochester dress, which has a chic gathered neckline and waist ties

(www.mavenpatterns.co.uk), and the new Liria button-down dress from Pauline Alice patterns (www.backstitch.co.uk). I'm imagining a luscious floral version using a rose-print crepe de chine from www.tilthesungoesdown.com and I have some pretty silk in my stash that would make a dressier version. Now I just need the time to make them up! A familiar story to you all I'm sure.

Also on the agenda is finding cute patterns for a cheeky one-year-old girl. My niece has her birthday in November and then there's Christmas hot on its heels so I figured a little wardrobe boost would be a fun way to spoil her. I've



See Cheryl's dress
on page 23

Meet the TEAM



Denise

ART EDITOR

Denise is passionate about design, sewing, good food and fluffy cats. She has a keen eye for detail and knows how to work the latest trends into your craft room. See more at www.instagram.com/by_denisej



Bethany

DEPUTY EDITOR

Bethany loves nothing more than indulging in a quiet spot of cross stitch in her free time. She's also the creator of the Make It Betty 'Sketch it Stitch it' notebooks available at www.makeitbetty.etsy.com



Leanne

EDITORIAL ASSISTANT

Multi crafter Leanne is a keen artist and a dab hand at creating decorations with sequin pins. When she's not working she's at home with the love of her life, her border collie Daisy. See more at www.instagram.com/leanne1991

got a range of fabric from Cloud9 in sweet pastel printed cotton, flannel and jersey so please send me recommendations to letters@lovesewingmag.co.uk and I'll share my makes next time.



Button-down beauty

Happy sewing!
Amy

Inside this ISSUE

REGULARS AND FEATURES

- 3 Welcome
- 6 Love Sewing Loves
- 9 20% off patterns at Fabric HQ
- 10 15 mins with Christina from Wardrobe By Me
- 12 Machine reviews
- 14 A brief history of pyjamas
- 23 Reader Review – McCall's 6884
- 24 Fabric Focus – Deck the halls!
- 26 **SUBSCRIBE TODAY**
- 28 *The Dressmaker's Diary* with **Elisalex de Castro Peake**
- 32 Win 90 patterns from Simplicity!
- 35 The Cocktail Hour News
- 36 *Thrifty Stitcher* with **Claire-Louise Hardie**
- 38 Shop of the month
- 40 Handmade gift inspiration
- 44 Sewing workshops
- 55 In the good books
- 56 Save 20% on jersey fabric at Higgs & Higgs
- 58 *Behind the seams* with **Wendy Ward**
- 60 Pattern Picks – Save 50% on these McCall Pattern Co. designs
- 67 This month I'm making
- 68 *Swatch Selector* with **Kerry Green**
- 73 **DISCOUNTS & GIVEAWAYS**
- 80 Shop local to receive your free gift from Gütermann
- 83 Readers' makes

Your new favourite
T-shirt dress!



Receive a **free** copy of *Sewing Your Perfect Capsule Wardrobe* when you subscribe to *Love Sewing* – see page 26 for info

- 84 *Skill building* with **Wendy Gardiner**
- 86 **Jade Earley** the girl with the red hair
- 88 Couture sew-along with **Alison Smith MBE**
- 90 **PATTERN READING BASICS & FITTING ESSENTIALS**
- 96 **COMING NEXT ISSUE**



18

PROJECTS

- 18 Your free McCall's pattern gift – It's a wrap!
- 30 Some like it hot water bottle cover
- 47 The full ponte trousers
- 50 Show some love heart embroidered cushion
- 53 Your second free gift – Dapper dog coat
- 69 Scarlet fever button-down skirt
- 78 Connect the dots 50s purse
- 93 Star make sweatshirt
- 98 Puppy patrol brooches

Find us online

www.love sewingmag.co.uk



/love sewingmag

Dapper dog coat



53



69



30



73

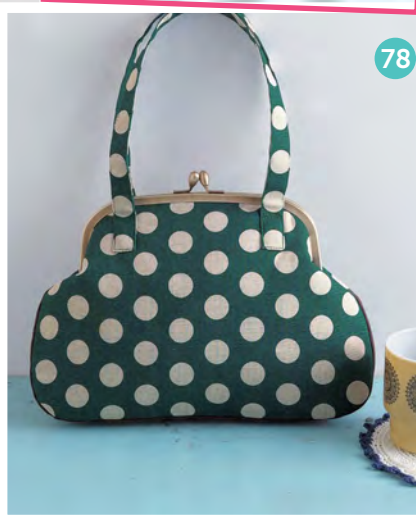

78



40

Editorial

Editor Amy Thomas
Deputy Editor Bethany Armitage
Editorial Assistant Leanne Brocklehurst
Senior Sub-Editor Justine Moran
Sub-Editor Kayleigh Hooton
Senior Art Editor Denise Johnson
Art Editor Simon Kay
Senior Product Photographer Tym Lecky
Photographers Renata Stonyte, Amy Worrall
Hair & make-up Nina Rochford
Contributors Claire-Louise Hardie,
Alison Smith MBE, Elisalex de Castro Peake,
Wendy Ward, Jade Earley, Wendy Gardiner, Kerry Green

Publishing & Advertising

Head of Softcrafts
Ruth Walker
Advertising Sales Executive
Noune Sarkissian
noune.sarkissian@practical
publishing.co.uk
Advertising Consultant
Amanda Paul
Subscriptions Manager
Daniel Tutton
Managing Editor Kate Heppell
Managing Art Editor Jennifer Lamb
Head of Content & Positioning Gavin Burrell
Group Buying Manager Olivia Foster
Buying Assistant Rachael Edmunds
Production Assistant Anna Olejarz
Distribution Manager Lauren Murray
Financial Director Chris Dunbar
Strategy & Insights Director Dave Cusick
Managing Director Danny Bowler
Group Managing Director
Robin Wilkinson

Distribution

Newtrade COMAG Magazine Distribution
cathy.phillips@practicalpublishing.co.uk
Tel 0844 826 0613

Contact

Practical Publishing International Ltd,
Suite G2 St Christopher House,
217 Wellington Road South,
Stockport SK2 6NG
customerservice@practicalpublishing.co.uk
www.practicalpublishing.co.uk
Tel: 0844 561 1202
Fax: 0161 474 6961

Subscription Enquiries

Tel: 01858 438899
practicalpublishing@subscription.co.uk

Love Sewing is published by Practical Publishing
International Ltd ISSN 2054-832X

All material © Practical Publishing International Ltd. The style and mark of Love Sewing is used under licence from Craft Media Ltd. No material in whole or in part may be reproduced, stored or transmitted in any form whatsoever without the prior written consent of Practical Publishing International Ltd. The publisher welcomes contributions from readers.

All such contributions and submissions to the magazine are sent to and accepted by the publisher on the basis of a non-exclusive transferable worldwide licence unless otherwise agreed in writing prior to first publication. Such submissions are also subject to being used, reproduced, modified, published, edited, translated, distributed and displayed in any media or medium, or any form, format or forum now known or hereafter developed, for any purpose, in perpetuity.

Stock images provided by Shutterstock, Inc



Practical Publishing International Ltd is a member of the PPA

CONTRIBUTORS



Christina Albeck

Christina, founder of Scandi-inspired design house Wardrobe By Me is chatting to us on page 10 about her range of gorgeous patterns. You can try out a pattern for free with Christina's trouser design on page 47!

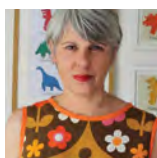

Fiona Hesford

Fiona is the creative brain behind www.sewgirl.co.uk. As a teacher and pattern maker, she loves all things dressmaking, bright and colourful! Her sleepy hot water bottle cover on page 30 would make a perfect gift this Christmas.



Claire Garside

Indie pattern designer Claire shares a classic skirt on page 69 and snuggly sweatshirt on page 93. See the full Simple Sew range and find helpful tutorials and tips at www.simplesewpatterns.com



Cheryl Temple

Cheryl offers a fabulous review of our free McCall's dress on page 23, but you can find out more about her sense of style on her vlog www.youtube.com/stitchybee or visit her new fabric shop www.stitchybee.co.uk

love Sewing loves...

The patterns, people, fabric and finds getting us sewing this month

Join us!



Where: The Refuge, Oxford St, Manchester M60 7HA

When: 10th November, 7.30pm

Price: £25

Further info available at: www.craftstash.co.uk/cocktailhourevent and remember spaces are limited!

Put on your glad rags and join the *Love Sewing* and *Sew Now* teams for a night of fun and excitement. In honour of the Vogue Patterns Cocktail Hour campaign we're giving you the chance to show off your makes with this special evening of cocktails, nibbles, prizes and of course chatter with like-minded sewists. The event takes place on Friday 10th November at The Refuge, in Manchester city centre where we'll showcase the gorgeous garments from the Cocktail Hour collection of patterns and have a huge raffle to raise funds for The Eve Appeal – the only UK national charity raising awareness and funding research into the five gynaecological cancers. Find out more about the fabulous patterns that make up the Cocktail Hour collection at www.sewdirect.com and get your ticket today to join in the adventure.

FRENCH CONNECTION

Sizes: 6-24

Prices: Azara skirt, printed pattern €14, PDF €11 (approximately £12.82, £10) from www.deer-and-doe.com

Remember meeting French pattern house Deer & Doe in issue 40? The dynamic duo is back with its autumn/winter collection of patterns, including plenty to help you build your handmade capsule wardrobe. We especially love the high-waisted, midi-length Azara skirt. Subtly flared, it's a real essential for day and eveningwear and you can choose from an invisible zipper or button-front fastening. Also aimed at the more intermediate sewist is the Bleuet shirtdress, which is an update on a Deer & Doe classic, with an even better fit and a new sleeveless variation. Take a look at the full range for everything from tailored jackets to suede shorts!

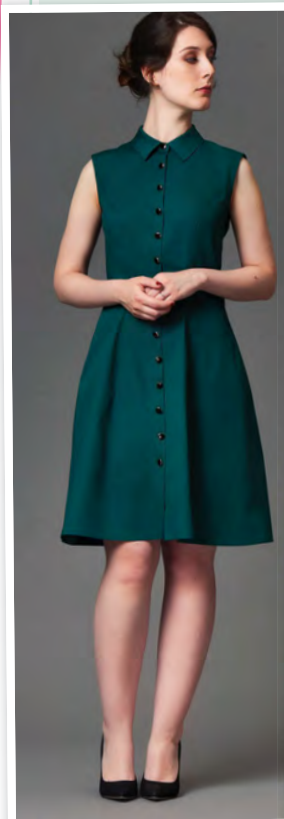

To die for



Price: £179.99 from www.crafterscompanion.co.uk

Paper piecing and cutting motifs for your next project is now even easier thanks to the new Fabric Gemini die-cutting machine. Popular in the world of papercraft, this latest gadget is designed with sewists in mind. It comes equipped with free fabric dies and can be used to cut through multiple layers of fabric at once with precision, saving you a tonne of cutting time! Definitely one for the Christmas list, especially if you consider yourself a patchwork or quilting fan.

50 years of Kaffe

Where: Mottisfont, Hampshire

When: 16th September 2017 – 14th January 2018, 11am-5pm

Price: Adults, £13.60, children £6.80

For more information, go to

www.nationaltrust.org.uk/mottisfont

This autumn, The National Trust's Mottisfont in Hampshire is celebrating over 50 years of world-renowned textile artist Kaffe Fassett. For the first time, over 70 hand-selected designs from Kaffe's personal collection will be on display, in a series of five colour-themed rooms. The 13th century priory will play host to Kaffe's distinctive quilts, knitwear, tapestry and more, as well as a presentation from the man himself.



PRETTY PANELS

Shop: Find your local stockist at www.cloud9fabrics.com

Pre-printed panels are perfect for quick cushions, totes, wall hangings and more, especially when they have such eye-catching motifs on them! The British Invasion collection from Cloud9 Fabrics includes a collaboration with UK designers Eloise Renouf, Jane Foster and Rachel Cave to create three panels, each printed onto a linen-cotton blend. You could even hem it all the way round by 1cm and then by 1cm again to create quick-make tea towel gifts for friends and family.



Price: £19.95

Available from www.oliverbonas.com

Do you know your Bengal from your Russian Blue? Maybe you're not a fan of our doggy free gift this month. Why not grow your arsenal of feline facts and have fun learning about the different breeds and characteristics of your favourite cats with Cat Bingo. Featuring 64 breeds from around the world and beautiful illustrations, this is the perfect game for cosy weekends indoors.

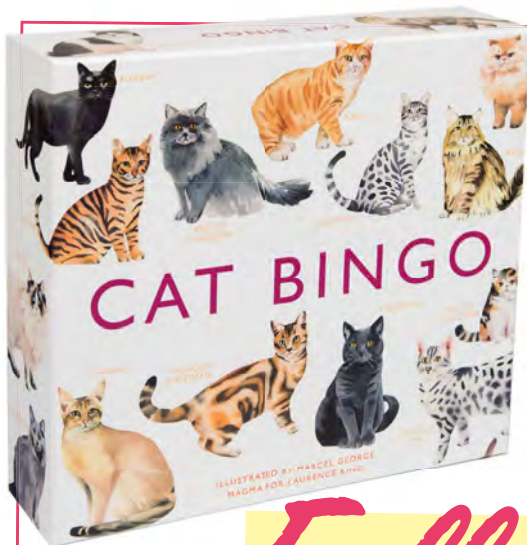

Full house!



Button up

Sizes: 6-24

Price: \$12.99 PDF pattern (approximately £9.96)

The perfect mix of comfort and style, Jennifer Lauren Vintage's Mayberry dress pattern is a must-sew for autumn! It has a gently curved neckline and a striking off-centre button placket, darts to shape the bust and a clever drawstring waist. It includes inset sleeves in three different lengths, making it the ideal layering dress come rain or shine! Designed for confident beginners and beyond, try using a woven fabric with a little drape like a cotton lawn, linen or poplin. For something a little more glam, a slinky rayon or silk will work beautifully too.

MADE TO *measure*

www.free Sewing.org

Finding sewing patterns to fit just got a whole lot easier. Prolific sewist and creative mastermind Joost de Cock has launched a new website that generates sewing patterns based entirely on your measurements. Simply enter your vital statistics, pick your options and a sewing pattern is drafted for you. You can then download it as a PDF or edit it yourself with the source SVG file. Your models and drafts are all stored online and thanks to some very clever open-source coding you can access unlimited women's and men's patterns for free. It's also open to contributions too, if you have a pattern you'd like to share with the world!



Stitchers gonna STITCH

The cross stitch and embroidery we're loving this month



Bethany
Deputy Editor

PAWS FOR THOUGHT

Feeling inspired by the adorable Stanley in his new dog coat on page 53? Display your love for your pooch loud and proud with this bold cross stitch pattern from www.timeforstitch.com.

Available for £4.48 as a digital download, it's designed for 16-count aida and would make a brilliant gift when framed!



RAINBOW BRIGHTS

Stitchers gonna stitch and makers gonna make! This counted cross stitch kit is perfect for injecting some colour into your sewing room and comes with a piece of beautiful hand-painted fabric ready for you to stitch straight onto. The kit includes a chart, black DMC floss, instructions and two gold-plated needles. Available for £25 from www.stitchspiration.com

FLOWER POWER

Practise your French knots, satin stitch, roses and everything in between using this beautiful hoop design from www.tamarny.com. Choose from a full embroidery kit with or without hoop or simply a printed fabric pattern and either display it proudly in your hoop or appliqué it onto a pillow cover or bag. Ideal for building your repertoire of stitches!



EXCLUSIVE READER OFFER!

SAVE
20%

on patterns at
FABRIC HQ
with code LS45



The lovely folks at Fabric HQ are offering a 20% discount on the amazing collection of sewing patterns.

Just go to www.fabrichq.co.uk to find beautiful patterns from brands such as Grainline Studio and Noodlehead and use our exclusive code to save now. Be quick, this offer expires 10th November 2017.



Your wardrobe **YOUR WAY**

We chatted to Christina Albeck, founder of Scandi-inspired pattern house Wardrobe By Me, to find out how she creates instant classics



Hi Christina, tell us what inspired you to start Wardrobe By Me

I discovered the growing interest for home sewing and PDF sewing patterns. Making and selling patterns this way was completely new to me and I was fascinated with the possibilities of reaching people all around the world. I was blown away by the enormous amount of women who felt that high-street clothing just didn't fit right and I thought it would be fun to see if my perspective on well-fitting garments could make a difference.

How would you describe your brand aesthetic to someone who hasn't come across your patterns before?

Wardrobe By Me (WBM) patterns are designed to be the pieces in your wardrobe that you can depend

on, garments that you return to season after season both because of the flattering fit and comfort, but also because of the classic silhouettes that never go out of style.

How do you think your 20 years of experience designing patterns for fashion brands has helped you make your business a success?

The experience helps me create garment patterns that have the right proportions. I know which finish works best with which type of fabric, and I don't need to experiment with pocket placements, button placements, placket widths, sleeve lengths, collar widths etc. That may sound obvious but the right proportions set a garment apart from looking 'right' to looking home cooked. When these things are unbalanced the garment looks wrong. Little details such as what direction the buttonholes should be placed on a placket (vertical), or the direction of a striped waistband (horizontal) on a pair of striped pants, make all the difference. I design patterns with the sole purpose of making something that fits well and is flattering.

How do you take an idea and turn it into a pattern?

I sketch the design, and develop the pattern using PAD-system (apparel software for pattern making and grading). Then I plot the pattern and sew a prototype that I fit, check for balance, proportions and ease. I decide if the design invites any 'natural' variations, and incorporate those into the final pattern. Next I lay out the pattern pieces, write instructions, and open the pattern for testing. I test it over about 10 days, and usually have 15-20



Try Christina's
ponte trouser
pattern on
page 47

ABOUT *Christina*



Christina is the owner and designer at Wardrobe By Me, where she creates Scandinavian-inspired PDF sewing patterns with a classic yet contemporary aesthetic. To find out more about the brand, visit www.wardrobebyme.com. Follow the Wardrobe by Me community and sign up to become a pattern tester at www.facebook.com/wardrobebyme



Diana Wrap Dress



Bestseller, the Asta Jersey Dress

talented ladies help me check the fit and edit the instructions. Testers have very valuable input, and I always listen to their feedback. Finally the pattern is released. This process takes around four weeks from initial idea to final release.

What's your favourite part of your job?

I love posting tester calls because at that point all the hard work is behind me, and all I have to do is polish and correct mistakes! I love seeing how testers make the pattern their own and watching them develop and blossom to be really great at modeling and showing off their makes.

What patterns are proving to be the most popular?

The top-selling WBM dress pattern is the Asta jersey dress. I developed the pattern several months before testing. I felt the silhouette was too simple to even bother, but on a whim I decided to test it anyways. When I made the tester call in my Facebook group, more than 100 people applied to participate, which was a complete surprise! When the pattern was released it generated an all-time high both in terms of visits but also sales. Wrap dresses like Diana and Mirri are the top sellers. Not upon

release, but over time. Those two are no surprise to me, as wrap dresses are very flattering, easy to sew and never out of style. The men's patterns also generate a lot of interest. That has come as a surprise, but I think all seamstresses really enjoy being able to make something homemade for the men in their life.

How do you think Scandinavian style differs from British style?

Scandinavian style tends to be quite simple and casual. We are not great fans of elaborate and brightly coloured floral prints. We tend to gravitate towards blue, grey, brown and black colours. Aside from this, British and Scandinavian style is very similar.

Finally, what are you working on over the next few months?

The original goal for WBM was a full collection of patterns to fill all wardrobe needs. At this point we are almost there. Over the next few months I will be focusing on making more patterns for wovens. We all love a great jersey top or dress, but a woven project is a great way to improve your skills and really add finesse to a home-sewn wardrobe. Additionally I would like to expand the men's collection and to include a collection of lounge and sleepwear.



Mirri Wrap Dress

MACHINE REVIEW

This month we take a look at Janome's sewing machines with options for every budget

BEST FOR LIGHT-HEARTED SEWING

J3-180

If you're new to sewing or just want to sew for the pure enjoyment that it brings without spending a fortune on a machine, the J3-180 is the one for you. An excellent starter machine that is also perfect for those that sew occasionally, the J3-180 is a really easy-to-use machine with two dials, one for stitch selection and another for adjusting stitch length. The automatic four-step buttonhole feature creates a lovely finish and the automatic needle threader takes the strain (and frustration) out of threading the needle.



Leanne



UNDER
£170



UNDER
£400

BEST FOR HIGH-TECH OPTIONS

ATELIER 5

Janome's latest computerised sewing machine has been designed to meet every sewing challenge. It is so versatile that there are three optional kits available, one for quilting, one for home furnishings and a third for fashion sewing. With a total arm length of 310mm (over 12") and 210mm (8³/₁₆") arm space right of the needle, this machine is ideal for bigger projects and yet is equally suited to precision sewing with an incredible 91 needle positions. It has a superior feeding system and an easy-change needle plate to enhance straight stitch performance at up to 1,000 stitches per minute! You can save your stitches with the built-in memory function, allowing you to get started on your projects straight away.



Amy



FROM
£1,000

BEST FOR EASY-TO-USE FEATURES

230DC

The Janome 230DC brings upgraded technology to a simple and easy-to-use machine. It's fully computerised with stitches and settings at the touch of a button and allows simple, no-fuss threading with the auto threader and quick-set bobbin. Light enough to carry to classes, the 230DC has plenty of stitch options for all kinds of projects and lots of easy-to-use features to make sewing a pleasure. It is the machine to grow with your skills and is suitable for beginners and more experienced sewists.



Bethany



Introducing the Fold Away Petite - Dunster Edition small but perfectly formed! With a small footprint when closed and a folding work table there is a spacious work area and plenty of storage.

fold away Petite

Dunster Edition



- § Folding desk offering a generous work space
- § Choice of storage racks to keep supplies
- § Cable access to enable integrated power
- § Optional built in lighting pack

Regular Price £995
(excluding delivery and lighting kit)

Magazine Offer
£850 (SAVE £145)

Mainland UK delivery £35 extra
Optional lighting kit £50 extra
Offer Coupon - DUN715



Unit pictured in Vanilla finish

Specially designed with the quilter in mind

Choose options to suit you

fold away Deluxe

Watersmeet Edition

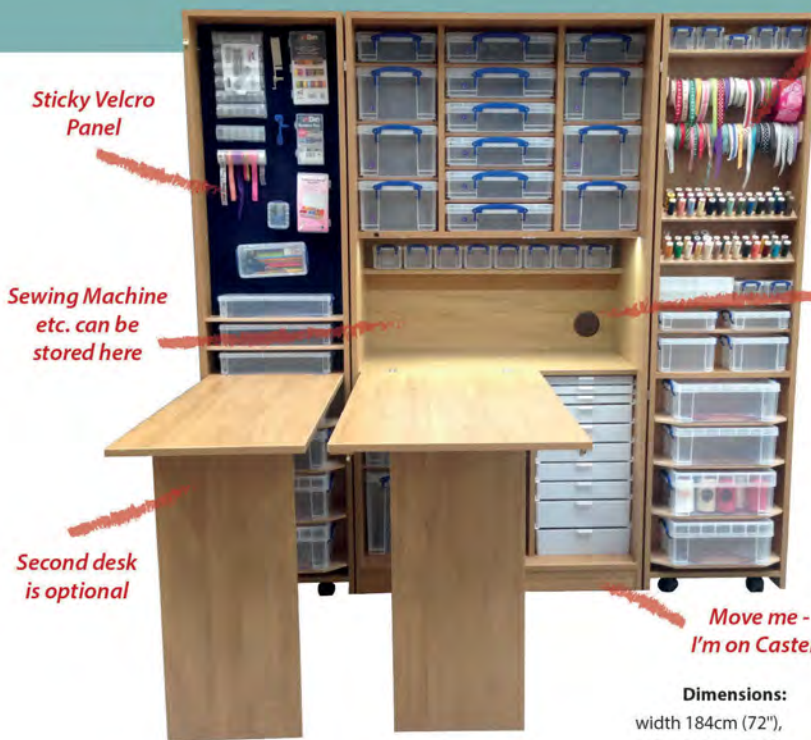

Sticky Velcro Panel

Sewing Machine etc. can be stored here

Second desk is optional

Move me - I'm on Casters!

Dimensions:

width 184cm (72"),
depth 50cm (20")

with desk folded up, depth 150cm (59")
with desk(s) in use, height 183cm (72")

Unit pictured in Oak finish

Finished Crafting...
Then just Fold Away to a unit which is barely larger than a standard double wardrobe

Add Power - Cable Access here

Fold Away Deluxe - Watersmeet

Regular Price £1495
(excluding delivery and lighting kit)

Magazine Offer
£1195 (SAVE £300)

Mainland UK delivery £50 extra
Optional lighting kit £50 extra
Offer Coupon - WM715



width 92cm (36"),
depth 65cm (25 1/2"),
height 183cm (72")

Ribbons

Threads

Lighting



Please note all furniture items are supplied self assembly - assembly can be arranged please call for further details and charges

www.storage4crafts.co.uk

mail@storage4crafts.co.uk

Call us free
0800 048 8606

Offers expire end of month following magazine publication
(eg. Jan Issue expires end of Feb)

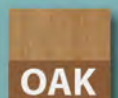



Fun fact!

In the UK, 47% of men sleep in absolutely nothing but only 17% of British women go to bed nude

A brief history of **PYJAMAS**

Sit back and relax while we share with you the origins of the essential pyjama

Have you ever wondered why you gravitate towards a certain style of sleepwear? Do you prefer a silk nightdress, cotton stripe pyjama set or perhaps like Marilyn Monroe you sleep in nothing but Chanel No.5?

The word 'pajamas' originates from the Hindustani word 'epai-jaima'. These were adaptations of harem pants popularised in Asia, introduced to Europe in the 17th and 18th centuries, and were mostly popular among men. British colonists admired this casual style and by the 1870s they had adopted these roomy trousers as comfortable loungewear and, later, as sleepwear.

India was to become the greatest exporter of textiles the world had ever known, with the trade reaching its height in the 18th and 19th centuries. There are many other Indian words still in English usage, which reflect this period of massive trade in textiles. For example, calico, dungarees, gingham, khaki, sash, seersucker and shawl all originated during this time.

By definition, the term referred only to trousers. It wasn't until the 20th century that pyjamas became associated with a co-ordinated comfortable ensemble and over the years the word has become interchangeable with any kind of sleepwear. It took quite a while for women to take notice and adopt the fashion. Lingering Victorian purism meant it was unseemly for a woman to reveal the shape of

her figure with her nightwear. But when Coco Chanel introduced a line of attractive lounging and beachwear pyjamas in the 1920s it began to persuade women that pyjamas could be as flattering as a traditional nightdress. A chic beach set on display

in the Victoria and Albert museum features a wrap jacket and wide-legged palazzo pants in pale pink cotton with black lapels, cuffs and accents and attached front belt fastening with a plastic buckle.

Christian Dior wanted a woman to look and feel glamorous, whether out on the town or retiring to her bed

Nightwear began to reflect the dress styles of the day. Out went the full-length puritan white gown and in came the wide-leg trousers, lace-trimmed tops and short negligé that became a bedroom version of a fashionable 'flapper' dress. Most women's pyjamas were made of flowing fabric such as silk, satin, chiffon, or rayon. They featured loose, ankle-length trousers that hung straight at the bottom or were drawn tight around the ankle by a ribbon or lacing. The waistlines of the trousers had drawstrings. Tops were hip-length jackets with varying sleeve lengths. Men now almost exclusively wore pyjamas, in cotton twill, calico and flannelette and decorated with pale stripes – still the most popular style today. But they also had quilted bed jackets and smoking jackets in plush velvet and silk.

After World War II ended, production and consumerism began to resurface and nightwear was not only given a new life, but a new perspective.



A chic beach set on display in the Victoria and Albert museum features a wrap jacket and wide-legged palazzo pants in pale pink cotton with black lapels, cuffs and accents



©Victoria and Albert Museum, London

French fashion designer Christian Dior went on a mission was to make a woman 'feel like a duchess', whether she was rich or poor. He made beautiful long satin gowns with lace trim and exquisite embroidery that were tailored to rest lightly on the curves. Dior spoke of his mission to make all women look and feel glamorous, whether out on the town or retiring to her bed. The 1960s was when real experimentation began as nightgowns were replaced with short babydolls and were designed with matching lingerie as a sexier alternative.

Footsie pyjamas have a reputation for being created for children but they were actually made when people began sewing socks to the bottom of their pajamas to prevent bugs like termites from nibbling on their toes. Now the trend for wearing an all-in-one lounge suit is more fashion focused with novelty fabric and designs being highly sought after for children and young-at-heart adults. Several sewing patterns have also sprung into the market to satisfy demand for this trend.

Today, it's seemingly acceptable to run quick daytime errands while wearing night-time attire. While we don't suggest you take the kids to school in your lace nightie, why not try a silk or viscose pyjama top as an elegant blouse?



Why not try a silk or viscose pyjama top as an elegant blouse?



Closet Case Patterns Carolyn pyjamas offer a modern take, see www.hantex.co.uk/mystockist



We love the version of Kwik Sew 3553 from issue 10 of our sister mag Sew Now

Everyone deserves a **Fashion Mate**

Introducing the new **Singer Fashion Mate** machines

The **Singer 3333, 3337 and 3342 Fashion Mate** include:

- * Up to 32 Built-In Stitches
- * 1-Step & 4-Step Buttonholes
- * Built-in needle threader
- * Top drop-in bobbin
- * STAYBRIGHT™ LED Light
- * Adjustable Stitch Length
- * Heavy Duty Metal Frame
- * Free arm
- * On-board storage
- * A range of free accessories

PRICE
FROM
£169



Machine pictured is the SINGER® FASHION MATE™ 3337.



SINGER®

The world's favourite sewing machines

Join us on [Facebook](#), [Instagram](#) and [Twitter](#) @singersewinguk

www.singerco.co.uk

A woman with blonde hair, wearing a black and gold leopard print dress and red high-heeled sandals, is smiling and holding a gold streamer. To her left is a large clear balloon filled with gold confetti. The background is a white paneled wall, and the floor is covered in gold confetti.

That's a **WRAP**

With six styles to try and a bonus pattern hack, you won't know where to start with this amazing staple pattern. Don't forget, McCall's patterns come with foolproof step-by-step guides to make sewing a breeze!

VIEW A & B

We paired the gorgeous bodice of view A with and the longer sleeve length of view B. We think it's the perfect combination!

We used:

Black & gold animal-print jersey, £4.50 per metre
www.sherwoodsfabrics.co.uk

McCALL'S®

Your free
GIFT



VIEW B

Be still my heart! This view is the classic wrap silhouette but the faux wrap front means your dress won't come undone! Thinner viscose jersey will work but you may want to wear a slip for added coverage.

We used

Black vintage hearts on red viscose jersey, £9.95 per metre
www.girlcharlee.co.uk



Subscribe today to get a
McCALL PATTERN CO. DESIGN IN YOUR SIZE WITH EVERY ISSUE!

See page 26 for details



Save 20%

The lovely team at Fabrics For Sale is offering 20% off at www.fabricsforsale.co.uk with the code LOVESEW25 until 30th November

VIEW C

Made in bright ponte roma, this dress looks glamorous but feels like you're wearing secret pyjamas!

We used

Red cotton ponte, £8 per metre
www.fabricsforsale.co.uk

MASTERCLASS STITCH SUCCESS

Here is our cheat sheet of stitch settings to get a fantastic finish on your free pattern gift

LIGHTNING BOLT STITCH (NO. 11 ON BELOW IMAGE)

This clever variation on a zigzag is a neater alternative. It reduces puckering on lightweight or very stretchy knit fabric and bias seams, while permitting the seam to be pressed completely flat. It's so called due to its lightning shape and has a narrow width of 2.0 and a length of 2.5. Be wary that this stitch can be extremely hard to unpick so being confident with your sewing is key.

OVEREDGE OR OVERCAST FOOT AND STITCH (NO. 9 ON BELOW IMAGE)

If you don't have an overlocker at home you can replicate the robust stitch it creates with a special foot and stitch setting. The guide on the foot runs along the side of the fabric and a little brush spreads out the thread as you sew to cover the raw edge. You can also adjust the width you need, choosing a wider stitch for thicker fabric. It is a slightly slow process as the needle must stitch multiple times before moving on so patience is key with this finish.

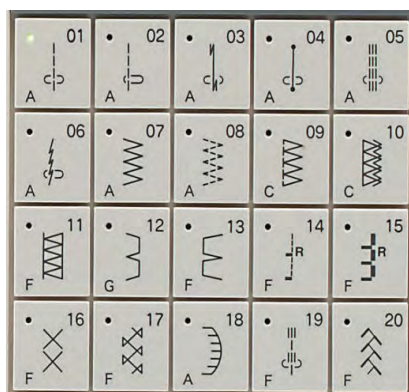

Remember the finished measurements are printed on the pattern tissue! This helps you pick the perfect size

Amy says...



TRIPLE STRAIGHT STITCH (NO.5 ON BELOW LEFT IMAGE)

This tough stitch is formed when the machine's feed dogs move the fabric forward and then backward while the machine sews a straight stitch. The forward-backward movement gives stretch but the multiple lines of stitching provide the durability. Use this stitch at points of stress, such as armholes, for a long lasting finish. This process isn't ideal for lightweight knits that may ripple or pucker but the results are great for durable knit garments that will have a lot of wear.

TWIN NEEDLE

Using two spools of thread and a regular straight stitch, you can create a stretchy topstitch that mimics the effect of a coverpro machine. Your bobbin thread will zigzag behind the two stitching lines on the RS, creating a polished look inside and out.



Win!

Enter our competition on page 73



lisette

SEW YOUR STYLE



B6482

Available from fabric stores
and websites countrywide.
Or visit www.sewdirect.com

Lisette:
Sew
Your Style!

Butterick®

Reader Review

McCall's 6884

Cheryl of vlog www.youtube.com/stitchybee shares her thoughts on this issue's **McCall's free gift**



The wrap dress is a classic dress for good reason – it flatters every figure and this pattern is no exception. M6884 comes in four

variations, with sleeve and dress length choices. I chose to make view C, which has a three-quarter sleeve and gathers across the waist area. Like many ladies, I like a bit of coverage around the tummy and view C ticks the box for this!

I chose a super-soft ponte roma called Miss Monochrome from my online fabric shop www.stitchybee.co.uk at just £4 per half metre. A dress for autumn in this lovely monochrome fabric is just perfect for taking me from day to night. Ponte roma adds more structure than a standard jersey would, and this is helpful in adding stability to fitted dresses.

The pattern itself is very simple to cut, making it ideal for beginners wishing to try their hand at sewing stretch fabric as well as seasoned sewists expanding their handmade wardrobe. Take care when reading the layplans; it's critical that the fabric is cut exactly as the instructions state, in the correct direction with the pattern pieces face down or face up as instructed. Because the fronts are different, it's important to make sure the left

and right pieces are facing the correct way.

Sewing the ponte roma was a dream. The neckline and hems lie nice and flat with minimal pressing required (just take care not to stretch the fabric too much as you sew). When sewing knits I always use a fresh sewing machine needle to help me get the perfect finish.

When it comes to fit, the dress is true to size (I sewed a 14); I just made my usual adjustment by lengthening the waist by 1". The best thing about this particular wrap dress is that the under part of the front is sewn in, giving confidence when wearing it. The dress still ties though, just adding to the great fit.

I'm really pleased with how my version of the M6884 turned out, and I already have plans to make more. Thank you *Love Sewing*, this has been a great project and quick to make over just two evenings.



In issue 46, Sue reviews **M7322 & B6461**



Check out Cheryl's new online shop at www.stitchybee.co.uk

FABRIC FOCUS



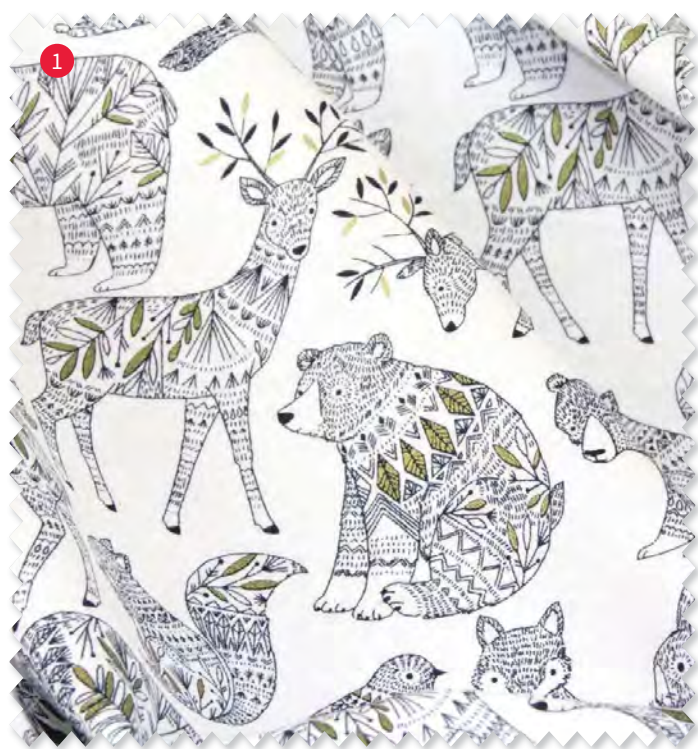

Deck the HALLS

We've rounded up our favourite festive fabric you can use to brighten your home this Christmas

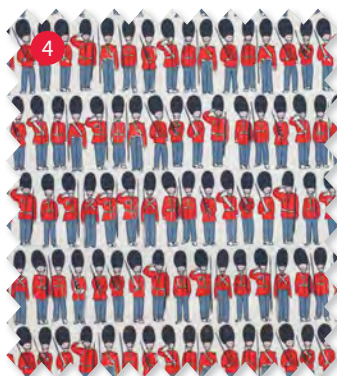

Fabric shopping

- 1 Geo animals in white gold cotton, £14 per metre www.mauds-fabric-finds.com 2 Check Yo'self in Holly Berry Tula Pink cotton, £3.75 per FQ www.simplysolids.co.uk 3 Baubles MERR 1221 Dashwood Studio cotton, £11.49 per metre www.doughtyonline.co.uk 4 Guards cotton duck, £20 per metre www.cathkidston.com 5 Shamrock Cirrus solids cotton Cloud9 Fabrics (C9CS958), see www.hantex.co.uk/mystockist for your local retailer 6 Red on cream Nordic Snowflake Makower, £11.99 per metre www.doughtyonline.co.uk 7 Garland Merry Merry in ribbon cotton by Kate Spain for Moda, £3.30 per FQ www.eclecticmaker.co.uk 8 Little Friends MERR 1223 Dashwood Studio cotton, £11.49 per metre www.doughtyonline.co.uk

Yes! I would like to subscribe to *love Sewing* and receive my **FREE** copy of *Sewing Your Perfect Capsule Wardrobe!*

Please complete in ballpoint pen and send to:
Love Sewing, Tower House, Sovereign Park,
Market Harborough, Leicestershire LE16 9EF

Quote code:
PLSE1017

Your details

TITLE: FORENAME:.....
SURNAME:.....
ADDRESS:.....
..... POSTCODE:.....
DAYTIME TELEPHONE:.....
MOBILE TELEPHONE:.....
EMAIL:.....

To give a subscription as a gift, please complete the section above and supply the recipient's address details on a separate sheet.

DIRECT DEBIT @ £24.99 EVERY 6 MONTHS BEST PRICE!

Instruction to your Bank or Building Society to pay by Direct Debit



Name and full postal address of your Bank or Building Society:

To: The Manager Bank/Building Society
Address
.....
.....
Postcode

Name(s) of Account Holder(s)

.....

Branch sort code

□ □ □ □ □ □

Bank/Building Society account number

□ □ □ □ □ □ □ □ □ □ □ □

Office use only

Reference

Originator's Identification Number 4 3 9 3 4 5

Signature

Date

Please pay Practical Publishing Int Ltd Direct Debits from the account detailed in this instruction subject to safeguards assured by the Direct Debit Guarantee. I understand that this instruction may remain with Practical Publishing Int Ltd and, if so, details will be passed electronically to my Bank/Building society.
Bank and Building Societies may not accept Direct Debit instructions for some accounts.

13 ISSUES FOR £51.99 – CHEQUE/ POSTAL ORDER/ DEBIT/CREDIT CARD

I enclose a cheque/postal order made payable to Practical Publishing International Ltd OR please debit my Visa/Mastercard/Maestro (delete as appropriate)

CARD NUMBER

□ □ □ □ □ □ □ □ □ □ □ □ □ □ □ □

EXPIRY DATE

□ □ □ □ □ □

ISSUE NUMBER (if Maestro)

□ □ □ □ □ □

SIGNATURE:..... DATE:.....

*UK offer only. Minimum subscription term is 12 months, we reserve the right to request the gift is returned should the subscription be cancelled early. Subscriptions start with the next available issue. We reserve the right to send an alternative gift should *Sewing Your Perfect Capsule Wardrobe* become unavailable. For overseas rates and other payment methods, please visit www.moremag.com/subscriptions. Hurry this offer expires 02/11/2017.

I DO NOT want Practical Publishing Int Ltd to contact me by email telephone post
 Tick this box if you do not wish to receive promotional material from carefully selected third-party companies

Love Sewing is packed with tips, tricks and clever ideas to keep you inspired month after month. Every issue includes a stunning free paper pattern from The McCall Pattern Company, the best tutorials from industry experts plus exciting projects and inspiring articles.

Whether you're making unique garments, chic homeware and accessories, or fun embroidery projects, *Love Sewing* is the perfect addition to your sewing room.



Exclusive designs from
The McCall Pattern Company
with every issue

10 REASONS TO SUBSCRIBE:

- 1 **SAVE** money on every issue
- 2 **FREE** delivery direct to your door
- 3 **NEVER** miss an issue
- 4 **BE THE FIRST** to read *Love Sewing*
- 5 **FREE** pattern worth over £8 from The McCall Pattern company with every issue
- 6 Exclusive promise to offer **BRANDED PATTERNS** in the widest size range
- 7 The **BEST** tutorials and projects from industry experts including Wendy Gardiner and Alison Smith MBE
- 8 **BUILD** your ultimate pattern collection
- 9 **NEVER** be short of sewing inspiration again
- 10 **SPREAD** the **COST** with a Direct Debit

FREE SEWING YOUR PERFECT CAPSULE WARDROBE BOOK

When you subscribe to

love
Sewing*



Subscribe to *Love Sewing* and receive your very own *Sewing Your Perfect Capsule Wardrobe* book! In this beautiful book, containing full-size pull-out patterns, dressmaker Arianna Cadwallader and designer Cathy McKinnon present instructions for five key pieces: a jersey vest, an elegant skirt, a simple blouse, contemporary trousers and a classic shift dress.

The focus is on getting a great fit and all the patterns can be adapted to suit you perfectly, whether you prefer long, short or cap sleeves, a high or low waistline, or slim, straight or wide-legged trousers. Aimed at advanced beginners, the book guides you through every step you need for an easy and effortless style.

Subscribe for just £24.99 every six months by Direct Debit!



Ordering is quick and easy...

Online: www.practicalsubs.com/2401

Call: 01858 438899 (QUOTE CODE: PLSE1017)



With Elisalex

The Dressmaker's DIARY

*Sew a clever T-shirt hack inspired by
The Refashioners with this easy tutorial!*

In case you've been living under a rock recently, refashioning is back in a big way. I don't mean safety pins and tie dye, beaded knots and mod podge (although that will always be cool to my inner tween), we're talking some seriously sophisticated refashioning. The kind of thing you'd expect walking the runway at Jean Paul Gaultier – and if his autumn 2017 show was anything to go by, it seems Mr JPG himself must have somehow got wind of this year's official Refashioners theme, Suits You!

Masterminded by Portia Lawrie of www.makery.uk back in 2011, The Refashioners aims to inspire sewists to see refashioning and upcycling in a new light. What started as a small blog series has now exploded into an annual global challenge calling upon sewists the world over to dig out their unloved, unworn, moth-eaten garments and re-imagine them into something fresh and new. This year's theme is #suitsyou – so head to your local charity shop, get hacking and share your creations on Instagram at [therefashioners2017](https://www.instagram.com/therefashioners2017). Did someone say "monster prizes"?

Now, I'm certainly not claiming to be of Jean Paul Gaultier's calibre when it comes to refashioning, but I do find a huge amount of satisfaction in



Get involved

Follow
[#therefashioners2017](https://www.instagram.com/therefashioners2017)
for oodles of inspiration
and visit www.makery.uk
to find out more

being able to see beyond the seams and breathe a new lease of life into otherwise discarded garments. This tutorial will show you how simple it can be to completely transform one of the most common things you will find in a charity shop – the oversized T-shirt. And in doing so, you can open up a whole world of possibility and imagination...

MATERIALS & TOOLS:

- oversized secondhand T-shirt
- T-shirt that already fits you well for reference
- usual sewing supplies

HOW TO MAKE:

1 Lie your T-shirt flat and cut horizontally across where you want the seam to be. Put the bottom half aside.



2 Turn the T-shirt inside out and use an existing T-shirt of yours that fits to draw out a new armhole and side seam.



3 Fold the T-shirt in half lengthways so that you can cut each side identically.

4 Cut away the excess bodice from the sleeves you cut off, unpick the hem and underarm seam and press the sleeve flat. Cut right down the middle of the sleeve.



5 We're now going to re-attach the sleeves to the new armhole. With the T-shirt flat and right side up, pin the sleeve into place, overlapping the two cut sides of the sleeve head. Sew into place and repeat for the other sleeve – make sure that you overlap the same side each side! You can sew the seams on a regular sewing machine with a shallow zigzag stitch, or on an overlocker if you have one.

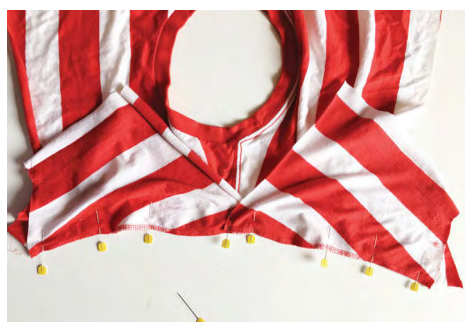

6 With right sides together, sew the new underarm and side seam in one fell swoop, doing your best to match the underarm intersection.

7 Take the bottom half of the original T-shirt that you cut away at the start. Unpick the hem, press and cut in half along the width. Cut the side seams (so that you now have two long strips made up of two fronts and two backs) and discard one front or back section so that you have three panels that you can then sew together to form one long continuous loop.

8 Run two rows of parallel basting stitches along the top, back stitching at one end but not the other.

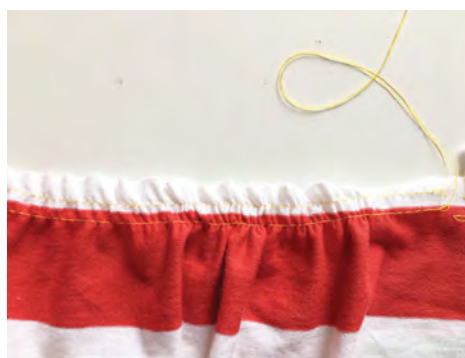

Pulling gently on the un-backstitched bobbin threads, gather the loop until it is the same circumference as the waistline of the T-shirt.

9 With right sides together, join the gathered panel to the T-shirt's waistline.

10 Finish by hemming your new top (or not if you prefer to leave it raw like I did), tying the open ends of the sleeves into little knots.

Top tip!

Make sure you have the right needle for your sewing machine! Ballpoint needles are best for sewing with knits



ABOUT ELISALEX

Elisalex de Castro Peake is the head of design and co-founder of By Hand London. An independent pattern company, it produces gorgeously designed, high-quality patterns that are available as PDF downloads through the site www.byhandlondon.com

Some like it **HOT**

MATERIALS & TOOLS:

- 2 30x40cm pieces of flesh colour felt
- 2 30x40cm pieces lightweight wadding (Vlieseline Thermolam 272 Compressed Fleece)
- 2 30x25cm pieces floral printed cotton (fuse interfacing to the reverse side of both)
- 30x25cm lightweight fusible interfacing
- 50cm 10-15mm-wide ribbon
- black embroidery floss
- medium & pink felt scraps for (cheeks) & (lips)
- 15x10cm bonding web
- co-ordinating topstitching thread
- tacking thread
- 1cm button (optional)
- air-erasable fabric marker
- buttonhole foot (optional)
- templates downloaded from www.lovesewingmag.co.uk

CUTTING:

Using your templates, cut the following pieces:

- 1 front in flesh-coloured felt and one in wadding
- 1 hair in floral cotton fabric (interfaced)
- 1 upper back in floral fabric (interfaced) and one in wadding
- 1 lower back in flesh-coloured felt and one in wadding
- 2 cheeks and one lips from pink felt

NOTES:

Seam allowance of 1cm is included except where otherwise stated

HOW TO MAKE:

1 Lay the wadding and felt front pieces together on a table. Lay the front hair piece on top of the felt piece in position, aligning the raw edges. Pin then tack all around. Zigzag-stitch on top of the two curved hairline edges. Adjust the zigzag setting to a medium width and small length and take

Snuggle up as the cold weather approaches with this Sleepy Sally hot water bottle cover

Project **FIONA HESFORD** Sewgirl





Bethany says...

This lovely lady would make a good Christmas gift, and a great stash buster!

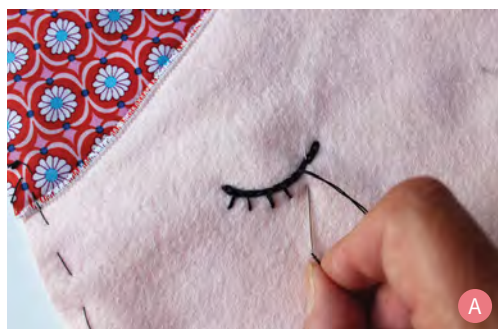

care to cover the raw edge (thread that co-ordinates with the flesh-coloured felt is best).

- 2 Using an erasable marker, draw two curved lines for the eyes using the template as a guide.
- 3 Hand-sew a chain stitch line with black embroidery thread along these marked lines, then make stitches for eyelashes. Pass the thread to the reverse of the fabric and secure before trimming. Press. (See Pic A.)
- 4 Trace one lip shape and two cheeks onto bonding web. Fuse to the respective felt pieces. Cut out, peel off the backing and place in position. Press to fix. Machine-stitch carefully around each shape close to the edge with a straight stitch setting. (See Pic B.) You can always hand-stitch these bits if you prefer!

- 5 Lay the wadding and floral fabric Upper Back pieces WST on a table. Tack-stitch around the edges except for a long straight edge. Finish the straight edge with a zigzag stitch or overlocker then make a 1cm single-fold hem at this edge.
- 6 Lay the felt and wadding Lower Back pieces WST on a table. Tack-stitch around the edges and make a simple hem as before along the long straight edge.

Top tip
 Forget special machine feet or tools, you can hand-sew the whole thing if you prefer!

- 7 Make a buttonhole, if desired, at the centre of the Upper Back close to the hem.
- 8 Pin a strip of ribbon across the narrow section of hair on the front and back. Machine-stitch.
- 9 Place the assembled Front on the table with RS facing up.
- 10 Lay the Upper Back piece RS facing down on the top of the front piece.
- 11 Place the Lower Back piece RS facing down with straight hemmed edges overlapping by 3cm.
- 12 Pin all around the edges and tack-stitch in place to stop the felt moving as you sew.
- 13 Sew with a 1cm seam allowance all around the hot water bottle, lengthening the stitch setting a little to make sewing multiple layers easier. Remove the tacking.
- 14 Notch the curved seam allowances. (See Pic C.) Trim across the corners then turn the hot water bottle case inside out, pushing out the corners. Press.
- 15 Sew on a button at the back to match the buttonhole. Hand-stitch on a ribbon bow to finish.

EXCLUSIVE COMPETITION!

Win!
90

90th
anniversary
Simplicity
Since 1927
patterns!

To celebrate Simplicity's 90th anniversary we've got an exclusive competition to win an incredible 90 patterns!

The Dottie Angel Simplicity Misses' 8298 coat and jacket pattern features hood or mandarin collar variations, a range of pockets and quirky contrasting elbow patches. Keep an eye out for double-faced pre-quilted fabric to make this autumnal jacket extra cosy!



EXCLUSIVE COMPETITION!



TO ENTER, GO TO WWW.PPJUMP.COM/LOVESEWING45

*Competition closes 9th November 2017. Winners will be notified by email.
Competition only open to UK residents. Additional patterns to those listed above will be selected by Simplicity.

**HABERDASHERY
PATTERNS
FABRIC**

Fabric
X
GODMOTHER

WWW.FABRICGODMOTHER.COM

BECCLES SEWING & HANDICRAFTS

DRESSMAKING & CRAFT FABRICS,
HABERDASHERY & CRAFT REQUIREMENTS
SEWING MACHINES REPAIRS & SALES

Authorised dealer for:
JANOME, BROTHER, BABYLOCK, SILVER, ELNA, SINGER,
JUKI, ALFA & FRISTER+ROSSMANN.

ISA, Blyburgate, Beccles, Suffolk NR34 9TB
01502 714234

Caffle Crafts (01934) 838327

Family run shop with
patchwork fabrics, embroidery
threads and sales agents for
Brother sewing and
embroidery machines with
extensive after sales support.

2 miles from J21 M5 www.cafflecrafts.co.uk
BS24 6SE tina@caffle.co.uk

www.sewingbelle.co.uk

Our website offers a full range of sewing patterns including Simple Sew,
Vogue, Butterick, Kwik Sew, Tilly and the Buttons, Simplicity,
New Look, McCall's & Burda

25% off your order quote SB25

McCALLS Butterick TOM AND LINDA PLATT

Chrysalis
FABRICS.co.uk

Sign up now to receive
four seasonal swatch Collections
and access to our entire range
of premium quality dress fabrics.

Call Diana on 07748 530 318
or visit our website

SEQUINS!

Your work deserves the best.

Sequins - Paillettes - Sequin Trim

Specializing in high quality sequins.

Sequins from 3mm - 150mm!

Incredible selection of unique colours, sizes,
finishes and shapes.

FREE worldwide shipping

www.SequinsUSA.com

The cocktail hour SEW-ALONG

Follow the fabulous blogger tour, chat with your favourite sewists and see pattern reviews at www.thefoldline.com/blog



Have you joined in with The Cocktail Hour yet? It's a fun opportunity for sewists to come together and 'sip and sew'! We're thrilled to have Rachel and Kate from The Fold Line to share all the news from the fun blogger tour. So, who's been sewing some DIY glamour this month?



Abigail Norton

Sew Abigail

Abigail chose to make Vogue 1471, which is a lined lace dress with fitted bodice and plunging V neck. The dress also has a hem ruffle and exposed zipper. Abigail hadn't sewn with lace before but wanted to challenge herself with this make. She followed the instructions closely and didn't make any changes to the pattern.

After struggling to find some lace that was wide enough, as most is designed for lingerie, she chose this gorgeous red scallop-edged lace. There are quite a few pattern pieces with this dress because of the multiple layers so it isn't a quick make but, as we can see from Abigail's amazing dress, it is so worth the effort! She looks stunning and what a cocktail dress this is!

www.sewabigail.co.uk/2017/08/18/painting-the-town-red-2017-cocktail-hour

Karen Ball

Did You Make That?

Karen decided to make Vogue 1537, which includes a dress as well as a full-length coat with princess seams at the front and back with deep patch pockets and button-up front. Karen chose to make the coat, which for anyone who has made a coat before, will know it's not a quick process! She spent three weeks making her coat and liked the Jackie Kennedy style it has.

The fabric pieces need to be interfaced and in addition to this Karen also used a number of other techniques to make the coat, including prick stitching the collar and pockets plus adding shoulder pads, sleeve head rolls and a back stay. You can find tips for all these techniques on her blog. All the effort, including the five hours of hand stitching, was worth it because the coat is brilliant and has a great fit. It would easily take you from the office to a night out.

www.didyumakethat.com/2017/09/01/the-cocktail-hour-sewalong-v1537

ABOUT THE COCKTAIL HOUR

In March, The McCall Pattern Company in the UK chose 20 of its most popular Vogue patterns perfect for wearing while sipping cocktails. A contribution from every pattern sold in the inspirational edit will go towards supporting The Eve Appeal charity. Find out how to take part, plus read all about upcoming events at www.sewdirect.com

Turn to page 6 to find out how you can join Love Sewing for our Cocktail Hour celebration!



ASK THE EXPERTS

THRIFTY STITCHER

This month Claire-Louise Hardie shows how to calculate fabric quantities when you don't have a pattern to hand

I am often asked by my students how much fabric they should buy when they fall in love with a design but don't have a pattern in mind. We've all been seduced by that gorgeous cloth when we weren't planning to shop and didn't come prepared. And with self-drafting becoming more popular, you may not even have a handy fabric quantity chart to refer to at all.

There are a few approaches to solving this conundrum! One school of thought is to only ever buy three metres, that way you're covered for most projects. It's a great plan if inspiration strikes when shopping at a market stall, less brilliant if you're in Liberty and don't want to max out your credit card!

Personally I'd take a second and have a good look at the hand and drape of the fabric, as this will often determine what it's suitable for and therefore what kind of garment I can make. If it's a super lightweight Tana lawn for example it's probably best used for a top or a blouse, rather than trousers.

Woollen fabric works really well in tailored pieces, so could become a jacket, skirt or trousers, all needing a little more fabric than a top. Heavier cloth like denim, drill or canvas would be better suited to structured garments like jeans, coats and some skirts.

Top tip!

Many pattern companies create layplans that are easy for beginners to follow rather than being economical

Sheer fabric works really well for clothes with a little volume like gathered details, so you may need a lot more fabric.

One tip that could be very useful when you're out and about is to keep photographs of the back of some of your favourite pattern envelopes on your phone and use the fabric quantities suggested. If you have some tried and true (TNT) patterns that suit your own style, it's likely

you'll be looking to make similar pieces. I love a shift dress so having a picture of the back of my favourite pattern to hand means I can quickly see what sort of quantities I'd need for common fabric widths.

I'm also a big fan of keeping a note of how much I use when making up a project. Since I always do a rough tissue fit, I adjust the length on the paper pattern first. This allows me to be able to measure the fabric as I cut out,



The *Maker's Workbook* planner, £12.50 available from www.creative-industry.co.uk



GARMENT TYPE	GENERAL RULE	AVERAGE QUANTITY
STRAIGHT TROUSERS	Twice the length plus 0.25m	2m
STRAIGHT SKIRT	Length plus 0.25 m	1.25m
GATHERED SKIRT	Twice the length plus 0.25m	2.5-3m
SLEEVELESS TOP	Length of top plus 0.25m	1.25m
SLEEVES	Length plus 10cm	0.75cm
SHIRT	Length of shirt plus length of sleeve plus 0.25 m	1.7m-2.5m
COAT	Twice length, plus sleeve length, plus 0.5m	2.5-4m
A-LINE DRESS	Twice the length plus 0.25m	1-2m
DRESS WITH GATHERED SKIRT	Twice length plus 1m	2.5-3.5m
DRESS WITH CIRCLE SKIRT		3-5m



Simplicity 1609

and I record this in my *Maker's Workbook* sewing planner.

As a short lady, I can get a sleeveless shift from 1m, a long sleeved version from 1.5m if the fabric is wide and I can get an A-line mini skirt from just 60cm of fabric!

Within the pattern drafting process, creating a layplan allows you to set the fabric quantities. Even if you're working on a pattern with an existing layplan you may decide to redesign the layout for pattern efficiency, or perhaps you've done this when working with napped or one-way patterned fabric and needed to take matters into your own hands! You should ideally do this before the fabric is bought and cut, but it's great for projects with lots of pieces when you want to be economical with expensive cloth! Essentially you mark out an area on your table (or floor) that's a standard fabric width and lay the paper pattern pieces in that area. Once you've got them all lined up with the grain or fold, measure the overall length and that's your yardage. I often use an actual piece of cloth I have lying around to work out length.

Tailors traditionally have a handy reference chart for standard 'yardages' for suits etc. You can create your own

“
Having a picture
of the back of my
favourite pattern
on my phone
means I can
quickly see what
sort of quantities
I'd need

using a mixture of TNT pattern envelope quantities, your own layplans and these basic rules of thumb.

These are just guidelines for standard garments however, and it's really important to remember that if you are buying fabric with a repeating, one-directional pattern you'll need more! Usually one repeat depth per length needed (good fabric suppliers should help with this bit of maths!). Working on the bias also means more

fabric! And remember that wide leg trousers and very flared skirts will eat up more of the width of your fabric so buy extra!

ABOUT CLAIRE-LOUISE

Claire-Louise is an author, pattern designer, teacher and costumer. We recommend Claire-Louise's new course
www.learnstosewwithapro.com/ultimate-beginners

Claire-Louise's book, *The Great British Sewing Bee: Fashion With Fabric*, accompanied the third series of the show and is priced £20 from www.quadrille.co.uk

SHOP OF THE
MONTH

DRAGONFLY FABRICS

www.dragonflyfabrics.co.uk

We chat to Simon, one half of the husband-and-wife team that runs online fabric shop Dragonfly Fabrics



Tell us a bit about how you came to set up the shop

My wife Dorte was working for designers in London and when the family moved down to Sussex she started running sewing classes in the village. At the time there were very few online fabric shops specialising in dressmaking fabric so we decided to set up Dragonfly Fabrics, using Dorte's contacts in Germany to source quality fabric. The range has expanded enormously over the years with fabric now coming from around the world. Alongside our famed boiled wool we also have a large selection of natural linen and cotton and a comprehensive range of bio linen.

Which is your favourite fabric you are selling at the moment?

The boiled wool collection continues to grow and it is always exciting when we get new colours. We have just received ochre, a beautiful shade for the autumn and early winter. Boiled wool is a natural product

that's perfect for autumn and winter clothing and also year-round layering; it is also very easy to cut and sew. Another fabric I think will be a real favourite this winter is the boucle cotton stretch; its Lycra content gives it stretch and makes it ideal for dresses and little Chanel-style bolero jackets.

Have you had any particularly memorable moments with customers?

We are an online shop and don't often get the opportunity to meet our customers face to face, so it is always nice for us to get to shows and meet our customers. We do hold open days at our lovely studio in Mayfield, and it's well worth the trip. In addition to seeing our lovely fabric you can enjoy tea and delicious cakes! You can also visit us by appointment, so if you are ever nearby do give us a ring and come and see us.

What sets you apart from other shops?

We like to think it is the unique quality of our dressmaking fabric that sets us apart. We also pride ourselves on our customer service and are always happy to help with any query, whether you have just taken up sewing or are an experienced seamstress. We hold a large collection of independent patterns – from beginners to advanced – as well as

a comprehensive range of haberdashery items, so we really are a one-stop shop for all your dressmaking requirements. We are on social media and produce a weekly newsletter with exclusive offers and sewing tips.

Is there anything new or exciting coming up that you'd like to tell our readers about?

We are very excited about our new website which is soon to launch. It is just in time for our autumn collections that are following our very popular summer sale. The autumn really is a very exciting time for us with all the new fabric and patterns on offer. To see the full range Dragonfly Fabrics has to offer, visit www.dragonflyfabrics.co.uk

Visit us!

Find Dragonfly Fabrics on Facebook
Instagram [Dragonflyfabrics](https://www.instagram.com/dfflyfabrics)
and Twitter [@dfflyfabrics](https://twitter.com/dfflyfabrics)



LINTON DIRECT >>>

The world's most innovative fabrics

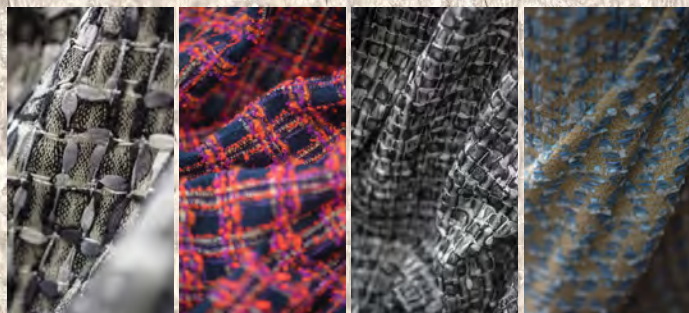

Linton Tweeds design and weave luxury fabrics for the world's most exclusive fashion houses



See our website for the Linton Direct collection

Use discount code
lovesewing10

www.lintondirect.co.uk



• m is for make •

*A handpicked collection of fabrics...
delivered to your door*

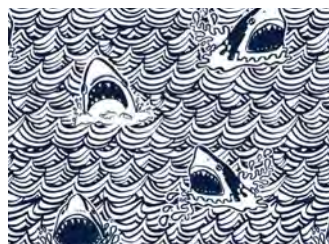
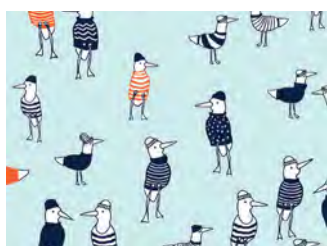

www.misformake.co.uk



MINERVACRAFTS

The UK's largest Fabric, Sewing Pattern and Haberdashery Online Retailer!

Winner of Best Online Retailer in the British Sew Awards

Follow the Minerva Crafts Blogger Network for Daily Sewing Inspiration #MCBN

Special Offer for Love Sewing Readers!
10% Off Lucky Dip Fabric Bundles. Limited time only. 1 use per customer. Cannot be used in conjunction with any other offer. Exclusions may apply.
Coupon: LUCKYDIPLS10



Handmade GIFTS

Make presents that are stitched with love for your nearest and dearest!

For Dad



CHRISTMAS WRAPPING

Sew your dad a gift that he can wear straight away! Newcastle cardigan, Thread Theory Patterns, sizes XS-XL, see www.hantex.co.uk/mystockist

DINNER'S READY

We've found an easy tutorial for a smart canvas apron he'll love. www.weallsew.com/apron-tutorial



TIED IN A BOW

A novelty-print bow tie is great for dads with a sense of humour! Try a sewing kit, £18 from shop.thenewcrafthouse.com

TO HAVE AND TO HOLD

Whip up a fancy new bag using the Poolside Tote by Noodlehead Patterns and an eye-catching fabric like Midnight Blue Underwater Reef from Cloud9 Fabrics! For info on both items, see www.hantex.co.uk/mystockist



For Mum



SO DREAMY

Show Mum you care with a custom-made sleepwear set! Carolyn pyjamas from Closet Case Patterns, sizes 0-20, see www.hantex.co.uk/mystockist

WATCH THE CLOCK

This fun felt kit includes everything you'll need to make a beautiful gift, with real clock mechanism! Pick up your kit for £9.95 from www.themakery.co.uk



For your Bestie



SNUG AS A BUG

If you want to score major brownie points, make your best friend the snuggly Blackwood Cardigan by Helen's Closet. Sizes XS-XXL, PDF pattern \$14 (approximately £10) from www.helenscloset.ca



FITS TO A TEE

A loose-fit jersey top makes a great gift for your fave girlfriend! Grab the PDF pattern to start right away. \$14 (approximately £10), sizes 0-20 from store.closetcasepatterns.com



ALL TANGLED UP

These clever knot cushions are made from tubes of jersey fabric tied into shape! Find the tutorial at www.littleinspiration.com

For Teens



ZIP IT UP!

For boys that are hard to please, keep it simple with the McCall's 6614 hoodie pattern. Sizes XM S-L and XN XL-XXXL, £9.25 from www.sewdirect.com



RUN AND PLAY

What could be more fun than a chambray dungaree set? Try the BurdaStyle Overalls 07/2016 #109, PDF pattern \$5.99 (approximately £4.50) from www.burdastyle.com

IT'S GOOD TO BE GREEN

Why not make some easy fabric planters in pop colours like Take Shape from Art Gallery Fabrics? See www.hantex.co.uk/mystockist



Secret Santa



THEY'LL BE MADE UP

Mix fabric scraps with the Threader's faux leather range to create these cool cosmetic pouches. £6.99 per metre from www.crafterscompanion.co.uk



FEATHERED FRIEND

Soft toy patterns can make great novelty cushions or doorstops. This owl is made from Trekant Rows Candid from the Heartland collection by Art Gallery Fabrics. £2.60 per FQ from www.habbydays.co.uk



ROAR OF APPROVAL

These DIY appliqué T-shirts are irresistible! Kwik Sew 0133, sizes T1-T4 £8.99 www.sewdirect.com



BUNDLE OF JOY

Indulge in some tiny sewing with this bumper pattern pack. £18.99 from www.minervacrafts.com

SWEET AND SIMPLE

Simplicity 1207 is a fun and quick make for toddlers. Just £7.50 from www.simplicitynewlook.com



Mini Makes



Maud's Fabric Finds

Specialist in French textile and hand printed fabrics

Now stocking a large range of chambray, cotton lawn and knits



15% OFF!

AT CHECKOUT ENTER
sewing15



www.mauds-fabric-finds.com



10% OFF
with the code
LOVESEWING44
in-store and online



Scotland's best selection of dressmaking fabric, haberdashery, interiors fabric since 1946
Shop in-store or online
Glasgow - Edinburgh - Hamilton - Falkirk

www.remnantkings.co.uk



New fabrics added every week

£2.50 UK P&P sewoverit.co.uk/shop
FREE for orders £75+ 0207 326 0376

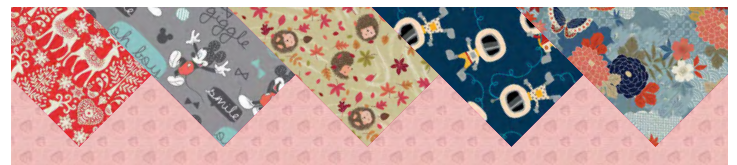

Rooftop Fabrics are proud to offer an every expanding range of fabrics, including: Plush, Cottons, and other specialist items.

Tel: 01420 260036 Email: website@rooftopfabrics.com

www.rooftopfabrics.com



An Aladdin's cave full of fabrics including Cotton Poplins, Linens, Wool Tweeds & Polyesters
100% Cottons for Patchwork and Quilting
Knitting yarn and haberdashery
Courses and workshops
Agents for Brother Sewing Machines

Visit our shop or buy safely online
31 Main Street, Bentham, North Yorkshire, LA2 7HQ
Tel: 015242 61868

www.temptationsbentham.co.uk

For shop opening times please see our website

SEWING

workshops

Book yourself in to one of this month's top workshops and expand your sewing horizons

GOLDSTITCH

Tanhills, Nettleworth

Goldstitch is a unique fabric shop with a sewing and embroidery studio situated on the outskirts of Durham. It stocks Liberty fabric, a fabulous range of quality dressmaking materials and craft cotton as well as haberdashery. It can personalise good-quality cotton and linen handkerchiefs and these make excellent gifts for Christmas or special occasions such as birthdays or weddings.

www.goldstitch.co.uk
0191 3711 444

16TH OCTOBER

Jersey dress day

Make an easy-to-wear stretch dress with raglan sleeves. Learn how to sew with stretch jersey, choose the correct fabric and read the pattern to determine your size. Four spaces available.

Cost: £45

23RD OCTOBER

Appliqué cushion cover

Learn the process of appliqué while sewing a 16" envelope cover. Skills include applying appliqué, stitching the stag in place and adding detail. Included is the stag appliqué, ribbon and bell. 50cm of main fabric is required and there's 20% off shop fabric on the day. Five spaces available.

Cost: £25

26TH OCTOBER

All about the skirt

Progress from commercial patterns to a made-to-measure perfect-fit garment. Sew your toile for fitting and learn how to adapt your custom-made straight skirt pattern to five different styles. Pattern paper and calico fabric is provided, instructions for completing each skirt draft are yours to take home. Maximum capacity of two students.

Cost: £115



2ND NOVEMBER

Liberty pyjama workshop

Sew a set of Liberty cotton lawn pyjamas and matching bag. This is a free tuition workshop when you purchase 2m of Liberty fabric in store (payable when you book), which will make your pyjamas. Elastic, ribbon and stretch lace will be provided. Light refreshments of tea coffee and cake available. Five spaces available.

Cost: £42

HAPPY HARE

Chapelton, Sheffield

Happy Hare is an independent sewing store based in Chapelton, Sheffield. It stocks a wide range of fabric including Michael Miller, Riley Blake and Tula Pink. Materials will be provided for all workshops. For sewing workshops you must be able to use a sewing machine with a reasonable level of skill. On that basis, you should have either completed an 'Introduction to sewing machines' session or have used a sewing machine to undertake simple tasks like joining two pieces of fabric.

handmadehappyhare@yahoo.co.uk
www.handmadehappyhare.com
0114 245 5996

14TH OCTOBER

Simple tunic

Suitable for novice dressmakers, this class teaches you to make a tunic you can wear as a poolside cover-up or with boots and jeans for a relaxed autumn outfit.

Cost: £40

21ST OCTOBER

Jelly roll tote bag

Make a colourful reversible tote bag using pre-cut fabric strips with our easy and fun tutorial.

Cost: £30

22ND OCTOBER

Needle-felted squirrel/hare

Come along and try needle felting. Suitable for an adventurous beginner.

Cost: £35

4TH NOVEMBER

Introduction to sewing machines

In this class you will learn the basic skills involved when using a sewing machine. You can then sign up for any of Happy Hare's other sewing classes.

Cost: £20





NIMBLE THIMBLES

Swindon, Wiltshire

This wonderful shop provides you with everything you need for sewing, quilting, knitting and crochet including fabric, patterns, sewing machines, yarn and haberdashery, plus a superb sewing school.

www.nimblethimbles.co.uk

01793 950750

14TH OCTOBER

Chicken cushion

During this enjoyable and relaxed afternoon workshop you will make a very cute chicken cushion with appliquéd feathers. Some sewing experience is needed for this workshop.

Cost: £48

28TH OCTOBER

Handbag

Make a beautiful lined handbag with an adjustable strap, internal pocket and magnetic clasp fastening. Once you've mastered this bag you'll be sure to have lots of requests from friends to make more!

Cost: £55

4TH NOVEMBER

Jersey top/dress

During this class you will learn how to make a versatile stretch jersey top with a choice of sleeves and length. You will learn how to read the pattern, cut it out, transfer pattern markings, sew seams



and finishes, hems, put in sleeves and use an overlocker.

Cost: £55

18TH NOVEMBER

Winter poncho

During this one-day workshop you will make a stunning winter poncho. You will learn how to read the pattern, cut it out, transfer pattern markings, sew seams and finishes, hems and necklines and take home a pattern worth £8.75!

Cost: £55

4TH NOVEMBER

The curtain hour week one: herringbones and ladders

This rolling programme of classes can be booked individually. Starting with hand sewing stitches, each week teaches you a new skill needed to make beautiful curtains for your home. Materials included.

Cost: £20

11TH NOVEMBER

Upcycling party dress special

Bring along a garment that you would like to restyle or add a bit of sparkle to. It could be something that doesn't fit or an old favourite that would benefit from an update. An afternoon of fun and probably cake!

Cost: £35

15TH NOVEMBER

Taster class (daytime and evening)

These classes are an opportunity to have a go at machine sewing, meet the teacher and discuss what we do in weekly classes. You will work on a small sewing project. Materials included, maximum of five students.

Cost: £20

25TH NOVEMBER

Mother and child – make a Christmas stocking

These classes are an introduction to machine sewing for younger children (from eight years old). Mother and child share a sewing machine and mum gets to help with the tricky bits! Materials included

Cost: £35



SWEET SEAMS

East Molesey, Surrey

Sweet Seams is the perfect venue for all your sewing needs. It offers a wide range of classes suitable for sewists from eight years old, plus fabric, haberdashery and handmade gifts.

www.sweetseams.co.uk

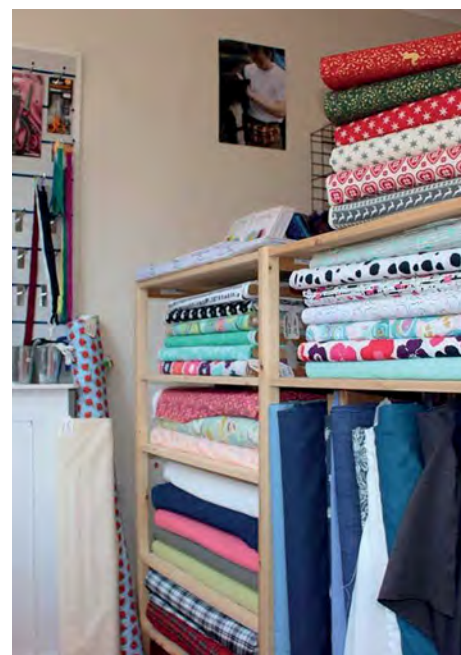



Leon's Fabric Superstore
 419 Barlow Moor Road
 Chorlton
 Manchester
 M21 8ER
 Tel: 0161 881 7960

Barry's Fabric Superstore
 1 Moseley Street
 Digbeth
 Birmingham
 B5 6JX
 Tel: 0121 622 6102

We're also at **Green's Fabrics**
 Cicly Lane
 Blackburn
 BB1 1HQ
 Tel: 01254 680 954

1000s of Rolls at Realistic Prices!

Stockists of all kinds of

- Fashion Fabrics
- Woollens
- Worsteds
- Polywools
- Polyesters
- Cotton
- Dance Wear
- Linings
- Bridal Wear
- Satins
- Suiting
- Lycras



and much, much more!

VOGUE
PATTERNS

NEW
LOOK

JOHN KALDOR
LONDON

burda

www.leonsfabrics.co.uk



Phil Collins Fine Furniture

~ Bespoke Cabinet Maker ~

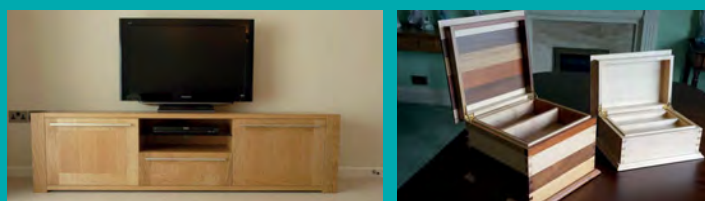

I make each piece of furniture by hand
 to your own size and specification

- Sewing Cabinets,
- Sewing Tables &
Cutting Out Tables
- Sewing Boxes &
Jewellery Boxes
- Bookcases
- Sideboards
- Media Units
- Fitted Bedrooms
and Kitchens

All of our pieces can be made
 in Solid Wood or Wood Veneer

Please visit our website to see all of our furniture

www.exclusivefurniture.co.uk
 07714958622

Cotton Reel Studio



www.cottonreelstudio.co.uk

CLOTHSPOT

OUR FABRICS | YOUR FASHION



clothspot.co.uk
 01775 640996



New fabrics
 every Friday!





The full **PONTE**

These paperboy trousers are perfect for autumn. Giving the illusion of a tailored trouser, the back elastic makes them super comfy to wear

Project **CHRISTINA ALBECK** Wardrobe By Me

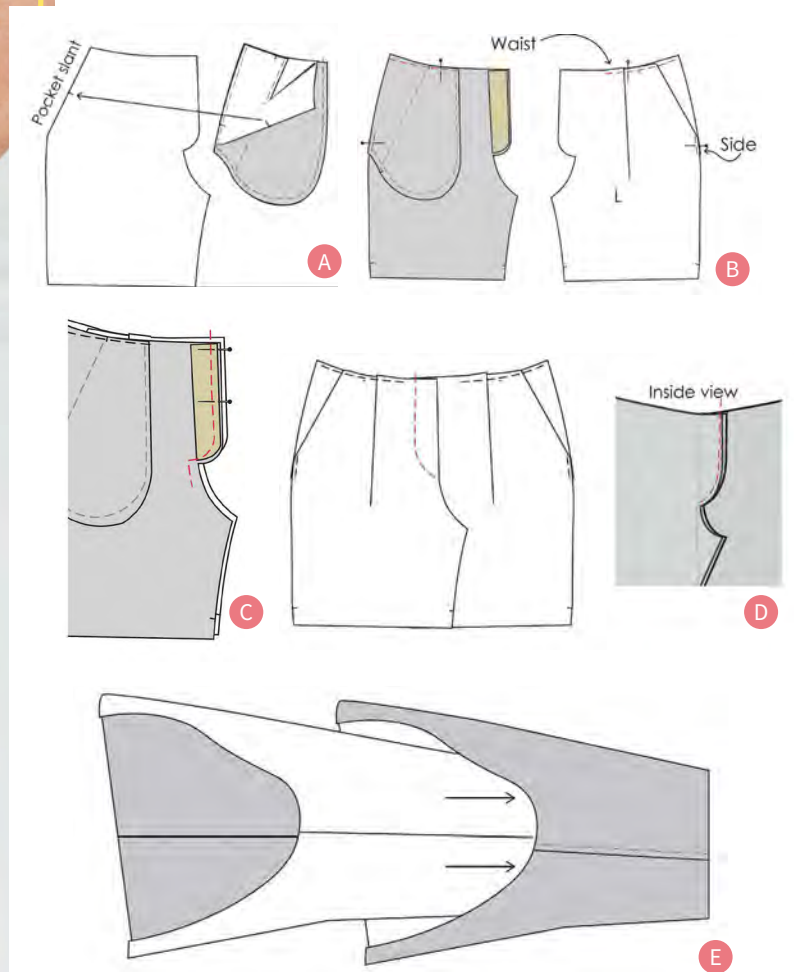

SIZING:

	Waist	Hip	Finished waist	Finished hip	Inseam
0	23"	32"	23"	37½"	27½"
2	24½"	33½"	24½"	39"	27½"
4	26"	35"	26"	40½"	27½"
6	27½"	36½"	27½"	42"	27½"
8	29"	38"	29"	43½"	27½"
10	30½"	39½"	30½"	45"	27½"
12	32"	41"	32"	46½"	27½"
14	33½"	42½"	33½"	48"	27½"
16	35"	44"	35"	49½"	27½"

CUTTING:

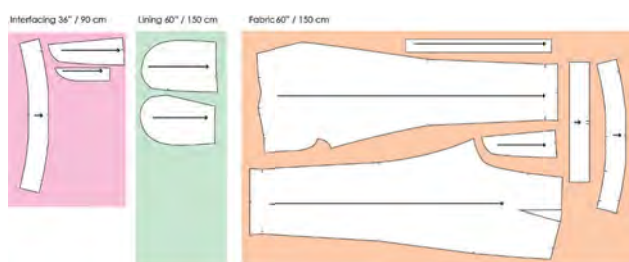

MATERIALS & TOOLS:

- 1.5m 60"-wide ponte roma fabric
- 0.6m cotton for pocket lining
- 0.5m fusible interfacing
- 0.3m 4cm-wide elastic
- templates downloaded from www.love sewingmag.co.uk

NOTES:

1cm seam allowance is included in the pattern with hem allowance of 4cm

HOW TO MAKE:

- 1 Fuse interfacing to the WS of the front waistband, the pocket facing, the front fly and the WS of the pocket opening.
- 2 Neaten the raw edges as you work as this is not referred to again in the instructions.
- 3 Place the WS of the pocket facing on top of the RS of big pocket bag. Sew in place.
- 4 Sew the small pocket bag and big pocket bag together along the curved edge, RST.

- 5 Press, pin and baste the front pleat in place, folding the excess towards the centre front.
- 6 Sew the small pocket bag to the front at the pocket opening RST. (See Pic A.)
- 7 Press the seam and understitch the seam allowance to the pocket lining.
- 8 Baste the pockets to the front at the waist and at the side. (See Pic B.)
- 9 Sew the fake fly together as illustrated. Fold the fly towards the right press the seam. Sew the fly to the right front as illustrated. (See pics C and D.)
- 10 Assemble the back darts and press the excess towards the centre back.
- 11 On each leg, sew the back to the front at the side seam with RST. Sew from waist to hem, matching the notches at the knee.
- 12 With RST sew the inseam along the curved edge, RST.



- 19 Turn the waistband RS out and baste the bottom edge of the back waistband together, creating a tunnel.
- 20 Insert the elastic into the tunnel, and secure the elastic in the tunnel at each of the waistband seams.
- 21 Sew the waistband to the trousers RST. Press the seam down carefully.
- 22 Turn up the bottom seam allowance of each belt loop and top-stitch to the waistband.

- 23 Try on the trousers before deciding on the length you want them to be. The cuff is optional.
- 24 Fold and sew the allowance to the inside and hem the trousers.
- 25 Twist half of the allowance to the outside (only 2cm is visible from the inside). Press the cuff in place and tack at each side seam. (See pics H and I.) You are done with your paperboy trousers!

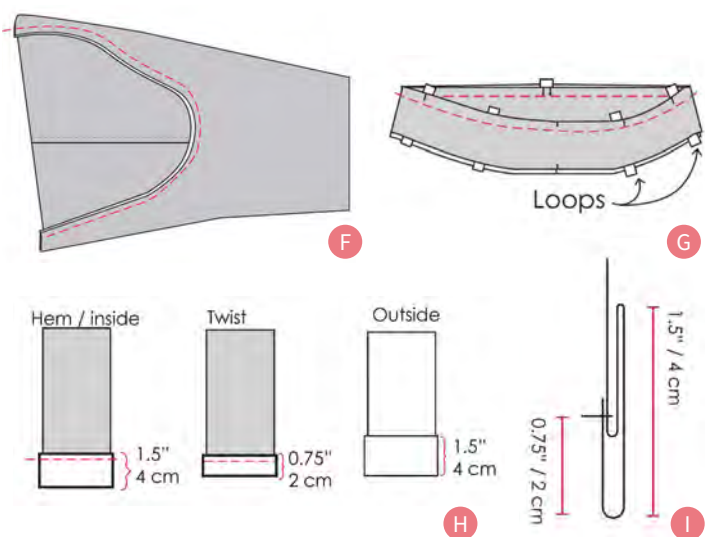

to crotch, matching the leg at the knee notches.

13 Turn one leg RS out and the other WS out. Place one leg inside the other RST and align the crotch seam. Sew together from the bottom of fly to back waistline. (See pics E and F.)

14 Fold and sew the belt loop together along the long side RST. Turn it inside out, press and cut it into five belt loops.

15 With RST sew the short ends of one set of front and back waistbands, creating a circle. Repeat for the other set of waistbands, which will become the waistband facing.

16 Place the belt loops onto the waistband at the belt loop notches and with RST sew the upper edge of the two waistband circles together, trapping the belt loops in the seam. (See Pic G.)

17 Turn the seam allowance of the outside waistband towards the back, and the opposite for the inside waistband.

18 Press and understitch the seam allowance to the inside waistband circle.

Say hello!

Turn to page 10 to read our exclusive interview with Christina of Wardrobe By Me patterns!

Show some **LOVE**

MATERIALS & TOOLS

- 21.5cm square white linen fabric for front panel
- 30x107cm red dot fabric for borders and backing
- dark red embroidery floss
- 32cm square cotton/polyester mix wadding
- 130cm red jumbo rickrack
- 30cm-square cushion insert
- spray adhesive
- templates downloaded from www.lovesewingmag.co.uk

CUTTING:

From the red dot fabric, cut:

- 2 6.5x21.5cm strips for top and bottom borders
- 2 6.5x32cm strips for side borders
- 2 21.5x32cm pieces for backing panels

NOTES:

The embroidery motif uses backstitch, French knot and cross stitch

A 6mm seam allowance is used throughout unless otherwise stated
Finished size: 30cm square

HOW TO MAKE:

- 1 Transfer the heart cushion motif template onto the 21.5cm linen square using your preferred method.
- 2 Pin, then sew the top and bottom red dot border strips to the linen square, using a 6mm seam. Then pin and sew the two longer red dot strips to each side to complete the preparation of the front panel. Press well.
- 3 Take the piece of wadding and lightly apply spray adhesive, while closely following the manufacturer's instructions. Smooth the prepared front panel on top of the wadding and secure in place by stitching 6mm all the way around the outside of the linen square.

Influenced by folk art and embroidery, the classic redwork style can be used to create this heartwarming motif and cushion

Project **MANDY SHAW**



MASTERCLASS STITCH GALLERY

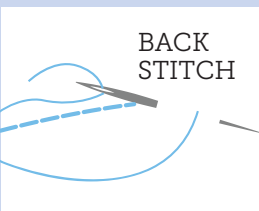
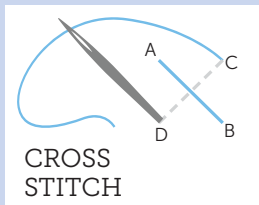
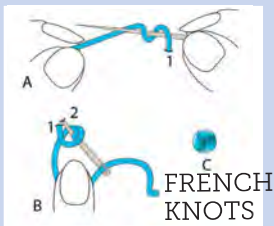

- Embroider the heart design using backstitch, working French knots in the centre of the hearts and for birds' eyes, and a single cross stitch in the oval beneath the centre top heart. Sew a long running stitch border 6mm in from the edge of the linen square.
- Check your cushion top measures 32cm square and trim if necessary. Take the rickrack and, starting halfway down one side of the right side of the cushion top, pin on the braid all the way around, aligning the edge of the rickrack with the raw edge of the fabric and gently curving the braid around the corners.

ABOUT THE BOOK



Simply Redwork, by Mandy Shaw,
£22.99 from
www.sewandsocooking.com

- Baste the rickrack in place 6mm from the edge, sewing down the middle of the braid, so that when the cushion is turned right side out, only little half moons will show.
- To make the envelope back, take the remaining two red dot fabric rectangles and turn under 6mm along one long edge of each, turn under again and stitch the hem in place. Overlap the hemmed edges

Top tip

Fold back the ends of your rickrack so the raw edges are trapped in the seam allowance to prevent fraying

- (RS facing up), so that the two rectangles measure 32cm square and pin in place.
- Pin the envelope back to the cushion front, right sides together, and sew around the outside edge, sewing on the same line as the rickrack. Snip the corners and trim the seams.
- Zigzag-stitch over the seams to prevent fraying and turn the cushion cover right way out. Place the cushion insert inside and take a seat, you're finished!

Simple
Sew

Get set for

AUTUMN

with stunning patterns



For patterns, inspiration, video tutorials and more head to
www.simplesewpatterns.com
& selected retailers



simplesewpatterns



simplesewpatterns



simplesewpatterns



simplesewUK

CUT
OUT &
KEEP

Your free

Butterick

GIFT

Dapper DOG



Make your favourite pooch a snuggly coat for stylish and walkies! Simply cut out the instructions and keep them with your free templates

Shopping list

Royal Stewart tartan, £7.99 per metre

www.remnantkings.co.uk

Cream sherpa fabric, £10.99 per metre

www.minervacrafts.com



CUTTING:

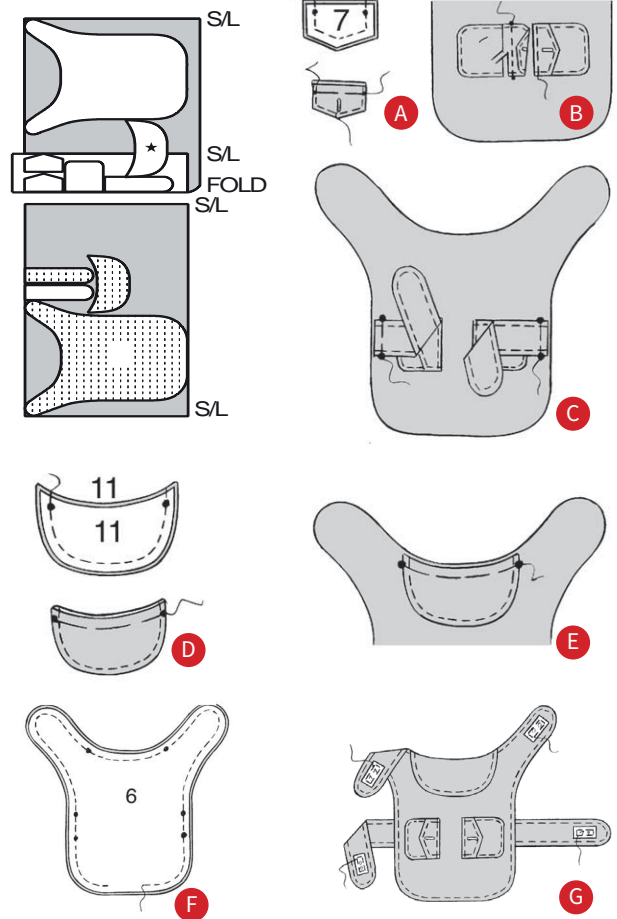

MATERIALS & TOOLS:

- 50-70cm 115-wide main fabric (brocade, wool & wool blends, tweed, herringbone)
- 50-70cm 150cm-wide contrast fabric (sherpa, fleece, wool boucle)
- 25cm Velcro
- 2 2cm buttons
- templates provided

SIZING:

Length from base of neck to base of tail: XS (28cm), S (41cm), M (53.5cm) and L (66cm)

NOTES:

Use a 1.5cm seam allowance

HOW TO MAKE:

- 1 Cut out your pattern pieces following the layplan and transfer pattern markings to the WS of the fabric.
- 2 Finish the upper edge of each pocket by turning under 6mm and stitching in place. Stitch curved edges of pocket 1cm from the raw edge using

- long machine stitches. Turn the upper edge of pocket to inside along fold line; press. Top-stitch in place.
- 3 Turn in the seam allowance on the sides and lower edges of the pockets, pulling thread to ease in fullness on the curve. Press.
- 4 Pin pockets to the back, matching large circles. Stitch close to sides and lower edge.
- 5 For each flap, stitch two flap sections together, leaving upper edge open. Turn RS out and press. Baste raw edges together.
- 6 Edge-stitch the flap (stitching 3mm from the edge). Make a buttonhole on the flaps at mark. (See Pic A.)
- 7 Pin flap sections to the back, matching small circles. Stitch along the seam line. Trim the seam allowance to scant 6mm, being careful not to cut back of dog coat. Turn the flap down over the seam and press. Edge-stitch the upper edge. (See Pic B.)
- 8 Pin one belt section to

- one contrast belt section, keeping edges even. Stitch, leaving end with large circles open. Turn RS out and press. Baste the raw edges together. Top-stitch the belt as shown, stitching 6mm from the edge.
- 9 Pin belt sections to the back, matching large circles with contrast side up and baste. (See Pic C.)

- 10 Stitch collar sections together, leaving upper edge open. Turn RS out; press and baste opening. Top-stitch the collar. (See Pic D.) Pin to back, matching large circles with contrast side up. Baste in place. (See Pic E.)
- 11 Place the backs RST, keeping the back and collar inside. Sew, leaving an opening in the bottom edge. (See Pic F.) Turn RS out and press. Slip-stitch the opening closed. Top-stitch 6mm from the edges of the back, keeping the collar free of stitching.
- 12 Cut a 5cm-long section of Velcro. Position for neckline closure as shown. (See Pic G.)
- 13 Cut one 10cm-long section of Velcro. Position on the belt for waist closure as shown. (See Pic G.)
- 14 Stitch the Velcro in place with co-ordinating thread. For a lead opening, make a buttonhole at the mark on the centre back. Sew button to the pockets at markings.

ABOUT



This cute dog coat is one of three styles taken from B4885. To see more of Butterick's crafty pattern range, visit www.sewdirect.com

BOOK OF THE MONTH



Fat Quarter Christmas

by Jemima Schlee, £12.99 GMC

Tell us what inspired the book

Making things from small pieces of fabric is something I do almost all the time. I write craft books and contribute to magazines, showing readers how to make things, writing up instructions and taking step-by-step photographs as I go. I love finding uses for small and precious pieces of fabric I've secreted away and kept in drawers and boxes, grouped in colours.



© Alex Bamford

IN THE GOOD BOOKS

Our pick of this month's new sewing and dressmaking books

What's your favourite project inside?

One of my favourite projects in the book are the fairy lampshades – you'd be surprised how quick and simple it is to make use of the smallest of fabric scraps. Another favourite is the kindling bag – this makes a really great Christmas gift!

How early do you start making your Christmas presents and decorations? Don't tell us we're too late!

It may sound a bit mad, but I usually make my Christmas cards during the autumn half term – around the last week of October. I make tree decorations that I send out to friends and family as a Christmas card. I set myself up years ago actually, because kind friends now expect one every year and I feel I can't let them down! As for presents, I have to admit that I do have a 'present cupboard' I fill throughout the year. Any fresh makes and presents I usually settle down to in December – it's a great way to get into the mood for Christmas.

What are your favourite quick-make Christmas gifts to sew?

I think that the best gift for anyone is

Jemima



a bag; a tote bag, drawstring bag, little sponge and make-up bags, clutch bags, camera bags and purses. Some are quite complicated, but tote bags and drawstring bags are fairly simple. Choosing the fabric and colour means that you can tailor the projects to a specific person too.

What can we expect from you over the next year?

I'm working on three book ideas at the moment, but they are still at an early stage and mostly 'in my head'. And I'm travelling to New York for a month of planning and research – what a lucky person!

STITCHER'S DELIGHT

Brush up on your stitches with *Embroidery, A Maker's Guide*. Inspired by V&A collections and techniques from around the world, it's available from www.thamesandhudson.com at £16.95.

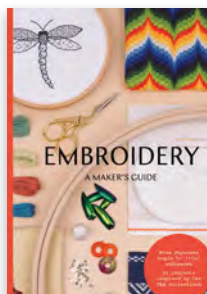

COLOUR US HAPPY

Becky Goldsmith guides you through every step of making a standout psychedelic quilt with her latest book, *The Magical Unicorn Quilt*. Pick up your copy for £16.99 from www.searchpress.com



SEW IT VINTAGE

Tea dresses, tailored trousers and everything in between. If you've got a passion for vintage fashion, check out *Making Vintage 1940s Clothes for Women* by Sarah Magill. £25 from www.crowood.com



FABRIC FOCUS



Show no JERSEY

SAVE 20% on jersey fabric at Higgs & Higgs. Head to www.higgsandhiggs.com to see its gorgeous selection of jersey and use the code **LOVE45** at checkout to save

Fabric shopping

- 1 Arrows cotton jersey, £13.99 per metre 2 Turquoise stripe jersey with elastane, £12.99 per metre 3 Mustard Pinwheels jersey, £12.99 per metre 4 Navy stripe Breton yarn-dyed jersey, £12.99 per metre 5 Mint Panda jersey, £13.99 per metre 6 Yellow Clouds jersey, £13.99 per metre 7 Pink Magical Unicorns jersey, £13.99 per metre 8 Grey OXOX marl jersey, £12.99 per metre 9 Mint Plus cotton jersey, £12.99 per metre 10 Black Criss Cross cotton sweatshirt jersey, £12.99 per metre
All available from www.higgsandhiggs.com

Ponte Roma - Boiled Wool - Lambswool - Chambray
New Patterns - Art Gallery Knits - Double Cloth



10 % off
Code
"Sew53"
Expires 1/12/2017

New Winter Wool Fabrics

www.dragonflyfabrics.co.uk Tel 01892-731087

Fabric
Patterns
Workshops

www.leicestershirecraftcentre.co.uk



Tel: Swindon
01793 950750

Nimble Thimbles

Fabrics
Yarn
Haberdashery
Workshops
Janome Sewing
Machines
Elna Sewing Machines



www.sewcreative.org.uk

Sew Creative for your Christmas makes & gifts: fabulous fabrics, haberdashery, Janome sewing machines, vouchers, workshops & sew much more!

T: 01730 858 020 E: info@sewcreative.org.uk

20-22 Lavant Street, Petersfield,
Hampshire, GU32 3EW

Jaycotts EST. 1920

YOUR FIRST CALL FOR
**SEWING
SUPPLIES**

**FREE MAIL
ORDER CATALOGUE
CALL: 01244 394 099
GO ONLINE
JAYCOTTS.CO.UK
OR VISIT OUR
CHESTER STORE**

JAYCOTTS LTD, UNIT D2,
CHESTER TRADE PARK, BUMPERS LANE,
CHESTER CH1 4LT 01244 394 099



With Wendy Ward

What can QUILTING teach us?

You might be forgiven for thinking that there would be nothing for a dressmaker at a quilt festival, but think again!

I visited The Festival of Quilts at Birmingham's NEC this August. This is a well-established event in the textile show calendar that describes itself as Europe's leading patchwork and quilt show.

For a long time I have admired the skill and design that goes into patchwork and quilting and some of the finished results really appeal to me. I find the social history of how quilting has evolved from a necessity into an art form fascinating and have been inspired by the way it's often used to give a voice to divisive political and social issues. In my own patchwork journey I have dabbled as far as a small wonky quilt that I display as a wall hanging. It uses various fragments of clothing and textiles from mine and my partner's family, and I do love to incorporate the odd bit of patchwork inspiration (both spirit and style) into my dressmaking projects.

COMPETITIONS

If you've ever been to a big sewing show such as the Knitting & Stitching show, Handmade Fair or the Stitching, Sewing & Hobbycrafts show, the format will be familiar. There are shopping opportunities, workshops, demonstrations and galleries but something completely unfamiliar to dressmakers and particular to quilting shows are the competitions. At The Festival of Quilts there were 14 distinct competition categories from Contemporary Quilts to Quilt Creations, plus a Best In Show award.



One of my favourite pieces in the Quilt Creations category by Milena Zdravkova

The kudos of winning one of the awards is the primary prize but there is also a total of over £25,000 in prize money available across the categories! The judges that score all the entries also leave cards on some of their favourite pieces that didn't win, highlighting them as 'Judges Choice' or 'Specially Commended'. It's obvious that the competitions are taken very seriously and are an important part of the show.

GALLERIES

The competitions are inspiring and a joy to view and are open to anyone to enter, but there are also several curated galleries and exhibitions throughout the event. I found a lot of these galleries really inspiring and they were packed full of a high level of craftsmanship, artistry and design skill. I really get the sense that there is an appreciation and celebration of experience and expertise over celebrity within the quilt world, something that definitely isn't as evident in the dressmaking world.

There were some solo artist galleries, and I particularly loved Dianna Harrison's Traces In Cloth show in which she explored the beauty of marks left behind on fabric from processes such as stitching and folding that are unpicked and unfolded after being bleached, over dyed or over printed.

Work from quilt groups and curated galleries were also full of inspiration. My favourites were Best of Quiltcon (a big US show showcasing modern quilting), Art Quilt Fusion (a European group of international textile artists) and Fine Art Quilt Masters (an internationally juried competition

ABOUT WENDY WARD

I spent seven years working in the fashion industry before moving to teach dressmaking from my own studio, MIY Workshop, in Brighton. MIY Collection is my range of easy-to-follow modern sewing patterns. I have also written two books about dressmaking both available from all good bookshops. My third book will be out in February 2018!
www.wendyward.co.uk
www.miycollection.com
www.miyworkshop.co.uk

vintage fabric stands. Any book you could ever want on patchwork and textile art could be found at the show and there were a few big textile art surface decoration stands such as the popular Art Van Gogh, which also appealed to dressmakers who like to dabble in a bit of dyeing and printing.

TALKS, WORKSHOPS AND DEMOS

I didn't get the opportunity to attend any workshops as I was only there for one day but there was plenty on offer for dressmakers – a wide range of surface design techniques to more traditional techniques such as appliqué and lots of talks on design and the design process. Plenty of food for thought!

NEXT YEAR?

I'll definitely go back! Maybe even for two days so that I could attend some talks and take a few classes. The Festival of Quilts is Europe's leading patchwork and quilting event, attracting 24,000 quilters from all over the world. The show is a celebration of quilting in all its forms, with over 300 exhibitors offering essential supplies, professionally curated galleries of quilts from leading international makers, 350 workshops, talks and demos plus a magnificent display of over 700 competition quilts. It is the ultimate patchwork and quilting experience. Find out more about this year's show and keep updated in time for the 2018 show at www.thefestivalofquilts.co.uk



Bling by Katherine Jones

celebrating the work of some of the world's leading quilt artists).

SOCIAL HISTORY AND POLITICAL VOICES

For me there were two standout areas of the show covering social history and the power of quilts. The first was the Walks of Life stand which had historical examples of many traditional forms of quilts and, most exciting, a couple of teaching samples of unfinished quilts that we were able to examine and touch! One was an English paper-pieced quilt top, still with all its original backing papers that included lots of fragments of letters dating from the 1800s, the other was a hand-embroidered Victorian crazy patchwork design and it honestly felt like a real privilege to be allowed to handle these pieces.



A beautiful piece by Adelheid Gubser showing feathers trapped between layers of fabric with hand-embroidered writing



The winning quilt in the Fine Art Quilt Masters competition, Birchington Breakwaters by Margaret Ramsay

The Women's Quilt is a project to highlight the issue of domestic violence against women and was completed for International Women's Day this March and presented at parliament. The quilt is made of 598 blocks, one for each of the women killed by their partners or ex-partners between 2009 and 2015 – a truly shocking statistic. You can follow this project on Instagram [thewomensquilt](https://www.instagram.com/thewomensquilt) and on its Facebook page of the same name.

SHOPPING

The lovely Jules of shop and pattern brand Sew Me Something was running one of only a handful of dressmaking-specific stands. There were lots of fabric retailers, many who also sell fabulous dressmaking fabric, including Rosenberg, Fabrics Galore and some lovely

PATTERN PICKS

Curated CLOSET

Sew a co-ordinating wardrobe with our special 50% discount on these selected styles from McCall Pattern Company



Kwik Sew 4070

Was £8.99

Do your wardrobe a favour and make a pair of tailored trousers. You'll wear these with everything from Breton tees to classic blouses. Available in sizes XS-XL.

SAVE 50%
with code **LOVESEWING45**

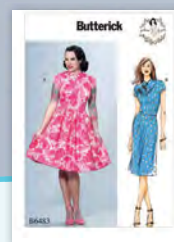

Butterick 6483

Was £8.95

In need of a party frock with a twist? Try Gertie's take on a cheongsam with mandarin collar and frog fasteners. Available in sizes AA 6-14 and E5 14-22.

Vogue 1556

Was £15

As the weather cools down, it's great to have a dress that layers. This modern take on the pinafore from Rachel Comey features a deep V neckline, co-ordinating belt and stunning pleated skirt! Available in sizes A5 6-14 and E5 14-22.



Kwik Sew 4190

Was £8.99

Forget *Flashdance*, imagine a soft and warm wool jersey version of this batwing top. For extra cosiness make the loose rollneck view. Available in sizes XS-XL



Vogue 8950

Was £13

Comfort and style are compatible with this clever colour-blocked top. Why not mix different prints for a bold look? Available in sizes A5 6-14 and E5 14-22.



Butterick 5466

Was £8.95

The unsung hero of any wardrobe, a simple but chic skirt. Make multiple versions in wool tweed, denim and crepe to get the most out of this staple pattern. Available in sizes BB 8-14 and F5 16-24.



Butterick

6388

Was £8.95

Whether you're lounging around or running errands this chic jersey dress will take you there. Available in sizes Y XSM-Med and ZZ L-XXL.



Kwik Sew

4188

Was £8.99

This faux wrap top has a dramatic look without the fear of the wrap coming undone! Available in sizes XS-XL



Vogue 9267

Was £14

We love the variations in this pattern pack that create a dress you can wear to work and play. Play with decorative topstitching, colour blocking and optional piping and one pattern can make several different looks. Available in sizes A5 6-14 and E5 14-22.



Butterick 6476

Was £5.25

Come rain or shine you'll step out in style with this wrap jacket. Choose between two styles of collar and self fabric ties. Available in sizes A 6-22.

*Claim your 50% discount on these selected patterns by calling 0344 880 1263 and quoting the code LOVESEWING45 before 2nd November 2017. Not available online. P&P charges still apply

Magical Sewing and Embroidery Offers

M280D

Sewing and embroidery machine

Enjoy the magic of Disney with the New M280D sewing and embroidery machine. Packed with advanced features it sews, quilts and embroiders brilliantly. You will love how smoothly it operates with its easy to use touch screen editing and more.

- Sewing and embroidery machine
- 100mm x 100mm embroidery area
- 125 embroidery designs Inc. 45 Disney designs
- NEW! Design combination
- NEW! Embroidery pattern drag & drop
- NEW! 3.2" Colour LCD touch screen
- 181 built-in stitches
- Automatic thread cutter
- 10 embroidery & 4 sewing fonts



£699
usual price
£899

Save
£200



LX17

Sewing machine

- 17 Built-in stitches
- Automatic 4 step button hole
- Drop in bobbin
- LED sewing light
- Free arm conversation
- Instructional DVD
- Softcover
- 3-year warranty



£119

FREE
Sewing
Machine
Carry Bag
worth £20

LX25

Sewing machine

- 25 Built-in stitches
- Automatic 4 step button hole
- Variable stitch length control
- Drop in bobbin
- LED sewing light
- Free arm conversation
- Instructional DVD
- Softcover
- 3-year warranty



£139

FREE
Sewing
Machine
Carry Bag
worth £20

XR27NT

Sewing machine

- 27 Built-in stitches
- LED sewing Light
- Automatic needle threader
- Automatic one step button hole
- Quick set bobbin
- Variable stitch length/width
- Drop feed
- 3 Year warranty
- Instructional DVD included



£189

FREE
Get going with
your sewing
machine
book

XR37NT

Sewing machine

- 37 Built-in stitches
- LED Light
- Automatic needle threader
- Automatic one step button hole
- Quick set bobbin
- Variable stitch length/width
- Drop feed
- Hard case
- 3 Year warranty
- Instructional DVD included



£209

FREE
Get going with
your sewing
machine
book

Innov-is 15

Sewing machine

- 16 built in stitches
- Back-lit LCD screen with digital stitch length and width controls
- Automatic needle threading system
- Start/Stop button and speed control
- 3 styles of 1-step automatic buttonhole
- Drop feed setting
- Quick set bobbin



£229

FREE
Sewing
Machine
Carry Bag
worth £20

Offers valid from 1st Oct to 31st Dec 2017



brothersewing.co.uk

brother
at your side

Innov-is sewing machines deliver simplicity without compromise.

Enjoy smooth strong feed on all types of fabric with a wide choice of decorative and utility stitches.

Innov-is 1800Q

Sewing and Quilting machine

- Large 8.3" (210 mm) work space to the right of the needle
- 234 built-in stitches, 10 styles of one step button holes
- 5 Styles of lettering upper and lowercase
- ICAPS - Continuous Automatic Pressure System
- My Custom Stitch – design your own stitches
- SFDS – Square Feed Drive System, delivers smooth strong feed
- Automatic thread cutter
- Combine and memorise stitches
- Sideways feed
- Knee lift
- Pivot function
- Slide speed control
- Includes large wide table
- Hard case



£999
usual price
£1,299

**SAVE
£300**

Innov-is F420

Sewing machine

- 140 built-in stitches, including 10 buttonhole styles
- 5 Styles of lettering (uppercase)
- Advanced needle threader
- Automatic thread cutter
- Lock stitch button
- SFDS: Square Feed Drive System
- Knee lift
- Memory function
- Needle up/down setting
- Quick-set bobbin and winder
- User-friendly LCD screen
- Hard case



£599

FREE
Creative Quilt kit
worth £149.99

OR

FREE
Couture Kit
and Creative
sewing pack
worth £144

Innov-is 27SE

Sewing machine

- Easy to use Electronic Jog dial, makes stitch selection simple
- 50 built-in stitches, 5 styles of 1-step automatic buttonhole
- Automatic needle threading system
- Drop feed - for free motion sewing
- Quick set bobbin
- Start/Stop button and speed control
- Hard Case
- 3-year warranty



£349

FREE
Creative Quilt kit
worth £149.99

Offers valid from 1st Oct to 31st Dec 2017



brothersewing.co.uk

brother
at your side

PR670E

NEW



- 6 Needle embroidery
- New 10.1" touch screen with advanced edition functions
- New industrial level acceleration
- Plus much more...

£5,999

FREE machine stand worth £399.99

PLUS Cap frame worth £859

OR

PE-Design 10 worth £999

Innov-is XV

Sewing, Quilting and Embroidery machine

SAVE £500



£5,999 usual price £6,499

PLUS FREE Premium upgrade package 1 worth £329.99

- 10.1" High-resolution IPS LCD touch screen
- Advanced intelligent camera eye system
- Super large embroidery area (9½ x 14", 240 x 360mm)
- 11¼" (285mm) long arm
- Scanning feature:
- Image scan
- Stipple and scan
- Auto Stipple
- Custom draw Stippling
- High speed sewing and embroidery up to 1050 stitches per minute
- Line art scanning (Draw it, Scan it, Convert it, Stitch it)
- Built-in tutorials
- Laser guide line for straight line sewing
- Direct dual feed foot

Innov-is V3

Embroidery machine



£1,999

FREE Premium upgrade package 1 and LED pointer embroidery foot worth £297.99

- Large 300mm x 180mm embroidery area – ideal for larger projects
- Large LCD touch screen – including on-screen editing for embroidery projects
- Thread sensors, auto-tensioning and easy threading for easy use and a professional finish
- Automatic thread cutting
- Quick-set drop-in bobbin and independent bobbin winding
- Over 200 built-in embroidery designs
- Full spectrum LED lighting
- USB ports – making it easy to import designs
- Fast 1050 stitches per minute embroidery speed

UK Dealer List

Scotland

David Drummond Edinburgh EH12 5HD 01315 397 766
 Karelia House Ltd Aberfeldy PH15 2LS 01887 822 027
 Pembertons Sewing Machines Stirling FK8 1HA 01786 462 993
 The Sewing Machine Shop Fochabers IV32 7DU 01343 823 961

North East

The Fat Quarters Newcastle upon Tyne NE17 7TN 01207 565 728
 Sewing Machine Sales Whitley Bay NE26 2SY 0191 2525 825
 Tullys Sewing Machines Sunderland SR1 3JG 0191 5657 995
 UK Sewing Machines Darlington DL3 7JY 01325 463 630

North West

Bamber Sewing Machines Ltd Eccles M30 7HY 0161 707 7786
 Cumbria Sewing & Craft Centre Barrow LA141DS 01229 823 714
 ETTY Lilly Bolton Le Sands LA5 8DB 01524 734 713
 Fabrics at Fleetwood Fleetwood FY7 6DU 01253 870 470
 Hobkirk's Sewing Machines Ltd Blackburn BB2 2AJ 01254 693 555
 Jaycotts Sewing Machines Chester CH1 4LT 01244 394 099
 Lord's Sew Knit Centre Accrington BB5 3DE 01254 389 171
 M&S Sewing Machines Heywood OL10 4NN 01706 366 943
 Superior Sewing Centre Carlisle CA3 8PW 01228 599 880
 Temptations Bentham LA2 7HQ 01524 261 868

Yorkshire & The Humber

A61 Woodseats Sewing Machines Ltd Sheffield S8 0RY 0114 255 2822
 Fabric Mouse Richmond DL10 7SN 01748 811593
 Gillies Fabrics York YO1 8SW 01904 626 244
 Grimsby Sewing & Knitting Grimsby DN32 9DR 01472 343 921
 Sewing Machines and Crafts Keighley BD21 1AD 0153 560 9466

Midlands

Brewers Sewing Machines Wolverhampton WV2 3AF 01902 458 885
 Couling Sewing Machines Lincoln LN5 8AW 01522 521 841
 Crafty Sew & So Leicester LE1 5DF 0116 319 6930
 Creative Hands 2 Worcester WR1 2LU 01905 249 40
 DC Nutt Sewing Machines Walsall WS3 3SS 01922 497 603
 GS UK Ltd Nottingham NG2 3DE 0115 844 8000
 Grain Sewing Machines Ltd Nottingham NG6 8UY 0115 927 1155
 L & M Nutt Sutton Coldfield B73 5BS 0121 373 5497
 The Lorna Knight Sewing Academy Leek ST13 7NX 01538 371 682
 Sewing Machine Centre Shrewsbury SY1 1XJ 01743 343 902
 Specialist Crafts Limited Leicester LE4 9HQ 0116 274 4730

East Anglia

Bedford Sew & Knit Limited Bedford MK41 7LE 01234 217 096
 Beccles Sewing Machines Beccles NR34 9TB 01502 714 234
 Franklins Group Limited Chelmsford CM2 0LG 01245 346 300
 Franklins Group Limited Colchester CO2 7DU 01206 563 955
 Franklins Group Limited Ipswich IP1 3EL 01473 221 188
 Sewing Machine World Kings Lynn PE30 5DD 01553 773 362
 Stitch X Stitch Stowmarket IP14 1HH 01449 257 070

Wales

Cliffords Sewing Machines Swansea SA1 3JY 01792 655 928
 J&B Sewing Machine Co Ltd Cardiff CF11 8AA 02922 402 418
 J&B Sewing Machine Co Ltd Newport NP19 4SY 01633 284 646
 Sewing Innovations Techsoft UK Ltd LL18 5TQ 01745 586 845
 Sewing Machine Direct Wrexham LL12 0PJ 08006 226 224

South East

Brighton Sewing Centre Brighton BN1 1YD 01273 621 653
 British Sewing Centre Boreham Wood WD6 1FJ 0208 236 1520
 C & A Supply Co Ltd Cranleigh GU6 8NE 01483 267 777
 CCB Sewing Machines Rochester ME1 1HS 01634 841 597
 Dowlings Wickford SS11 8YJ 01268 570 248
 Eastleigh Sewing Centre Eastleigh SO50 5LD 02380 650 808
 Emporia Fabric & Craft Ashford TN24 8RY 01233 612 278
 GTS Sewing Machines Banbury OX16 9PQ 01295 701 384
 Lewisham & Deptford S/Mcs Ltd London SE8 3NT 02086 921 077
 Maidstone Sewing Centre Maidstone ME14 1ED 01622 670 254
 Regent Home of Sewing Ilford IG1 2AG 0208 4780 669
 Rona Sewing Machines Waltham Cross EN8 7AP 01992 640 250
 Sew Devine Reading RG6 1JQ 01189 268 664
 The Sewing Centre London SW11 3BP 0207 228 3022
 The Sewing Shop Canterbury CT1 2HX 01227 457 723
 Sueco UK Portsmouth PO3 5BZ 02392 697 621
 Stitched By You Alton GU34 1BN 01420 544033
 Tysew Southall UB1 3AF 02085 741 750
 Wimbledon Sewing Machines Co. Ltd SW17 7AA 0208 767 0036
 Woking Sewing & K/M Centre Woking KT15 3NY 01932 352 958
 The World of Sewing Orpington BR6 75Q 01689 638 638
 The World of Sewing Tunbridge Wells TN1 2QP 01892 533 188

South West

And Sew to Knit Taunton TA1 1NZ 07547 006 618
 Caffle Crafts Weston Super Mare BS24 6SE 01934 838 327
 D & S Sewing Machines Newton Abbot TQ12 2BS 01626 369 840
 Exeter Sewing Machine Company Exeter EX1 2LD 01392 275 660
 Franklins Group Limited Salisbury SP2 7SU 01722 554 466
 Sewcraft Swindon SN1 1SD 01793 536 778
 The Sewing Studio Redruth TR15 2DB 01209 216 942
 White Orchid Corfe Mullen BH21 3UX 01202 886 001

Northern Ireland

Sew N Knit Belfast BT14 1AB 028 9045 6015

Offers valid from 1st Oct to 31st Dec 2017

brother
at your side



brothersewing.co.uk

This month I'm making

AUTUMN DUSTER COAT

Michelle put her sewing skills to the test with her version of Vogue 1467, as modelled by her sister! Keep up with Michelle's sewing journey at www.michellesews.com

Wine heavyweight
cotton drill dress
fabric, £8.99 per metre,
www.minervacrafts.com

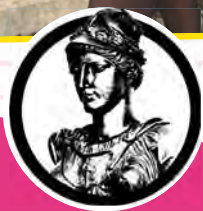

THE MINERVA CRAFTS BLOGGER NETWORK

The Minerva Crafts Blogger Network is a collection of amazing sewing and craft bloggers from across the world. Every month each blogger creates a unique kit from the thousands of gorgeous fabrics and notions available at Minerva Crafts. They wow us with their makes every month by blogging a project made with their kit on the network. There are new projects going live daily to inspire and educate sewists of all levels and abilities. Each blogger's unique kits are available to buy at www.minervacrafts.com

This month I bring you a tale of yet another project that strayed from its original plan but turned out well in the end! This project was originally going to be a Named Clothing Isla Trench Coat for my sister. It looks like a lovely pattern, and I'd seen some great versions on social media, so I decided to try it out. I ordered the heavy cotton drill and gorgeous check lining fabric, which I thought would work nicely against the wine-coloured outer fabric. I couldn't wait to get started...

And then I opened up the pattern. I was aware that the pattern would need to be traced, and seam allowances added by hand. What I hadn't anticipated was the weird nesting of pattern pieces randomly overlapping each other, and what I'm pretty sure was at least one pattern piece on which the line pattern for my size was incorrect compared to the others to further complicate matters. It gave me a headache, so I decided to use a pattern from my stash – Vogue 1467, obviously heavily modified!

Construction was pretty quick and easy. Because the fabric felt quite sturdy and I didn't have a collar or band to worry about there wasn't much interfacing to do. I used fusible stay tape around the neckline and front edges and interfaced the front facing. Annoyingly, I forgot to draft a separate lining pattern for the back, so I constructed the lining without a pleat at centre back. It's an open, loose coat though so hopefully shouldn't be under too much strain at centre back.

The sleeves are probably the most interesting part of the coat, and were easy to sew. I hand-stitched the lining sleeve around the top of the cuff, capturing the cuff seam allowance and giving it a clean finish inside. Well, relatively clean, if you ignore my doggy hand stitching!

The cotton isn't waterproof like the kind of treated cotton you might use for a proper trench coat but the colour has a subtle richness to it that I love; it reminded me of the berry-toned lipstick my sister swears by. The lining was easy to work with, pressed well, and as a taffeta lining it has a nice bit of 'weight' to it that made it easy to cut and sew but still feels lovely to wear. I'm happy to report the finished coat got the thumbs up from my sister, I'm sure you'll agree she looks fabulous in it!



Michelle says
The sleeves are probably the most interesting part of the coat, and were easy to sew



ABOUT *Kerry*

Kerry Green is co-author of *500 Quilt Blocks* and is a contributor to many other books and magazines. Find sewing tips, free tutorials, patterns and more at Kerry's blog www.verykerryberry.blogspot.co.uk

SWATCH SELECTOR

Fright night

Trick or treat, this fabric is ideal for year-round fun

October is all about Halloween, so whether you're sewing up costumes or stitching autumnal décor, I've chosen fabric with contrast and drama. There are bold graphic prints like the skulls, which can stand alone or mix with solids or blender fabric, and there's irresistibly cute designs like Lizzy House's Party Ghosts! Recent new releases include Robert Kaufman's Essex linen prints collection, Arroyo, designed by Erin Dollar and Cloud9 Fabrics's innovative range of yarn-dyed broadcloth metallic solids. The base cloth has great drape so it's definitely a dressmaking option as well as being suitable for quilting projects, plus there are lots of inspirational ideas on the website. Scot's plaid is an easy-to-sew quilt block and a great way to showcase a feature print. It also works very well on-point (rotated 90°). Here's a handy YouTube video with all the instructions you'll need to make an 8" block: www.youtube.com/watch?v=i_iAZCVIYW

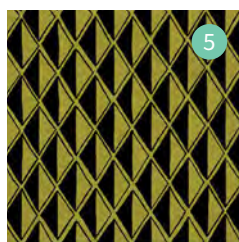
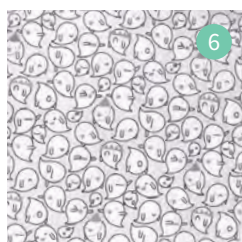
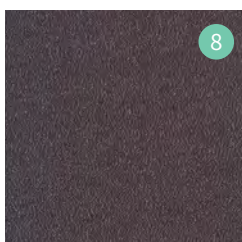
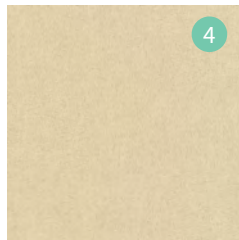
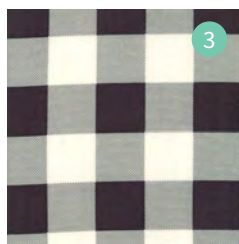
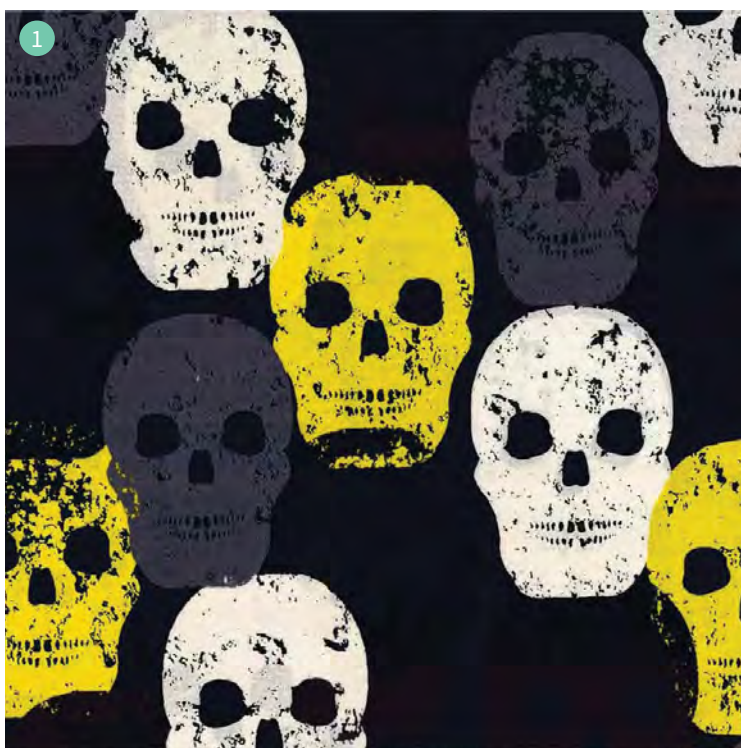
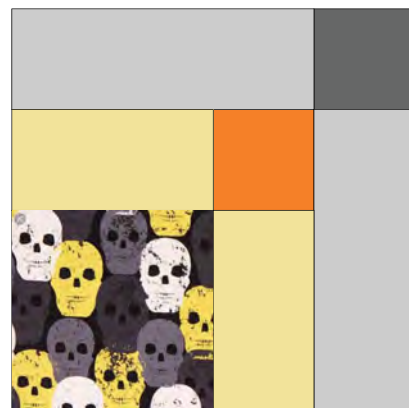

Shopping list

- 1 Michael Miller Skull of Rock Citron, £3.20 per FQ, www.plushaddict.co.uk
- 2 Windham Mischief Night Orange Bats, £3 per FQ, www.plushaddict.co.uk
- 3 Moda Hometown Christmas Collection Jumbo Plaid Ivory, £3.50 per FQ, www.eternalmaker.com
- 4 Cloud9 Fabrics Glimmer Solid Champagne Gold Metallic organic yarn-dyed broadcloth, £4.20 per FQ, www.misformake.co.uk
- 5 Robert Kaufman Arroyo, Diamonds in Pickle by Erin Dollar (55% linen 45% cotton), £5 per FQ, www.eternalmaker.com
- 6 Andover The Whisper Palette Grey Party Ghost by Lizzy House, £2.75 per FQ, www.oliveandflohcraft.co.uk
- 7 Riley Blake Penny Rose Trick or Treat Stripes Orange by Carta Bella, £3.20 per FQ, www.plushaddict.co.uk
- 8 Cloud9 Fabrics Glimmer Solid Graphite Metallic organic yarn-dyed broadcloth, £4.20 per FQ, www.misformake.co.uk

SCARLET *fever*

Add a dash of red into your wardrobe with this classic button-down skirt

Project **CLAIRE GARSIDE**



Shopping list

Red cotton spandex, £11 per metre
www.remnantkings.co.uk



SIZING:

	6	8	10	12	14	16	18
WAIST	25"	27"	29"	31"	33"	35"	37"
HIP	43"	45"	47"	49"	51"	53"	55"
LENGTH	21¼"	21¼"	21¼"	21¼"	21¼"	21¼"	21¼"

CUTTING:

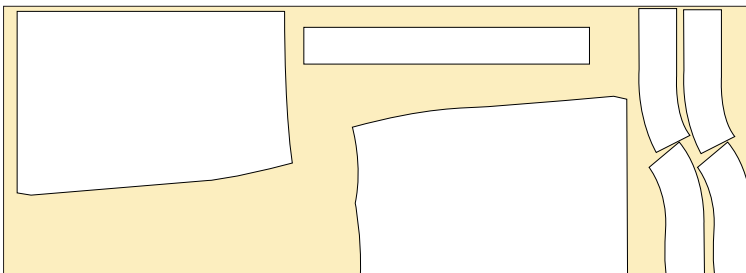

MATERIALS & TOOLS:

- 1.6m 45"-wide or 1.1m of 60"-wide fabric
- lightweight fusible interfacing
- 8 1.5-2cm buttons in diameter
- co-ordinating thread
- templates downloaded from www.lovesewingmag.co.uk

FABRIC SUGGESTIONS:

Medium-weight fabric such as cotton, sateen, barkcloth, wool and denim

Allow extra fabric for one-way designs and adjust layplan accordingly

NOTES:

1.5cm seam allowance is used throughout

We recommend finishing raw edges with a zigzag stitch or on an overlocker

HOW TO MAKE:

- 1 Sew in the darts on front and back skirt and press towards the centres.
- 2 With RST stitch the skirt together at side seams. (See Pic A.) Press the side seams open and top-stitch if you wish for a decorative finish.

3 Fuse lightweight interfacing to the WS of each button stand piece.

4 With RST attach the interfaced button stands to the front edges. (See Pic B.) For the seam allowance closest to the stand, grade to half the width to reduce bulk.

5 Press over the unsewn edge of each stand WST by 1cm and stitch the fold in place.

6 Press the stand seams open and then press flat back inside the skirt. Top-stitch close to folded edges if you wish.

7 Turn up the hem of the skirt and top-stitch in place. (See Pic C.)

8 Fuse lightweight interfacing to the WS of one set of waistband pieces.

9 With RST join the interfaced waistbands at the side seams and press the seams open. (See Pic D.) This will now be referred to as your waistband facing. Repeat for the second set of waistbands.

10 With RST sew the two waistbands together along the upper curved edge. Notch and grade the seam allowance to reduce bulk.



Amy says...

Why not make a wardrobe-staple denim skirt with contrast top-stitching?



Top tip
 Check the fit of the skirt before you begin by pinning together a tissue paper version of the pattern pieces

- 11 Zigzag or overlock the lower edge of the assembled waistband facing.
- 12 With RST attach the lower edge of the waistband to the upper edge of the skirt. (See Pic E.) Press the seam upwards so it will be trapped behind the facing.
- 13 Fold the waistband facing so it sits RST with the waistband and the lower edge overhangs the seam line. Sew up the short sides of the waistband in line with the finished front edges.
- 14 Clip the corners and turn through to the RS, using a point turner to get a crisp edge.
- 15 Stitch in the ditch of the waistband by sewing along the seam line from the RS. (See Pic F.)
- 16 Using a buttonhole foot, sew the buttonholes in the position marked on your pattern sheet. (See Pic G.)
- 17 Hand-sew your buttons in place to finish.

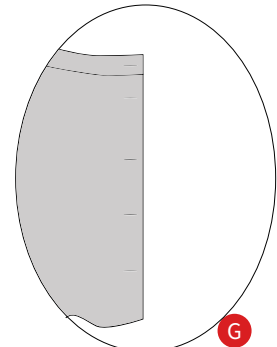
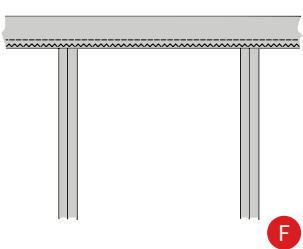
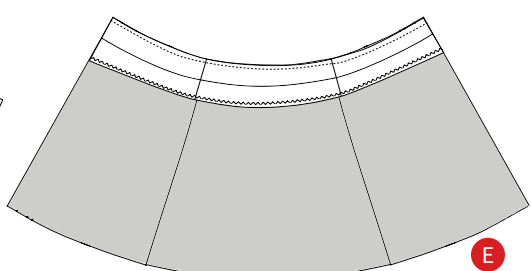
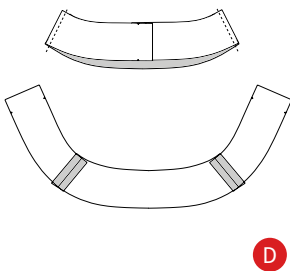
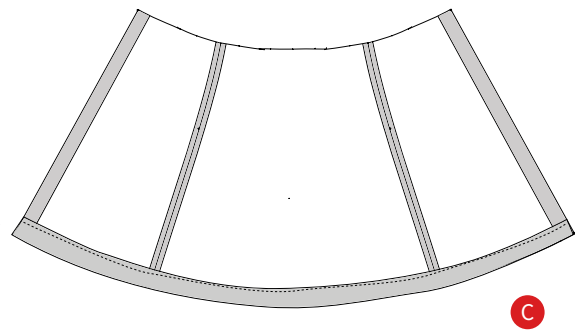
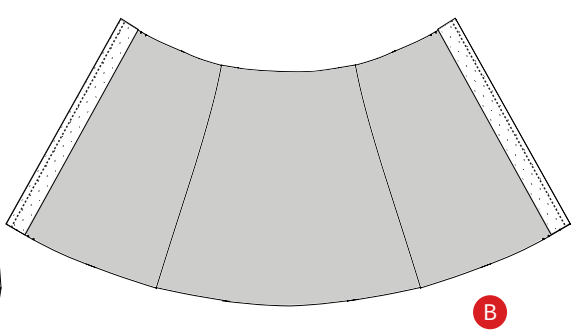
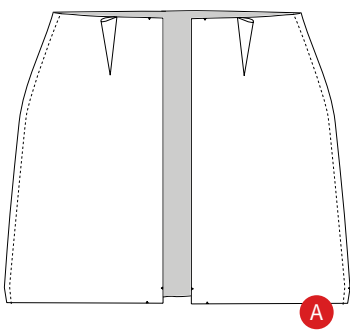

SEW IT Vintage

On sale 12th October!



Worth
£30

2 FREE
vintage
VOGUE PATTERNS



SEW A STYLISH
1940s pencil skirt



1930s Hollywood
ICON JACKET



QUICK-MAKE
party accessories

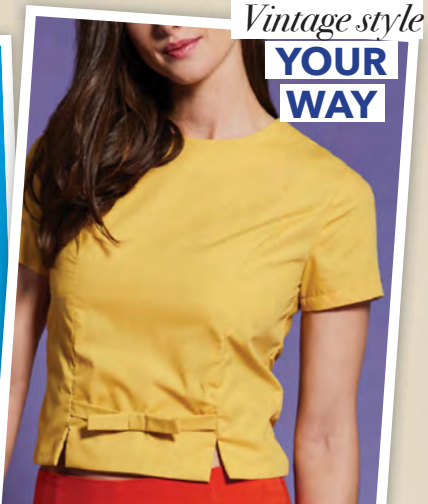

Vintage style
YOUR WAY

Order your copy today at www.moremags.com/sv1

moremags

ALL your favourite craft magazines and more!



DISCOUNTS & giveaways

Pretty sewing goodies, pattern tools and the chance to win a fantastic overlocker machine from Frank Nutt!

WIN A FABULOUS BROTHER 1034D OVERLOCKER!

The lovely team at Frank Nutt Sewing Machines has a special giveaway for our readers!

The Brother 1034D overlocker is the most popular model of 2017. It sews seams and trims excess fabric, has two needles and three or four threads with a differential feed system suitable for all types of fabric and home décor projects. You will be able to sew built-in rolled hems at the touch of a button, and decorative stitches are a breeze. It's a machine ideal for the sewist who wants to learn more, or who hasn't owned an overlocker before. It is easy to thread and use and comes with a tutorial DVD to get you started straight away.

Frank Nutt Sewing Machines is a family-run business dedicated to providing a high level of service and wide range of machines. To find your new machine, visit www.franknutt.co.uk

How to enter

For a chance to win any of this issue's giveaways, enter your details, along with the names of the products you would like to win, at www.ppjump.com/lovesewing45

T&Cs: By entering these competitions, you accept that your email address may be passed on to sponsors for marketing activities.
Closing date 9th November



WIN a selection of fabric from Birdy & Blue



Stocking a huge range of beautiful top-quality fabric, Birdy & Blue is THE shop for vibrant, exciting patterns. One winner will receive this fabulous array of materials to start their next project! Go to www.birdyandblue.co.uk to see the full range.



Win a selection of sequins from Sequins USA

One winner will receive a lovely selection of sequins. Sequins USA takes sequins seriously; it offers products you won't find anywhere else. Whether it's a garment for the ballroom, in the studio or just for adding the finishing touches to a project you'll find it at Sequins USA. View the full fantastic range at www.sequinsusa.com



WIN A MAYBERRY DRESS PATTERN FROM JENNIFER LAUREN HANDMADE

Five winners will each receive a downloadable Mayberry dress pattern. Mayberry's gently curved neckline leads to its distinctive off-centre button placket. This dress is your classic comfortable shirt-waist dress with a playful twist and is perfect for any occasion. Visit www.jenniferlaurenhandmade.store to see more gorgeous dress patterns.



WIN AN APPLIQUÉ MAT FROM HEMLINE

10 to win

Keeping your iron perfectly clean is the best way to avoid staining fabric, and extra care is needed especially when bonding fusible web to avoid sticky residue on your iron. This re-usable Teflon pressing mat will solve this problem, helping you get a good bond whilst also protecting your fabric. 10 lucky winners will each receive a mat. Contact groves@stockistenquiries.co.uk to find a store near you.



WIN tickets to the Knitting and Stitching show in Harrogate

10 lucky winners will receive a pair of tickets to the Knitting and Stitching Show in Harrogate. This event is the definitive event for anyone with a love of textile-based craft. The show takes place in the idyllic town of Harrogate and is the largest textiles event in the north of England, with hundreds of workshops, demonstrations, interactive features, professionally curated galleries and over 200 exhibitors selling specialist craft supplies. For more information, visit www.theknittingandstitchingshow.com/harrogate

HOW TO ENTER

For a chance to win any of this issue's giveaways, enter your details along with the names of the products you would like to win at www.ppjump.com/lovesewing45

By entering these competitions, you accept that your email address may be passed on to sponsors for marketing activities. Closing date 9th November 2017

WIN A SKETCH IT STITCH IT BOOK FROM MAKE IT BETTY



Win a pack of thread from Mettler

5 to win

We have 10 *Sketch it Stitch it* notebooks from Make It Betty up for grabs. The mastermind behind these awesome books is none other than our very own Bethany Armitage, Deputy Editor of *Love Sewing!* The books are here to help you to design your own crafty patterns, whether they're cross stitch, crochet or even quilting – it's totally up to you! Each A5 book is 48 pages (including covers) with 100% recycled cardstock covers and the inside pages are covered with a graph-paper print, containing 10x10 squares to an inch, providing the perfect backdrop for sketching out your own designs.

Head to www.makeitbetty.etsy.com to find a unique gift!

We have five packs of high-quality thread in an array of 18 vibrant colours to give away. The PS18 kit contains 18 beautiful colours in 200m lengths. Poly Sheen thread has a much larger surface area to reflect the light, making it shine beautifully. Go to www.eqasuk.com to see more of its products.



CLAIM YOUR FREE PATTERN

Whether you're out on the town or enjoying a get-together you'll be stunning in this garment. The pattern is loose-fitting with bias neck binding and is great for lightweight and woven fabric. We are offering this pattern to *Love Sewing* readers for free, just pay P&P. (While stocks last. One per customer.) To claim your free pattern, head to www.craftstash.co.uk/ls45readeroffer



10 to win

Win a fabric bundle from Girl Charlee



One lucky winner will receive a selection of beautifully patterned high-quality fabric to suit every sewing project. Girl Charlee Fabrics UK & Europe is the go-to online retailer and wholesale source for top-quality unique knit fabric. It offers exclusive knit fabric from Girl Charlee, as well as many other famous designer and top-quality prints and solids by the metre at the lowest prices! See more of its gorgeous fabric at www.girlcharlee.co.uk



Worth £100

Exclusive DISCOUNTS

SAVE 50% on selected Butterick patterns with the code **LOVESEWING45**. Turn to page 50 for more information. Offer expires 2nd Nov 2017

SAVE 15% on bouquets at Flying Flowers with the code **SEW15**. Go to www.flyingflowers.co.uk to see the beautiful range.

Offer expires 23:59pm on 30th November 2017. Offer applies to bouquets only, excluding Interflora, International, Help for Heroes, Prima, Good Housekeeping and subscription collections

SAVE 20% on selected sewing patterns at Fabric HQ with the code **LS45**, turn to page 9 for more information. Offer expires 10th Nov 2017

SAVE 15% on Jersey fabric with the code **SEW56** at Dragonfly Fabrics. Visit www.dragonflyfabrics.co.uk to take advantage of this great offer. Offer expires 10th Nov 2017.

SAVE 25% on any fabric online at Fabrics For Sale with the code **LOVESEW25**. Go to www.fabricsforsale.co.uk to see more. Offer expires 30th Nov 2017

SAVE 20% on jersey fabric at Higgs & Higgs with the code **LOVE40**. Turn to page 56 for more information. Offer expires 10th Nov 2017

WIN A GEMINI DIE-CUTTING MACHINE FROM CRAFTER'S COMPANION

Worth over
£150

One lucky winner will receive a Gemini die-cutting and embossing machine complete with fabric cutting dies. The Gemini machine is faster, lighter and quieter than other die-cutting machines and has been designed to cut intricate shapes as well as multiple layers of fabric. It uses high pressure to ensure better cutting of elaborate designs. The machine also enables edge-to-edge cutting of A4 and US letter-sized materials. It has the facility to pause, resume and reverse the plates within the machine and the large platform size means you can cut multiple dies at once. See more from Crafter's Companion at www.crafterscompanion.co.uk



Discover ideas and inspiration in a sewing paradise!



BUY 1 GET 1
FREE ON
TICKETS
book online
using code
LS10

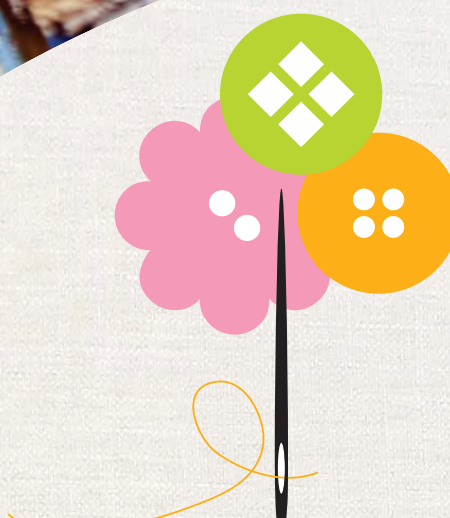

the
**STITCHING
SEWING
& HOBBYCRAFTS**
show

SEC, **Glasgow**

26 - 29 October

NEC, **Birmingham**

2 - 5 November

ExCeL, **London**

16 - 18 November



Crafting supplies • Haberdashery • Workshops
Demonstrations • Industry Experts
Feature Displays • Shop til you drop!

To book visit
www.ichfevents.co.uk

and use code **LS10** when purchasing
or call **01425 277 988** for more information

Terms and conditions: Phone lines open 9am-5pm Monday - Thursday, 9am-4.30pm Friday - standard tariffs apply. This offer is valid until 5pm on the Monday prior to each event opening and closes 5pm Monday 13 November 2017, cannot be used in conjunction with any other offer. Use code LS10 at check out

Connect the DOTS

This vintage-inspired design has bags of purse-onality, with a classic silhouette, large gusset and playful prints

Project & photography **ZAKKA WORKSHOP**

Top tip

A stiletto or tailor's awl is a small pointed tool used for piercing holes, pushing out corners and widening spaces!



MATERIALS & TOOLS

- 0.6x1m polka dot cotton/linen for purse outer
- fat quarter cotton/linen solid for accent fabric
- 0.6x1m cotton print for lining
- 0.2x0.6m medium-weight fusible interfacing
- 55x60cm fusible fleece
- 8x22cm round metal clasp
- 30cm paper string
- craft glue
- stiletto or tailor's awl
- pliers
- templates downloaded from www.lovesewingmag.co.uk

CUTTING

From the main fabric, cut:

- 2 purse outers
- 2 6x57cm handles (seam allowance is included)

MASTERCLASS

PURSE CLASPS

1 Prepare two pieces of string equal to the length of the clasp. Apply craft glue to the inner groove on half the metal clasp.

2 Insert the purse into the metal clasp, aligning the centre of the purse with the centre of the clasp. Use a stiletto or awl to insert one of the paper string pieces, starting at the centre.



3 On each side, make sure that the end of the seam aligns with the clasp hinge. Insert the ends of the paper string.

4 Cover the clasp with a scrap of wadding. Hold the clasp with pliers above the hinge and gently squeeze.



5 Insert the rest of the paper string following the numerical order shown.



6 Use the stiletto or awl to ensure the fabric is firmly in the clasp.



7 Let the glue dry and repeat for the other half of the purse clasp.



From the accent fabric, cut:

- 1 gusset

From the lining fabric, cut:

- 2 purse linings
- 1 gusset lining

From the medium-weight fusible interfacing, cut:

- 2 6x57cm handles (seam allowance is included)

From fusible fleece, cut:

- 2 purse outsides
- 1 gusset

NOTES:

All seam allowances are 6mm unless otherwise stated

Finished size approximately 32x21cm

HOW TO MAKE:

1 To make the handles, adhere fusible interfacing to WS of one handle. Fold the

short edges in by 1cm and press. Fold the long edges in by 1cm and press.

2 Fold the handle in half. Top-stitch the handle,

stitching as close to the edges as possible.

3 Repeat steps 2 and 3 to make the second handle.

4 To attach the handles, adhere fusible fleece to WS of each purse outside.

5 Top-stitch the handles to RS of purse outsides, following the placement indicated on the template.

6 To assemble the purse, begin by adhering fusible fleece to WS of the gusset.

7 With RST, sew one side of the gusset to one purse

outside, matching points A and C. Repeat this to sew the remaining side of the gusset to the remaining purse outside.

8 Repeat Step 7 to sew the gusset lining to the purse linings.

9 Insert the lining into the purse, with RST.

10 Sew together around the top, leaving a 12cm opening. Make sure to catch the gusset seam allowances when stitching.

11 Turn RS out through the opening. Fold the opening seam allowances in and top-stitch.

12 Install the metal clasp, following the masterclass above, to finish.

ABOUT THE BOOK



Adapted from *The Purse Clasp Book* by Zakka Workshop. £16.99 from www.zakkaworkshop.com

Support your local sewing shop

Spend £15 in participating stores to receive your **FREE** seven-pack of Gütermann Sew-all 150m thread worth £19!

WORTH £19*



Gütermann
creativ



JANOME

WIN

Shop at your local store and fill in the coupon on page 82 for a chance to win this fantastic prize

a £1,400 sewing room set!

You'll also be entered into our exclusive prize draw to WIN your dream sewing room set! **One lucky reader** will win an amazing Janome DKS100 Special Edition **sewing machine**, Horn Hobby **chair** and Storage 4 Crafts **sewing table**, worth £1,400!

Spend a minimum of £15 in any of the participating stores to be entered into this prize draw* You'll also get a seven-pack of Gütermann Sew-all 150m thread worth £19 with every entry!*
*Terms & conditions apply

BANBURY

Banbury Sewing Centre

57 Parsons Street,
Banbury, Oxon OX16 5NB
enquiries@banburysewingcentre.co.uk
Open 9-5 Mon-Sat

Supplying Fabrics, including Designer, Disney and Quilting. Patterns, Haberdashery, Lace, Trims, buttons and things. Knitting & Crochet accessories and yarns. Classes.

Telephone orders welcome
01295 262344

BEVERLEY



Sewing supplies & fabrics all under one roof! North Bar Fabrics in Cherry Burton is one of the leading fabric stockists in the area. Visit our store today and you will find exactly what you are looking for.

Bernina and Janome stockists

The Courtyard, Burton Mount,
Off Malton Road, Cherry Burton,
Beverley, HU17 7RA
info@northbarfabrics.co.uk
Call: 01964 551 955

BEXLEY HEATH



Sew Sew Fabrics, Bexleyheath
Unit 4, Rear of 39-41 Church Road, DA7 4DD

We stock a variety of fabric from just £3 per metre. Come along to our showroom or check out our classes and events at:

www.sewsewfabrics.co.uk/classes-events
Open Wed/Fri 9.30am-2.30pm
and Thur 7pm-9pm
info@sewsewfabrics.co.uk
www.sewsewfabrics.co.uk

BIRMINGHAM



Free Meter of fabric for the first 5 customers to place an order

Birmingham City Centre Sewing Studio & Tuition

212 The Jubilee Centre, 120 Pershore Street, Birmingham B5 6ND

Fabric and Haberdashery Shop specialising in amazing jerseys and luxury cotton lawns. Dashwood Jerseys now in stock
Tel 07917 536 220
www.sewcoolandcrafty.co.uk

CHEPSTOW



17 Moor Street,
Chepstow,
NP16 5DB

01291 627 056

An abundance of haberdashery awaits you. Fabrics, patterns, guttermann threads, DMC embroidery threads, gorgeous ribbons and buttons and more... alterations and curtain making too!



CHESHIRE

Blue Buttons Designs
djppproducts@msn.com
07540 634 351
Blue Buttons Designs Traders Outlet
3-7 Tatton Road, Sale,
Cheshire, M33 7EB

CLITHEROE

Patches and Buttons

Stocked to the Ceiling!



Fabric & patterns & habby Oh My...

www.patchesandbuttons.co.uk

25 Moor Lane, Clitheroe,

01200 423089

Tue - Sat 9.30-5.00

DURHAM

GOLDSTITCH

www.sewcafe.co.uk

- Premium Fabric
- Sewing Workshops
- Dressmaking
- Sewing Groups
- Embroidery

LIBERTY FABRIC STOCKIST



0191 3711444 Goldstitch, Tanhills, Durham, DH2 3PA

GRIMSBY



FriaryStitch Wool & Haberdashery

From Fabrics and Haberdashery, to Wool, Knitting and Crochet Accessories, we have it all here at Friary Stitch.

Come on in and take a look around!

2-4 Bethlehem Street
Grimsby, DN31 1JU

01472 357800

www.friarystitch.co.uk

HALIFAX



The Fabbadashery
Fabulous Fabrics, Beautiful Buttons and Truly Scrumptious Trimmings.
Craft Workshops Every Week!

hello@thefabbadashery.com
www.thefabbadashery.com
01422 647574

10-12 Clare Road, Halifax, HX1 2HX

HEREFORD

Badder Fabrics of Hereford

One stop shop for all your dressmaking needs
Patterns, fashion and bridal fabrics, dressmaking and alterations service

Husqvarna sewing machine sales and repairs on all models
Taking part in the Shop local giveaway campaign
36a Aubrey Street, Hereford HR4 0BU

Tel: 01432 379137
Email: badderfabric@gmail.com

MORPETH

AMBLE PIN CUSHION

www.amblepincushion.co.uk

Clothing repairs & alterations inc. bridal
Dry cleaning • Haberdashery • Wool • Fabric
Patterns • Craft supplies • Dressmaking
Millinery • Lampshades • Courses
Studio / craft room hire

20-22 Queen Street, Amble,
Northumberland, NE65 0BZ

T: 01665 714584

E: info@amblepincushion.co.uk

Open Mon to Sat 9.30am - 4pm
<https://www.facebook.com/amblepincushion>

NEWARK

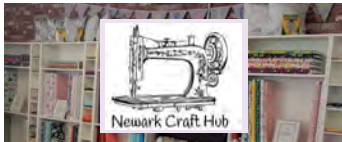

Home of Crafty Betty & The Fabric Daisy

Services we offer are: Workshops, Courses, Hen and Birthday Parties, Arts Award, After School Clubs, plus we have a retail area where we sell fabric and handcrafted goods.

www.newarkcrafthub.co.uk
01636 705909

NORFOLK



Fabrics and Haberdashery
Sewing patterns in stock
Ribbon, Lace and Trimmings
Alterations
Sewing classes and workshops
Free friendly advice

01366 387147
1 Lynn Road, Downham Market,
Norfolk PE34 3SB



NORTHALLERTON

Sew New Ltd

Your NEW one stop sewing shop!
Sewing workshops in dressmaking and crafts for all ages and abilities, Singer sewing machine sales and parts, Fabrics and haberdashery, Patterns and in-house pattern cutter.



Come and see us at Sew New Ltd.,
1, The Fairway, Romanby, Northallerton, DL7 8AY

Tel: 01609 531399

Email: info@sewnew.co.uk

Facebook: www.facebook.com/SewNew.co.uk
www.sewnew.co.uk

NORTHWICH

The Sew Easy Sewing Shop

Need haberdashery in Northwich?
Look no further than Sew Easy! We've a huge selection of fabric, needlecraft, sewing machines, patterns, and haberdashery products.

80 Witton Street, Northwich,
Cheshire, CW9 5AE

07952709910

www.seweasysewingshop.co.uk

Gütermann creativ



Why compromise?

www.guetermann.com

PRESTON



Welcome to my lovely craft emporium! We have lots of crafty goodies for sale however support, inspiration and the service with a smile are free!

Open 9.00am - 5.30pm Monday to Saturday

68 Berry Lane, Longridge, Preston, PR3 3WH
01772 780 883
www.itsofsewcrafty.com

SCOTLAND

Shop Local with Remnant Kings
Dressmaking & Quilting fabric, haberdashery, sewing patterns and everything else for your project
Glasgow - Edinburgh
Falkirk - Hamilton
www.remnantkings.co.uk

SCOTLAND

Holm Sown
FABRIC | HABERDASHERY | CLASSES
for DRESSMAKING, PATCHWORK AND QUILTING
222 King Street, Castle Douglas, Scotland, DG7 1DS
01556 505 359 | www.holmsown.co.uk

SHEFFIELD

Happy Hare

Sheffield's newest independent sewing store. We stock a wide range of fabrics, including Michael Miller, Riley Blake and Tula Pink. We also offer classes in a variety of crafts.



1a Arundel Road
Sheffield
S35 2RB
0114 2455996
handmadehappyhare@yahoo.co.uk

www.handmadehappyhare.com

SOUTHAMPTON

New Forest Fabrics
Fabulous fabrics for patchwork, dressmaking & crafts.
14 Shamrock Way, Hythe Marina Southampton. SO45 6DY
Tel: 02381 783386
Mon - Sat 10AM - 4PM
www.newforestfabrics.co.uk

STOKE-ON-TRENT

THE LORNA KNIGHT SEWING ACADEMY
Haberdashery
Sewing machines
Classes & workshops
Bradnop, nr Leek, ST13 7NX
07970 345628 / 01538 371682
www.lornaknight.com

SUFFOLK

Crafty Baba Fabrics
32 St Peters St, Ipswich
Over 1000 lines of fabric & haberdash
craftybaba.co.uk
Tel 01473 210636

SURREY

Sweet Seams
Sweet Seams Sewing Academy specialises in teaching people of all abilities to sew. Young sewers from 8 years. Teenagers group and Adult classes. Small classes + friendly environment = happy creative customers
Fabrics, haberdashery, patterns and handmade gifts.
41 Walton Road, East Molesey, Surrey, KT8 0DH
www.sweetseams.co.uk
07954 326495

FREE GIFT

from love Sewing

WORTH £19*



Claim your FREE Gütermann thread pack at one of these participating stores PLUS, be entered into our exclusive bumper prize draw*

Name.....

Address.....

Email.....

*Minimum in-store spend of £15 applies. To take advantage of this offer, please hand this voucher over the counter with your contact details completed. Your free Gütermann seven-pack of Sew-all 150m thread will be sent directly to you from Practical Publishing Ltd. Please ensure all your details are completed in black ink. By taking advantage of this offer you are agreeing to join the Practical Publishing Int Ltd e-newsletter list. You may opt out of this at any time. Your details will not be shared with any third-party companies. Please allow 2-4 weeks for your free thread to arrive. Available while stocks last. UK offer only. Only stores listed on pages 80-82 of Love Sewing 45 are participating in the thread and prize draw offer. Competition ends 15th March 2018.

love Sewing
THE UK'S NO.1 SEWING MAGAZINE
To advertise please contact
Noune on 0161 474 6997
or email noune.sarkissian@practicalpublishing.co.uk

READERS' MAKES



Carol Bailey

Another great Butterick 6318 – one of two free patterns with issue 43 of *Love Sewing*! Thanks for sharing Carol, you look lovely!

Simona Barlow

Simona made the McCall's 7533 dress from issue 40. She says, "I used scuba rather than woven and skipped the zip. It will get a lot of wear during the autumn months." Great job Simona.



Lydia

"My 17-year-old niece Lydia made herself the Annabelle dress from issue 34 using fabric she purchased on holiday." Thanks for sending in the pic Marion, Lydia looks stunning.



Star make



Sarah Middleton

Sarah Middleton tried out the Butterick 6318 pattern with issue 43 of *Love Sewing*. This is her daughter Bel modelling it beautifully, the fabric gives it a lovely vintage feel – gorgeous!

Send us your snaps!

TO WIN A

£25

FABRIC BUNDLE FROM MINERVA CRAFTS



Heather Arnatt

Butterick 6318 is stealing the show this month! Heather looks beautiful in her version with her fabric choice from Fabric Guild, Leicester.



Get in touch
letters@

practicalpublishing.co.uk

Leanne asked you...

In addition to your trusty sewing machine, which of the following do you use?

- A – COVERSTITCH
- B – OVERLOCKER
- C – EMBROIDERY MACHINE

B
68%

A
12%

C
20%

Beautiful BUTTONHOLES

Follow Wendy's simple steps that make sure you achieve perfect results every time

The buttonhole strikes fear into the heart of many sewists. With my handy tips you shouldn't be screaming at your sewing machine but instead will achieve beautifully made buttonholes.

MACHINE BUTTONHOLES STABILISING

1 It is essential to stabilise the buttonhole area to prevent stretchy or baggy buttonholes. With the correct stabiliser buttonholes can be successfully stitched in any fabric, from lightweight sheers to heavyweight or stretch knits. The aim is to prevent the concentrated stitching of the buttonhole puckering the fabric if it is lightweight or stretching it out of shape if it is a knit fabric. Most areas that require buttonholes are already interfaced, but if not, add a small square of tear-away stabiliser behind the area to be stitched to provide the stability needed.

NEEDLE AND THREAD

2 As the buttonhole is made of dense close stitching, penetrating at least three or more layers of fabric, you need a good sharp needle that can pierce through the layers easily. A new 80/12 is ideal for most woven fabric. But do remember to use a ballpoint/stretch needle

for stretchy fabric and a universal sharps for wovens.

Use the same general-purpose thread in both bobbin and as top thread for most garments. If sewing a heavyweight coat however, you can opt for special-purpose buttonhole thread that will create a very strong buttonhole. Once stitched, feed thread tails back through stitching before cutting off.

POSITION AND SIZE

3 Transfer the buttonhole position from the paper pattern to the fabric. If creating your own positioning, ensure that the start and end will be no closer than 15mm from the fabric edge.

You don't have to determine the size of the buttonhole required if your machine has the automatic buttonhole foot – usually a long white foot with two protruding lugs on the left side. Open out the recess and pop the button in place, then push to hold the button firmly. This sets the size for the buttonhole needed.

If your machine doesn't have this foot, you can stitch a buttonhole with a tight satin stitch but will need to mark the length on the fabric. To determine buttonhole size measure across the button and add 3mm. Note unusually shaped or domed buttonholes may require larger buttonholes. Test the size on a scrap of fabric to save heartache.

• Mark buttonhole placement with chalk lines or basting stitches. For horizontal buttons, draw two parallel lines the buttonhole size apart down the length to be buttoned. For vertical buttons, draw a vertical line from top to bottom of buttonhole placement and then mark buttonhole size with tiny horizontal lines. I use a different colour to mark the top and

bottom of each buttonhole.

- On average buttons should be placed approximately 2-3" (5-8 cm) apart on garments and 4-5" (10-13cm) on soft furnishings. On lightweight fabric, position them slightly closer.
- To open buttonhole, place a pin at one end close to inner edge of bar tack and, starting from other end, push the seam ripper towards pin, between side stitching.

BOUND BUTTONHOLES

Often found on tailored garments, coats or jackets, a bound buttonhole has flaps or lips each side of the opening. They can be fiddly to complete and are best avoided on fabric that frays easily.

1 To make a bound buttonhole, first cut a rectangle of fabric 5cm longer than the buttonhole. Fold it in half to create a crease through the centre. Then centre it over the buttonhole position on the RS of the garment and baste around the edge.

2 Mark buttonhole line along the centre crease, then mark a rectangle about 3mm away from the line all the way around.

3 Starting in the middle of the top line, machine-stitch the rectangle, counting the

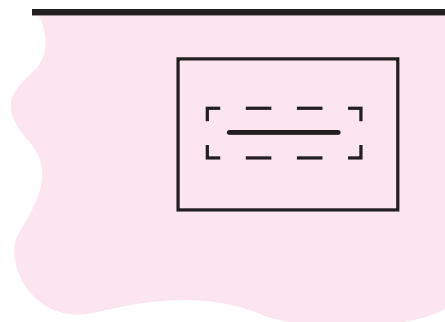

A beautifully stitched buttonhole can make a garment look so much more professional

Vogue pattern 8333

number of stitches taken on the short ends to ensure both are the same.

4 Using sharp embroidery scissors, snip into the buttonhole line in the centre and then cut along the line and diagonally towards the corners of the rectangle, taking care not to cut the stitching.

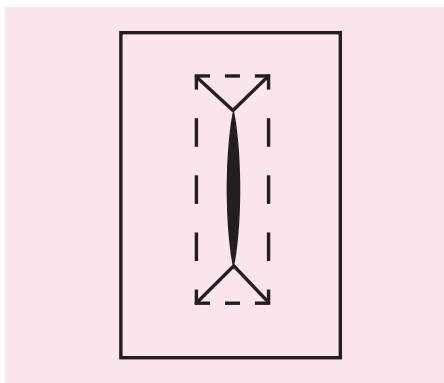

5 Push the patch through buttonhole, rolling the seam so it is on the very edge of the buttonhole. Press (you now have a rectangular hole).

6 Form the buttonhole lips by folding the long edges over the opening with folded edges meeting at the centre of the buttonhole. Check lips are neat and even from the RS and then baste to hold in place.

7 Working from the RS of garment, fold garment back along the side of the buttonhole to expose the ends of the patch. Stitch across the patch, through all layers, close to the garment fold. Repeat at the other end of the buttonhole.

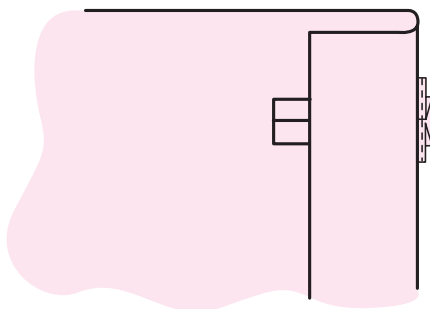

8 Do the same at top and bottom of buttonhole – fold garment back to expose patch and stitch inside original stitching line. Open out garment and press with press cloth.

Top tip!

Always test buttonholes on fabric scraps, with same fabric layers and interfacing prior to stitching on the garment



ABOUT WENDY GARDINER

As well as being Brand Ambassador for The McCall Pattern Company, Wendy is a published author and sewing teacher. Find her online courses at www.craftsy.com



ABOUT *Jade*

Jade Earley was a finalist on *The Great British Sewing Bee 2016* where she shared her love for sewing with the world. Follow her adventures online at www.thegirlwiththebrightredhair.co.uk

THE GIRL WITH THE BRIGHT *Red hair*

This issue Jade tells us all about her recent trip to The Great British Sewing Bee Live

This has probably been the best month of the year so far. Not only was it Sewing Bee Live, I am also very excited to announce that I will be teaching sewing at two of my local shops in Eastbourne; Stitch of Broad Street and Stitch of Compton Street. You all know how I love doing my tutorials – it's going to be wonderful to be able to meet people and teach them face to face.

Back to Sewing Bee Live. There are two words that I can use to describe the show: absolutely and amazing! I shared a flat with my mum, the lovely Joyce, the fabulous Tracey and the stunning Angeline. We had so many laughs and plenty of Prosecco was consumed. We stayed in a beautiful penthouse apartment

right near ExCel with amazing views over London. We went for a lovely meal on the Saturday along with some of the other Bees and it was great to catch up with them all. I'm sure you all know how it good it is when you get to spend time with friends you've been missing.

The venue for the show itself was amazing. I felt like I was in fabric heaven and brought back a huge amount; I just couldn't resist it! I think most sewists know this feeling when it comes to beautiful fabric. I must admit I was rather nervous about my workshops but I think they went pretty well all in all and it was lovely to be able to give all my students some little gifts as a thank you for booking on my workshops.

Being on a stage in the super theatre was nerve-racking to say the least. It was fab to work with a member of the audience on the alteration challenge (you all know this is not my specialty); it was like being back in the *Sewing Bee* sewing room again. It was lovely to catch up with Patrick and Esme and keep them up to date with all the things I've been doing since the show. I wish I could turn back time and have *The Great British Sewing Bee* experience all over again! Maybe if they do another series I could apply again under an alias and dye my hair blue!

The four days of the show passed so quickly and the whole thing was an amazing experience. I do



Did you meet Patrick Grant?

hope The Sewing Bee Live returns next year and I would love to be involved again. If any of you lovely readers attended I would love to hear what you thought about the show. Did you swoon over the lovely Patrick? It's always great to hear from like-minded sewing enthusiasts

As I said, September was a month to remember and I think it's going to take a while for me to come back down to earth now to get ready for Christmas and my upcoming holiday.

Happy sewing!



My favourite people all in one place!

3 ISSUES FOR £6

When you subscribe to

sew now



14 autumn essentials you'll love to sew

SEWING BEE LIVE
Get the inside scoop

TRICK OR TREAT
Costumes for all the family

YOUR 4-IN-1 PATTERN

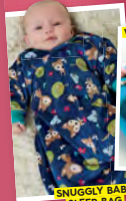

SNUGGLY BABY SLEEP BAG



FESTIVE WRISTLET PURSE



SEW YOUR new-season WARDROBE

THRIFTY SEWING
Save time & money

BEHIND THE SCENES
at Colette patterns

YOUR 2-IN-1 PATTERN



Quilted storage pouch

SKIRT IN THE SIZES 8-20

EX. WRA.

RETRO BEADED SHOPPER BAG



Every single issue comes with a dressmaking pattern WORTH OVER £8



SUITABLE FOR ALL SEWING ABILITIES

Every issue of *Sew Now* comes with a simple and stylish dressmaking pattern worth at least £8, offering inspiring designs to test your skills. *Sew Now* also caters to the growing trends for customisation and refashioning and is packed with home décor ideas to help you transform and personalise your home with fabric. Featuring home décor, upcycling and dressmaking content, *Sew Now* provides fabulous projects and ideas with an eye to keeping ahead of high-street trends.

SUBSCRIBE RISK FREE NOW

Online: www.practicalsubs.com/2410

Call: 01858 438899 (Quote code: SSNW1017)

Subscribe today,
offer expires 31/12/17

*Your first 3 issues are just £6, saving you 66%. Your Direct Debit will then automatically increase to just £12.49 per quarter, saving you 36% on the cover price of *Sew Now*.

ASK THE
EXPERTS

Lace skirt sew-along Part 2



In this issue Alison talks us through the tricky process of cutting out the lace!

If you have prepared your skirt, it's now time to cut the lace. I am using a beautiful guipure lace which has no net or organza backing. It is made up of a series of embroidered motifs linked by bars known as brides. The decorative edge of the lace runs along the selvedge, so the fabric is cut out with the selvedge (the decorative edge) following the hemline. Guipure lace is heavy and can be expensive so you want to do this right first time and not waste any precious fabric.

MOUNTING THE LACE



I placed the lace over the interlined and prepared skirt sections. The lace needs to be centred – this means the pattern needs to balance each side of the centre front and centre back. You may choose a dominant motif to run down the centre line. Lay the lace over the skirt panels, so the edge touches the tack line for the hem at the centres.

You will find as this is an A-line skirt that has a slightly curved hem, the lace overhangs the hem line at each end. DO NOT cut it off; leave it longer. Pin the lace to the skirt along the hemline and then around the edges. Cut out the lace, but leave the lace a little larger than the skirt at the side seams.

SHAPING THE LACE HEM



It may help you to fold the hem of the skirt in place, but do not stitch in place yet. Where the lace overhangs the hem, snip through the brides that join each shape to release the motifs. You can reposition the motifs above the fold of the hem before pinning.

Once you are happy with the lace placement, unfold the hem and, using small prick stitches, stitch around the repositioned motifs using matching thread. Stitch through to the skirt and then secure along the whole of the hem edge of the lace to the skirt.

SECURING THE LACE

As the lace is heavy, we also need to secure the lace at 10cm intervals working up from the hem toward the waist, mark rows with pins stopping before you get to the dart, which has not been sewn yet. Using the same small prick stitch work horizontal rows of stitches across the lace, securing it to the skirt.

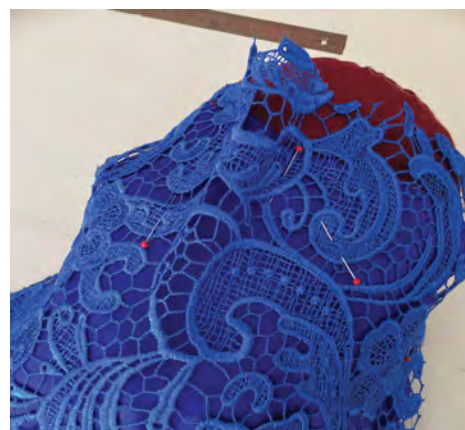

Fold back the lace and pin the dart in the under layer. Machine together and press toward CB or CF. You now have surplus lace in the dart area. Working over a ham, pin the lace to create a bubble where the dart is, then cut through the brides and once again mould the motifs over the shape made by the dart for a seamless finish. Repeat on all skirt panels.



Alison will be running a Couture Lace skirt workshop next year at her School of Sewing in Ashby-de-la-Zouch. The new schedule of workshop dates will be released on 21st October at www.schoolofsewing.co.uk

You have achieved quite a lot of couture work there! These are specialist techniques you can be proud to have learned.

Next time we will cover how to hand-insert the zip into the back of a lace skirt and join the skirt panels together.

Stay tuned for part 3!

ABOUT ALISON SMITH MBE

Awarded an MBE for her services to dressmaking, Alison is an industry expert in classic couture and a published author. Alison has her own shop and line of patterns, and you can also learn with Alison at one of her exclusive workshops. Find out more on her site www.schoolofsewing.co.uk



Claire-Louise Hardie

Shows you how to... READ A PATTERN



PATTERN CUTTING LINE

Each line relates to different size for the garment. There can be up to 10 sizes on a pattern sheet so you can either follow a single cutting line throughout or blend carefully between sizes to achieve a better fit.

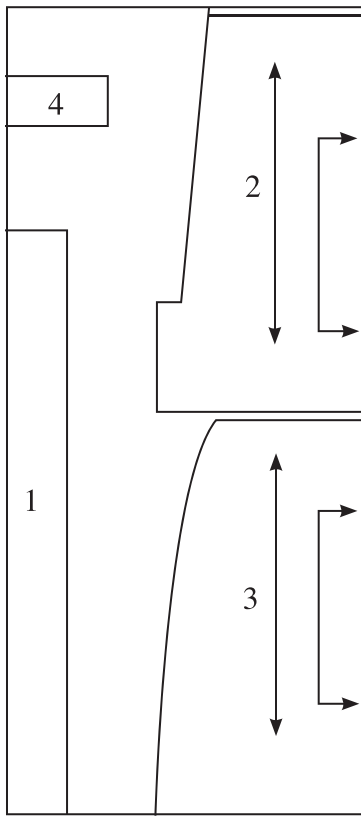

LAYOUT DIAGRAMS

These explain how to lay each piece onto the fabric to ensure that all of the pieces will fit on the fabric quantity suggested on the envelope. Remember to follow along with the correct view and size. Don't forget to take care with directional prints; you wouldn't want a floral print top with all the flowers upside down.



GRAINLINE

The arrow on the pattern piece must be 'on grain' with the threads of the fabric so that it can hang, move and stretch correctly. The grainline must always be parallel to the selvedge (the self-finished edges) of the fabric.



PLACE ON FOLD LINE

This edge of the pattern piece is to be placed on the fold of your fabric, making it easy to cut out a mirror image at the same time.

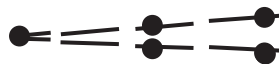

DARTS

Parts of the fabric to be folded for shaping, usually located at the bust, waist and neck.



NOTCHES

Make a tiny snip or chalk mark at each notch location, within the seam allowance. These marks are used to match pieces together before sewing.



LENGTHEN OR SHORTEN LINE

This indicates exactly where to shorten or lengthen the pattern piece or garment to make changes for improved fit.



CIRCLE DOTS

These marks indicate construction details, such as zipper position, pleating, or the end-of-stitching line, as set out in the instructions. Some pattern companies will use triangles or squares in place of circle dots.



BUTTON & BUTTONHOLE PLACEMENT

The placement for a button is marked with an X. The placement for a buttonhole is marked with an edged line.

TUCKS/PLEATS

Transfer any tuck lines marked on the pattern

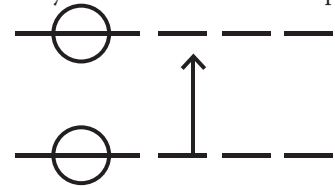

pieces to the RS (right side) of the garment. Follow directional arrows where given.

ABBREVIATIONS

SA (SEAM ALLOWANCE)

Every project you sew has a set seam allowance. This is the distance between where you sew and the raw edge of the fabric – essentially an invisible line around each pattern piece. These lines are occasionally included on vintage patterns. You must sew at the seam allowance in order for the pieces to line up correctly. Most commonly this is 1.5cm, but check your instructions in case smaller allowances are being used. Sewing machines have marks for the seam allowance to the right side of the presser foot.

RS (RIGHT SIDE AKA FABRIC FRONT)

Instructions for placing right sides of fabric together will be written as RST.

WS (WRONG SIDE AKA FABRIC BACK)

Instructions for fusing interfacing to the wrong side of fabric will be written as WST.

ACHIEVE THE PERFECT FIT

BUST ADJUSTMENTS

First, you need to work out how much additional space you require around the bust or what you'd like to remove. Here is a helpful chart to work out the amount:

	Small bust example	Full bust example
Full bust measurement	33"	38"
High bust measurement	32"	35"
Difference	1"	3"
Adjustment	½" SBA = half the difference	1½" FBA = half the difference

FULL BUST ADJUSTMENT (FIGS A-D)

- 1 Lay the tissue pattern against yourself to establish where your bust point is. Mark onto the pattern with a cross.
- 2 Using a ruler and pencil, draw a vertical line from the marked point to the hem. Make sure the line is parallel to the grainline on the pattern.
- 3 From this line, draw a second line up towards the armhole, hitting the lower third of the armhole. Together, these lines are called Line 1.
- 4 Draw a second line horizontally through the middle of the bust dart, meeting Line 1 at the bust point.

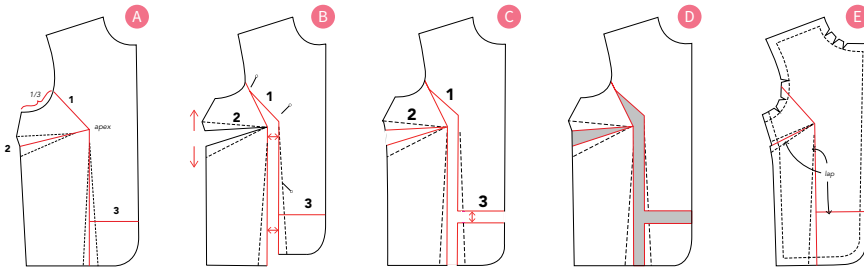

- 5 Draw a third horizontal line a little above the hem between Line 1 and the centre front of the pattern.
- 6 Cut along Line 1 from the hem to the armhole, making sure not to cut all the way through the armhole. Leave a hinge so you can pivot the paper. The point of the dart has now swung away from its original position.
- 7 Cut through the line in the middle of the dart, again leave a little hinge at the tip of the dart so you can pivot.
- 8 Line up the cut edges of Line 1 so they've been spread apart by the amount of your FBA. The edges should be parallel. You'll notice that your dart has now spread apart too and become bigger.
- 9 The lower edge of your hem no longer meets at the bottom, as the side that has been adjusted is now longer. Cut the third line you drew, and spread apart until your hem is level.
- 10 Fill in the spaces created with tracing paper, and stick into place.

SMALL BUST ADJUSTMENT (FIG E)

- 1 Draw in the lines as per an FBA adjustment. This is essentially the same process in reverse.
- 2 Swing the darted side of the pattern across the other side, by the desired SBA amount.
- 3 The lower edge of the hem no longer meets at the bottom, as the side that has been adjusted is now shorter. Cut the third line you drew, and overlap until your hem is level.

BACK ADJUSTMENTS

Some patterns will come with an adjustment line for narrow or broad back drawn on. If your pattern doesn't, you can easily do this yourself.

NARROW BACK (FIGS A - C)

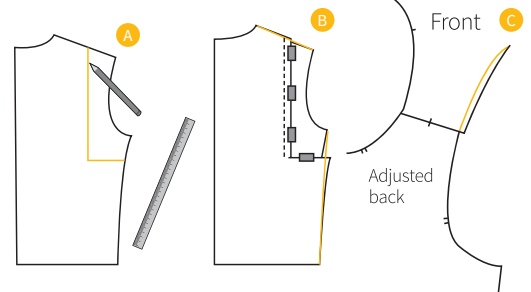

- 1 Draw a vertical line down from the shoulder, 3cm from the armhole to just below the bottom of the armhole. Draw a second line at a right angle from this point.
- 2 Cut along the two lines, and slide the armhole side overlapping the paper. Stick in place. A small ¼" adjustment is often enough. Play around with this amount as you develop your fitting skills.
- 3 Use a ruler and pencil to true up and re-draw the side seam and shoulder seam. Because we have only adjusted the upper back, the fit should remain the same around the waist. (See the orange lines on Fig B.)
- 4 You'll now need to make the front shoulder width a little shorter. Line up the notches on the shoulder ensuring sure the neckline is lined up. The front width will be a little longer than the newly adjusted back shoulder. Draw a new, narrower line from the back around the front, trimming a little of the front armhole away. Don't forget to make sure your new curved line is smooth at the shoulder.

BROAD BACK ADJUSTMENT (FIGS D AND E)

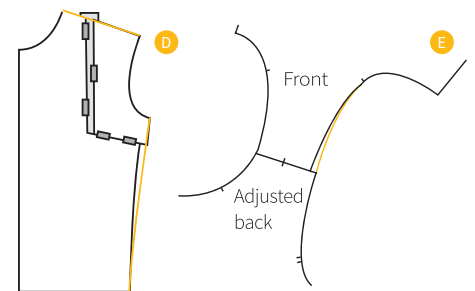

- 1 Start in the same way as a narrow back adjustment drawing the two lines and cutting along them.
- 2 Instead of overlapping the cut pattern pieces, spread them. As before there are no hard and fast rules, but with a broad back a ¼-½" adjustment is about right. Fill in the space with some tracing paper and stick together.
- 3 Use a ruler and a pencil to true up and re-draw the side seam and shoulder seam. (See the orange lines on Fig D.)
- 4 This time you'll need to make the front shoulder a little longer. As with the narrow adjustment, line up the shoulder seams, ensuring the neckline is aligned. Draw a curved line from the back shoulder down towards the front armhole, adding a sliver to the front shoulder and armhole. Check that you've drawn a smooth line over the shoulder.

ADJUSTING FOR HEIGHT

SHORTEN A PATTERN (FIG A)

Working at 90° to the grain, make corresponding tucks across the front and back bodice, at bust and below armhole. Make corresponding tucks across the front and back of skirt below the hips. For sleeves, shorten above and below the elbow, avoiding the sleeve head curve.

LENTHEN A PATTERN (FIG B)

Working at 90° to the grain, cut across the front and back bodice, at bust and below armhole. Cut across the front and back of skirt below the hips. For sleeves, cut above and below the elbow, avoiding the sleeve head curve. Spread the pattern pieces as required and fill the spaces with scrap paper.

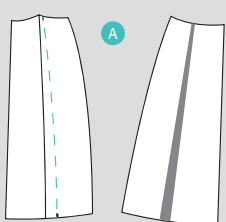
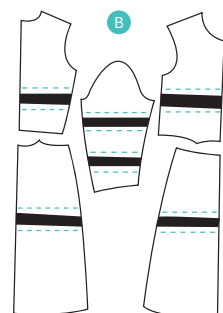
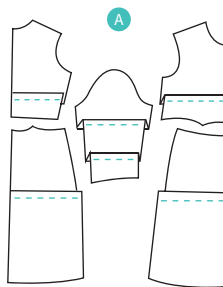

BELOW THE HIP ADJUSTMENTS (FIG A)

To decrease the width, make a graduated tuck from the waist to the hem, tapering to nothing at the waist, indicated by the dotted line.

To increase the width, cut the pattern piece through the waist to the hem, place over scrap paper and spread to the required size.

THE SEWING SHOP

Bristol

SEW EASY BRISTOL

Classes for all abilities including:

- Pattern cutting
- Bra or corset making
- Dressmaking
- Private tuition also available

Take a look at my website for my wide range of subjects
www.seweasybristol.com

07946176982
info@seweasybristol.com
www.facebook.com/SewEasyBristol



Cheam

Stitches HABERDASHELY & SEWING ROOM

16 Upper Mulgrave Road,
Cheam, SM2 7AZ
info@stitcheshaberdashery.co.uk
Tel: 0208 661 6040

Fabrics & Haberdashery Workshops & Parties

Stockists of Kaufman, Dashwood,
Windham, Sevenberry, & more...

Clitheroe

Patches and Buttons Stocked to the Ceiling!



Fabric & patterns & haby Oh My...

www.patchesandbuttons.co.uk

25 Moor Lane, Clitheroe,

01200 423089

Tue - Sat 9.30-5.00

Derby



Sewing Workshops • Sewing Parties and
Afternoon Teas • Sewing Club • Sewing Machine
Servicing and Repairs • Buy and sell second hand
machines • Children's Sewing Workshops • 1 to 1
Lessons • Customised Gifts and Items

See my website for more

www.sewnjo.com

Phone: 07760 330843

Markeaton Park Craft Village, Derby, DE22 3BG

Dumfries

Romy's Sewing Rooms

For all your haberdashery needs.
Sewing classes for all ages
and abilities.

180 Irish Street, Dumfries, DG1 2NJ

01387250867

romyssewingrooms@gmail.com

www.facebook.com/Romyssewingrooms



Hampshire

Reads of Winchester

Suppliers of sewing machines.
Janome, Elna, Bernina, Toyota, Jaguar
Both new and reconditioned.

Many machines on display
demonstrations available.

Sales service repair
haberdashery supplies

Tel 01962 850950

1 St Thomas Street,
Winchester, hants SO23 9HE
Open Monday to Saturday 9am to 5pm

Hampshire

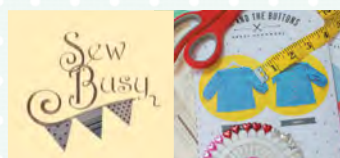

SEW BUSY

Stockists of Michael Miller, Riley Blake, Makower, Staf,
Tilda, Robert Kaufmann, Dashwood and others. Buttons,
haberdashery, patterns, unique gifts and craft workshops.

Branksomewood Road, Fleet, Hampshire GU51 4JS

Tel: 01252 444220

www.sew-busy.co.uk

Leicestershire



Visit us at...

THE SEWING CAFE

for SEWING WORKSHOPS,
FABRICS & HABERDASHERY

116 Castle Street, Hinckley,

Leicestershire, LE10 1DD

01455 698034 | www.thesewingcafe.co.uk

North Devon

Step By Step PATCHWORK CENTRE

11-12 George Arcade, South Molton, Devon,
EX36 3AB, 01769 574071

Patchwork and quilting supplies. Classes
and workshops.

Open 9am - 5pm Monday to Saturday

www.stepbystep-quilts.co.uk

Scotland

Holm Sown

10%
off fabric with
code: now10

modern fabrics and
sewing supplies

www.holmsown.co.uk

222 King Street, Castle Douglas, Scotland, DG7 1DS

Somerset

Mark Pickles' Sewing Studio

- Sewing classes
- Sewing Machines
- Large range of Fabrics
- Machine Sales
- Machine Service
- Machine Repairs

01225 482413

27 Charles Street, Bath, BA1 1HU

<http://husqvarnastudiobath.co.uk/>

m.pickles1@btintetnet.com

<https://www.facebook.com/sewingstudiobath/>

Stansted Essex



Teach Me to Sew

Sewing Classes for all

11 Brook Rd Stansted

CM24 8BB

www.teachmetosew.co.uk

tel. 07752209936

Tewksbury

Beckford Silk Made in England

Silks & velvet
Natural, printed
& dyed (over 60 colours)

Small quantities at
Wholesale prices
(min. 1/2m)

www.beckfordsilk.co.uk

01386 881507

Nr. Tewkesbury, Glos. GL20 7AU

Yorkshire

Happy Hare

Sheffield's newest independent sewing
store. We stock a wide range of fabrics,
including Michael Miller, Riley Blake and
Tula Pink. We also offer classes in a
variety of crafts.



1a Arundel Road

Sheffield

S35 2RB

0114 2455996

handmadehappyhare

@yahoo.co.uk

www.handmadehappyhare.com

Online only

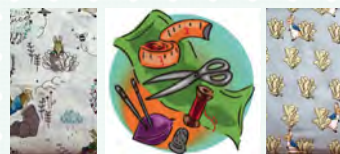

Molly Felicity Designs

original designs made with you in mind

Like our fabrics but want to make something
yourself? Molly Felicity Designs are now
offering vintage inspired fabrics and prints so
you can create something wonderful yourself

www.mollyfelicitydesigns.com

love Sewing

THE UK'S NO.1 SEWING MAGAZINE

To advertise please contact

Noune on 0161 474 6997

or email [noune.sarkissian@](mailto:noune.sarkissian@practicalpublishing.co.uk)

practicalpublishing.co.uk

STAR *make*

Snuggle in and sew a
stylish sweatshirt with
ribbed cuffs

Project **CLAIRE GARSIDE**

Shopping list

Glitter star sweatshirting silver on grey,
£19.99 per metre www.minervacrafts.com



Claire Garside

Simple Sew patterns offers British-designed sewing patterns in printed and PDF formats. See the full range, take a peek at what the blogger team has been making and find helpful tutorials and tips at www.simplesewpatterns.com

SIZING:

	8	10	12	14	16	18	20
BUST	38"	47.5"	57"	66½"	76"	85½"	95"
WAIST	38"	47.5"	57"	66½"	76"	85½"	95"
HIPS	40"	50"	60"	70"	80"	90"	100"

MATERIALS & TOOLS:

- 2.4m 45"-wide or 2.1m 60"-wide sweatshirting fabric
- 50cm contrast ribbing or cuff fabric
- co-ordinating thread
- templates downloaded from www.love sewingmag.co.uk

NOTES:

1.5cm seam allowance included around body and sleeves but use a 1cm seam allowance on the neckline and armholes.

HOW TO MAKE:

- 1 With RST, attach the front sleeve head to the bodice and then the back sleeve head to the back bodice. Repeat on the opposite side. (See Pic A.)
- 2 Arrange the sweatshirt with RST, and sew the side seams starting at the hem, pivot around the underarm and finish at the end of the sleeve. (See Pic B.)
- 3 Create a sleeve cuff by joining each sleeve cuff at the shorter edge, RST, and then fold in half WST lengthways. The cuff can be sewn in knitted rib or from sweatshirt fabric.

CUTTING:

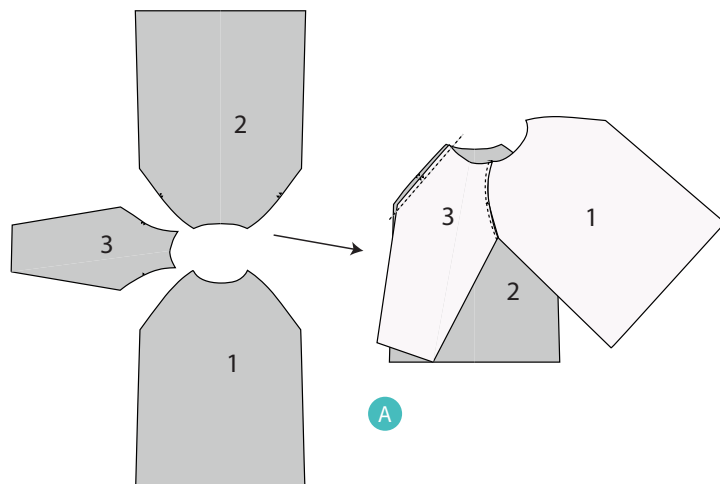
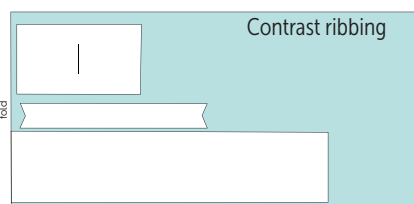

4 Attach the raw edge of the sleeve cuffs to the sleeves. (See Pic C.)

5 Create a hip band by joining the two hip pieces together at the shorter edges, RST, and then fold in half, WST.

6 Place the hip band RST with the hem of the sweater, aligning raw edges and sew. Press the seam up. (See Pic D.)

7 Join the neckline band at short edge with RST, then fold in half lengthways, WST.

8 RST, pin the raw edge of the neckline to the neckline opening on the sweatshirt. The first pinning point is on the left-hand side (when

worn) back sleeve seam, where the neckline rib seam is matched. Hold the pinned point with one hand and

use the other hand to stretch the rib to the opposite seam. Repeat the process for the centre point pins. (See Pic E.)

9 You now need to sew around the neckline, being careful to stretch

the cuff as you sew so that it fits the neckline on the bodice. The rib will pull in the neckline opening to create a smaller neckline. Press the neckline to neaten the edges. Follow our masterclass for additional tips and tricks!

Top tip
Why not try an overcast foot on your machine? It will create a replica of an overlocked seam finish

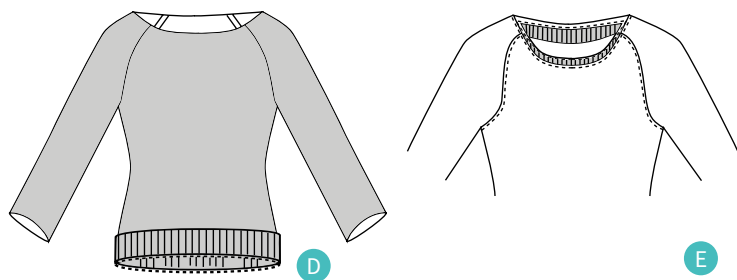
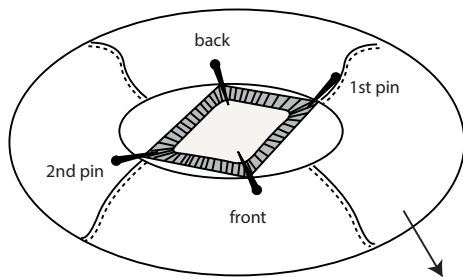
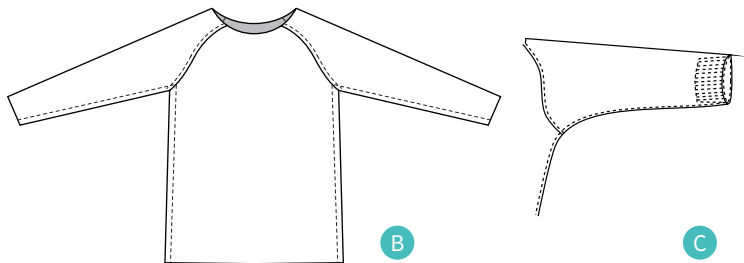

MASTERCLASS CUFFS & BANDS

Ribbed cuffs and bands finish your garment stylishly and make it easy to get on and off!

1 Take a square piece of fabric and cut neatly along the diagonal centre as shown.



2 Sew the two triangles you have created together and press the seam open.

3 Mark parallel rows in water-soluble marker that start 4cm from the edge. Try not to pull the fabric as you mark it as this will distort the bias.



4 Sew the unsewn edges together to form a loop of fabric, ensuring the marked lines match up as accurately

as possible. It may help to turn your work WS out to sew it, with your machine foot positioned inside the loop. Press the seam open.



5 Cut along the lines you marked with a small pair of needlework scissors.

6 Press your bias first along the long centre crease, then press each side towards the middle to create double-fold bias tape.



7 Now you can install your bias binding onto your garment.

Sizes
4-26

Next month in
love
Sewing

THE UK'S NO.1 SEWING MAGAZINE

TWO FREE

PATTERNS

worth over £17



McCall's 7322
6-in-1 top pack
Butterick 6461
easy-fit trousers

**Inspiring articles,
projects and guides:**

- ♥ *Relaxed boyfriend shirt*
- ♥ *Perfect party wear for every occasion*
- ♥ *Fun felt snow globe & decorations*
- ♥ *Festive embroidery inspiration*
- ♥ *Home for Christmas weekender bag*

Plus much more!



*Simple Sew
pleated dress*

**SIZES
8-20**



See
page 26
to
subscribe



Lovely Liberty
TABLETOP TREE



Reindeer games
SNUGGLY HAT



Playful polar bear
XMAS WREATH

Top tips and techniques from **Claire-Louise Hardie** ♥ Expert guidance from **Wendy Gardiner**
♥ Clever tutorials from **Elisalex de Castro Peake** ♥ In-depth articles from **Wendy Ward**
♥ Behind the scenes with **Jade Earley** ♥ Couture masterclass with **Alison Smith MBE**

Puppy

PATROL



These sweet doggies like nothing more than to go out for walks and to be admired. Why not tie a twine loop to transform them into paw-fect decorations?

Project **SALLY DIXON**

MATERIALS & TOOLS:

- 7.5x17.75cm Rust Brown felt
- 7.5x17.75cm white felt
- 3.25cm-square Chocolate Brown felt
- 2.5x5cm red felt
- 2cm square black felt
- 1.25cm square pale pink felt
- 2 0.3cm black round beads
- 10 silver seed beads
- brown, white, chocolate brown, red, black & pale pink embroidery floss
- Polyfill stuffing
- 2 2.5cm brooch pins
- 20cm twine (optional)
- templates downloaded from www.love sewingmag.co.uk

CUTTING:

From the rust brown felt, cut:

- 4 dachshund bodies

From the white felt, cut:

- 4 bull terrier bodies
- 1 bull terrier eye spot
- 2 bull terrier ears

From the Chocolate Brown felt, cut:

- 1 dachshund ear
- 1 bull terrier eye patch
- 3 bull terrier spots

From the red felt, cut:

- 1 dachshund collar

- 1 bull terrier collar

- 2 hearts

From the black felt, cut:

- 2 noses

From the pale pink felt, cut:

- 1 bull terrier inner ear (free-form or pattern)

NOTES:

Finished sizes:

- Dachshund brooch: 6x3x1cm
- Bull terrier brooch: 6x4x1cm

HOW TO MAKE:

DACHSHUND

1 Using one strand of black floss, sew a small black eye bead onto a dachshund body and appliqué the nose in place. With one strand of matching floss, whip-stitch the top of the dachshund ear in place.

2 Using two strands of red floss, sew the brooch pin firmly into place on the back of another dachshund body piece. Use a running stitch to attach a heart over the brooch pin base.

3 Place the four dachshund body pieces together, with the front piece on top

and the brooch piece on the back. Using two strands of matching floss, blanket-stitch around all four pieces. Before finishing, stuff the tummy with a small amount of Polyfill. Finish stitching and knot off.

4 Using one strand of red floss, whip-stitch the red collar in place and sew silver beads onto the collar. Knot off at the base of the collar.

BULL TERRIER

5 Using one strand of black floss, sew a small black eye bead, white eye spot, and brown bull terrier eye patch onto a bull terrier body. Appliqué the black nose, brown spots and pink inner ear onto the body.

6 Using the bull terrier pieces, follow the dachshund construction steps 2 and 3 to complete the brooch. Ensure you insert the two bull terrier ear pieces, layered and blanket-stitched together. Whip-stitch the ear in place through all the layers.

Top tip

Use one strand of matching floss for appliqué and running stitches, and two strands of matching floss for blanket stitches

ABOUT THE BOOK



Adapted from *Pipsqueaks* by Sally Dixon, £11.99 from www.ctpub.com

For more information on local stockists contact **01793 834304**. Our latest brochure can be downloaded now from;

www.hornfurniture.co.uk

The Horn *Maxi Eclipse*

*Need space to create?
Whether you're a Sewer or Quilter...
We've got it covered!*

Have a look at our full range online now...
...or contact us for a brochure



Arrives fitted with our 'Maxi-lifter' air-lift system (pictured) that can be customised to fit almost all brands of sewing machine. With this lift you may never need to lift or carry your sewing machine again.



You now have the option of upgrading to a push button electric lifter which will lift even the heaviest of sewing machines with ease. Contact us to find out where you can see one, you'll not be disappointed!



An inset, cut to fit your exact machine, is included. This gives you a perfect flat sewing position making the free arm of your machine level with the rest of the table top. Imagine - an ideal working height & **NO MORE NEEDLE DRAG!**



8 Large twin wheeled, lockable castors make it easy to move about even fully loaded.



Great storage potential as well as the ability to store your sewing machine and an overlocker or possibly a smaller portable machine.



With 5 lovely finishes to choose from, our service and our built in long lasting quality construction - finish off the perfect cabinet. It's what you've come to expect from Horn!



The ECLIPSE - Very compact when closed. Shown here in our clean white finish.

You can now have an Electric lifter fitted into this and 4 other of our models!

(See our latest brochure for more information and pricing)



Can't get to see the one you'd like?
Come see our range at an exhibition. Visit us at www.hornfurniture.co.uk/events/ to find out where we are next.....

£999

Every sewing machine should have one!

Your sewing room in a cabinet!

Horn
Crafting... Quilting... Sewing Furniture

www.hornfurniture.co.uk

(Please note: The sewing machine and accessories are not included)

AUTUMN 2017

Sewing with STYLE

AMAZING
AUTUMN
OFFERS!
£99 – £1,099

- AVON
BEDFORDSHIRE Direct Sewing Machines, Bristol – 0117 9778216
BSK Limited, Bedford – 01234 217096
My Sewing Basket, Dunstable – 01582 371127
Tudor Rose Patchwork, Oakley, Bedford – 01234 824983
Sew Devine, Reading – 0118 926 8664
- BERKSHIRE
BUCKINGHAMSHIRE Alans Sewing Machines, High Wycombe – 01494 527600
Threads and Patches, Milton Keynes – 01908 649687
- CAMBRIDGESHIRE Sew Creative Ltd, Cambridge – 01223 350691
Sew Much To Do, Ely – 01353 664 000
- CHESHIRE Allan Sheen Sewing Machines, Winsford – 01606 593554
All Fabrics, Stalybridge – 0161 478 8236/01706 624 651
Jaycotts, Chester – 01244 394099
J & P Sewing Machines, Warrington – 01925 633 831
Phil Morton Sewing Machines, Macclesfield – 01625 433 131
The Sewing Studio, Redruth – 01209 216942
Elegance, Derby – 01332 382292
Ilkeston Sewing & Janome Centre, Ilkeston – 01159 307664
Exeter Sewing Machine Company, Exeter – 01392 275 660
Soft Touch Needlecrafts, Tavistock – 01822 617673
- CORNWALL
DERBYSHIRE Bournemouth Sewing Machines, Bournemouth – 01202 424825
Hansons Fabrics, Sturminster Newton – 01258 472698
So N Sews, Weymouth – 01305 766 411
UK Sewing Machines, Darlington – 01325 463 630
Creative Lady, Burnham on Crouch – 01621 928 225
Franklins, Colchester – 01206 563955 & 574758
Franklins, Chelmsford – 01245 346300
Home of Sewing by Regent, Ilford – 0208 478 0669
Superstitch Machine Co, Leigh on Sea – 01702 478830
- GLOUCESTERSHIRE Cotswold Sewing Machines, Stroud – 01453 763660
West End Sewing Centre, Cheltenham – 01242 244025
- HAMPSHIRE Eastleigh Sewing Centre, Eastleigh – 02380 650 808
Hampshire Sewing Machines, Fareham – 01329 280499
Reads of Winchester, Winchester – 01962 850 950
Sew Creative, Petersfield – 01730 858020
Badder Fabrics, Hereford – 01432 379137
- HEREFORDSHIRE
HERTFORDSHIRE Chicks Embroidery, Letchworth – 01462 670 007
Rebecca Woollard Sewing School, Hatfield Heath – 07887 654 717
Rona Sewing Machines, Waltham Cross – 01992 640250
Sewfine Sewing Machines, Watford – 01923 693734
- KENT Ashford Sewing Centre, Ashford – 01233 620948
Barcham Sewing Centre, Whitstable – 01227 264 271
Maidstone Sewing Centre, Maidstone – 01622 670 254
The Sewing Space, Kent – 01303 261329
The World of Sewing, Tunbridge Wells – 01892 533188
- LANCASHIRE ETTY-LILLY, Carnforth – 01524 734713
Hobkirk Sewing Machines, Blackburn – 01254 693555
Lestan Sewing Machines, Nelson – 01282 614511
M & S Sewing Machines, Heywood – 01706 624651 & 366943
R. Bullock & Son Ltd, Wigan – 01942 247836
Transworld Sewing Machines, Leigh – 01942 608028
- LEICESTERSHIRE Cresswell Sewing Machines, Leicester – 07979 798 010
The Sewing Café, Hinkley – 01455 698 034
- LINCOLNSHIRE Couling Sewing Machines, Lincoln – 01522 521841
Seweezy, Gainsborough – 01427 614570
- LONDON (GTR) All London Sewing, South West London – 0208 3373444
Lewisham & Deptford Sewing Machines, Deptford – 0208 692 1077
SM Sewing Machines Ltd, London – 0208 4524257
The Sewing Centre, Battersea – 0207 228 3022
The World of Sewing, Pratts Bottom – 01689 638638
Wimbledon Sewing Machine Co Ltd, Tooting Bec – 020 8767 0036
- MANCHESTER (GTR)
MERSEYSIDE Bamber Sewing Machines, Manchester – 0161 707 7786
Affordable Sewing, Moreton, Wirral – 0151 677 7755
Sewing & Knitting Centre, Southport – 01704 534688
Sew Creative, Norwich – 01603 305888
Sewing Machine World, Kings Lynn – 01553 773362
Sew Northampton, Northampton – 01604 637200
- NORFOLK Cresswell Sewing Machines, Nottingham – 0115 9267572
Witney Sewing Machine Centre, Witney – 01993 704535
Sewing Machine Centre, Shrewsbury – 01743 343902
- NORTHAMPTONSHIRE
NOTTINGHAMSHIRE Bredons Sewing Machines, Taunton – 01823 272450
Franklins, Ipswich – 01473 221188
Sew Much To Do, Bury St Edmunds – 01284 755459
All Redgwell Sewing, Worcester Park – 0208 3373444
C & A Sewing Machines, Cranleigh – 01483 267777
Discount Sewing Machines, Lightwater – 01932 349000
Woking Sewing Centre, Addlestone – 01932 352606
Woking Sewing Centre, Newhaw – 01932 352958
- OXFORDSHIRE
SHROPSHIRE Clothkits Ltd, Chichester – 01243 533180
Eclectic Maker, Worthing – 01903 681000
Hastings Sewing Centre, Hastings – 01424 423108
- SOMERSET
SUFFOLK G Tully Sewing Machines, Sunderland – 0191 565 7995
Sewing Machine Sales, Whitley Bay – 0191 2525825
Coventry Sewing Centre, Coventry – 02476 222134
Franklins, Salisbury – 01722 554466
Nimble Thimbles, Swindon – 01793 950 750
- SURREY Brewers Sewing Machines, Wolverhampton – 01902 458885
D C Nutt Sewing Machines, Walsall – 01922 497603
Frank Nutt, Kings Heath – 0121 444 3978
L & M Nutt, Sutton Coldfield – 0121 373 5497
S Nutt Sewing Machines, Birmingham – 0121 327 2828
- SUSSEX
- TYNE & WEAR
- WARWICKSHIRE
WILTSHIRE
- WEST MIDLANDS



BRAND
NEW OFFER
£299

MODEL 230DC

- FULLY COMPUTERISED
- 30 stitch choices
- 3 styles of auto 1-step buttonholes
- Jam proof drop in bobbin
- Auto needle threader

Easy to use... Make the right choice first time!

WORCESTERSHIRE

- Creative Hands 2, Worcester – 01905 24940
- Inkberrow Design Centre, Redditch – 01527 69100
- A1 Woodseats Sewing Machines, Sheffield – 0114 2552822
- Arcade Sewing Machines, Huddersfield – 01484 429808
- C & G Sewing Machines, Bradford – 01274 306352
- Electra (DA) Company, Doncaster – 01302 340 369
- Fabric Mouse, Catterick – 0800 6889971
- Flynn's Sewing Centre, York – 01904 692999
- Sewing Centre, Scarborough – 01723 363167
- White Rose Sewing Machines, Harrogate – 01423 503767

CHANNEL ISLANDS

- Rachel's Textiles Studio, Jersey – 01534 878 877
- Joan's Wools & Crafts, Onchan – 01624 626 009
- Sew N Knit Belfast, Belfast – 028 9045 6015
- Sew N Knit Lisburn, Lisburn – 028 9267 0908

ISLE OF MAN IRELAND

- Singer Sewing Centre, Ballymena – 028 2564 0034
- David Drummond, Edinburgh – 0131 539 7766
- Pemberton's Sewing Machines, Stirling – 01786 462993
- Quilt Creations, Inverness – 01463 719369
- Sew Materialistic, Ayr – 01292 280844
- Sew Yarn Crafty! Dunfermline – 01383 723995

SCOTLAND

- The Sewing Machine Shop, Fochabers – 01343 823961
- Butterfly Fabrics, Cardiff – 02920 470808
- Clare Sewing Machine Shop, Aberystwyth – 01970 617786
- Cliffords Sewing Machines Ltd, Swansea – 01792 655 928
- J & B Sewing Machine Co Ltd, Cardiff – 02922 402418
- J & B Sewing Machine Co, Ltd, Newport – 01633 281555
- Sewing Machines Direct, Wrexham – 01978 851 235

WALES

The 'Sewing with Style' offers are available from Janome sewing machine retail outlets nationwide. Promotion starts **4th September until 2nd January 2018**. (All offers subject to stock availability.)

