

Woodsmith®

Feature Projects:

OAK DESK

DESK CLOCK

IN/OUT BOX



Tool Review:

SHOULDER PLANES

Woodsmith



Editor Donald B. Peschke
 Managing Editor Douglas L. Hicks
 Assistant Editors James M. Dolan
 Gordon Gaipe
 Philip A. Totten
 Tim Robertson

Contributing Editor Richard S. Peters

Creative Director Ted Kralicek
 Assistant Art Director Rod Stoakes
 Senior Illustrators David Kreyling
 Chris Glowacki

Illustrators Dirk Ver Steeg
 Cinda Shambaugh
 Robert H. Whitmer

Photographer Crayola England
 Design Director Ken Munkel
 Asst. Designer Jan Hale Svec
 Shop Manager Steve Curtis

Circulation Director Liz Bredeson
 Subscription Manager Sandy Baum
 Circulation Analyst Jim Woodson
 Newsstand Sales Kent A. Buckton

CORPORATE SERVICES

Controller Paul E. Gray
 Accounting Linda O'Rourke
 Bookkeeping Julianne Spears
 Network Administrator Douglas M. Lidster
 Administrative Asst. Cheryl A. Scott
 Receptionist Lori Seibert
 Building Maintenance Ken Griffith
 Archie Krause

WOODSMITH SOURCEBOOK

Marketing Director Robert Murry
 Art Director Cindy McNelly-Jackson
 Customer Service Mgr. Laura Bathe-McNelly
 Project Supplies Leslie Ann Gearhart
 Linda Jones
 Technical Support Jonathan Garbison
 Advertising Jean Myers
 Systems Operator Linda Morrow
 Receptionist Keri Lee
 Customer Service Shipping Department
 Jennie Enos Jerry Carson, Supv.
 Joy Johnson Gloria Sheehan
 Tammi Juhl Ronald Long
 Doug Neathery Donnie McVey
 Jeff Janes Chuck Carlson

STORE MANAGERS

Des Moines, IA Kent Welsh
 Berkeley, CA Michael DeHaven

Woodsmith (ISSN 0164-4114) is published bi-monthly (Feb., April, June, Aug., Oct., Dec.) by Woodsmith Corporation, 2200 Grand Ave., Des Moines, IA 50312. Printed in U.S.A.

Woodsmith is a registered trademark of Woodsmith Corp. ©Copyright 1992 by Woodsmith Corp. All rights reserved. Subscriptions: Single copy: \$3.95. One year subscription (6 issues), \$17.95. Two years (12 issues), \$31.95. (Canada/Foreign \$21.95 per year, U.S. funds.)

Second Class Postage Paid at Des Moines, IA and at additional offices.

Postmaster: Send change of address to Woodsmith, Box 10718, Des Moines, IA 50350.

Subscription Questions? Call 1-800-333-5075, 8:00 am to 5:00 pm, Central Time, weekdays.

Sawdust

What do you think about the new look? This is our first full-color issue of *Woodsmith*. Up to now, *Woodsmith* has been printed in two colors (brown and black) on a buff-colored paper.

I've always wanted to be able to show the projects in color, but it seemed like a big change. One thing I've found over the years is that woodworkers usually have opinions, and aren't reluctant to express them. So, whenever someone would drop by the office for a tour, or I'd be at a woodworking show, I'd ask, "What do you think about *Woodsmith* being printed in full-color?"

The answer was almost always the same, "Don't change a thing. It looks good just the way it is."

But I still wanted to see what a color version of *Woodsmith* would look like. So, we printed some special copies of one issue in full color and sent it to 1,000 readers for a side-by-side comparison with the regular two-color version.

Again, almost everyone agreed . . . but this time they said they liked the color version better. (In fact, 91% said they preferred the full-color version to the two-color.)

Why this big change in attitude?

I think that a full-color magazine carries with it certain perceptions. White glossy paper. Advertising. And maybe increased costs. Nobody wanted those things.

Just in case you're wondering, we will *not* be increasing the cost of a subscription because of this move to color. (It's more dependent on future increases in postage and paper costs.) And we will definitely *not* carry any advertising in *Woodsmith*. (Although we will have some advertising in the *Sourcebook* that comes with your issue.)

I didn't mean to spend a lot of time talking about this new color look . . . but to tell the truth, I wish we had done it a long time ago. I really like to see the projects in color.

OLD WAYS. Sometimes moving to a new way of doing things is good. But there are times when the old ways are still the best. I like our move to color to show off the projects. But when it comes to working in the shop, I don't want to give up my hand planes.

With all the new tools on the market today (most with motors on them), I still think hand planes can't be replaced. We have an article in this issue on shoulder planes and their uses.

If you haven't tried using one of these planes, it's worth the time to experiment with one. I can almost guarantee that it won't be long before you get enthusiastic about working with planes.

I don't mean to sound too romantic, but having a good set of hand planes and knowing how to use them is one of the real joys of woodworking.

DESK. We wanted to start off our 14th year with a great project. The Pedestal Desk is one I've been wanting to build for years. It's quite a project, and takes a good bit of time to complete.

The interesting part of a major project like this is that it doesn't really require a tremendous amount of skill. Each step, when broken down, is fairly easy to accomplish. But what this project does require is commitment. There's a lot of work here and you just have to keep at it.

TECHNIQUE. Probably the most intriguing technique in this issue is the one we used on the In/Out Box to make the round-cornered box joints.

Ted figured out a way to make a true rounded corner on box joints. That is, the corner is rounded on the outside (that's the easy part), but it's also rounded on the inside (see page 18).

NEW FACES. I have to mention the color photos in this issue one more time. The reason is our new staff photographer, Crayola England. You've actually seen Crayola's work for the past couple of years. (She's been working on a freelance basis with Ted.) But with the addition of our new publication, *ShopNotes*, and the expansion of the *Sourcebook*, we've asked her to join us full time. (Everyone asks, so I have to say that Crayola is her real name.)

GROWTH. With this issue, we begin our 14th year of publishing *Woodsmith*. Each year we're required by the U.S. Post Office to print the Publisher's Statement (see page 27). It shows that we've grown quite a bit during the past year. Last year we averaged about 292,000 circulation, and this year it's up to about 352,000. It seems a lot more people are getting interested in woodworking. We're glad to be part of that growth and think it will continue in the future.

NEXT MAILING. The next issue of *Woodsmith* (No. 80) will be mailed during the last week in March 1992.

Contents

Tips & Techniques

4 *Great tips from fellow woodworkers. 1) Table Saw Jointing. 2) Crosscut Jig. 3) Putty Knife Scraper. 4) Grinding Stop Gauge. 5) Two Quick Tips. 6) Scroll Saw Tips.*

Pedestal Desk

6 *This desk is a classic that has it all: solid oak frames with oak plywood panels, dovetail drawers, a large file drawer, and a top with in-laid walnut strips. There's even an optional vanity panel.*

Shop Notes

16 *1) Cutting a Coped Joint. 2) Shop-Made Drawer Pulls.*

In/Out Box

18 *Box-joined corners on this desk box are rounded over on both the outside and the inside to produce the effect of bent fingers. It's an interesting variation on a basic joinery technique.*

Shoulder Planes

22 *These specialty hand planes can produce tight-fitting joints by picking up where machines leave off. We discuss how to set up a shoulder plane and then use it. And, some recommendations on which ones are best for your purposes.*

Talking Shop

26 *1) Hand Plane Numbering Systems. 2) Tips on Using Double-Sided Carpet Tape in the Shop. 3) Router Bit Maintenance.*

Desk Clock

28 *Hidden in the base of this miniature architectural timepiece is a storage chamber for business cards or desk items. It's a great weekend project.*

Sources

31 *Hardware and project supplies needed for the projects in this issue.*



Pedestal Desk

page 6

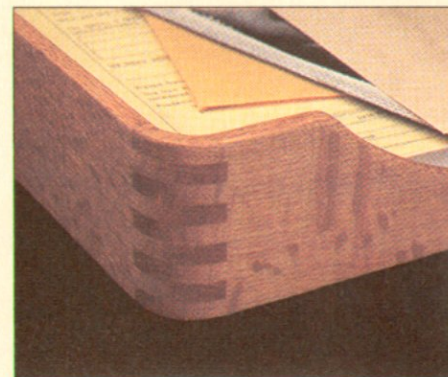

In/Out Box

page 18

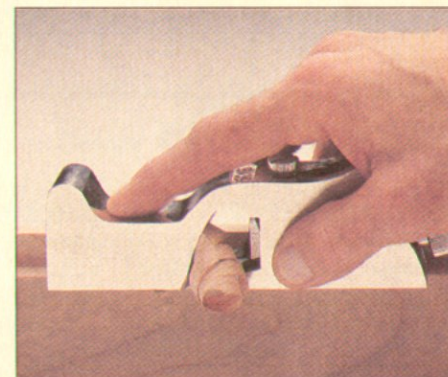

Shoulder Planes

page 22

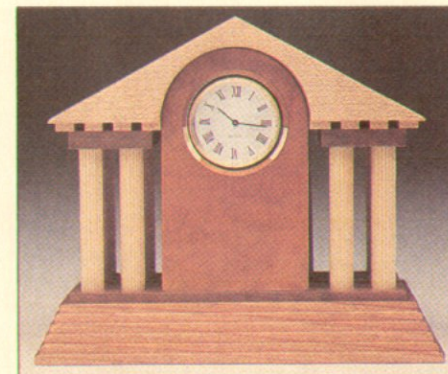

Desk Clock

page 28

Tips & Techniques

TABLE SAW JOINTING

■ Because I don't have a jointer, I could never cut a perfect edge on boards when edge-gluing panels — until I came up with a solution using my table saw and a sharp saw blade.

I rip the mating edges of the boards at the same time using the table saw, see Fig. 1. This

way, if the saw blade is not set exactly at 90°, any deviation will be split between the two edges.

To do this, first rough-cut the pieces to within 1/8" of final width, but cut the lengths oversized. Then place the boards edge-to-edge as you want them to be arranged in the panel.

Next, tack a cleat to the ends of each board so that they're held together tightly, see Fig. 1a. (If the wood is smooth, you could use double-sided carpet tape instead of the nails.)

Then, with the blade just high enough to cut into the cleat, saw right through the joint, see Fig.

1b. Ripping the two edges together ensures that both edges will match up perfectly.

Finally, remove the cleats and glue up the boards. Then, after the glue is dry, cut the panel to length to remove the nail holes.

*Gaylord Anderson
Carbondale, Kansas*

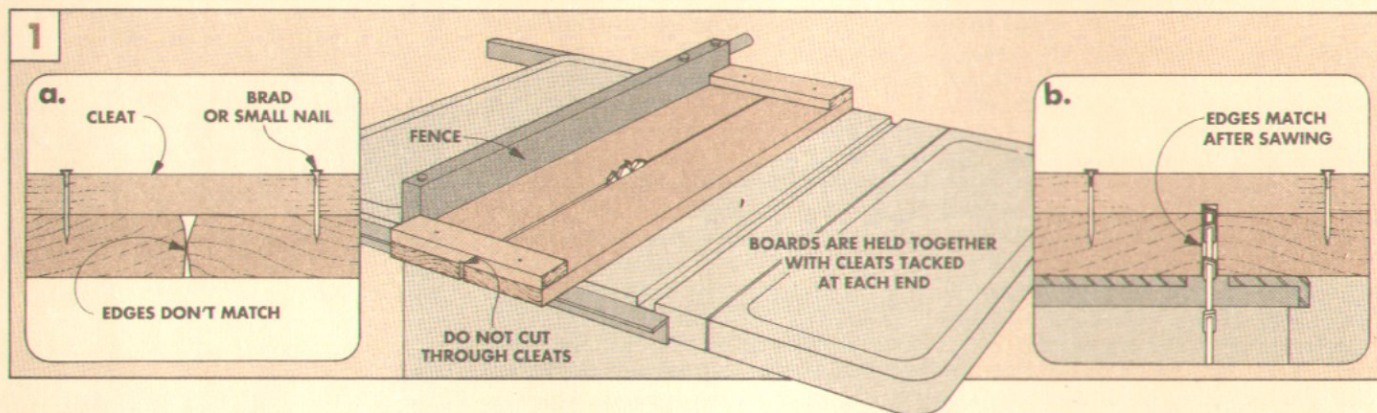

CROSSCUT JIG

■ The ripping jig shown in *Woodsmith* No. 70 came in handy when I was ripping some crooked walnut recently. But I also needed an accurate way to cross-cut some of the longer pieces. (I don't have a radial arm saw.) To solve this, I used some of the ideas from the ripping jig to make a crosscutting jig.

The crosscutting jig has three parts, a 3/4"-thick plywood sled, a plywood fence, and a hardwood runner, see Fig. 1. To hold longer pieces of stock on the jig, I used two of the hold-downs that were featured in *Woodsmith* No. 70, see Fig. 1a. But toggle clamps would work just as well, see Fig. 1b.

I made the sled deep enough to handle a 12"-wide board, see Fig. 1. And the length of the sled is long enough to support long workpieces, but the overall dimensions ensure that most of the sled's weight remains securely on the saw table.

The 4 1/2"-wide fence is cut to the same length as the sled. I cut

the fence wide enough to accommodate the heel on the hold-down clamps.

Now, instead of wrestling with a long board against a miter gauge, I can push the sled and the workpiece through the saw blade together.

*Barnett C. Howard
Sisters, Oregon*

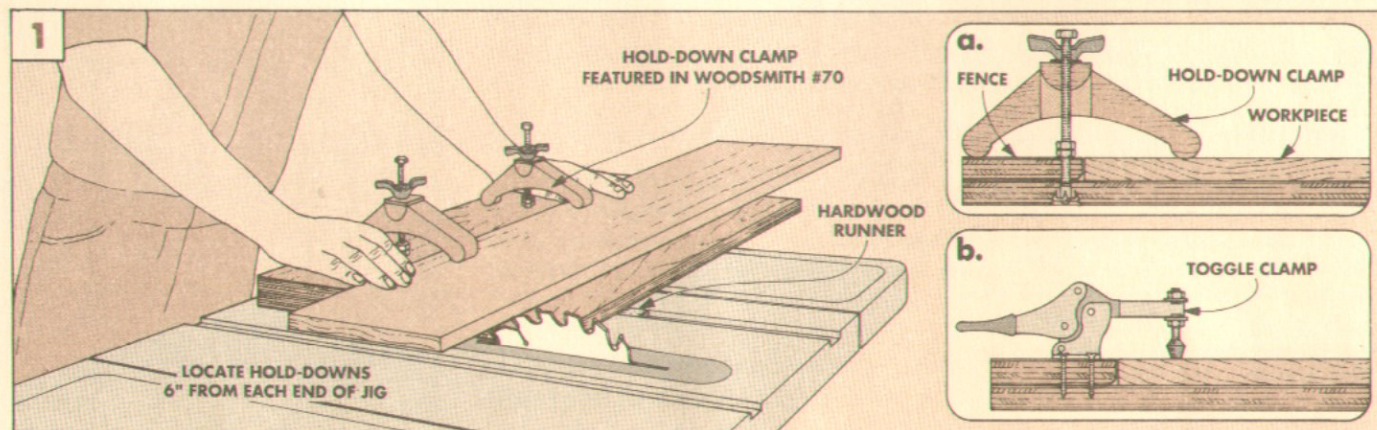

PUTTY KNIFE SCRAPER

■ I prefer to finish my wood-working projects with a cabinet scraper rather than sandpaper. But a cabinet scraper can be tiring to hold, especially when working on a large project. To get around this problem, I made a cabinet scraper from a putty knife, see Fig. 1.

The large handle of the putty knife makes it less tiring to hold the scraper and easier to control.

The only trick to using a putty knife as a scraper is to buy one with a heavy duty blade that doesn't flex much. I sharpen the edge at 45° and then turn over (burnish) a cutting edge, see Fig. 1a.

The result I get with a putty knife scraper is just as good as I get with a traditional scraper.

Joseph W. Gibson IV
Gaithersburg, Maryland

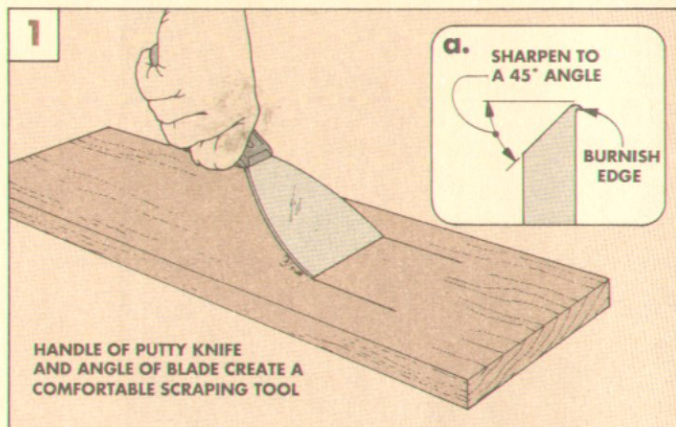

GRINDING STOP GAUGE

■ I always had trouble maintaining the proper pressure against the grinding wheel while grinding chisels. And each time I removed the chisel to dip it in water and then back to the grinder, I had trouble gauging where I left off grinding. But I discovered a trick that helps—I use a stop that positions the cutting edge against the wheel each time, see Fig. 1.

After the tool rest is set to the correct grinding angle, clamp a small C-clamp to the chisel shaft, see Fig. 1a.

The C-clamp eliminates having to gauge the correct pressure each time the chisel is placed on the wheel. All I do now is push the C-clamp up against the tool rest and lower the chisel.

Robin Coggeshall
Fowler, Illinois

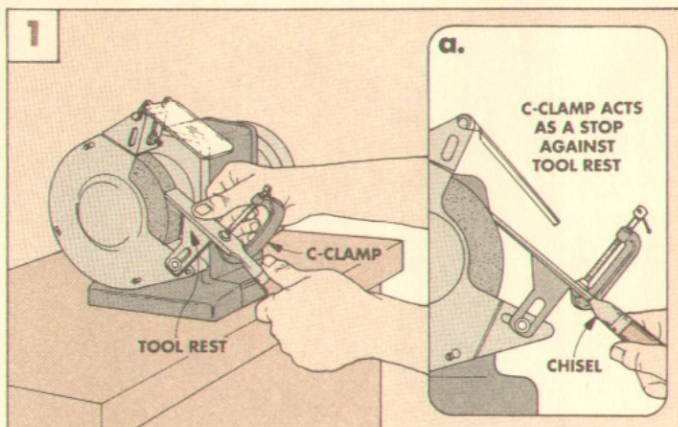

QUICK TIPS

FLATTENING STONES

■ For years I've used waterstones to hone my chisels. But the more I used them, the more they became "dished" down the center. Finally, the waterstones became useless. Rather than throw them out, I came up with an easy way to flatten them so they can be reused.

To do this, I use my concrete garage floor, but any flat concrete surface would work.

I discovered that if I place a small amount of fine sand on the floor, and then gently rub the stone back and forth over the sand, it can be quickly ground flat once again.

Lester Babcock
Rockford, Michigan

MIXING CONTAINERS

■ Recently I needed to mix up a small amount of epoxy glue. While I was searching for something to mix it in, I found an old plastic ice cube tray that my wife was about to throw away.

The individual cubicles in the tray are just the right size for mixing small amounts of epoxy. When I'm finished with the epoxy, I just cut off the used cubicle and throw it away.

Also, when doweling or gluing small pieces, it's easiest to pour some glue in a cubicle and dip the piece in the glue. Yellow and white glue can be washed out and the cubicle reused.

William Habjan
Lebanon, Oregon

SCROLL SAW TIPS

■ Recently, two readers wrote and told us how they've made it more enjoyable to use their scroll saws. **Wayne Dragish** of Linwood, Pennsylvania places a router pad under his scroll saw to help cut down on the noise and vibration. These pads are sold at woodworking retail stores and through most woodworking mail order catalogs.

The pad also saves him time. Instead of clamping the scroll saw down to the workbench, he just places it on top of the pad. The pad keeps the saw from moving around the workbench.

Ted Routson of Milwaukie, Oregon shared with us a tip he discovered when the diaphragm that pumps air across his scroll saw table stopped working.

Instead of tearing his saw apart to get at the old diaphragm, he attached an aquarium pump to the original air hose. It clears away just enough sawdust from the blade to provide a clear view of the cut line—an area about 1" in diameter.

SEND IN YOUR TIPS

If you would like to share a tip or idea, just send it to *Woodsmith*, Tips and Techniques, 2200 Grand Ave., Des Moines, Iowa 50312.

We will pay upon publication \$15 to \$100 (depending on the published length of the tip). Please include an explanation and a sketch or photo (we'll draw a new one).

Pedestal Desk

The symmetry of this desk makes the building process straight-forward — the pedestals are identical and so are the drawers. And an optional file drawer and vanity panel let you fit the desk to your needs.

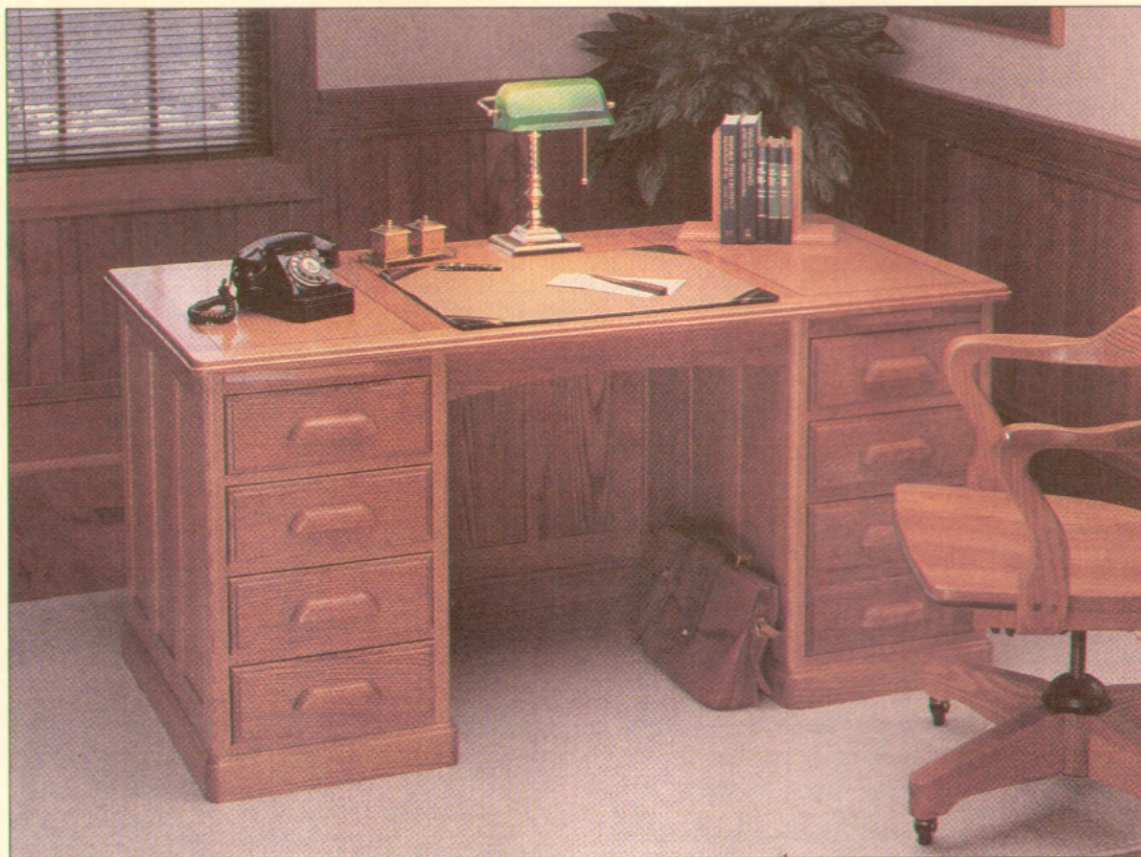

I had already built this Pedestal Desk from working drawings, when Rod, our assistant art director, showed me the Exploded View (on the opposite page). That's when I got worried. The Exploded View looks complicated — even more complicated than the desk I'd just built.

But then I realized one of the great things about a pedestal desk is its symmetry. The pedestals are identical, the panels are identical, even the drawers are the same. So building a pedestal desk requires a lot of repetitive cuts.

It's not basic construction that inspired me to make this Pedestal Desk, it's the classic design. This desk looks like a pedestal desk of a hundred years ago. But some of the joinery techniques and materials are new.

JOINERY AND WOOD. For example, I used stub tenon and groove joinery to make the side and back frames. It

looks like the frame and panel joinery of a hundred years ago. And the oak veneer plywood for the panels wasn't around that long ago either. But in combination with the solid oak base and frames, it has the traditional look, with greater dimensional stability.

OPTIONS. One of the things you're as likely to need today as a century ago is a file drawer. So we show how to make this desk with one (or as many as four).

Another option is a vanity panel, see photo on page 32. It encloses the knee space between the pedestals on the back of the desk. While it may keep others from seeing your scuffed-up shoes, it's probably better for keeping your legs warm in a drafty room. In any case, the vanity panel also makes the desk seem larger and more formal.

MATERIALS LIST. The Materials List and Cutting Diagram are on page 15. And sources for all the hardware are listed on page 31.

EXPLODED VIEW

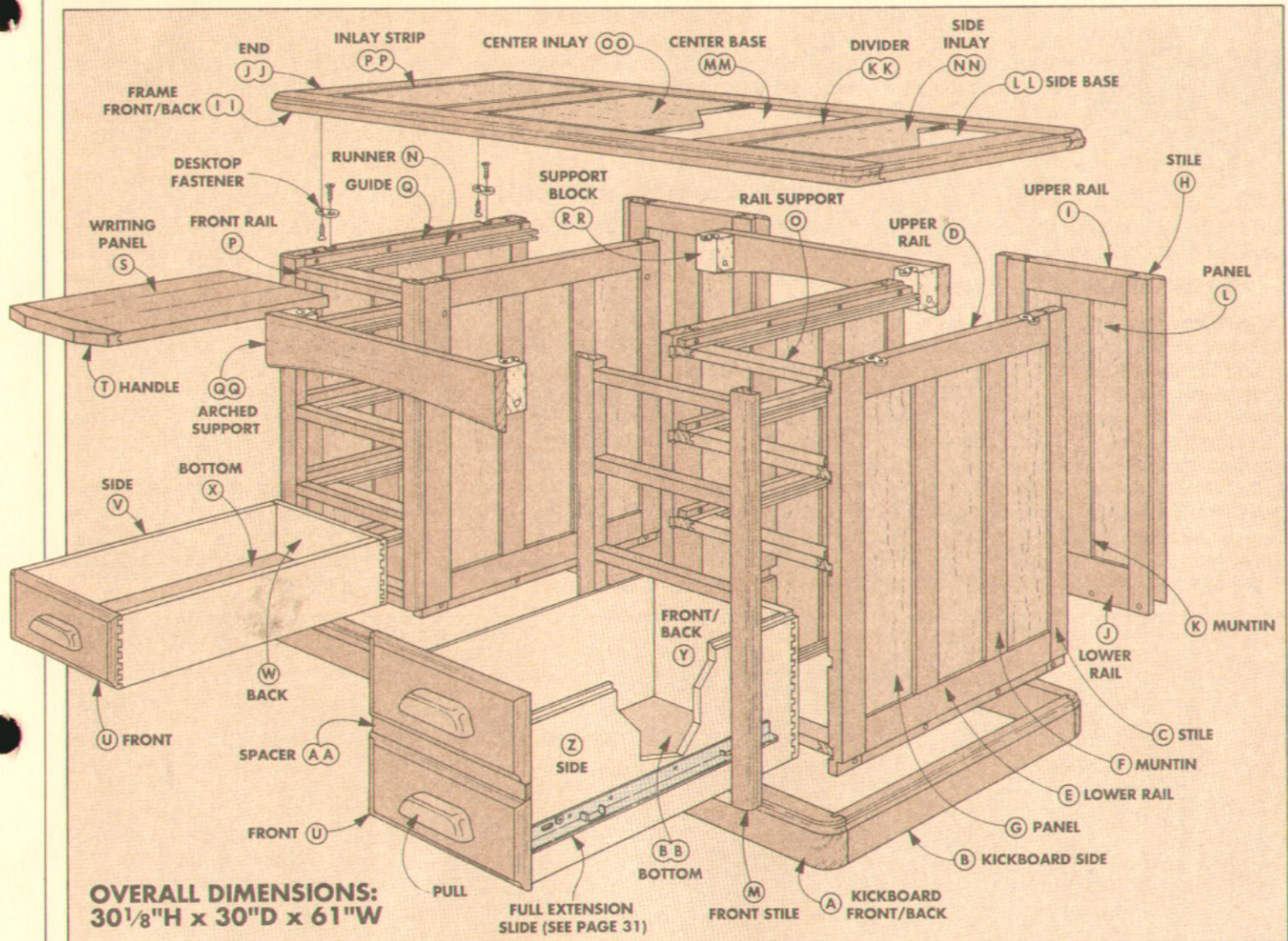

PEDESTAL BASES

I began work on the desk by making the bases for the pedestals. Each base is made up of four pieces — 1"-thick kickboard fronts/back (A) and 3/4"-thick kickboard sides (B), see Fig. 1. (Since the desk has two pedestals, make four of each piece.)

DADOES. The base pieces are joined with tongue and dado joints. The dados are actually saw kerfs cut across the inside face of the kickboard fronts and backs (A). To do this, adjust the rip fence on the table saw so the distance from the outside of the blade to the fence equals the thickness of the side pieces (3/4"). Now set the blade to cut 1/8" deep, and cut the dados using the fence as a stop.

CUTTONGUES. After the kerfs are cut in the front/back pieces (A), cut matching tongues on the ends of all the side pieces (B), see Fig. 1a. Once the tongues are cut, the bases can be glued together, see Fig. 1.

ROUND CORNERS. A typical design feature on a desk like this is large rounded corners.

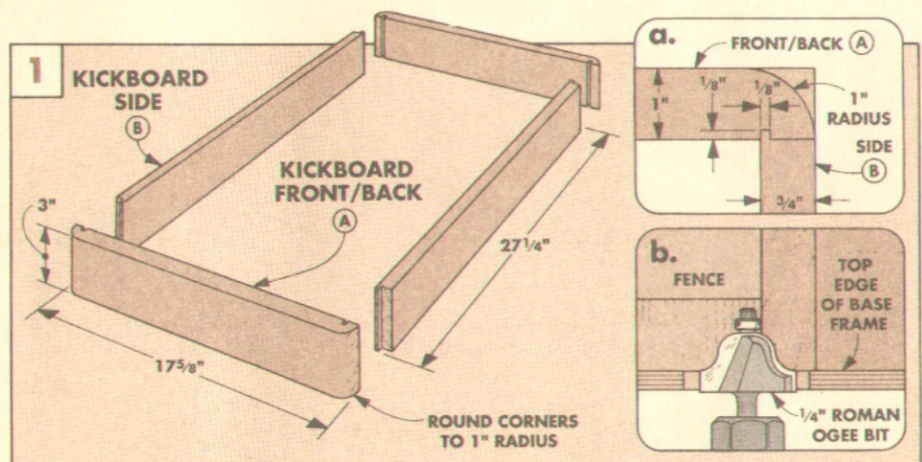

To round the corners, start by drawing a 1" radius arc on the corners, see Fig. 1a. Then rough cut the corners on the band saw and sand them smooth.

ROUT OGEE. The last step in making the

bases is to rout an ogee on the top edges, see Fig. 1b. To do this, mount a 1/4" Roman ogee bit in the router table. Then with the top edge of the base frame down on the router table, rout the ogee on the outside edges of all four sides.

PEDESTAL SIDES AND BACKS

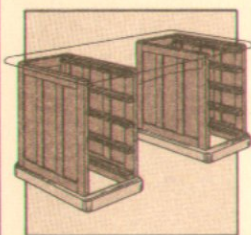

Once the pedestal bases are complete, the next step is to make the frame and panel units for the pedestal sides and back. This is a systematic process — each of the side and

back panel units is made the same way, in a series of repetitive steps.

RAILS, STILES & MUNTINS

Begin the process by cutting eight pieces of $\frac{3}{4}$ " stock for the *side upper rails (D)* and *lower rails (E)* to length, see Fig. 2. Then cut the four pieces for the *back upper (I)* and *lower rails (J)* to length.

The twelve *stiles (C, H)* for all the frames are the same length ($27\frac{1}{8}$ "), see Fig. 2. Each of the frames is divided by one or two vertical *muntins (F, K)*. And all of these muntins are also the same length ($21\frac{5}{8}$ "), see Fig. 2. So cut all the muntins to this length.

RIP TO WIDTH. With all the pedestal frame

pieces cut to finished length, the next step is to rip the pieces to finished width. All the upper rails, muntins, and back panel stiles are ripped to the same width ($2\frac{1}{2}$ "), see Fig. 2. The side panel stiles are ripped a little narrower (2 "). And, finally, the lower rails are ripped wider ($3\frac{1}{2}$ ").

GROOVES AND STUB TENONS

After all the frame pieces have been cut to finished size, they can be joined together with stub tenon and groove joints. (For a detailed explanation of stub tenon and groove joinery, see *Woodsmith* No. 74.)

CUTTING THE GROOVES. To begin the joinery, first cut a $\frac{1}{4}$ "-deep groove on the inside edge of all of the stiles and rails, and on both edges of the muntins, see Figs. 2a, 2b, and 2c.

Center the grooves on the thickness of the workpiece, and cut the grooves the same width as the thickness of the plywood that will be used for the panels ($\frac{1}{4}$ " plywood is usually less than $\frac{1}{4}$ " thick).

STUB TENONS. All the stub tenons are cut the same way and at the same time. I used

the table saw with the rip fence positioned $\frac{1}{4}$ " from the outside of the blade. To determine the height of the blade, I used a test piece the same thickness as the actual workpieces. Sneak up on the height, cutting on both sides of the test piece until the tenon just fits the grooves.

Once the tenon on the test piece fits, tenons can be cut on the ends of the muntins (see Fig. 2b) and the rails (see Fig. 2c).

PLYWOOD PANELS. After the stub tenons and grooves have been cut on the frame pieces, the next step is to cut the $\frac{1}{4}$ " plywood panels (*G* and *L*) that fit inside the frames. The plywood panels are all cut the same length as the muntins. To determine the width of all the panels, I dry assembled a side frame and back frame, see Fig. 2. Then measure the distance from groove to groove and cut the plywood panels to fit.

ASSEMBLY. With the plywood panels cut to size, the frame and panel units can be assembled. Make sure the four side units are identical in size, and that the two back units are identical as well.

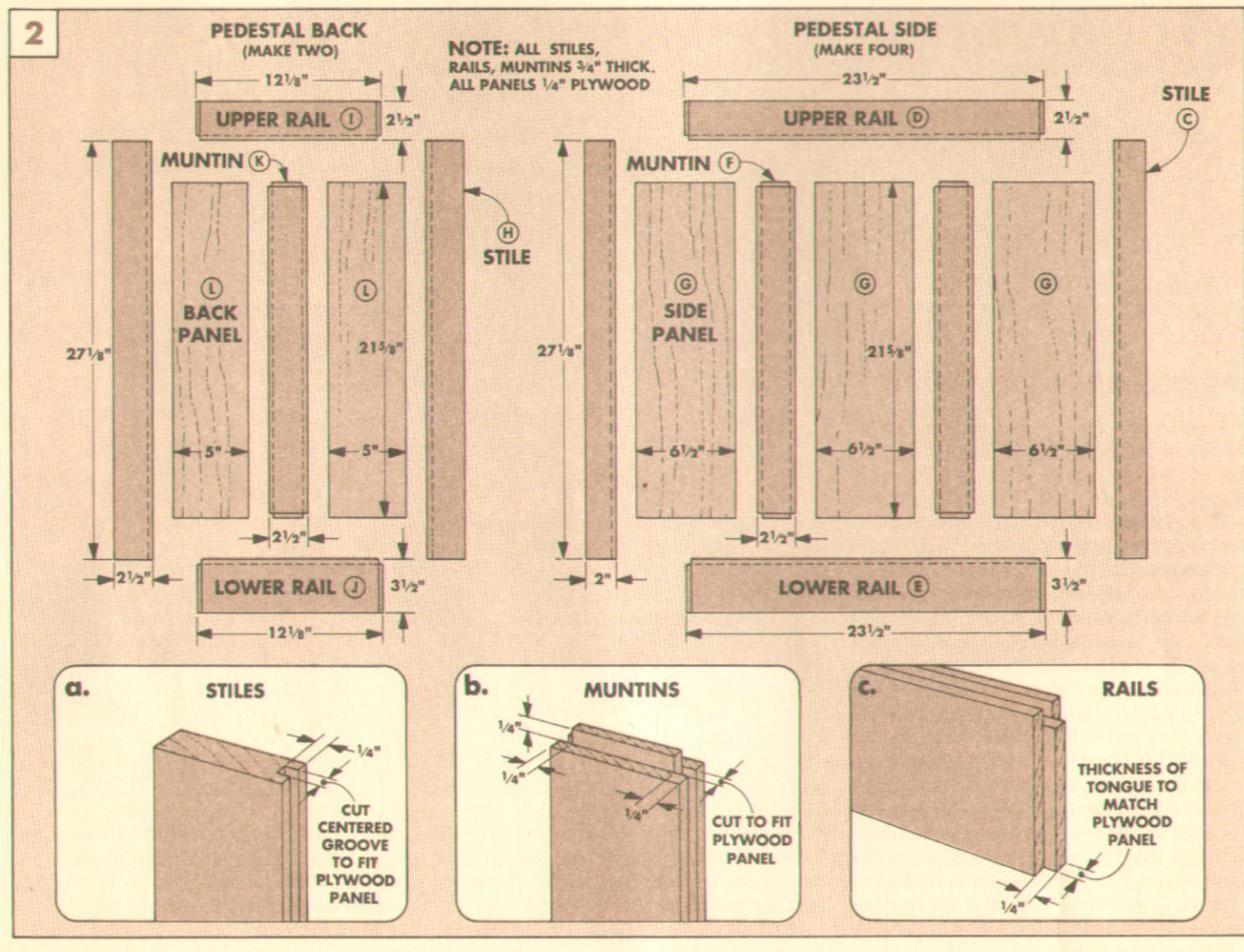

CONTINUED

At this point the major components of the desk, the base and panel units, are complete. But before these units can be assembled into the pedestals, joints need to be cut on each unit so they fit together and onto the base.

RABBETS. The side and back units fit inside the top of the pedestal base by means of a rabbet at the bottom of the units, refer to Figs. 3a and 3c, and Fig. 6 (on the next page). A rabbet joint is also used to join the sides to the backs, see Fig. 3b.

To cut the rabbets, I used a dado blade on the table saw. (Note: To avoid chipout, I first cut the shoulders with a crosscut blade.) Start by cutting the rabbets on the *lower outside* edge of each unit, see Fig. 3a and 3c. Then move the rip fence and cut a rabbet on the inside face of the *back* stiles, see Fig. 3b.

ROUND-OVERS. To complete the work on the back units, rout a 1/2" round-over on the *outside* edge of the back stiles, see Fig. 3b. Then the back units can be set aside until it's time for assembly.

DADOES. When the rabbets and round-overs are complete, dados can be cut on the *inside* of the sides for the drawer runners. To cut these, first set up a 3/4"-wide dado blade to cut 1/8" deep. Then lay out the dados on one of the side units, see Fig. 3d.

Now cut the matching dado on each of the four side units before moving the rip fence to cut the next set of dados. This way, all facing dados for the runners will be aligned.

RUNNERS. Next I made the 18 **drawer runners (N)** to fit into the dados. (Why 18 runners? I built the desk with six standard drawers requiring two runners each. Plus a file drawer that required two runners, and four more runners for the writing slides.)

The runners are made from 3/4"-thick stock ripped to a width of 1 1/8", see Fig. 4a. Cut the runners 5/8" shorter than the width of the side units. This way, they won't interfere with the back units when you're assembling the pedestals.

Before gluing the runners into the dados, cut a 1/4"-deep groove in each runner for attaching rail supports, refer to Fig. 7 (on the next page). Center this groove on the thickness of the runner, see Fig. 4a.

Now the runners can be glued into the dados. Set the runners back 1/4" from the front edge to leave room for front stiles that are added later, see Fig. 4.

DRAWER GUIDES. There's just one more step before the pedestals can be assembled — cutting and installing **drawer guides (Q)**, see Fig. 5. The guides serve as spacers in the completed desk to keep the drawers tracking straight in and out of the pedestals.

When the guides have been cut to finished size, screw them to the side units on top of the drawer runners, see Fig. 5a. Note: Don't glue the guides in place. This way they can be removed and custom fit (if necessary) when the drawers are installed.

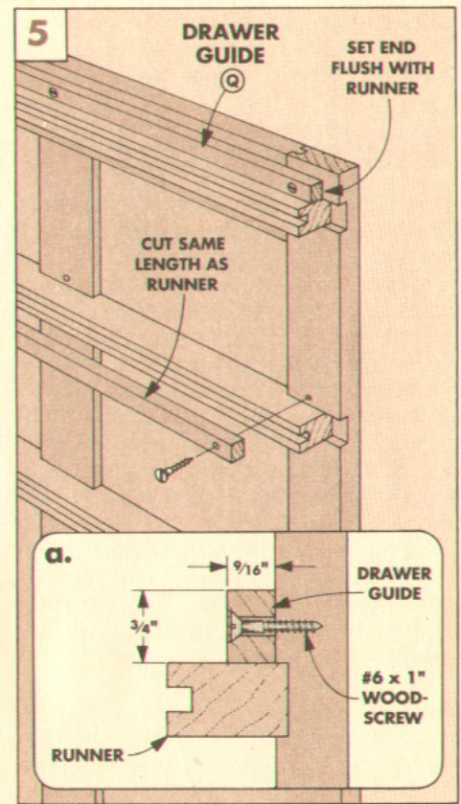
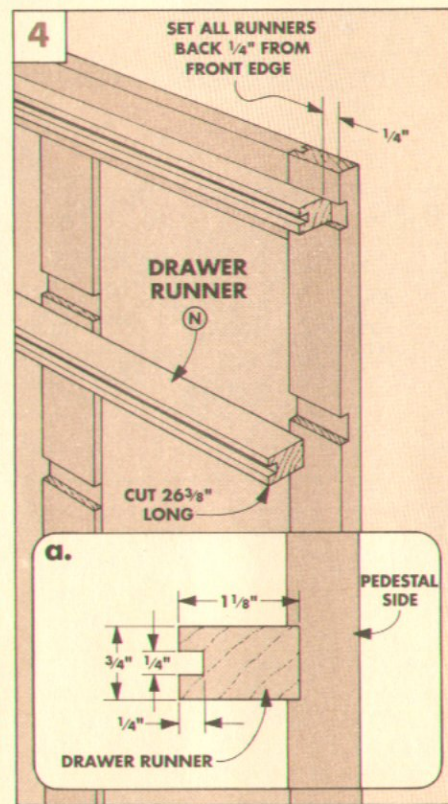
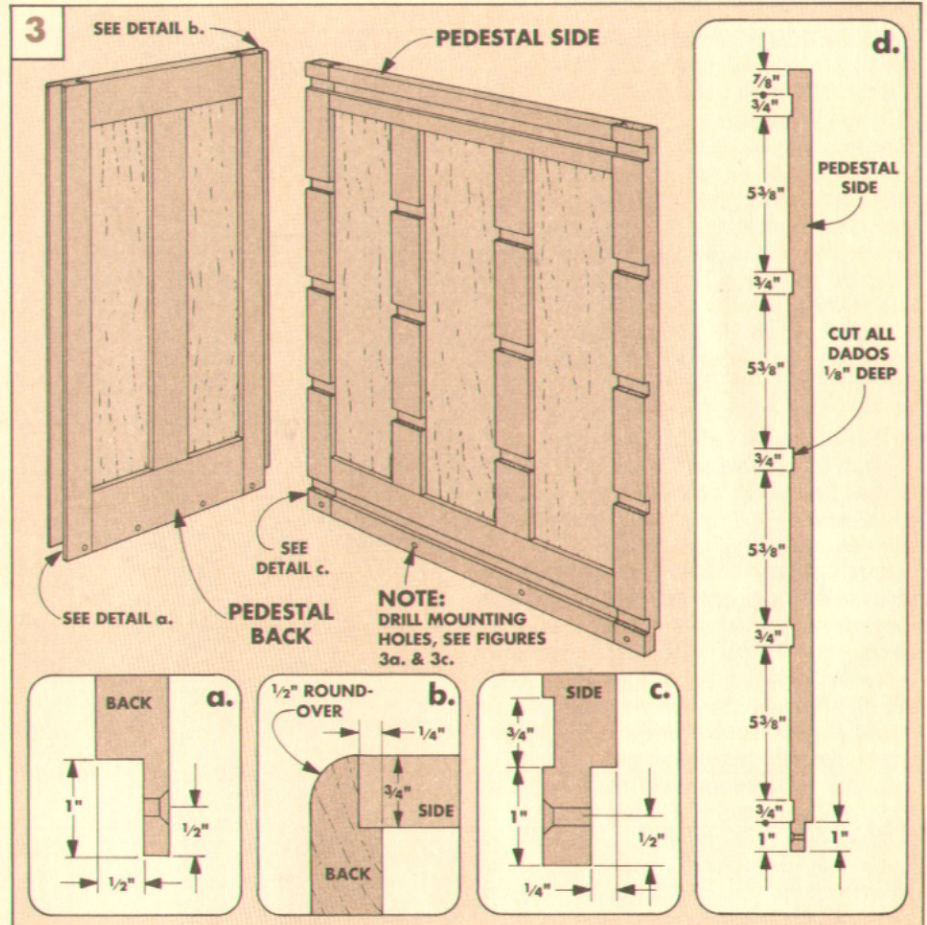

PEDESTAL ASSEMBLY

Once the drawer runners and guides are in place, the pedestals can be assembled.

ATTACH SIDES & BACK. First, position each side unit in the base and then screw it to the base from the inside, see Fig. 6b.

Then, the backs can be installed. To do this, first spread glue along the rabbets in the stiles. Then slip the bottom rabbet over the top edge of the base, and clamp the back between the sides. Now drive the screws into the base through the rabbet.

FRONT STILES. The front edges of each pedestal are covered with **front stiles (M)**, see Fig. 6. Cut four of these to a width of $1\frac{1}{4}$ " from $\frac{3}{4}$ " stock. Then cut them to length so they match the height of the sides.

Next, cut a rabbet on the back side of each stile and rout a $\frac{1}{2}$ " round-over on the front edge, see Fig. 6a. Now glue the front stiles to the side units, see Fig. 6.

RAIL SUPPORTS. The desk drawers are separated by supports that stretch between the front stiles. Each support consists of two pieces, a rail support that fits in the grooves between the drawer runners, and a front rail, see Figs. 7 and 8. Note: If you plan to build the file drawer (see box on facing page), you need only make nine supports.

Cut the **rail supports (O)** to a length that matches the distance between the grooves in the drawer runners. Next, cut a centered tenon on each end of the supports to fit the grooves in the runners. Then glue the supports into the grooves on the runners.

FRONT RAILS. Now cut the **front rails (P)** to length so they fit between the front stiles. Then glue and clamp the rails in place to the front edge of the rail supports, see Fig. 8.

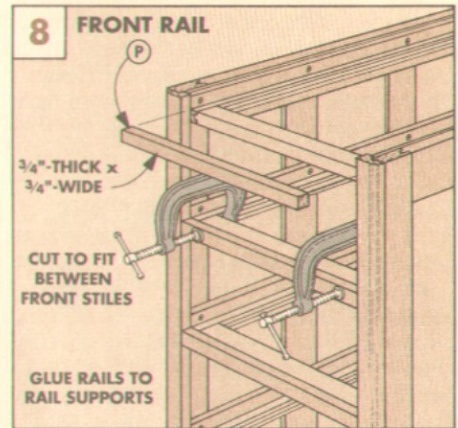
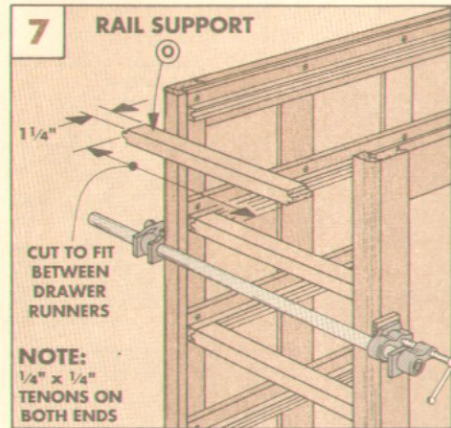
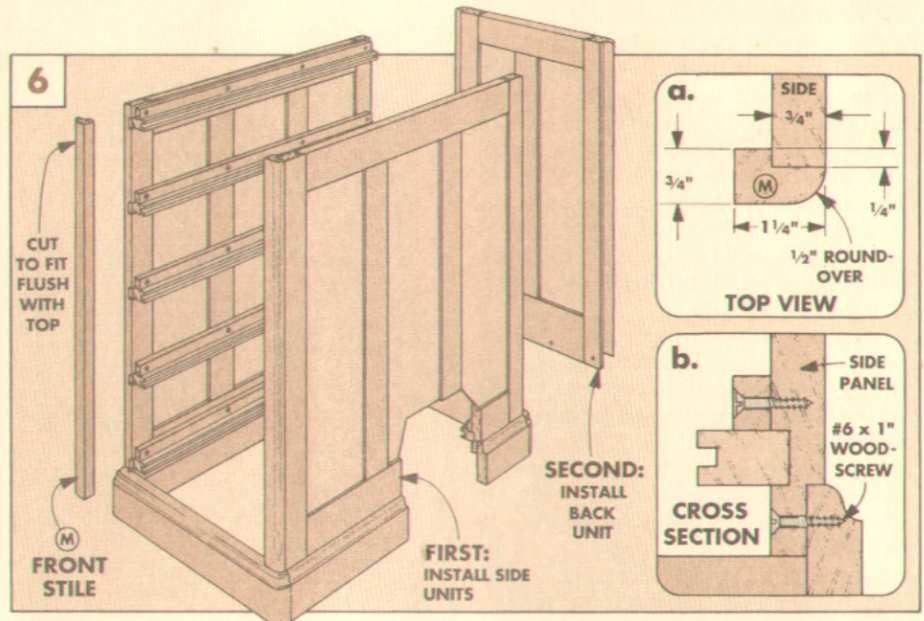

WRITING SLIDES

One of the traditional features of a pedestal desk is a writing surface or slide that pulls out from the top of each pedestal.

SLIDES. To build the slides, first glue up stock for two **panels (S)**. Then, trim them to length ($26\frac{1}{4}$ ") and $\frac{1}{8}$ " narrower than the opening in the pedestal, see Fig. 9. Now, cut a tongue along the front edge, see Fig. 10.

HANDLES. Next cut a pair of **handle (T)** blanks to finished dimensions, see Detail in Fig. 9. Then cut a groove along the inside edge of the handles to accept the tongue on the panels, see Fig. 10.

To rout a finger slot on the bottom side of the handles, I used a $\frac{1}{2}$ " core box bit mounted in the router table. Then, taper the front corners of each handle, and glue the handles onto the panels, see Fig. 9.

POSITIONING THE SLIDES. Each slide should be positioned in its pedestal so the the handle extends $\frac{3}{4}$ " beyond the front stiles, see Fig. 11. To do this, measure the depth of the opening and cut the slides to fit.

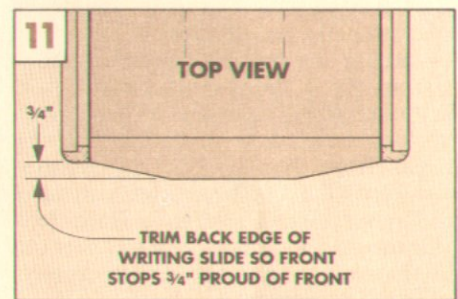
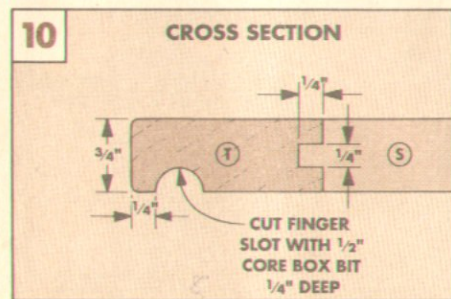
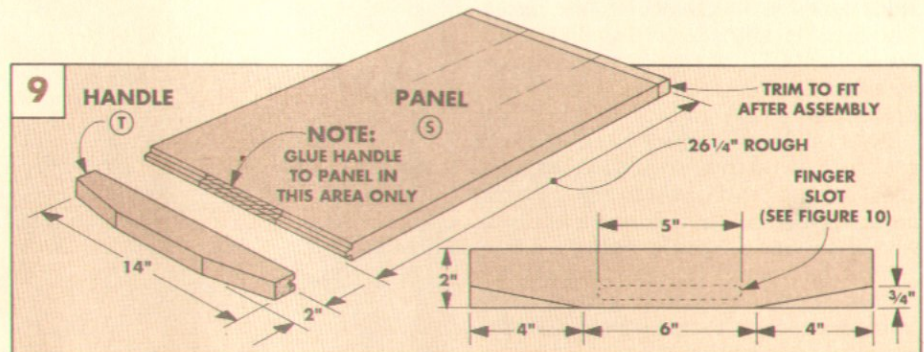

DRAWERS

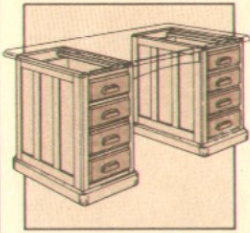

The drawers are built from 1/2"-thick sides and backs and 3/4"-thick fronts.

DRAWER PARTS.

Each drawer is designed to fit in its opening with a 1/16" gap all around. So, measure the openings and cut the **fronts (U)** and **backs (W)** 1/8" less than these dimensions. Next cut the **sides (V)** 23 5/8".

FRONT OGEE. Now, rout an ogee on the face of the drawer fronts. To do this, I used the same bit as on the base. But, I set the fence on the router table to decrease the width of the cut from 1/2" to 3/8", see Fig. 12a.

DRAWER JOINTS. I used half-blind dovetail joints to join the drawer sides to the fronts and backs. (For information on a jig and more about dovetails, see page 31.)

DRAWER BOTTOMS. Now, cut a groove for the bottom through the lowest dovetail slot, see Fig. 12b. Then, after cutting a bottom to fit, glue each drawer together.

PULLS. The last step is to screw pulls to the front of each drawer. For information on making your own pulls, see page 17.

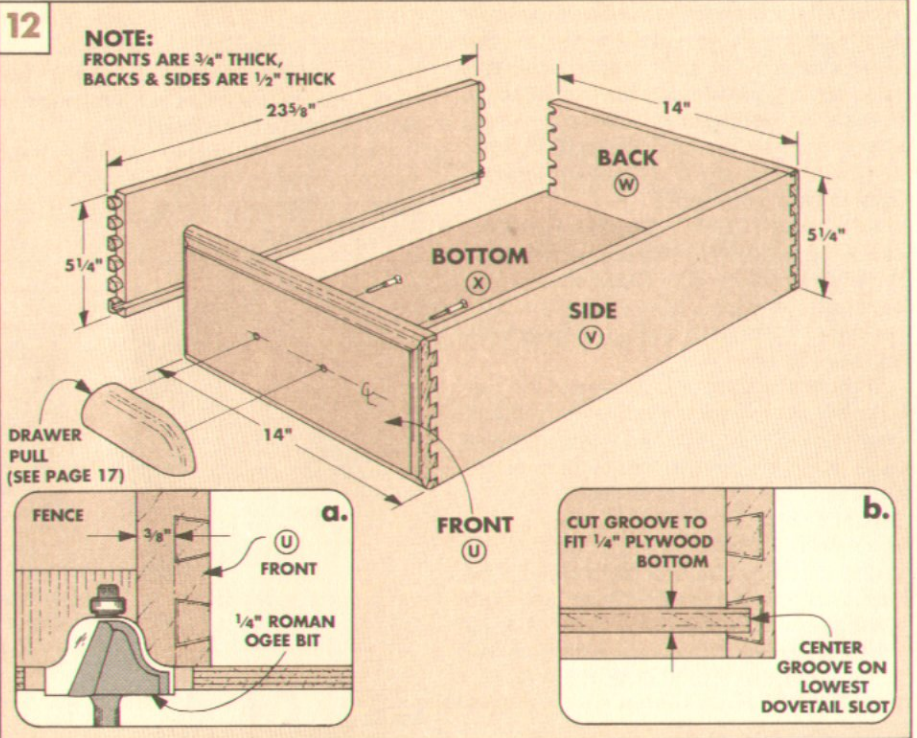

FILE DRAWER



One of the neat things about this file drawer is that, from the front, it doesn't look like a file drawer — it looks like two regular drawers. To achieve this, the file drawer is built differently than the others.

FALSE FRONT. The first difference is that the file drawer is made from 1/2"-thick stock with a 3/4"-thick false front attached to it. The false front is made of two regular **drawer fronts (U)** plus a **spacer (AA)**, see Fig. 2.

NARROWER DRAWER. The file drawer is narrower than the other drawers, see Fig. 1. There are two reasons for this. First, the file drawer holds hanging file folders that hang on the top edge of the drawer without any hardware, see Fig. 1a. Also, the narrower drawer allows clearance for the full extension slides to be mounted between the

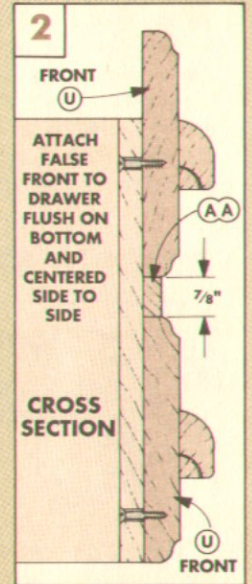
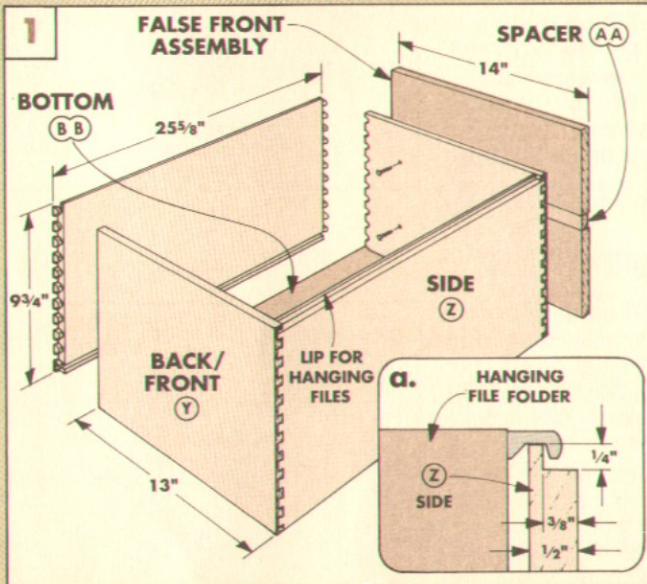

drawer sides and the sides of the pedestals.

MAKING THE DRAWER. To make the file drawer, first build a dovetail box to fit the large drawer opening, see Fig. 1. I used poplar for the **front, back, and sides (Y)(Z)**, and 1/4" plywood for the **bottom (BB)**. Note: Before assembling the box, cut 1/4" deep rabbets on the top edge of the drawer sides for

the hanging file folders, see Fig. 1a.

Next, cut a 3/8"-thick spacer (AA) 7/8" wide and glue this between two drawer fronts (U), see Fig. 2. Then attach the false front to the drawer, and then install the drawer in the pedestal with the extension slides.

Full extension slides are available from *Woodsmith Project Supplies*, page 31.

FITTING DRAWERS

When all the drawers are built, you'll probably want to test them in the pedestals. But don't expect them to fit properly the first time. Several adjustments have to be made. In order for the drawers to slide easily — and also look good — they have to fit in three directions — side to side, top to bottom, and front to back, see Fig. 13.

SIDE TO SIDE. To fit a drawer side to side, check the gap between the drawer sides and the drawer guides (Q). There should be a slight gap on each side — enough to allow the drawer to move in and out without binding, see Fig. 14.

If there's no gap, or if the gap is too narrow, the guides need to be removed and planed to fit. If you do plane the guides, plane each guide an equal amount. Then screw them back in and test the fit again.

TOP TO BOTTOM. Now check the distance above each drawer front when the drawer is in the closed position. It will probably be about $\frac{1}{8}$ ". To create a uniform $\frac{1}{16}$ " gap above and below the drawer front, I stuck self-adhesive nylon glide strips to the top of the runners, see Fig. 13. The strips do two things: they even out the gap, and they make the drawers slide easily.

FRONT TO BACK. When the drawer is closed, the drawer front should stick out $\frac{3}{8}$ " from the face frame, see Fig. 14. This means you can see the entire molded edge of the drawer front, but the dovetails aren't visible. To prevent the drawer from sliding in further, I glued a small **stop block (R)** onto the runner behind the drawer, see Fig. 15.

INSTALLING THE STOP BLOCK. To make it easier to position the drawer while installing the stop block, I made a simple L-shaped gauge, see box above.

DRAWER GAUGE

To help position the drawers in the pedestals, I made a special gauge. The gauge is just a piece of $\frac{3}{4}$ "-thick scrap cut to an "L" shape. The "foot" of the gauge extends $\frac{3}{8}$ " beyond the "body."

To position the drawer, hold the foot of the gauge against the face frame while holding the body of the gauge against the drawer front, see photo.

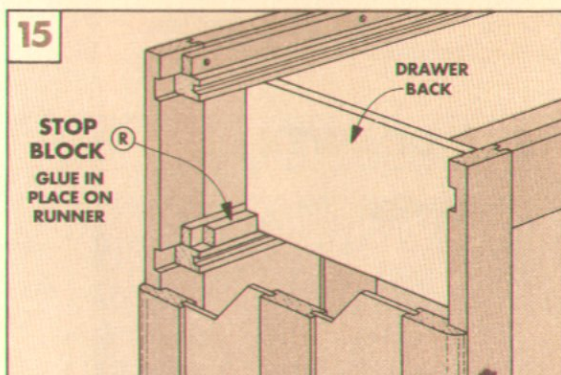
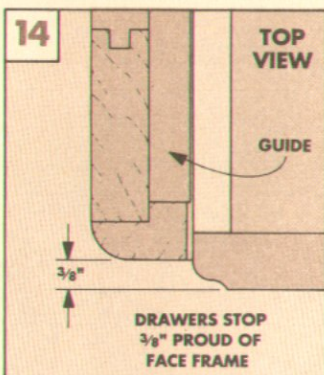
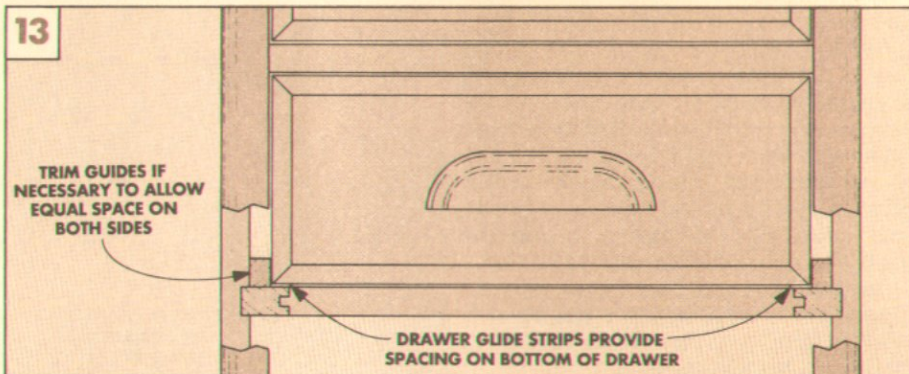

ARCHED SUPPORTS

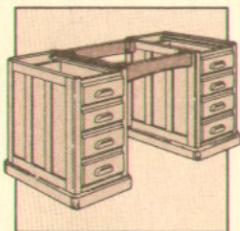

When the drawers have been fitted in the pedestals, the pedestals can be joined. This is done by a pair of arched supports that bridge the opening between the pedestals.

Note: If you make the optional vanity panel, you'll only need to make one support.

CUTTING THE ARCH. Begin making the **arched supports (QQ)** by first cutting two pieces of $\frac{3}{4}$ " stock to finished width and length, see Fig. 16. Then comes the tricky part — laying out the curve of the arch. To do this, first mark the high point of the curve (1" up from the bottom edge) centered across the back of the workpiece. Then drive a finishing nail into each of the bottom corners, about $\frac{1}{8}$ " above the bottom edge.

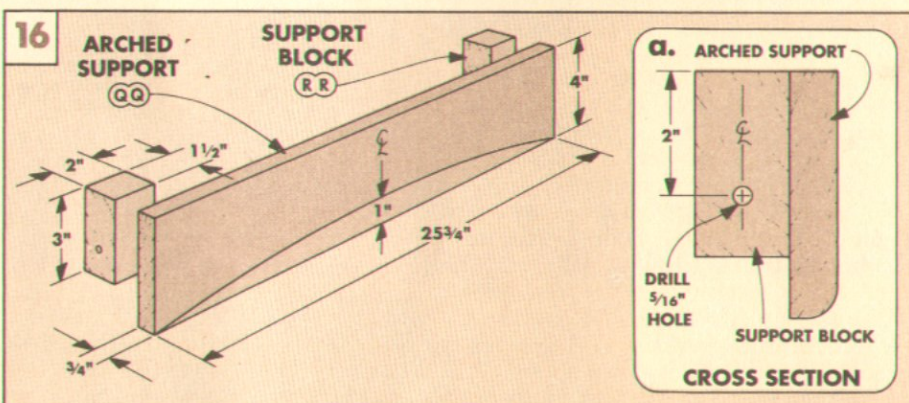

Next, spring a flexible wood strip (like a yard stick) between the two nails until it reaches the high point of the curve. Now, draw this curve on the workpiece.

SUPPORT BLOCKS. To attach the supports

to the pedestals, I added **blocks (RR)** to the back face, see Fig. 16. After cutting these, bore a $\frac{5}{16}$ "-diameter hole through each block to accept a carriage bolt, see Fig. 16a. Then glue the blocks to the supports.

JOINING THE PEDESTALS

Before installing the arched supports between the pedestals, you'll need to drill $\frac{5}{16}$ "-diameter holes in the sides for the carriage bolts, see Fig. 17. To locate these holes so they align with the holes in the support blocks, I temporarily clamped the pedestals together with the arched supports in place.

Note: The top edge of the supports should be flush with the top of the pedestals. But the supports should be set in 1" from the front (or back) of the pedestals, see Fig. 17a.

Now drill holes in the side panel using the holes in the blocks as a guide. When the holes are drilled, bolt the pedestals together.

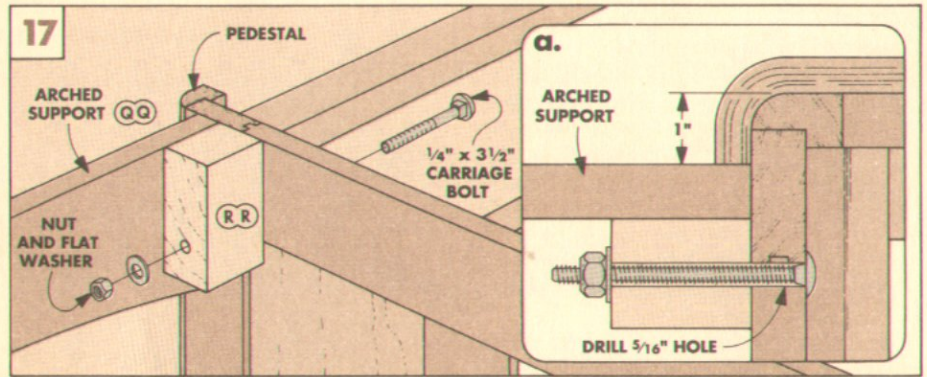

OPTIONAL VANITY PANEL

A vanity panel between the pedestals encloses the knee hole at the back of the desk.

To build the vanity panel, I used frame and panel joinery with stub tenons and grooves. It's made the same way as the pedestal sides, with a couple differences, see Fig. 1.

LOWER RAIL. First, the lower rail (EE) is wider than the lower rails in the pedestals. This provides more surface for attaching

the kickboards, see Fig. 2.

NOTCHES. The second difference is a couple of notches. Once the panel is built, notches on the bottom corners reduce the panel's width so it fits between the pedestal bases, see Fig. 1a.

When you're done building the vanity panel, cut the notches $\frac{1}{2}$ " wide and 3" high.

KICKBOARDS. A pair of kickboards hide the notches on the outside and inside of the panel,

see Fig. 2. To make the kickboards (HH), first cut a pair of blanks so they're an inch or two longer than the width of the vanity panel ($25\frac{3}{4}$ "), see Fig. 1.

Then cope the ends to match the shape of the pedestal kickboards. (For information on how to cope molding, see page 16.)

Finally, glue the kickboards to the vanity panel.

INSTALLATION. I used machine screws and threaded in-

serts to install the panel between the pedestals, see Fig. 3a. To do this, first drill holes through the pedestal sides for the screws.

Next, temporarily clamp the panel in place between the pedestals. Then, using the holes in the side panels as a guide, mark the locations for the threaded inserts on the edges of the vanity panel. Finally, install the threaded inserts and screw the panel in place.

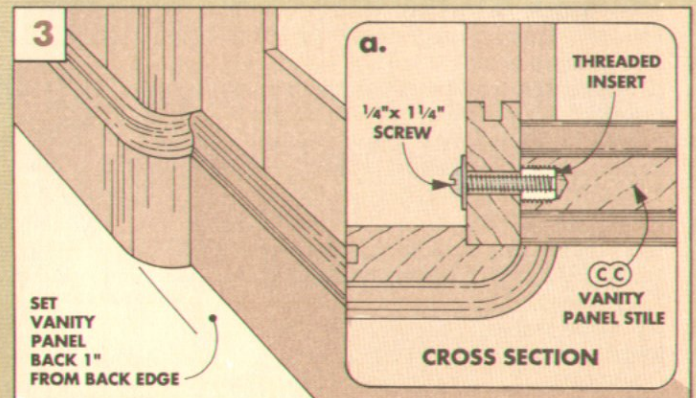
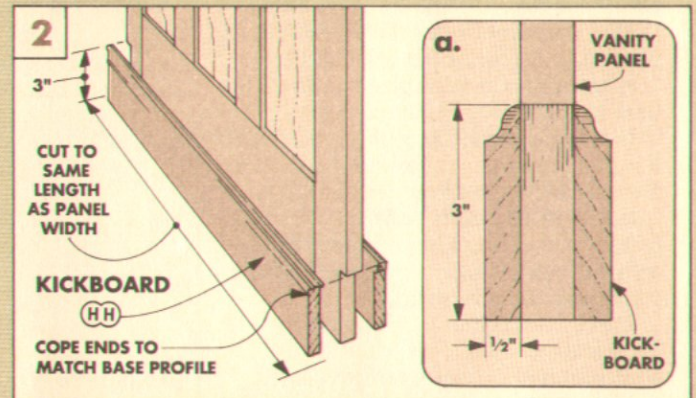
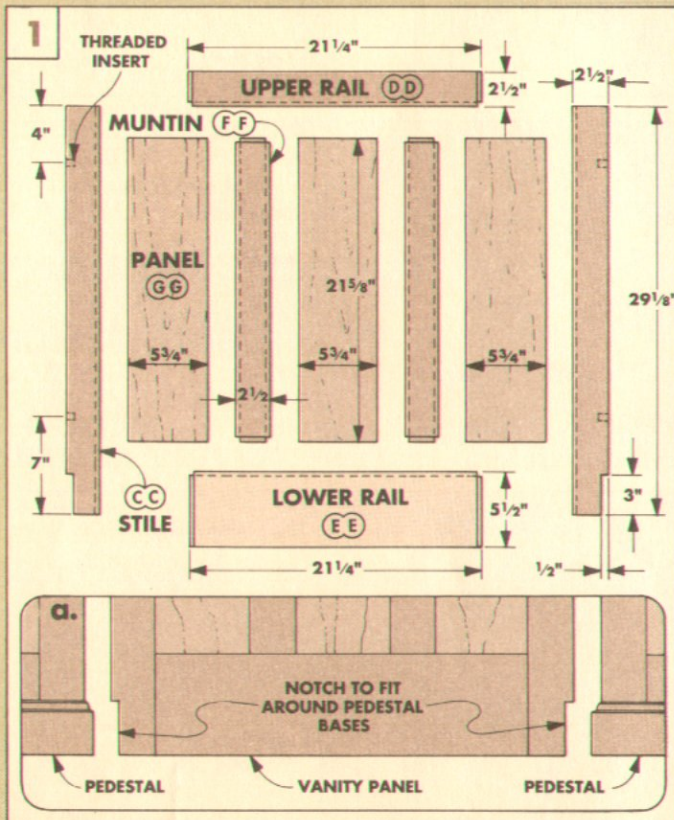

THE TOP



With the pedestals finished, the final part to build is the top. It's a large frame and panel assembly — only in this case, the panels and frame are 1" thick. (I built the panels by laminating 1/4" plywood to 3/4" particleboard).

FRAME. Start by cutting the frame pieces (II, JJ, KK) to size, see Fig. 18.

Next, cut a 1/2"-wide by 1/2"-deep offset groove on the inside edge of the front and back pieces (II) and the ends (JJ), see Detail Fig. 18. Then cut grooves on both edges of the dividers (KK). To finish the frames, cut tenons to fit the grooves on both ends of the end pieces (JJ) and dividers (KK).

BASE PANELS. Though the top panels are made of two layers, I found it easiest to build the frame around the 3/4"-thick particleboard, and then add the 1/4"-thick plywood (and inlay strips) after the frame was assembled, refer to Fig. 21. At this time, cut the 3/4" particleboard base panels (LL, MM) to size, see Fig. 18.

OFFSET TONGUES. Next, cut tongues on all four edges of the panels to fit the grooves in the frame, see Detail in Fig. 18. Note: The tongues aren't centered on the thickness of the particleboard, but offset so the top panels are flush with the top of the frame.

After the frame pieces and panels are cut, you can assemble the top, see Fig. 19.

ROUT OGEE. Once the glue has dried, the next step is to rout a Roman ogee on the outside edges of the top, see Fig. 20. I routed this freehand, using the same bit as I did for the base and drawer fronts, see Fig. 20a.

INLAY STRIPS AND PANELS. Now the recess on top of the base panels can be filled with 1/4" oak plywood surrounded by thin inlay strips (I used walnut), see Fig. 21.

Start by cutting the inlay strips (PP) 1/4" thick and 1/8" wide. Then miter them to fit snugly around the edges of the recesses.

After gluing the inlay strips in place, the inlay panels (NN, OO) can be cut to fit inside the strips. (Note the grain direction.) Fitting these is tricky. Start by cutting the panels slightly oversize. Then sneak up on the exact fit. Finally, glue the panels in place.

ATTACHING THE TOP. Once the top is finished, I attached it to the pedestals using "figure 8" desk top fasteners, see Fig. 22.

To mount the fasteners, first drill shallow mortises on top of the pedestals and support blocks (RR) with a Forstner bit, see Fig. 22. Then screw in the fasteners. Now, center the top on the pedestals, and screw through the fasteners into the top, see Fig. 22a.

FINISHING. To finish the desk, I used Minwax Fruitwood stain, and two top coats of General Finishes' Royal Finish (Satin).

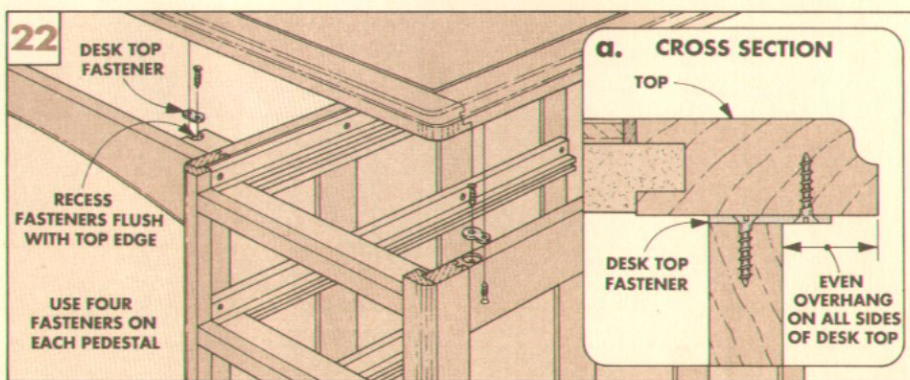
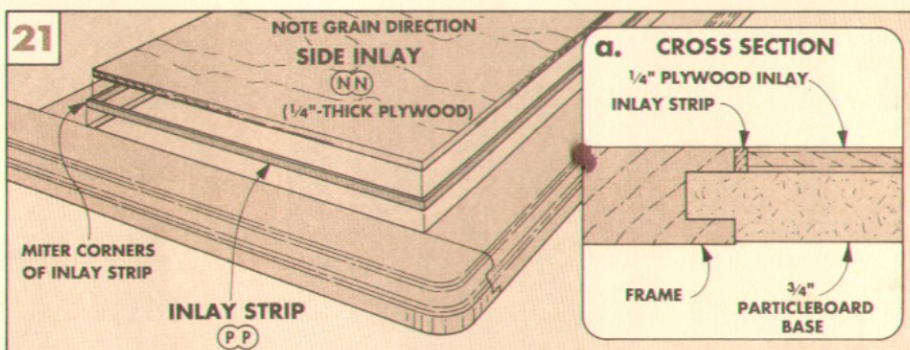
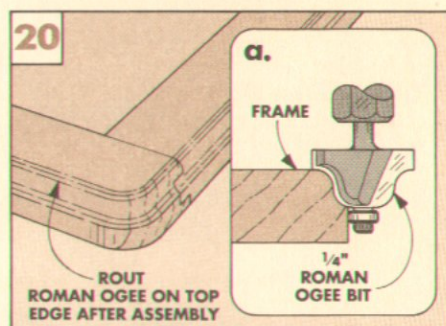
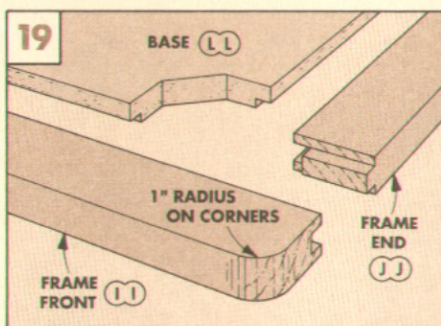
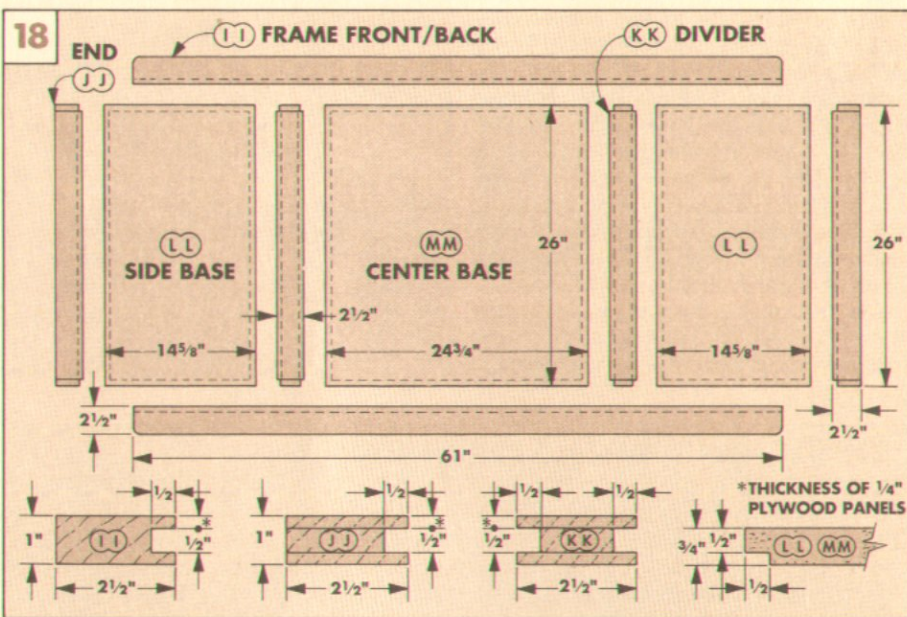

MATERIALS

BASE

- A Kickbd. Fr./Bk. (4) 1 x 3 - 17⁵/₈
 B Kickbd. Sides (4) 3/4 x 3 - 27¹/₄

SIDES

- C Stiles (8) 3/4 x 2 - 27¹/₈
 D Upper Rails (4) 3/4 x 2¹/₂ - 23¹/₂
 E Lower Rails (4) 3/4 x 3¹/₂ - 23¹/₂
 F Muntins (8) 3/4 x 2¹/₂ - 21⁵/₈
 G Panels (12) 1/4 ply - 6¹/₂ x 21⁵/₈

BACKS

- H Stiles (4) 3/4 x 2¹/₂ - 27¹/₈
 I Upper Rails (2) 3/4 x 2¹/₂ - 12¹/₈
 J Lower Rails (2) 3/4 x 3¹/₂ - 12¹/₈
 K Muntins (2) 3/4 x 2¹/₂ - 21⁵/₈
 L Panels (4) 1/4 ply - 5 x 21⁵/₈

FRONTS/DRAWER GUIDES

- M Front Stiles (4) 3/4 x 1¹/₄ - 26³/₈
 N Runners (18) 3/4 x 1¹/₈ - 26³/₈
 O Rail Supports (9) 3/4 x 1¹/₄ - 13⁵/₈
 P Front Rails (9) 3/4 x 3/4 - 14¹/₈
 Q Guides (16) 9/16 x 3/4 - 26³/₈
 R Stops (6) 3/4 x 3/4 - 2

WRITING SLIDES

- S Panels (2) 3/4 x 14 - 26¹/₄
 T Handles (2) 3/4 x 2 - 14

DRAWERS

- U Fronts (8) 3/4 x 5¹/₄ - 14
 V Sides (12) 1/2 x 5¹/₄ - 23⁵/₈
 W Backs (6) 1/2 x 5¹/₄ - 14
 X Bottoms (6) 1/4 ply - 13¹/₂ x 23¹/₂
 Y File Drwr. Fr./Bk. (2) 1/2 x 9³/₄ - 13
 Z File Drwr. Sides (2) 1/2 x 9³/₄ - 25⁵/₈
 AA File Drwr. Spacer 3/8 x 7/8 - 14
 BB File Drwr. Bottom 1/4 ply - 12¹/₂ x 25¹/₂

VANITY PANEL (OPTIONAL)

- CC Stiles (2) 3/4 x 2¹/₂ - 29¹/₈
 DD Upper Rail 3/4 x 2¹/₂ - 21¹/₄
 EE Lower Rail 3/4 x 5¹/₂ - 21¹/₄
 FF Muntins (2) 3/4 x 2¹/₂ - 21⁵/₈
 GG Panels (3) 1/4 ply - 5³/₄ x 21⁵/₈
 HH Kickboards (2) 1/2 x 3 - 26 rgh

TOP

- II Frame Fr./Bk. (2) 1 x 2¹/₂ - 61
 JJ Frame Ends (2) 1 x 2¹/₂ - 26
 KK Dividers (2) 1 x 2¹/₂ - 26
 LL Side Base (2) 3/4 prbd - 26 x 14⁵/₈
 MM Center Base 3/4 prbd - 26 x 24³/₄
 NN Side Inlay Ply (2) 1/4 ply - 24³/₄ x 13³/₈
 OO Center Inlay Ply 1/4 ply - 24³/₄ x 23¹/₂
 PP Inlay Strips (12) 1/8 x 1/4 - cut to fit
 QQ Arch. Supports (2) 3/4 x 4 - 25³/₄
 RR Support Blocks (4) 1¹/₂ x 2 - 3

SUPPLIES

- (8) Drawer Pulls
- 1/2" Nylon Drawer Glide Strips
- File Drawer Slide Hardware (Optional)
- (110) #6 x 1" Fh Woodscrews
- (4) 1/4" x 3¹/₂" Carriage Bolts, Nuts & Wshrs
- (4) 1/4" x 1¹/₄" Machine Screws & Wshrs
- (4) 1/4" Threaded Inserts
- (8) Desk Top Fasteners

CUTTING DIAGRAMS

1" x 7" - 96" (TWO BOARDS @ 4.7 Bd. Ft. Each)

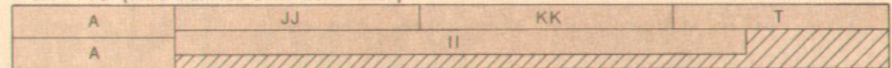

3/4" x 7" - 96" (TWO BOARDS @ 4.7 Bd. Ft. Each)

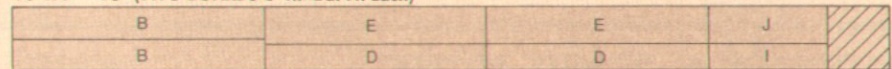

3/4" x 6" - 96" (FOUR BOARDS @ 4 Bd. Ft. Each)

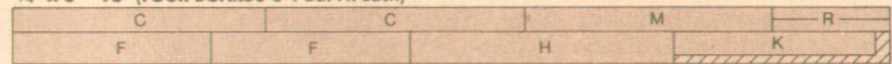

3/4" x 7" - 96" (TWO BOARDS @ 4.7 Bd. Ft. Each)

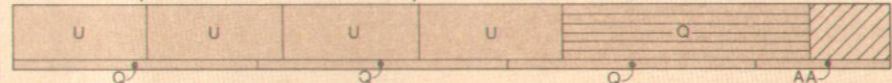

3/4" x 7 1/2" - 96" (THREE BOARDS @ 5 Bd. Ft. Each)

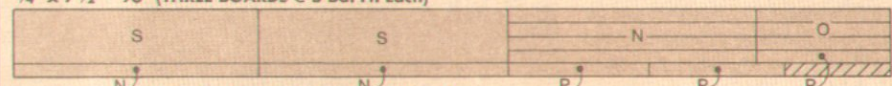

1/2" x 6" - 96" (THREE BOARDS @ 4.5 Sq. Ft. Each) Poplar

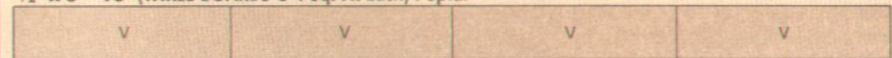

1/2" x 9 3/4" - 72" (THREE BOARDS @ 4.9 Sq. Ft. Each) Poplar

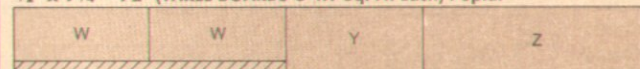

3/4" x 5 1/2" - 96" (3.7 Bd. Ft.)

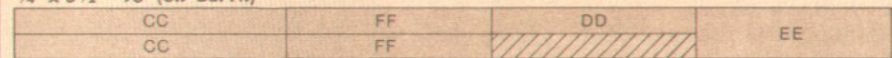

3/4" x 4" - 96" (2.7 Bd. Ft.)

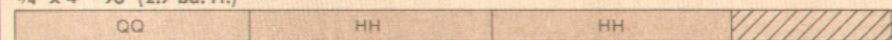

ALSO NEED 1/8" x 1/4" - 22' CONTRASTING WOOD FOR TOP INLAY STRIPS (PP)
 AND ENOUGH 1 1/2" STOCK FOR SUPPORT BLOCKS (RR)

1/4" x 48" x 96" OAK PLYWOOD (GOOD TWO SIDES)

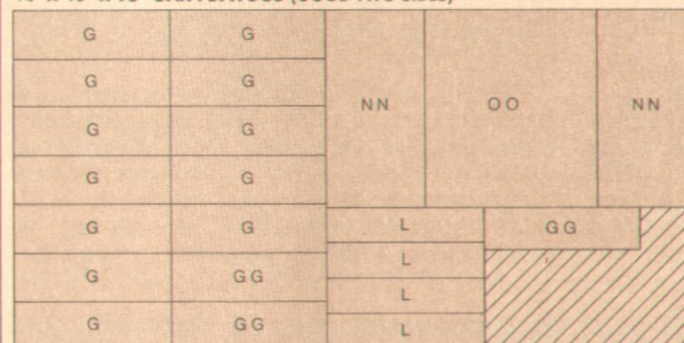

3/4" x 48" x 48" PARTICLEBOARD

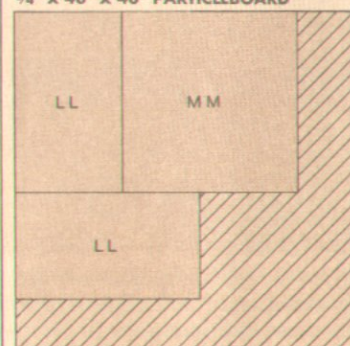

1/4" x 48" x 72" BIRCH PLYWOOD

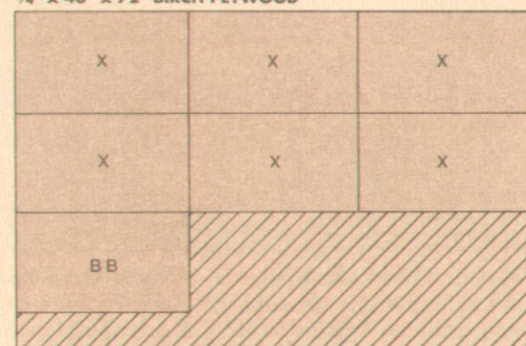

Shop Notes

CUTTING A COPED JOINT

■ When I was installing the vanity panel on the Pedestal Desk on page 6, I ran into a situation often faced by house trim carpenters — joining two pieces of molding at an inside corner. The trick is getting a good, tight fit.

MITERS. Can't you just join the two pieces with a miter joint? On the Desk I couldn't do this, since the kickboard on the pedestal runs through and beyond the vanity panel. But even on a typical inside corner there are a couple of problems with using a miter joint.

On an inside corner it's almost impossible to nail or clamp the two mitered pieces together tightly. And, even if you could fit them together fairly tight, there's a good chance a gap would develop in the corner as the wood shrinks and swells.

Since you'll be looking down into the corner, any gap will be noticeable. And if the corner isn't perfectly square (and often it's *not*) it's difficult to get a tight-fitting miter joint.

COPED JOINT. On a coped joint one of the mating pieces is cut (coped) to match the shape of the other. The other piece has a square end that's hidden behind the coped piece. Yet from above, it still appears that both are mitered, see photo above.

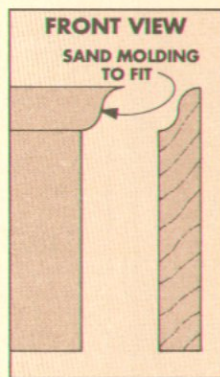
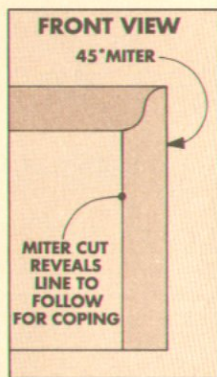
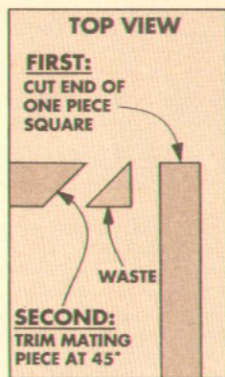
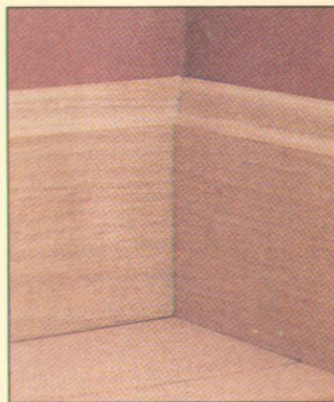

The first step in making a coped corner is to attach the square-end piece. (On the Desk, this is the pedestal base.)

CUT MITER. Now the mating piece (the vanity panel kickboard) is mitered. The purpose

of this miter is to show where to cut around the molded edge, see middle drawing above.

First mark across the end to indicate the inside limit of the miter, see Step 1 below. To make this mark on the kickboard, I

placed the two pedestals on my bench overhanging the bench top, and the pedestals separated by the arched support piece.

Next, cut a 45° miter outside the pencil mark across each end of the kickboard.

BEGIN COPING. Now the actual coping can begin. For this I use a coping saw with a new blade. (You could use a band saw with a narrow blade, or a scroll saw.) The first section to cope is the straight section, see Step 2.

Shop Note: It's easiest to see the cutting line if the workpiece is positioned so there's a shadow cast on the mitered end.

When you reach the molded edge, stop. Then make a second cut, this time cutting in from the end of the piece to remove the waste block, see Step 2.

COPE MOLDED EDGE. Here's where the tricky part comes — coping the molded edge. The secret is to take your time and cut with smooth strokes, see Step 3. But don't expect a perfect fit with the mating piece when you're done coping.

SAND TO FIT. After both ends of the kickboard have been coped, test-fit the coped piece. To get a perfect fit — a tight joint line — carefully sand across the coped ends, see Step 4.

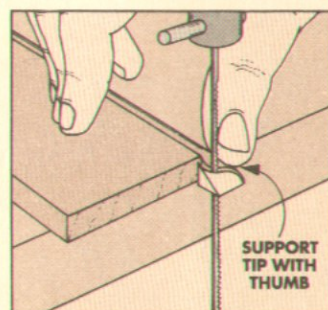
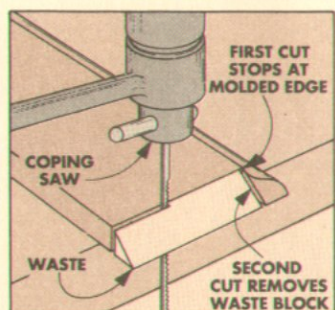
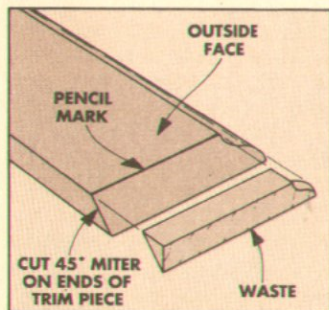

1 First mark the distance between the pedestal bases on the ends of the molding piece. Now miter the ends.

2 Make a straight cut along the miter line and stop at the molded edge. Remove waste

3 Cut around the molded edge, supporting the tip with your finger, keeping a sharp point on the tip of the molding.

4 Now test the fit to the mating piece. Use a sanding stick to smooth the end so it fits tightly along the entire joint.

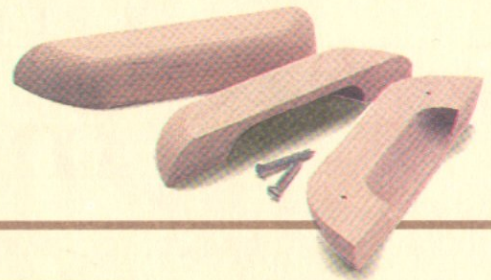

SHOP-MADE DRAWER PULLS

■ There's a good reason for making your own drawer pulls on a project such as the Pedestal Desk on page 6. If you use stock left over from making the drawer fronts, the pulls will match the drawers.

ROUTED BLANKS. The drawer pulls I made for the Desk started out as pieces of drawer stock that are cut to length and width, then routed to shape.

DOUBLE-ENDED JIG. To make the routing operations safer, I built a jig to hold the blank while routing on the router table, see drawing at right. This also helps to produce pulls that are identical in shape and size.

The neat thing about this jig is that it's double-ended to serve two purposes. One end holds the

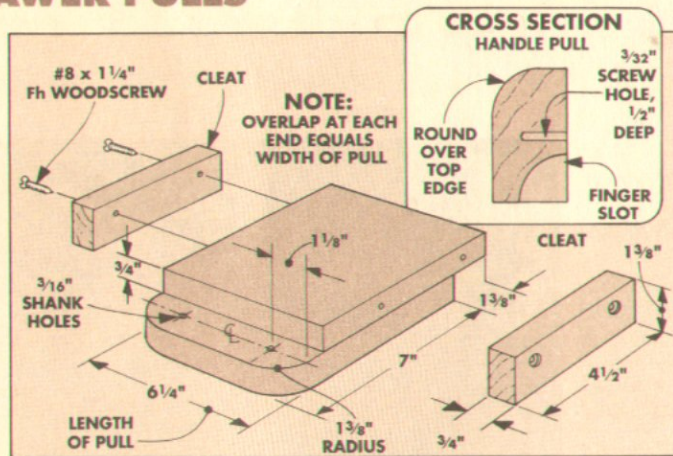

blank for routing a cove for a finger slot. Then the workpiece is screwed to other end of the jig for trimming the corners flush and rounding over the edges.

MAKING THE JIG. The jig is simply a pair of $\frac{3}{4}$ "-thick pieces of scrap cut to the desired length of the pulls ($6\frac{1}{4}$ " in my case). The pieces are then glued to-

gether with an equal amount of overhang at each end, see drawing at left. The width of the overhang matches the desired width of your pulls (in my case, $1\frac{3}{8}$ ").

Two screw holes through the overhang hold the workpiece while routing the edge. These leave mounting holes in the pull.

CLEATS. In order to keep the blank in place while routing the cove for the finger slot, screw a pair of $\frac{3}{4}$ "-thick cleats to the sides of the jig, see Step 1 below.

RADIUS. I cut a radius on the front corners of the jig to serve as a pattern for the pilot bearing on a flush trim router bit, see Step 5. Then, after trimming the blank to match the jig, switch to a $\frac{1}{2}$ " round-over bit and rout the outside edges, see Step 6.

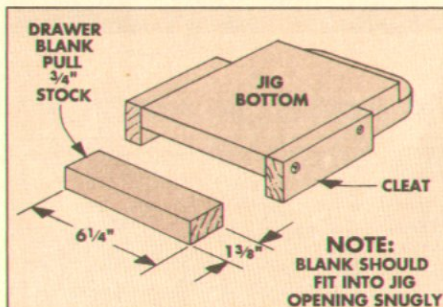

1 First cut the blanks to length and width. Then, to rout a cove for the finger slot, slide one blank into the jig. It should fit snugly between the side cleats.

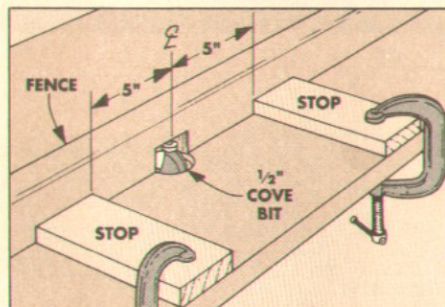

2 Clamp a pair of stops to the router table an equal distance from the center of the bit. This distance determines the travel of the workpiece, and the slot length.

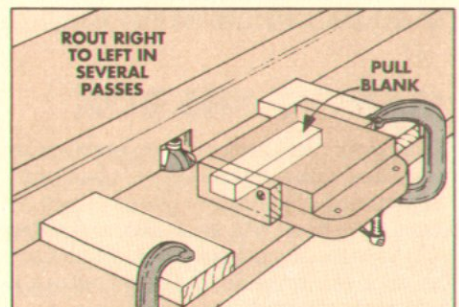

3 Now adjust the bit to cut full-depth, and slide the fence up to the outside edge of the bearing. Make several light passes from right to left to rout the slot.

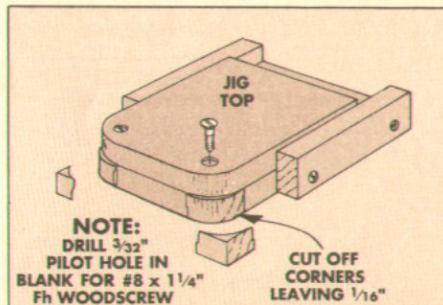

4 Use the other end of the jig to shape the front of the pull. First, screw the blank to the jig. Then cut off the "ears," leaving $\frac{1}{16}$ " that's flush trimmed next.

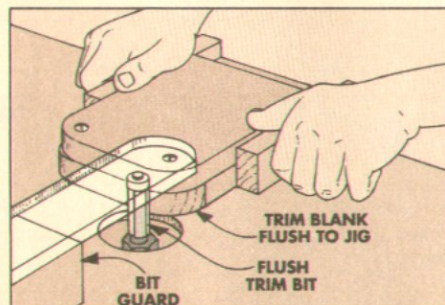

5 Now, with a flush trim bit in the router, trim the corners and front edge flush with the jig. Do this on all the drawer pulls before going to Step 6.

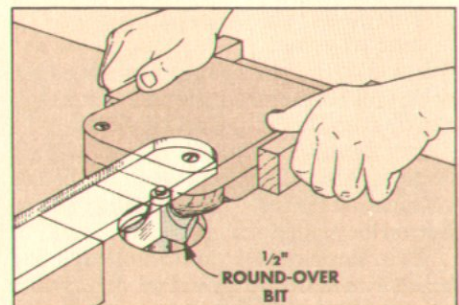

6 With a $\frac{1}{2}$ " round-over bit in the router table, raise the bit to full cutting depth. Make several light passes to round over the front and ends of the pull.

In/Out Box

Round corners aren't the only unique thing about this project. The sides of the box are the same thickness as the corners. And the fingers of the box joints seem to bend around the corners.

When you first see this In/Out box, you might think it's another wood-bending project. The $\frac{1}{4}$ "-thick fingers of the box joints seem to wrap around the round corners of the box.

So how do you "bend" the fingers of a box joint? The trick is to start with $\frac{3}{4}$ "-thick stock. Then, after the box joints are cut and the box is assembled, a radius is cut on the outside and inside of each corner. The result? Box joints that look like they're turning a round corner.

As it turned out, "bending" the fingers was easy. The challenging part was figuring out how to thin the sides of the box (after it was already assembled) to match the thickness of the round corners. To do this, I made a routing platform that clamps to the benchtop. Then I used a slightly unorthodox "plunge and nibble" routing technique.



MAKING THE BOX

The in/out box starts out as a rectangular box joined with standard $\frac{1}{4}$ "-wide box joints (sometimes called finger joints). Begin by cutting the front (A), back (B), and sides (C) to finished length and rough width from $\frac{3}{4}$ "-thick stock, see Fig. 1. (I used red oak.)

CUT BOX JOINTS. Now the box joints can be cut, see Fig. 1a. To do this, I set up a $\frac{1}{4}$ " dado blade on the table saw and cut the slots using a box joint jig. (There's an article on making a jig and cutting box joints in *Woodsmith* No. 78. For information on ordering this issue and hardware to make the jig, see page 31.)

TRIM TO WIDTH. After cutting all the box joints, trim the pieces to final width on the table saw. Set the fence to leave a full pin (for the front and back) or slot (for the sides).

CUT HAND OPENING. It's easiest to cut a hand opening in the front piece (A) before assembling the box. To do this, first center a line on the length of the piece, see Fig. 2.

Then measure $1\frac{1}{4}$ " from the top edge, and make a mark on the centerline. Now scribe an arc with a 4" radius that intersects this point. Next, cut along this arc with a band saw or sabre saw to form the hand opening.

ASSEMBLE BOX. Finally, glue and clamp the box together and check for square.

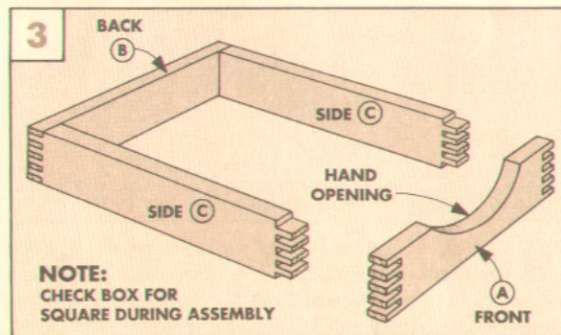
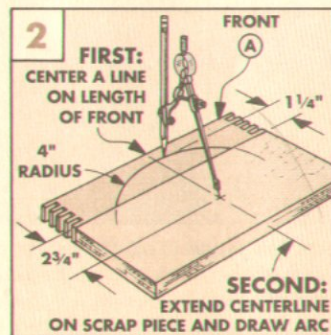
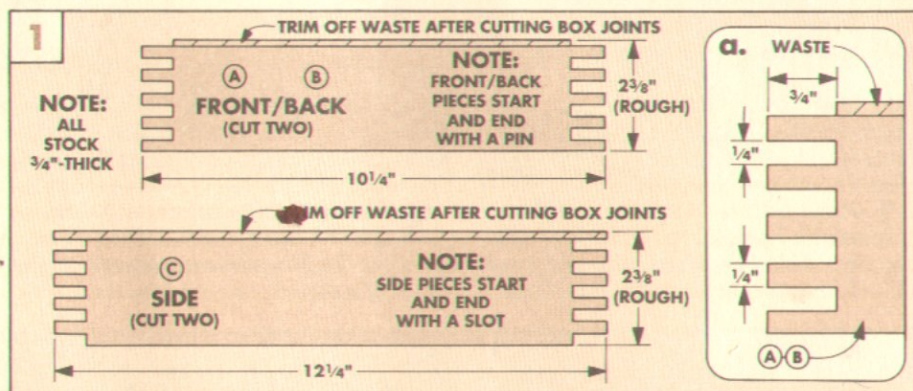

ROUNDING THE CORNERS

After the box is assembled, the corners can be rounded. This is a two-step process. First, there's a hole drilled on the *inside* of each corner. Then a radius is sanded on the *outside* of each corner.

INSIDE CORNER. I drilled the inside corner holes with a 1" Forstner bit on the drill press. The key is to position the box under the bit so each corner has sides of identical thickness, refer to Fig. 6a. To do this, I made a positioning "corner" on the drill press table with a fence and a stop block, refer to Fig. 6.

To position the corner, use a spacer the same thickness as the desired thickness of the box sides. (I used 1/4" Masonite.) Place the spacer against the back edge of the bit, see Fig. 4. Then position the fence against the spacer, and clamp the fence down.

Next, place the 1/4" spacer against the right side of the bit, and set a stop block against the spacer, see Fig. 5. Now clamp the stop block to the fence.

GUIDE BLOCK. To keep the bit from veering off into the box, I clamped a guide block to the inside of the box, see Fig. 6.

DRILL INSIDE HOLES. Now you can drill the holes. Drill halfway through from one side, then flip the box over and complete the holes from the other side.

ROUND OUTSIDE CORNERS. The last step is to round the outside corners, see Fig. 7. To do this, I made a template and marked and sanded each corner on a disk sander.

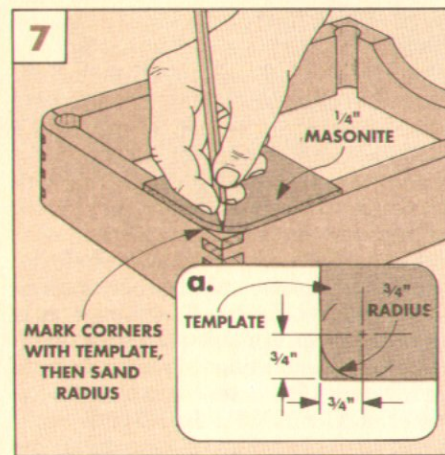
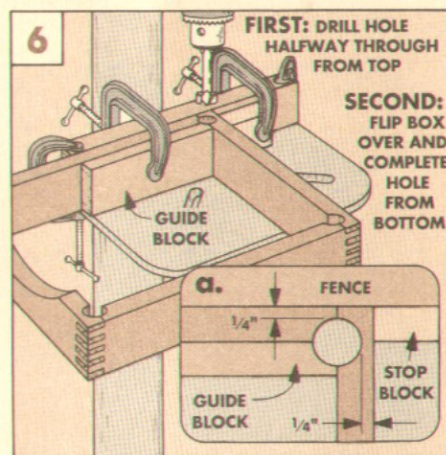
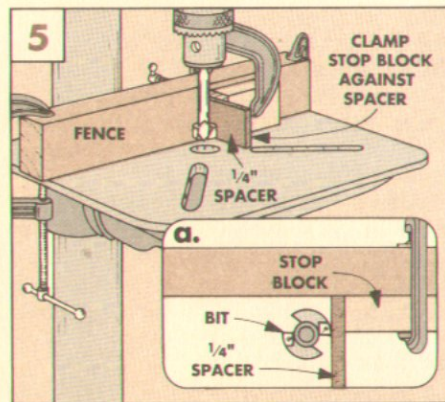
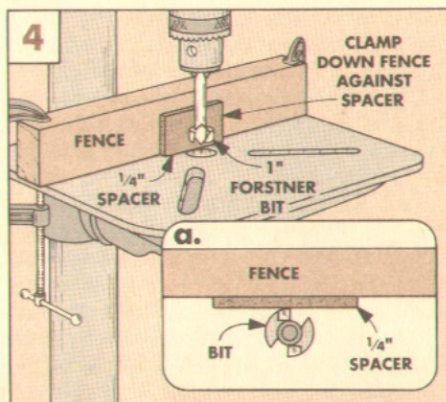

ROUTING PLATFORM

Now that the corners are rounded, the next step is to thin the sides of the box to match the thickness of the corners.

To thin the sides, I used a router and 3/4" straight bit. (You could also use a 1/2" straight bit.) But the problem was supporting the router base and keeping it from tipping during the cut. To get around this, I made a routing platform that clamps to the workbench. The platform consists of a top, a base (see Fig. 8), and a fence (see Fig. 9).

TOP. To make the platform, I first cut a top from 3/4" plywood to a width of 11" and length

of 19", see Fig. 8. This should be long enough to support the router at either corner of the box, and wide enough to allow the platform to be clamped to the bench, see Fig. 9.

BASE. The base provides a clamping surface for the in/out box, refer to Fig. 10 on the next page. To make the base, rip a 2x4 to a width of 2", and then glue and screw it to the front bottom edge of the top, see Fig. 8.

FENCE. The last step is to make a fence to guide the base of the router. First I cut a straight piece of wood to the same length as the top. Then, to make the fence adjustable,

drill 1/4" shank holes at each end for No. 8 roundhead woodscrews, see Fig. 9.

LOCATE FENCE. To locate the fence, I used the same 1/4" spacer as I used on the drill press setup. First, hold the spacer against the base of the platform, see Fig. 9a.

Then, set your router on the platform so the edge of a 1/2" or 3/4" straight bit is against the spacer, and position the fence against the base of the router. Clamp this end of the fence in place, and locate the other end the same way. Now, screw the fence to the top of the platform and remove the clamps.

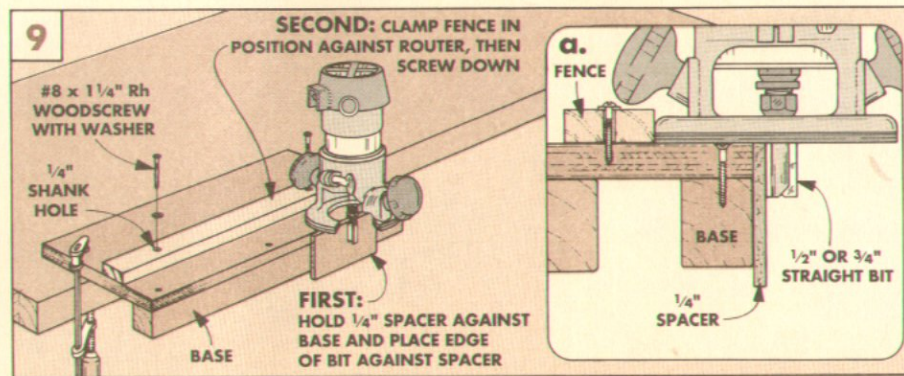
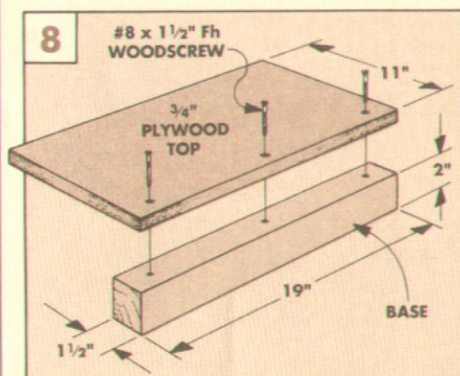

THINNING THE SIDES

After finishing the routing platform, the sides of the box can be thinned to match the thickness of the corners.

CLAMP BOX. To do this, first clamp the box to the routing platform, see Fig. 10. The top edge of the box should be flush with the top surface of the routing platform.

ADJUST FENCE. You've already set the fence on the routing platform to leave $\frac{1}{4}$ "-thick sides. But to be on the safe side, nudge the fence *toward* the box a hair (which will make the sides slightly thicker). Then you can readjust the fence later to sneak up on the final thickness.

SET DEPTH OF CUT. I set the router bit to make a $1\frac{1}{4}$ "-deep cut (just over half the width of the box). That way, each side can be thinned by routing the top first and then the bottom without having to readjust the bit. (Note: If your router bit won't cut $1\frac{1}{4}$ " deep, you'll have to make the cuts in two passes.)

PLUNGE AND NIBBLE. But making that deep a cut presents a problem. Routing with the rotation of the bit (left to right), you risk tearing out a long splinter. So instead, I settled on a "plunge and nibble" technique. This method involves making a series of side plunge cuts, see Fig. 10a. Each plunge cut is followed by a short nibble or clean-out cut.

To thin the side using a plunge and nibble technique, set the router on the platform top so the bit is $\frac{1}{2}$ " to $\frac{3}{4}$ " to the left of the *right* corner of the box. Then plunge the router toward the fence until the fence stops the

router base. Now nibble away any wood that's left between the plunge cut and the right corner by routing from left to right.

For the second plunge cut, just move the router another $\frac{1}{2}$ " to $\frac{3}{4}$ " to the left of the first cut. Note: The router bit isn't cutting as the router is advanced.

Then plunge and nibble again. Now repeat this sequence until the top half of the side is thinned. After the last plunge cut, make a final pass to clean up any ridges, see Fig. 10a. Shop Tip: To ensure consistent thickness, always orient the router the same direction while routing, see box at right.

After the top half is routed, flip the in/out box over and rout the bottom half. Then thin the remaining three sides.

ROUTER POSITION

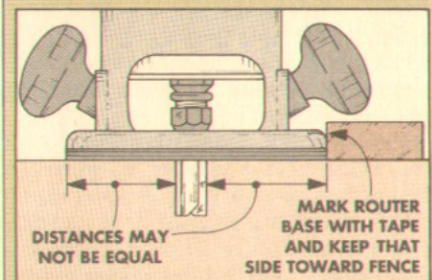

On some routers, the bit may not be exactly centered on the base. So, to keep the cut a uniform thickness when using a fence, keep one point on the router base against the fence throughout the cut.

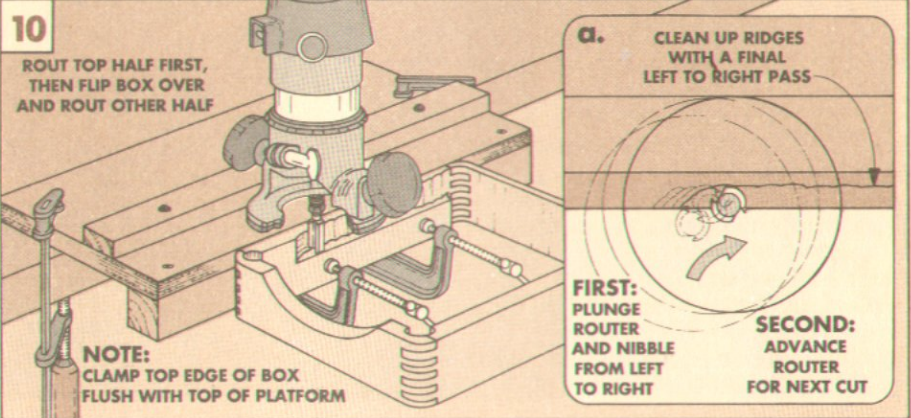

ADDING THE BOTTOM

Now that all the sides and corners are a uniform thickness, the last step is to rout a $\frac{1}{8}$ "-wide rabbet in the bottom inside edge of the box for a $\frac{1}{4}$ " plywood bottom.

I cut this rabbet on the router table using a $\frac{1}{4}$ " straight bit and a rub block, see Figs. 11 and 12. The end of the rub block acts like a fence, keeping the rabbet a consistent width.

To make the rub block, glue a piece of $\frac{3}{4}$ " plywood to a spacer made of $\frac{1}{4}$ " Masonite, and cut as shown in Fig. 11. Then line the spacer with double-sided carpet tape to at-

tach the rub block to the router table.

POSITION RUB BLOCK. To position the rub block on the router table, first adjust the router bit to a height of $\frac{1}{4}$ ", see Fig. 12a. Then center the end of the rub block over the bit, leaving $\frac{1}{8}$ " (the desired width of the rabbet) exposed and press the block into place.

ROUTER RABBET. With the rub block in place, you can rout the rabbet. To reduce chipout, I made several light passes. This works well for the sides, but the corners are a bit touchy.

To prevent chipping out one of the finger

joints in the corners, I used the plunge and nibble method again. But this time, I only nibbled away about $\frac{1}{8}$ " at a time.

BOTTOM. After the rabbet is cut, use it as a template to draw the bottom of the box on a piece of $\frac{1}{4}$ " oak plywood. (It's actually a little less than $\frac{1}{4}$ " thick.) Then cut the bottom, and glue and clamp it to the box, see Fig. 13a.

FINISH. Finally, I sanded the box and finished it with General Finishes' Royal Finish (satin). Once it was dry, I added a self-adhesive felt dot to each corner, see Fig. 13.

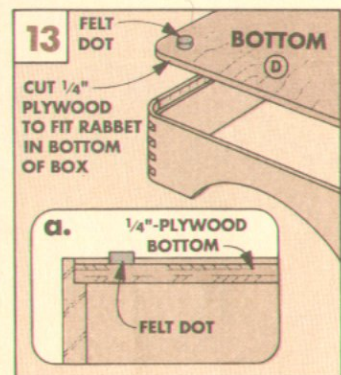
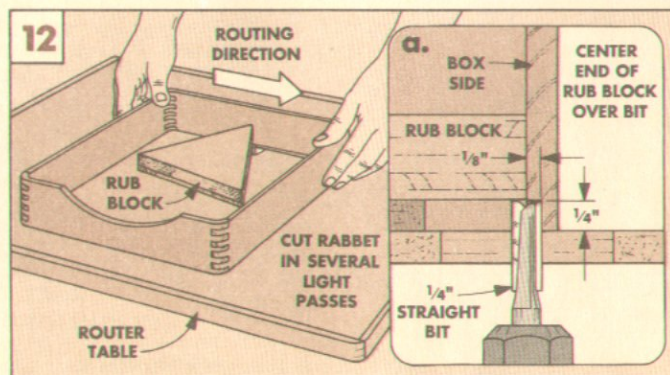
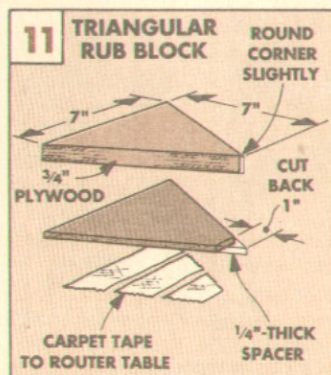

STACKED BOXES

The finished In/Out Box can stand by itself on any desk. But after making all the setups for the first box, it only takes a little more time and material to build a second box. Then, by making four support arms, you can stack the two boxes in a typical in/out tray arrangement, see photo.

SUPPORT ARMS. The support arms are just pieces of 1/2" dowel rod (I used red oak) that are cut to a length of 6 3/4", see Fig. 14. Then, a bare-faced or single-shouldered tenon is cut on each end.

The support arms work like this. The shoulder of the bottom tenon on each dowel rests on the top edge of the lower box, refer to Fig. 17. And the shoulder of the upper tenon holds the top box in place.

But cutting these tenons on the ends of a round dowel can be a problem. For the faces of both the top and bottom tenons to sit flat against the box, the tenons must be directly in line with each other, refer to Fig. 17.

How do you cut two identical tenons on a round dowel that has a tendency to roll? To do this, I made a jig that holds each dowel in place while the face and shoulder cuts are made. Since the dowel won't move in the jig, the two tenons have to be identical.

JIG. To make the jig, first cut a V-notch in the end of a scrap piece of plywood, see Fig. 14. (I tilted the table saw blade to 45° and cut the notch in two passes.) Then, to hold the

dowel in place, line the V-notch with double-sided carpet tape, and press one of the dowels into place, see Fig. 14a.

FACE CUTS. After making the jig, you can use the band saw to cut the faces of the tenons, see Fig. 15. First clamp a fence 1/4" from the blade, see Fig. 15a.

Then, to make the faces of the tenons identical length (2 1/8"—just less than the width of the box), clamp a stop block behind the front of the saw blade. Now lay the jig flat on the table and make the face cuts on both ends of the dowel. Note: Don't remove the dowel from the jig yet.

To complete the two tenons, I cut the shoulders using the miter gauge on the table saw, see Fig. 16. First, raise the blade just below the face of the tenon, see Fig. 16a.

Next, use the rip fence as a stop to cut both shoulders the same distance from the ends of the dowel, see Fig. 16a. To do this, clamp a stop block to the fence. Position the block

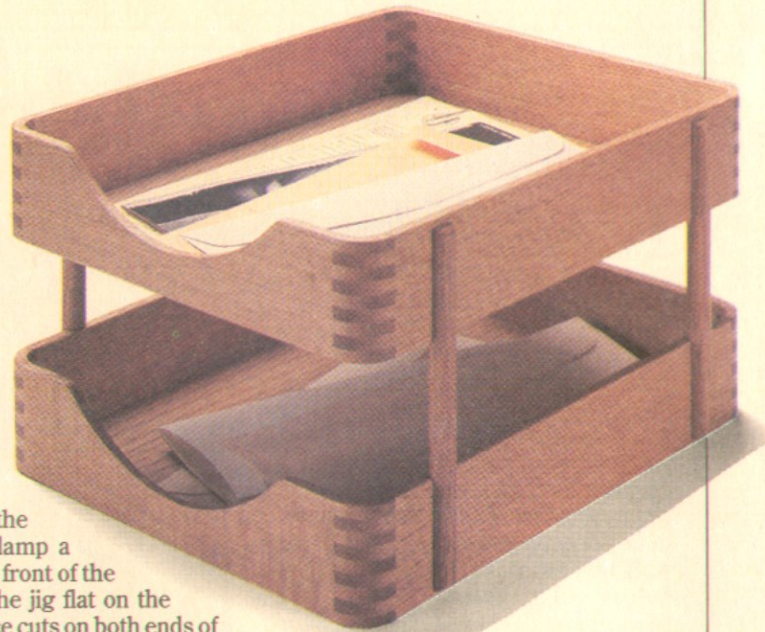

2 1/8" from the *outside* of the blade. Now lock the rip fence and cut both shoulders.

After the shoulders at both ends of the dowel are cut, you can remove the dowel from the jig. Then follow the same procedure to cut tenons on the other three dowels. Finally, soften the ends slightly by sanding, and glue the completed support arms to the two boxes, see Fig. 17.

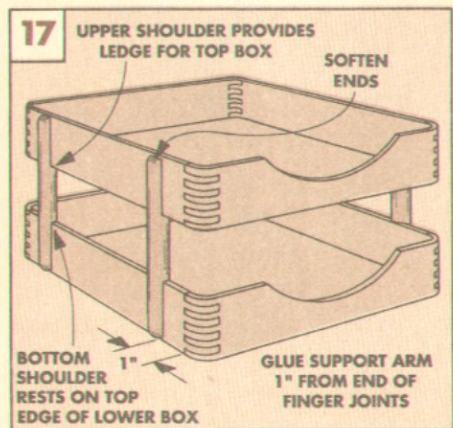
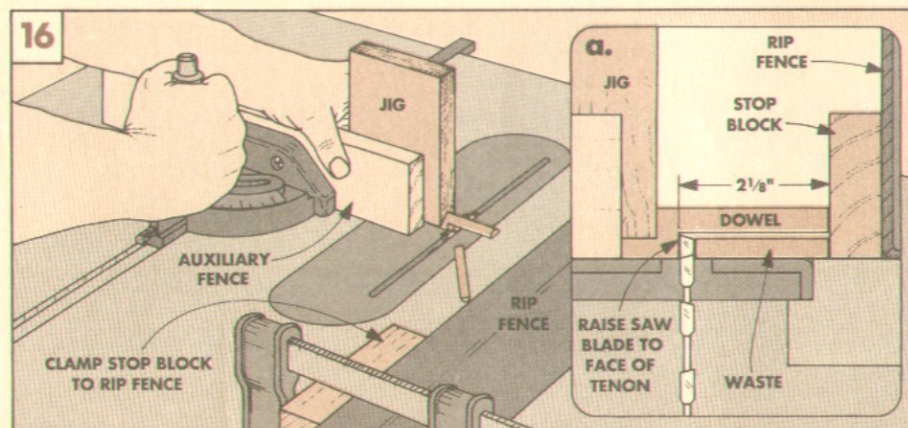
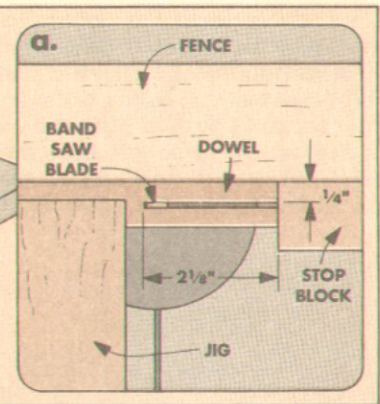
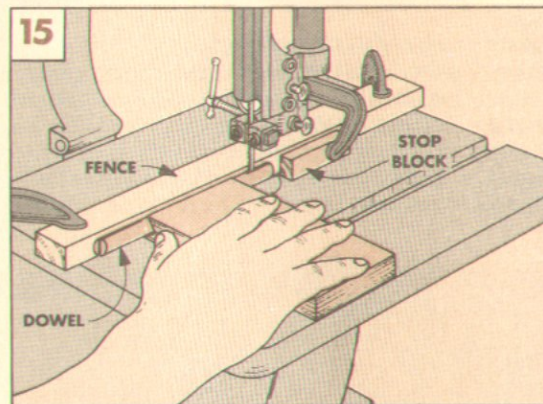
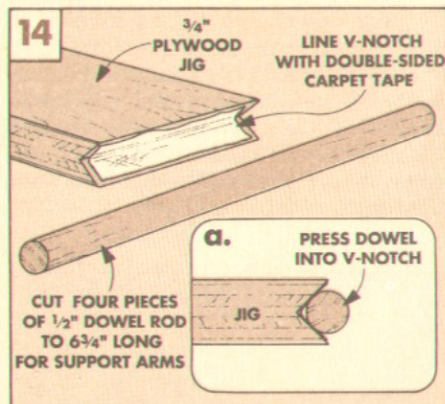

Shoulder Planes

Recently I was fitting a panel into a rabbet on the back of a cabinet. But the panel wouldn't set in flush. Obviously, I needed to do a little trimming, but how? There was no going back to the table saw because the cabinet was already assembled. And setting up a router to do the trimming would be tricky and time-consuming.

What I needed wasn't a power tool, but a hand tool—a shoulder plane, see photo. Since its cutter is as wide as its body, a shoulder plane is the perfect tool for trimming rabbets, as well as tenon shoulders, dados, and grooves.

Why not use a rabbet plane to fix a rabbet? You'll see shoulder planes listed as rabbet planes (and the other way around) in catalogs. While their names are often interchangeable, their primary uses are different. Rabbet planes are designed to cut rabbets while shoulder planes are meant to clean them up.

SHOULDER PLANE. So a shoulder plane is mainly a *trimming* tool—ideal for shaving end grain, such as the shoulders of a tenon. But it's also good for smoothing the bottom or sides of a rabbet, or even flattening the bottom of a dado or groove.

HOW THEY WORK. A shoulder plane is really just a tool that holds a cutter square to the sides, and at a low angle to the surface being planed. To do this, the sides of the shoulder plane are machined flat and square to the bottom. And the cutter "seat" is ma-

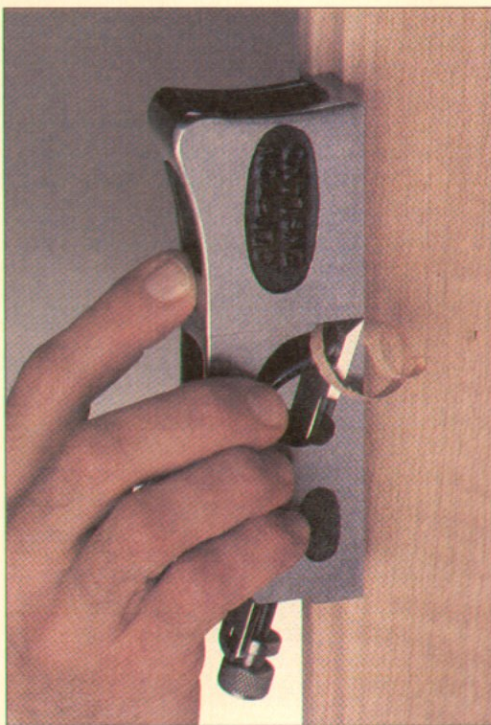

chined to 12°, see Fig. 1.

CUTTING ANGLE. But the cutting angle is actually 37° (most planes are 45°). That's figured by adding the angle of the cutter seat (12°) to the angle of the bevel on the cutter (25°). The cutter is used bevel up, see Fig. 1.

PARTS. Shoulder planes have very few

parts. In the case of the Stanley No. 93 shoulder plane shown in Fig. 1, there are only nine. The body of the plane is in two parts. The top has a long nose and is shaped like a handle at the back. The bottom is attached to the top with a locking screw, and contains the cutter seat and the adjusting slide for raising and lowering the cutter.

CUTTER ADJUSTMENT. The cutter sits on the seat and the adjusting slide, see Fig. 1. The slide itself sits on a short ramp. By turning the cutter adjusting screw, the slide (and the cutter) moves up or down the ramp, see Cross Section. Moving the cutter down the ramp exposes more of the cutting edge below the plane bottom.

The cutter is held against the seat by the lever cap. Tightening the lever cap screw forces the cutter against the seat, see Cross Section. A tightly held cutter produces a smooth cut.

MOUTH ADJUSTMENT. There's only one more part, and this one is hard to find unless you know it's there—a set screw that controls the size of the mouth, see Cross Section. Tightening the screw allows a very narrow opening which is essential for fine cross-grain trimming.

Can't you avoid using a shoulder plane by just being more careful when cutting the rabbet in the first place? Well, maybe. But even the most careful machine set-up can give some unexpected results. And that's when these planes do their best work.

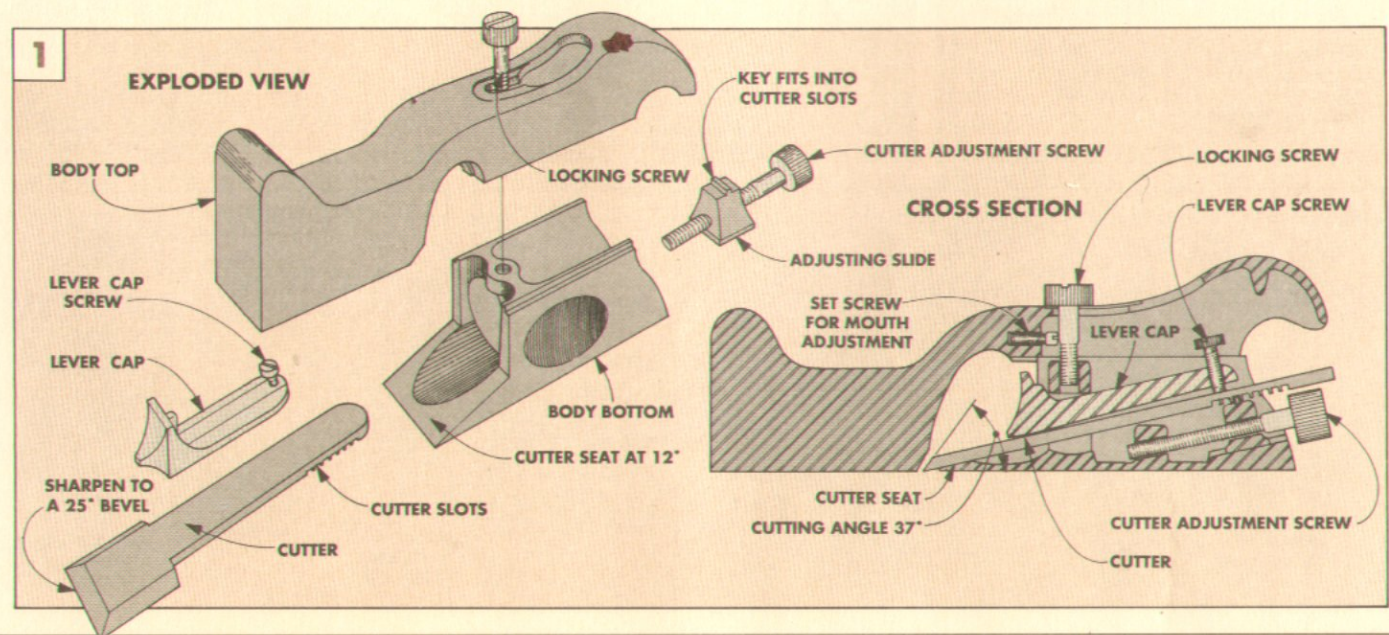

PLANE SET-UP

A new shoulder plane will probably come in a cardboard box, wrapped in rust preventive paper. Curiously, one of the things it probably won't come with is instructions for use and care. And I'd be surprised if it came out of the box ready to use. Fortunately, setting it up isn't that difficult.

WHAT TO DO FIRST. One of the first things I do with a new shoulder plane is check that the bottom and sides are flat and square. Also, on planes with two-piece bodies, check that the bottom surfaces of both pieces are in the same plane, see Fig. 2. (Pun intended.)

Minor deviations can be corrected by gently "grinding" the sole of the assembled plane on fine grit silicon carbide sandpaper mounted on a flat surface. But if the problems aren't minor, return the plane.

CUTTER. Next, compare the width of the cutter to the width of the plane body. The cutter should be slightly wider — about $\frac{1}{100}$ " to $\frac{1}{64}$ " wider. If it's wider than that, you can grind a bit off the sides of the cutter. But if it's too narrow, the plane will never cut properly. So, again, return the cutter (or the plane) for a new one.

The next step is to remove the cutter and hone the cutting edge. The cutter looks more like a flattened spoon than a typical plane iron. The nearly square end has not one, but three bevels. With luck, the cutting edge bevel is ground to 25° . If not, re-grind and then hone it to this angle.

SETTING CUTTER DEPTH. Now, set the depth of the cutter, see Fig. 2. For most work, you'll want to set the cutter to take a fine shaving. To do this, set the cutting edge slightly below the bottom of the plane (the thickness of a playing card, or less).

MOUTH OPENING. The size of the mouth opening is one of the keys to accurate trim-

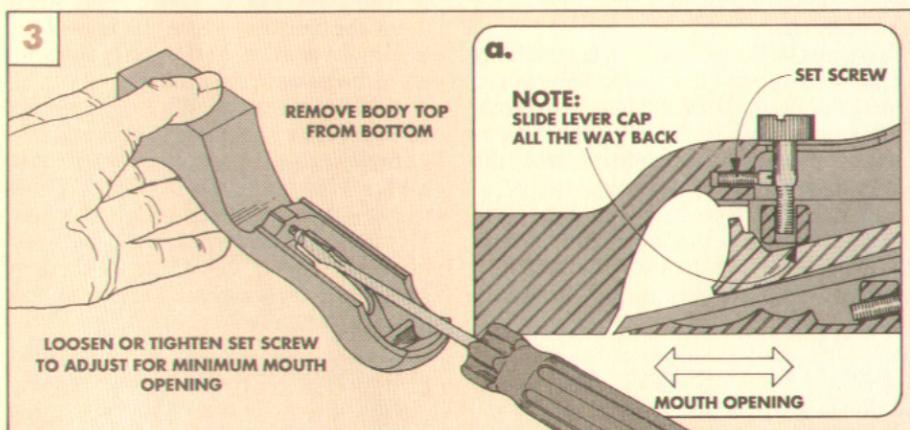
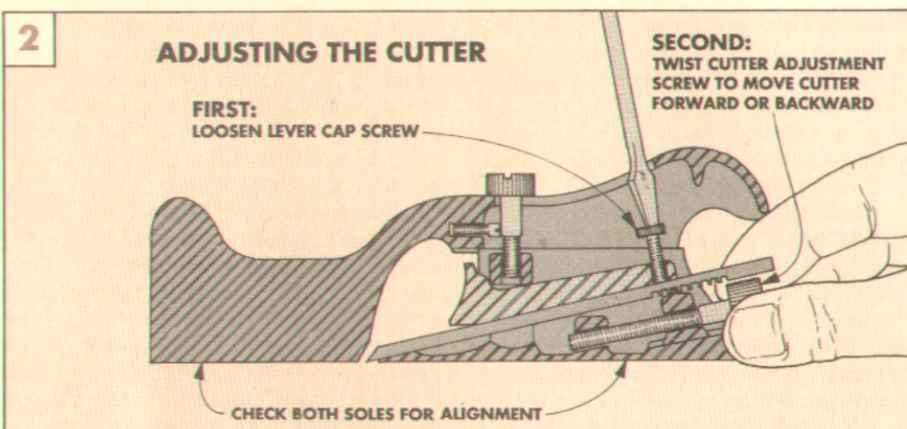

ming. For precise, delicate work it should be open enough to let only a paper thin shaving through, see Fig. 3a. To do this, adjust the set screw located in the body top, see Fig. 3.

For less precise work, the mouth can be opened wider (and the cutter set deeper). This lets in a larger shaving and you can re-

move wood faster. To do this, loosen the locking screw. Then adjust the mouth opening and tighten the locking screw. There's no need to re-adjust the set screw.

Note: Some shoulder planes, such as those made by Clifton (except the 3110), don't have adjustable mouth openings.

A COLLECTION OF SHOULDER PLANES

Here's a family photo of most of the metal shoulder planes being manufactured today. These planes represent the three major shoulder plane makers — Record, Stanley, and Clifton. The planes are made of cast iron (the Stanleys are also nickel plated) in England. No one needs all of these planes, but the range indicates there's a shoulder plane for every job, and (maybe) every budget.

The Granddaddy of the group is the Record No. 73. It's 8" long, $1\frac{1}{4}$ " wide, and weighs four pounds. The smallest is the Clifton 400. It's 4" long, $\frac{3}{8}$ " wide, and the only one to use a wedge to hold the cutter in place. The rest vary in size and weight.

For catalog information on purchasing these and other shoulder planes, see Mail Order Sources, page 31.

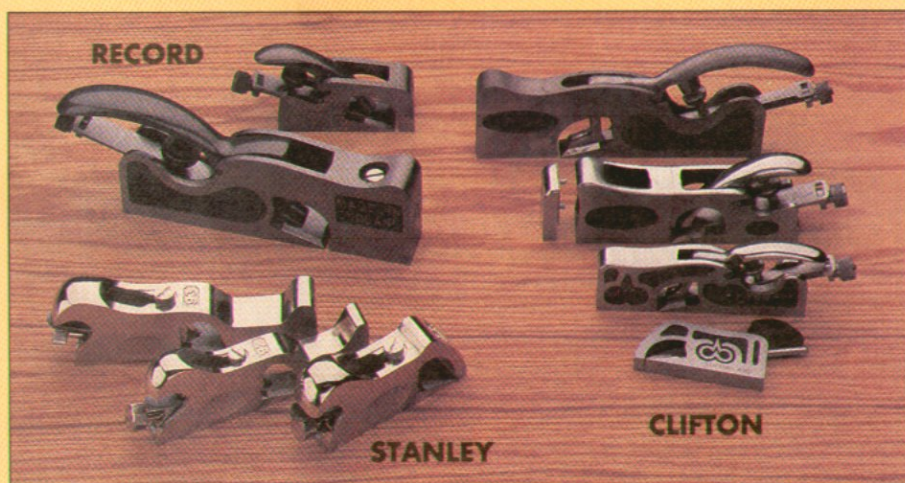

USING A SHOULDER PLANE

If you've ever cut a tenon that didn't fit as tightly in the mortise as you wanted, then you would probably appreciate a shoulder plane. Shoulder planes have two features that make it possible to make very fine cross-grain cuts—a cutter mounted at a low angle, and a very small mouth opening. Both are essential when planing across grain.

TRIMMING TENON SHOULDERS. Trimming tenon shoulders involves removing end grain stock in very fine passes, see Fig. 4. To do this, first set the mouth of the plane to a very narrow opening (if your plane has an adjustable mouth) — $\frac{1}{32}$ " or less is best.

Next, set the cutter to make a fine cut. For this, the blade should protrude very slightly below the sole. And, of course, the cutter should be sharp.

To trim the tenon shoulder, lay the body of the plane against the cheek (side) of the tenon, see Fig. 4. Then, to prevent the grain from chipping out on the edge of the workpiece, I trim across the shoulder from the outside edge toward the center.

It's important to keep the side of the plane flat against the cheek as you work. This way the shoulder will be square to the cheek.

Note: I use a shoulder plane to trim half-lap joints, too. After all, a half-lap is really a

tenon, but with only one shoulder.

TRIMMING TENON CHEEKS. In addition to squaring shoulders, there may be some other trimming to do to make a tenon fit properly. And since most of this is cross-grain work, the shoulder plane's low angle cutter makes it the ideal tool.

For example, I use a shoulder plane to trim the cheeks of a tenon, see Fig. 5. To do this, set the plane on the cheek and take a thin shaving cutting across the grain. If it's a centered tenon, pare an even amount off both sides of the tenon so it will remain centered on the thickness of the workpiece.

CHAMFERING. The last step in fitting a tenon to a mortise is to chamfer the ends of the tenon, see Fig. 6. This doesn't really change the size of the tenon, but helps it slip easily into a mortise. And it allows space for glue in the bottom of the mortise.

TRIMMING RABBETS. While a shoulder plane's primary purpose is to trim tenons, I find myself using it more often to clean up or ease the sides and bottom of rabbets. This is especially true of rabbets cut on a table saw.

To do this, I use a plane that's the same size or wider than the rabbet, see Fig. 7. Then, when trimming, hold the side of the plane against the side of the rabbet so the

bottom is cut at 90° to the side.

CUTTING RABBETS. While cleaning up rabbets cut on a saw is one of the main uses of a shoulder plane, these planes can also be used to initially cut the rabbet. To do this, start by tacking a fence on the workpiece to serve as a guide for the plane, see Fig. 8. It can be removed once the rabbet is deep enough to guide the plane without the fence.

When cutting a rabbet across the grain, I start by scoring the wood fibers with a utility knife. This avoids tearout and a ragged edge. You could also cut this shoulder line with a hand saw (and fence) first. Then remove the waste with the shoulder plane.

CLEANING UP DADOES AND GROOVES. Cutting dados and grooves on a table saw can result in a rough bottom. Sometimes this doesn't matter. But when the end of a dado or groove will show, I want a flat bottom. So I use a shoulder plane to clean it up.

Cleaning up the bottom of a dado or groove is just like working on a rabbet—except that the shoulder plane has to fit in the slot. (This is one reason there are some narrow shoulder planes made.) The trick in cleaning up dados is to hold the plane 90° to the face of the workpiece so the bottom of the dado or groove will be parallel to the face.

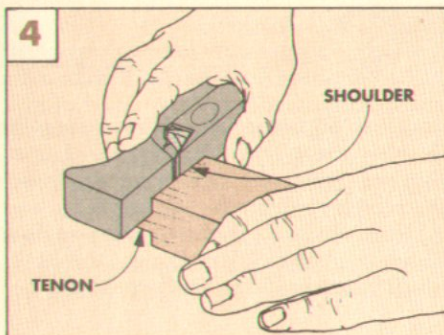

● To trim a shoulder, first set the mouth for a very small opening. Then lay the side of the plane on the tenon cheek and trim toward the center of the shoulder.

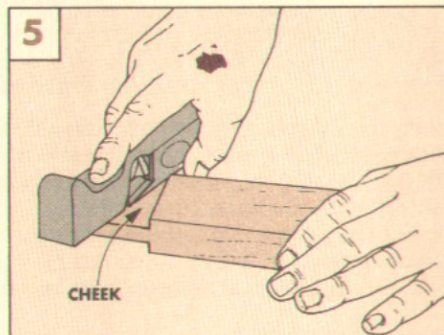

● Shoulder planes are a good choice to trim the cheeks of a tenon, also. To do this, plane across the grain in light passes. Take an equal amount off both cheeks.

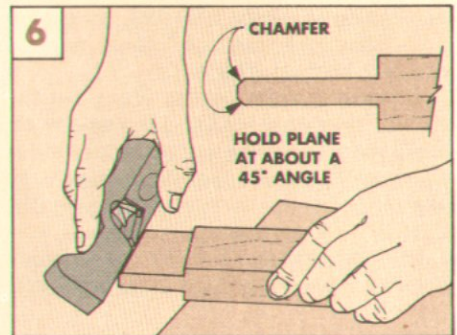

● To help the tenon slide more easily into the mortise, chamfer the ends of the tenon. The low angle cutter on a shoulder plane makes quick work of the end grain.

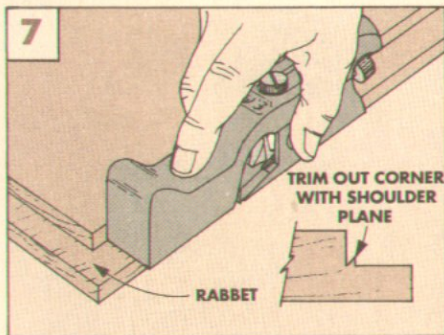

● To smooth the rough bottom or sides of a rabbet cut on a table or radial arm saw, use a long shoulder plane. A shoulder plane can clean out right into the corner.

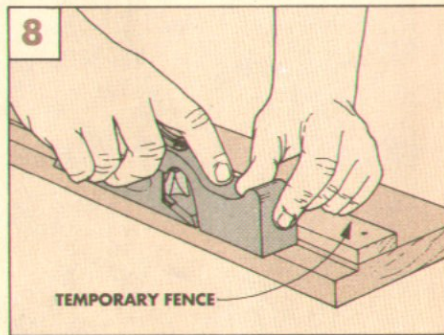

● In addition to trimming, a shoulder plane can be used to cut a rabbet. Tack a fence to the workpiece as a guide. For cross-grain work, first score the edge with a knife.

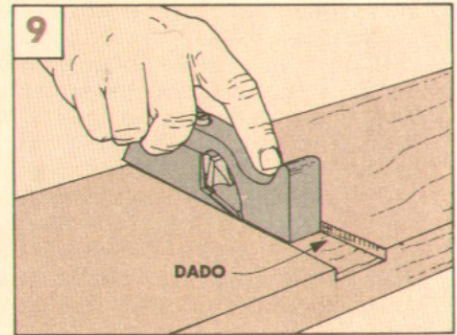

● Cleaning up dados and grooves is much like trimming a rabbet. To do this, use a shoulder plane that's slightly narrower than the dado or groove.

BULLNOSE PLANES

When I'm trimming a rabbet on a small piece of molding or a small box, I don't need or want a long shoulder plane — I reach for a short version of a shoulder plane called a bullnose plane, see Fig. 10. It shares the important features of the shoulder planes (low angle cutter, square sides and bottom). But the nose on a bullnose plane is only ¼" long. This means the plane is lighter and easier to use where space is limited, see Fig. 11.

In fact, a bullnose plane can be used in most situations instead of a longer shoulder plane. But without a long nose in front of the cutting edge, the plane follows the hills and valleys along a rabbet or groove, and can produce an uneven cut. And for squaring tenon shoulders, a longer plane is better.

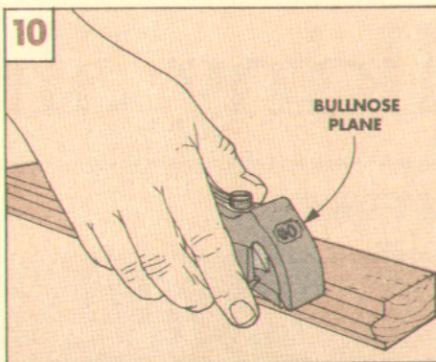

● The bullnose plane is used with one hand. Its short length and light weight make it a logical choice for delicate work.

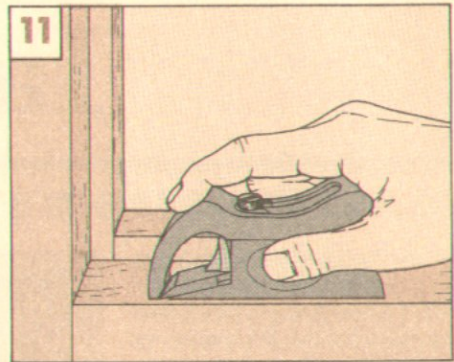

● Lacking the long nose of the shoulder plane, the bullnose plane can be worked very close to an obstruction.

CHISEL PLANES

It isn't often that you need to trim in a spot too tight for a bullnose plane. But when that happens, a chisel plane may be the tool to use. The low angle cutter makes quick work of squaring up an inside corner, see Fig. 12. And, without a nose piece to get in the way, I also use it to trim dovetail joints and the fingers of a box joint, see Fig. 13.

Fortunately, you may not have to buy another plane to do this — many shoulder and bullnose planes convert to chisel planes.

To convert a shoulder plane into a chisel plane, it's just a matter of removing the nose piece. What's left is the housing for the blade and the blade adjustment mechanism. Chisel planes aren't comfortable to hold, but this sort of trimming doesn't take too long.

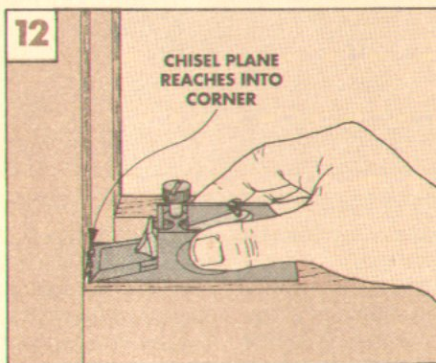

● A chisel plane can trim all the way into a corner. To keep the bottom square to the sides, hold the plane against side of rabbet.

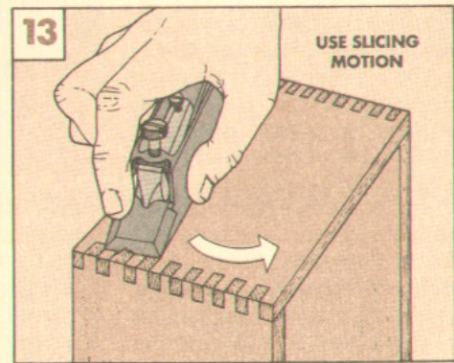

● To pare down the protruding ends of a box or dovetail joint, move the cutting edge from side to side in a slicing motion.

SELECTING A PLANE

The first shoulder plane I bought was a Record No. 311, a "three-in-one" plane. Since I really didn't know just how I was going to use it, the No. 311 was a good choice. With its interchangeable nose pieces, it can be used as a 6½"-long shoulder plane, a 4" bullnose plane, and a chisel plane.

WHAT WOULD I DO TODAY? If I were starting over, I'd do things differently. As good as the No. 311 is, it's expensive — about \$140. Also you have to change parts to change functions, and risk losing parts.

What I'd do instead is get two shoulder planes, the Stanley No. 90 and 93. At roughly \$55 and \$75, they're not cheap. But they're less expensive than the No. 311 and similar shoulder planes made by Record or Clifton.

If I were only going to get one, I'd get the No. 90 bullnose first. It can do everything the larger No. 93 can do, but it doesn't have the long nose. I'd add the No. 93 when I could

afford it, so it would be easier to trim long rabbets flat and true. Also, it's best to use a long plane when trimming tenon shoulders.

ADD ANOTHER LATER. If someday your budget allows it, I'd recommend adding a third plane, the Stanley No. 92 (about \$60). This shoulder plane is ¼" narrower and 1" shorter than the No. 93. It's helpful when cleaning up narrow grooves and dadoes, and smaller tenons.

All these planes have adjustable mouth openings. And they convert to chisel planes. So with these, you can do just about anything you'll need from a shoulder plane.

STANLEY. This series of shoulder planes (originally there was a larger No. 94, too) were first designed and manufactured in America by Stanley around the turn of the century. But now, like the Record and Clifton planes, they're made in England. These planes are nickel plated to help prevent rust.

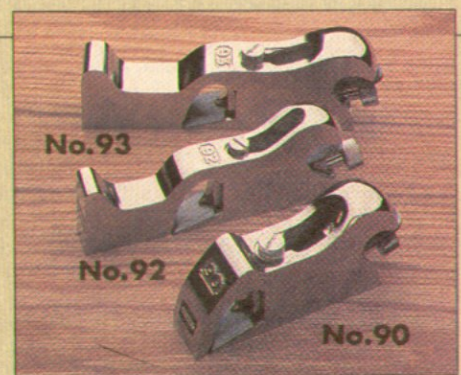

This makes them look somewhat different than the Record and Clifton planes, but under the skin, they're all the same.

WHERE CAN YOU GET THEM? I doubt you'll find these planes at a local hardware store. But they're readily available through tool catalogs (see Mail Order Sources on page 31) and at many woodworking stores.

Talking Shop

PLANE NUMBERING SYSTEMS

■ I was at an auction the other day and came across some nice, older hand planes. When they came up for bid, the auctioneer referred to them by number (such as a No. 5 and a No. 60½.) What do these numbers mean?

Nathan C. Serpico
Beech Grove, Indiana

The numbers identify the type of plane, its size, and the blade width. Manufacturers of planes stamp or cast numbers in the bodies of planes for identification.

Over the years, some plane manufacturers set up their own numbering system. But many use the same numbering system established a long time ago.

For example, in the article on shoulder planes (see page 22), we're showing planes from different manufacturers that are almost identical in size, type, and blade width — and all have the same number.

A SYSTEM. This made me wonder. How did all those different companies decide on the same numbering system? Did they convene a committee and debate the pros and cons of different numbering systems?

To help unravel this mystery, I called Fred Curry, a retired Educational Marketing Consultant for Stanley Tools and renowned Stanley tool authority.

Fred explained that "because of their success, Stanley's numbering system became the standard. Other tool makers

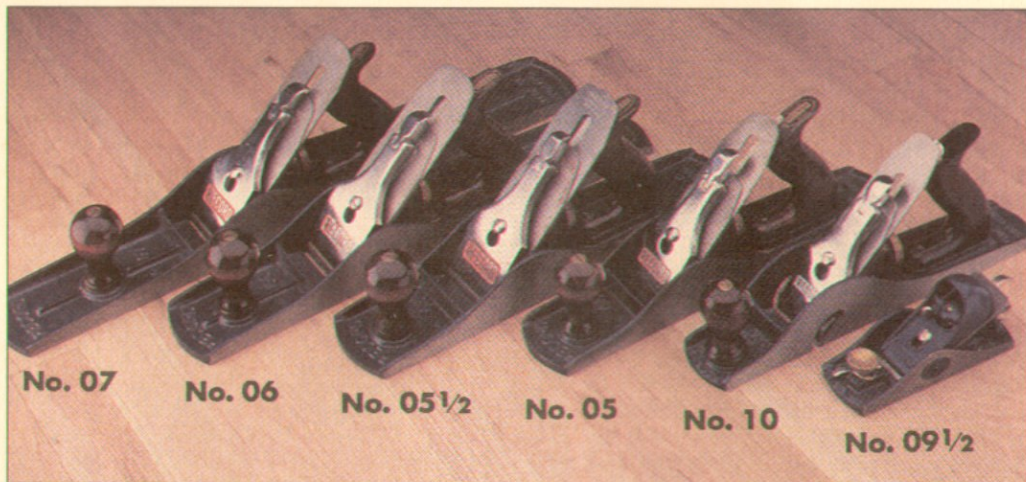

simply wanted to identify with Stanley, and gain recognition by using their numbers."

It helps to know most planes are numbered following Stanley's system, but even it can be confusing. Fortunately, there are a few patterns that emerge.

PATTERNS. Numbering of the metal planes from No. 1 to No. 8 follow a general rule of thumb. The larger the number, the longer the plane, and the wider the blade.

The wood-bottom "transition" planes from No. 21 to 37 follow a similar pattern. (These planes bridged the gap between wooden and metal planes — they maintained a wooden sole, but offered the convenience of a metal plane's adjustments.)

This same numbering system

is used for the combination planes starting at No. 41, the router planes starting at No. 71, and the inexpensive block planes starting at No. 101.

Then things get sort of confusing. Between each of these a variety of special planes were assigned numbers. So a core box plane is numbered No. 57.

INCREMENTS. Another numbering practice was to add increments of one hundred to the basic numbers. This was used for planes that had a similar function, but a different design.

For example, the difference between the No. 22 and 122 wood-bottom planes is the way the cutter is adjusted edgewise. One uses a screw and the other uses a lever.

But this is more often the exception than the rule. An example of this would be the No. 105 and the No. 205 planes. The No. 105 is a 14" jack plane with a 2½"-wide blade. The No. 205 is a 6¼" block plane with a 1½"-wide blade — quite a difference.

LETTERS. On the off-chance that someone was able to decipher this relatively complex numbering system, Stanley also used letters to confuse matters further. The letters were used to differentiate between similar

products. Some of the letters were A, G, and H. The A identifies the plane as aluminum. The G indicates that this is a Gage plane, a different line of planes. And H stands for Handyman, a less expensive line of tools.

The most commonly used letter is C. Any numbered plane followed by a C indicates that the plane has a corrugated bottom (such as a No. 5C).

If this wasn't confusing enough, the letter P was added in recent years after some numbers to identify the product as a plane — not a rule, level, or some other Stanley product with the same number.

PROBLEM? QUESTION?

Solving a problem (or avoiding one in the first place) is part of every project. But the best solutions aren't always obvious — they often come from one who's faced the problem before.

If you have a problem, solution, question, or even a gripe, maybe we (or another reader) can help. Just write to *Woodsmith*, Talking Shop, 2200 Grand Avenue, Des Moines, Iowa 50312.



Manufacturers of iron planes often cast the identifying number of the plane into its body.



On wood-bottom planes, the number is usually stamped on one end of the wooden body.

CARPET TAPE

■ *I've been using cloth-backed double-sided carpet tape to temporarily fasten templates to a workpiece before routing. But sometimes the template shifts on the workpiece as I rout. Am I using the wrong kind of tape?*

Michael Saunders
Pekin, Illinois

There are three types of carpet tape commonly available: plastic, cloth, and fiberglass, see page 31 for sources. We use cloth carpet tape in the Woodsmith shop to temporarily fasten templates in place, and to hold parts together during assembly.

PLASTIC TAPE. Plastic carpet tape creates a strong bond—but the surfaces to be joined have to be very smooth.

CLOTH TAPE. Since templates are usually fastened to a workpiece that isn't smooth (unsanded), I use cloth carpet tape. It's also easier to reposition a workpiece if you use cloth tape.

TURNERS TAPE. There's also a special cloth tape referred to as "turners" tape. It's used to temporarily hold wood to a lathe faceplate for turning. But it's so strong, you can pull out wood fibers when separating the parts.

FIBERGLASS TAPE. Fiberglass carpet tape is also known as outdoor tape. It's moisture and mildew resistant. But the adhesive is very strong and also has a tendency to tear out wood fibers.

APPLICATION. The tricky part to carpet tape is deciding on how much to use. Too much, and you may not get the parts separated without damage. Not enough, and the parts can slip or come loose and cause an accident.

As a general rule, I use a 3" strip of tape every 6" to 8". If I'm working with a large template, I run strips around the perimeter

and also make a X in the center.

TAPE TIPS. First, make sure both surfaces are clean and dry. After you've taped the parts together, apply sufficient pressure to create a strong bond. To do this, tap the parts with a soft-faced hammer or apply a clamp directly to the tape joint for a few seconds, then remove it.

SEPARATING PARTS. What if the tape holds so well the parts can't be pulled apart? To separate them, flow a little lacquer thinner down the joint. The solvent dissolves the adhesive and the pieces will come apart easily.

ROUTER BIT MAINTENANCE

■ *I recently invested in a set of good carbide-tipped router bits. Besides sharpening, what else can I do to keep these bits in top condition?*

Paul Garvin
Ames, Iowa

The best way to prolong the life of a router bit is to keep it clean. Keeping a bit clean depends on the type of router bit.

NO BEARINGS. To clean bits without bearings, first blow off any dust. Then, remove any resin that has built up. (Resin places a drag on the bit which can cause it to overheat and burn.) Fortunately, resin removers are commonly available, see Mail Order Sources, page 31.

BITS WITH BEARINGS. To clean bits with bearings, first remove the bearing. Then clean as you did with non-bearing bits.

Even though router bearings are "sealed," resin remover can sneak in and dissolve the bearing grease. If this were to happen, you would be faced with the problem of trying to lubricate a sealed bearing.

BEARING LUBRICANTS. What about those special bearing lubricants featured in woodwork-

ing supply catalogs? "I don't use them," explains Brad Witt, a professional woodworker and owner of Woodhaven.

"If all the grease in a bearing has been removed by cleaning, I put a few drops of machine oil (like 3-in-1) on the bearing as a temporary solution. Then I spin the bit before using it to keep oil off the workpiece."

Brad also indicated that "oiling a bearing that doesn't have grease isn't the final solution—what you need to do is replace the bearing. Oil is no substitute for the original-grease packed in the bearings."

This is also the case for bearings that don't spin or spin rough—they're worn out and should be replaced. Fortunately,

replacing a bearing is easy, and relatively inexpensive.

BIT SHANKS. One final note. Periodically inspect the shanks

of your router bits for rust or burrs. Either of these can be removed quickly with steel wool or a Scotch-Brite pad.

STATEMENT OF OWNERSHIP, MANAGEMENT AND CIRCULATION (Required by 39 U.S.C. 3685)

1. Title of Publication: Woodsmith. 1a. Publication No.: 0164-4114. 2. Date of Filing: September 18, 1991. 3. Frequency of issue: Bimonthly. 3a. No. of issues published annually: 6 (six). 3b. Annual subscription price: \$17.95. 4. Complete mailing address of known office of publication: 2200 Grand Avenue, Des Moines, (Polk County), Iowa 50312-5306. 5. Complete mailing address of the headquarters of general business offices of the publisher: 2200 Grand Avenue, Des Moines, Iowa 50312-5306. 6. Full names and complete mailing address of publisher, editor, and managing editor: Publisher and Editor: Donald B. Peschke, 2200 Grand Avenue, Des Moines, Iowa 50312; Managing Editor: Douglas L. Hicks, 2200 Grand Avenue, Des Moines, Iowa 50312. 7. Owner: Woodsmith Corporation, 2200 Grand Avenue, Des Moines, Iowa 50312; Donald B. Peschke, 2200 Grand Avenue, Des Moines, Iowa 50312. 8. Known bondholders, mortgagees, and other security holders owning 1 percent or more of total amount of bonds, mortgages or other securities: None. 9. (Does not apply.) 10. Extent and nature of circulation:

	Average no. copies each issue during preceding 12 months	Average no. copies of single issue published nearest to filing date
A. Total no. copies printed (net press run)	372,500	400,000
B. Paid and/or requested circulation:		
1. Sales through dealers, street vendors and counter sales	6,681	14,185
2. Mail subscriptions (paid and/or requested)	345,656	379,658
C. Total paid and/or requested circulation	352,337	393,843
D. Free distribution by mail, carrier or other means, samples, complimentary, and other free copies	0	0
E. Total distribution	352,337	393,843
F. Copies not distributed:		
1. Office use, left over, unaccounted, spoiled after printing	19,718	6,157
2. Returns from news agents	445	0
G. Total	372,500	400,000
11. I certify that the statements made by me above are correct and complete. (signed) Donald B. Peschke, Publisher/Editor		

Desk Clock

*Evenly-spaced saw kerfs create the stairs and roof dentil.
And under the columns is a hidden compartment that's large
enough to hold business cards or other small supplies.*

I designed this Desk Clock to serve two functions, and the main one is obvious. But you may not notice that, in addition to keeping time, the clock tower stands guard over a small storage compartment.

When you lift the top section of the clock off the stair-stepped base, there's a hidden recess that holds business cards or other small items like coins and paper clips, see photo on page 32.

For sources of the mini-quartz clockworks and fluted dowels, refer to page 31.

MATERIALS

A	Front/Back Stairs (2)	$\frac{3}{4} \times \frac{1}{2} - 5\frac{1}{4}$
B	Side Stairs (2)	$\frac{3}{4} \times \frac{1}{2} - 3\frac{1}{8}$
C	Base Bottom (1)*	$\frac{1}{8} \times 2\frac{1}{4} - 4\frac{1}{2}$
D	Colonnade Btm. (1)	$\frac{1}{4} \times 2\frac{1}{4} - 4\frac{1}{2}$
E	Colonnade Tops (2)	$\frac{1}{4} \times 2\frac{1}{4} - 1\frac{1}{8}$
F	Columns (12)	$\frac{5}{16}$ Dia. - $2\frac{3}{8}$
G	Roof (1)	$1\frac{1}{2} \times 2\frac{5}{8} - 4\frac{7}{8}$
H	Front Tower (1)	$\frac{3}{4} \times 2 - 3\frac{1}{4}$
I	Back Tower (1)	$\frac{3}{4} \times 2 - 3\frac{1}{4}$
* Bottom cut from $\frac{1}{8}$ "-thick Masonite		
• (1) Quartz Clockworks - $1\frac{7}{16}$ " O.D.		



STAIR-STEPPED BASE

I began building the desk clock from the ground up with the stair-stepped base made from two blocks of cherry. But in order to create a storage compartment inside, I made the stair-stepped base as a frame with a bottom panel of Masonite.

CUT BLANKS. To make the stair-stepped base, begin with two blanks, each $2\frac{1}{2}$ " wide and 12" long, see Fig. 1. Shop Note: Starting with a long, wide blank is safer and easier than working with a short, narrow piece.

STEPS. The steps are made by cutting repetitive rabbets over a saw blade. After the first step is cut, the blade is lowered and the fence is moved for the next step.

To cut the steps flat, I used a rip blade because of the blade's flat-top profile, see Fig. 2. Since the steps are only $\frac{1}{16}$ " wide, part of the blade must be "buried" in an auxiliary fence before cutting any of the steps. To do this, lower the blade below the surface of the table. Then set the rip fence $\frac{1}{16}$ " from the

outside edge of the saw blade. Now turn on the table saw and slowly raise the saw blade to $\frac{5}{8}$ ", see Fig. 2.

With the top face of the workpiece down on the table, make one pass on the outside edge of each blank to cut the first step.

To make the second step, first move the fence $\frac{1}{8}$ " from the outside of the saw blade and lower the blade $\frac{1}{8}$ ", see Fig. 3.

Continue moving the fence and lowering the blade until all five $\frac{1}{16}$ "-wide steps are cut.

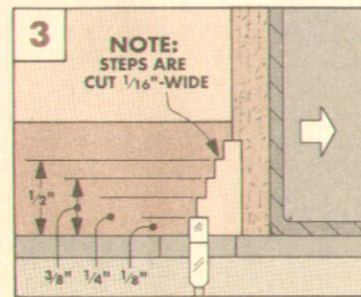
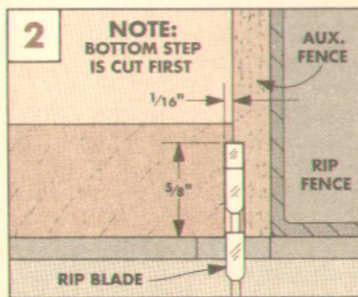
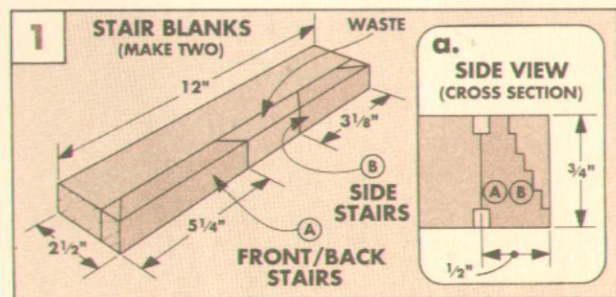

BASE ASSEMBLY

After the steps are cut, the next thing to do is cut a pair of grooves which will later become a pair of rabbets. The bottom rabbets are for the bottom panel, see Fig. 6. And the top rabbets contain the colonnade bottom, refer to Fig. 12a on the next page.

CUT GROOVES. To cut the grooves, first set the rip fence $7/16"$ from the *inside* edge of the saw blade and adjust the blade so it's $1/8"$ high. Then cut a groove on both faces of each blank, see Fig. 4.

RIP TO WIDTH. Next, to form the rabbets and rip the pieces to final width, position the rip fence $1/2"$ away from the blade and raise the blade. Then trim off the waste, see Fig. 5.

CUT MITERS. Now these two narrow pieces can be mitered to length. To do this, first cut a miter on both ends of each blank, refer to Fig. 1. Then cut a second miter to produce a **front/back stairs (A)**. The last miter cut on each piece produces the **side stairs (B)**.

ASSEMBLY. To form a frame, glue the four stair sections together, see Fig. 6. Then, cut a **bottom (C)** from $1/8"$ Masonite to fit the bottom rabbets, and glue it in place.

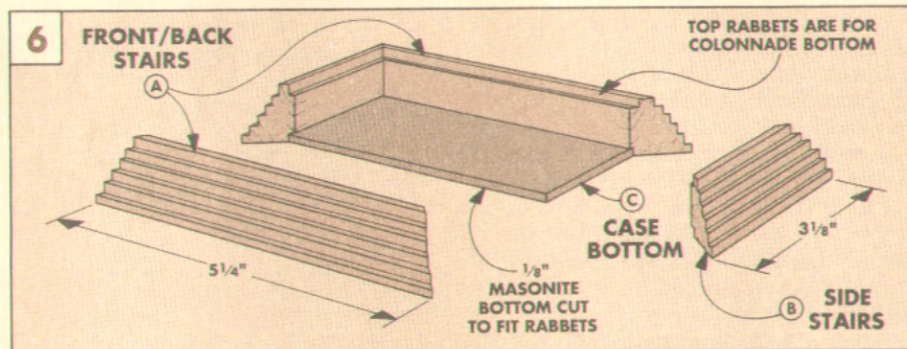
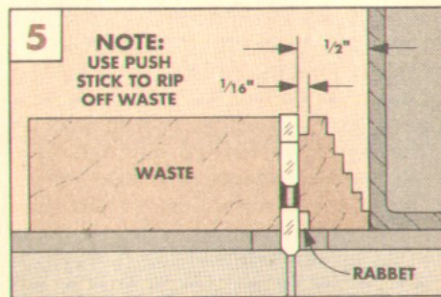
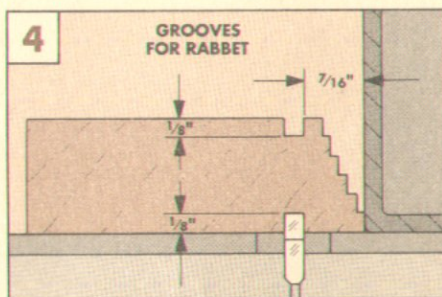

COLONNADE

Now, work can begin on the colonnade. The colonnade consists of a walnut bottom and two-piece top. The top pieces are each supported by six columns. Though you could use standard dowels for the columns, I used fluted dowels — they look more authentic.

TOP AND BOTTOM. Begin work on the colonnade by cutting the $1/4"$ -thick **bottom (D)** and blank for the **tops (E)** to the same size, see Fig. 7. Cut these so the bottom will fit inside the rabbet that runs along the top edge of the base, refer to Fig. 6. The top blank will be cut apart later to produce two separate pieces.

HOLES FOR COLUMNS. Now, tape both walnut pieces together with double-sided carpet tape, see Fig. 7. Then lay out the holes on both ends of the top piece for the dowels.

After the hole positions are laid out, bore a hole at each mark for the columns. (I used a $5/16"$ bit to match the $5/16"$ fluted dowels.) Note: The holes go *through* the colonnade top, but *only* $1/8"$ deep into the colonnade bottom, see Fig. 7a.

Next, mark the orientation of the pieces for reference and separate the two boards. Then cut the top blank to produce the two $1 1/8"$ -wide colonnade tops (E), see Fig. 7.

ASSEMBLY. Once the twelve $2 3/8"$ -long **columns (F)** are cut to length, the colonnade can be assembled, see Fig. 8. Put a drop of glue in each hole in the colonnade bottom. Then insert one column into each hole.

Next, place the colonnade tops onto their respective set of columns and push each one down until it's flush with the column tops.

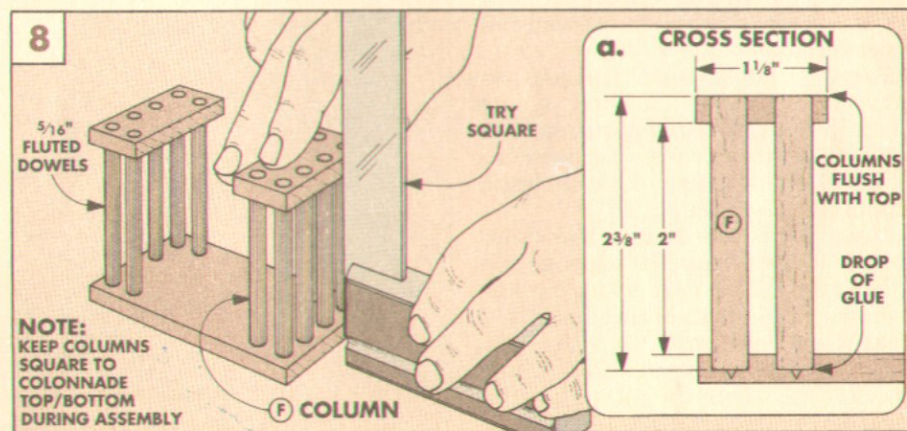
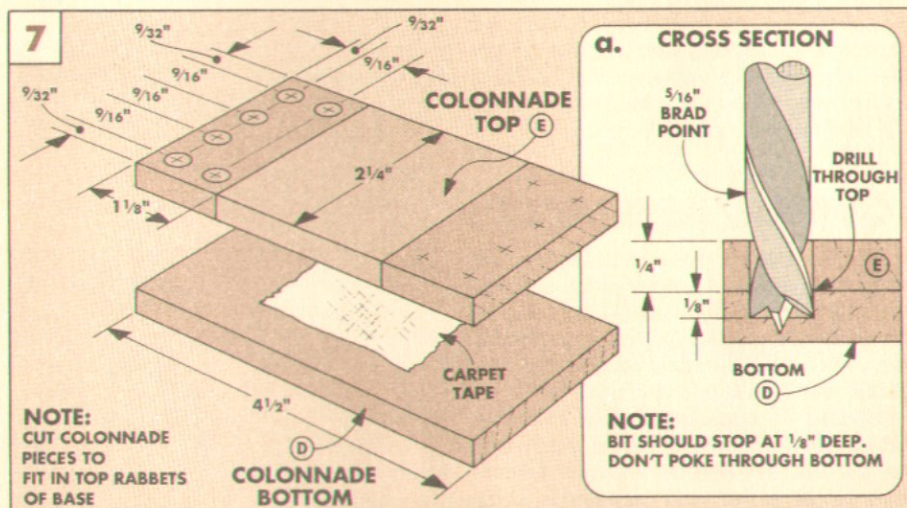

ROOF

The colonnade is covered by a roof that's cut from a single block of $1\frac{1}{2}$ "-thick maple.

DENTIL BLOCKS. To build the roof (G), first cut a block of wood to finished width and length, see Fig. 10. Then to form dentil on the bottom of the block, I cut a number of kerfs, see Fig. 9. (I used a rip blade here.)

To minimize chipout, I cut the first series of kerfs *across* the grain. Then I came back and cut *with* the grain, see Fig. 9. Note: The last cut I made was the $\frac{1}{16}$ " rabbet around the border of the block, see Fig. 9b.

ARCH. The next step is to cut the arch that shelters the two clock towers. First, lay out a semicircle on the side of the roof, see Fig. 10. Center the semicircle on the length of the roof block so it produces a dentil on each side that's the same width as the saw-kerf dentils. (My semicircle has a 1" radius.)

I used the band saw to cut the arch to within $\frac{1}{16}$ " of the pencil mark. (You could use a 2" Forstner bit instead.) Then I sanded up to the pencil mark with a drum sander mounted in the drill press.

After the arch is complete, band saw the top corners off the block to create the sloping sides. Then sand the entire roof piece smooth, see Fig. 11.

ROOF ASSEMBLY. Attach the roof by spreading glue across the top of both colonnade tops (E), making sure to cover the exposed ends of the columns, see Fig. 12. Then center the roof over the colonnade and hold it in place until the glue sets.

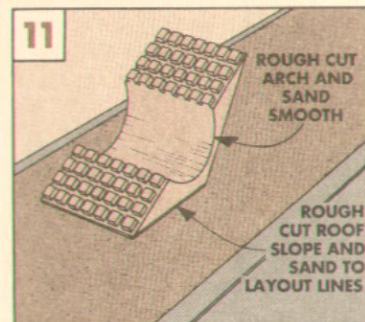
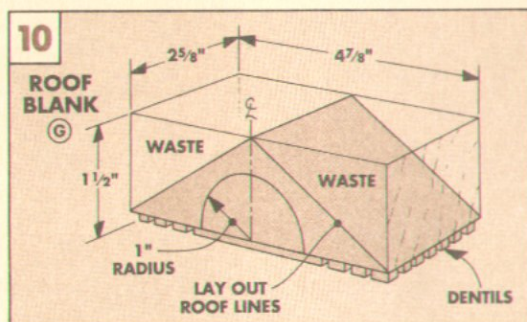
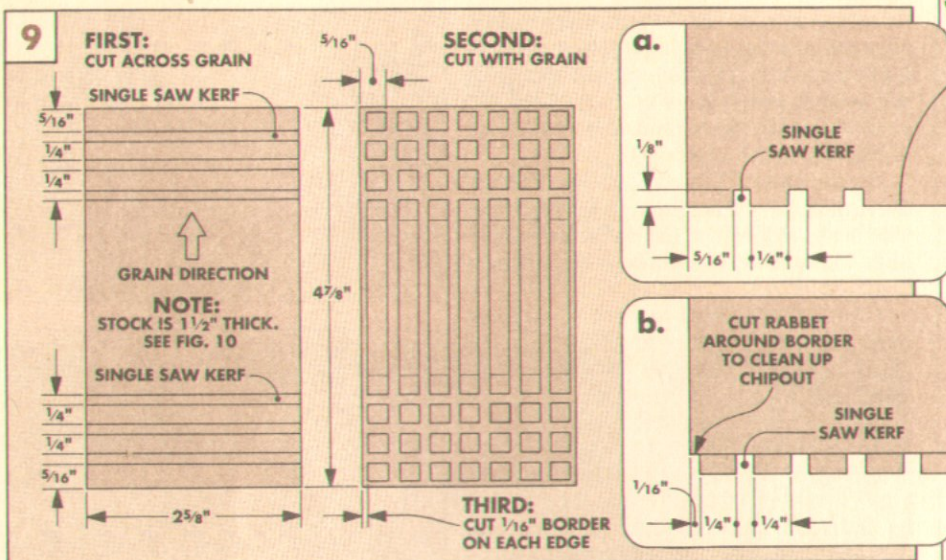

TOWERS/ASSEMBLY

At this point you've completed an open-air pavilion. To make it a desk clock, a **front tower (H)** and **back tower (I)** are needed. I made the towers from $\frac{3}{4}$ "-thick cherry and bored out the front tower to accept the clockworks, see Fig. 12.

TOWERS. To make sure each tower fits tight inside the curved arch, I cut the towers one at a time. For each tower, trace the curvature of the arch on a 2"-wide blank. Then cut the arched top on one end of each blank, and cut off the other end so the tower fits under the roof.

Shop Note: For the best fit, it may be necessary to lightly sand the curve of each tower. Then, to conceal any minor irregularities in the joint line between the tower and the arch, I slightly softened the front outside edge of each tower, see Fig. 12.

CLOCKWORKS AND FINISH. The clockworks is friction fit into a $1\frac{3}{8}$ "-diameter hole in the front tower (H). After drilling the hole, I sprayed on two coats of Deft Semi-Gloss Clear Wood Finish on all the parts. Then, install the clockworks and screw the two towers in place. Each tower is set back $\frac{1}{4}$ " under the roof, see Fig. 12a.

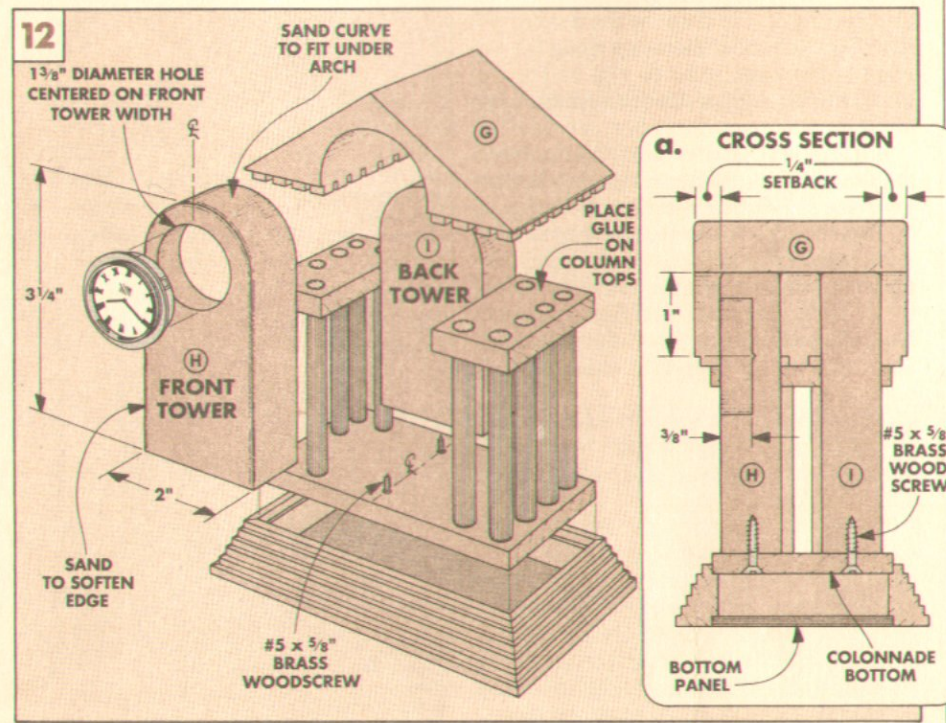

Sources

PEDESTAL DESK

Woodsmith Project Supplies is offering a hardware kit for the Pedestal Desk shown on page 6. (Note: Since you may want to make your own drawer pulls or buy a different style pull, the kit does *not* include pulls. But we're offering the pulls shown on page 6 separately, see below.)

The vanity panel for the desk is an option you may or may not want to build, see page 13. If you decide to add this, you will need threaded inserts and screws. These are not part of the Hardware Kit, but can be ordered separately, see next column.

We're also offering separately packages of letter size hanging file folders to fit in the file drawer, see next column.

Pedestal Desk

779-100 Pedestal Desk Hardware Kit\$39.95

- (1 pair) Accuride Full Extension Drawer Slides, 24" Long, Load Rated to 110 lbs., with Mounting Instructions
- (28 feet) Nylon Glide Strip, 1/2" Wide, Self-Adhesive
- (8) Desk Top Fasteners, Countersunk Holes, Supplied with No. 8 x 3/4" Flathead Screws
- (4) 1/4" Carriage Bolts, Nuts, and Washers

Drawer Pulls

1005-225 Red Oak Drawer Pulls, 1 3/8" High, 6 1/4" Long, With 1 1/4" Screws.....\$3.25 each

Vanity Panel Hardware

779-150 Pedestal Desk Vanity Panel Hardware.....\$1.95

- (4) 1/4" Threaded Inserts
- (4) 1/4" x 1 1/4" Roundhead Machine Screws and Washers

Hanging Files

1101-150 Hanging Files, Letter Size, Package of 25, Includes Label Tabs.....\$10.95 pkg.

Full Extension Slides

Though one pair of Accuride 24" Full Extension Drawer Slides is included in the Pedestal Desk Hardware Kit described at left, you may want to build a file drawer on both sides of your desk. In that case, you will need to order an extra pair of these high quality slides.

1006-120 24" Accuride Full Extension Slides.....\$27.95 pair

DESK CLOCK

Woodsmith Project Supplies is offering a hardware kit to build the Desk Clock shown on page 28. (Note: This kit does *not* include the wood, except the dowels.) We're also offering a 1 3/8"-dia. Forstner bit to drill the hole for the clockworks.

Desk Clock Hardware

779-200 Desk Clock Hardware Kit\$18.95

- (1) Mini-Quartz Clockworks, White Face, Roman Numerals, 1 7/16" Outside Diameter, Requires 1 3/8"-Dia. Hole, 3/8" Deep
- (4) Fluted Hardwood Dowels, 5/16" Diameter x 8 1/8" Long

(You'll need to cut each of these into three 2 3/8"-long pieces to produce the twelve columns for the clock.)

- (2) No. 5 x 5/8" Fh. Screws

Forstner Bit

1505-315 1 3/8"-Dia. Forstner Drill Bit\$19.95

JIG KITS

It's easiest to use jigs to cut the dovetails for the drawers on the Pedestal Desk and the box joints on the In/Out Desk Box. **Woodsmith Project Supplies** offers hardware kits to build these two jigs. The instructions for building and using these jigs are included in previous issues of *Woodsmith*. (Dovetail Jig: No. 58; Box Joint Jig: No. 78)

Dovetail Jig Kits

758-310 Dovetail Jig Hardware Kit. (Includes *Woodsmith* No. 58. Does *not* include any wood.)\$38.95

758-330 Dovetail Jig Hardware and Wood Kit. (Includes *Woodsmith* No. 58 and maple blanks to build jig.)\$59.95

1514-550 1/2", 14" Dovetail Router Bit, Carbide-Tipped (1/4" shank)\$15.95

Box Joint Jig

778-300 Box Joint Jig Hardware Kit (Includes hardware but *not* wood. For instructions on building the jig, order *Woodsmith* No. 78 below)\$8.95

702-078 *Woodsmith* Issue No. 78\$3.95

ROUTER BITS

Woodsmith Project Supplies is offering carbide-tipped bits for the projects in this issue. Order the shank size to fit your router.

Router Bits

1514-355 1/4" Roman Ogee Bit (1/4" shank)\$31.95

1512-375 1/4" Roman Ogee Bit (1/2" shank)\$33.95

1514-116 1/2" Cove Bit (1/4" shank)\$30.95

1512-118 1/2" Cove Bit (1/2" shank)\$32.95

1514-885 1/2" Flush Trim Bit (1/4" shank)\$15.95

1512-887 1/2" Flush Trim Bit (1/2" shank)\$17.95

1514-819 1/2" Round-Over Bit (1/4" shank)\$26.95

1512-828 1/2" Round-Over Bit (1/2" shank)\$28.95

1512-685 3/4" Straight Bit (1/2" shank)\$16.95

CARPET TAPE

On page 27, we talked about different kinds of double-sided tape. **Woodsmith Project Supplies** is offering the carpet tape we use in the *Woodsmith* shop.

Cloth Carpet Tape

4110-112 Carpet Tape, 1 1/2"-Wide, 42 ft.-Long Roll\$7.95

SHOULDER PLANES

The shoulder planes described on pages 22 to 25 are available from a number of mail order sources, see below.

ORDER INFORMATION

BY MAIL

To order by mail, use the form enclosed with a current issue. The order form includes information on handling and shipping charges, and sales tax. Send your mail order to:

Woodsmith Project Supplies
P.O. Box 10350
Des Moines, IA 50306

BY PHONE

For fastest service use our Toll Free order line. Open Monday through Friday, 8:00 AM to 5:00 PM Central Time.

Before calling, have your VISA, MasterCard, or Discover Card ready.

1-800-444-7002

Note: Prices subject to change after April, 1991.

MAIL ORDER SOURCES

Similar hardware and supplies may be found in the following catalogs. Please call each company for a catalog or information.

Cherry Tree Toys

800-848-4363
Clockworks, Fluted Dowels, Forstner Bit

Constantine's

800-223-8087
Desk Hardware, Forstner Bit, Shoulder Planes, Carpet Tape

Woodcraft

800-225-1153
Desk Hardware, Forstner Bit, Shoulder Planes, Carpet Tape, Resin Remover

Klockit

800-556-2548
Clockworks

Meisel Hardware

800-441-9870
Nylon Glide Strip, Forstner Bit

Trend-Lines

800-767-9999
Slides, Forstner Bit, Resin Remover

Williams Tool

800-338-6668
Fluted Dowels, Shoulder Planes

Woodhaven

800-344-6657
Router & Bit Maintenance Kit, Bearings

The Woodworkers' Store

612-428-2199
Desk Hardware, Forstner Bit, Resin Remover, Carpet Tape

Woodworker's Supply

800-645-9292
Desk Hardware, Forstner Bit, Resin Remover, Carpet Tape

Final Details

Pedestal Desk

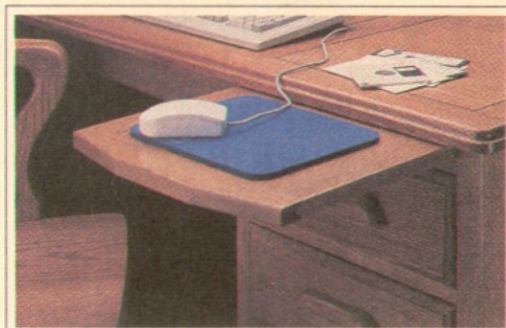

▲ The century-old design of this oak Pedestal Desk is well suited to almost any office or study. A vanity panel between the pedestals gives the desk a formal appearance (photo

above). Or make it without a vanity panel for a more open, graceful look (top photo). A writing slide in each pedestal pulls out for extra working surface (bottom photo).

Desk Clock



▲ Lift the top off this Desk Clock to store small items in the base. The cherry stairs are made with repetitive saw cuts. The roof is a maple block that's kerfed to create a decorative edge.

In/Out Box

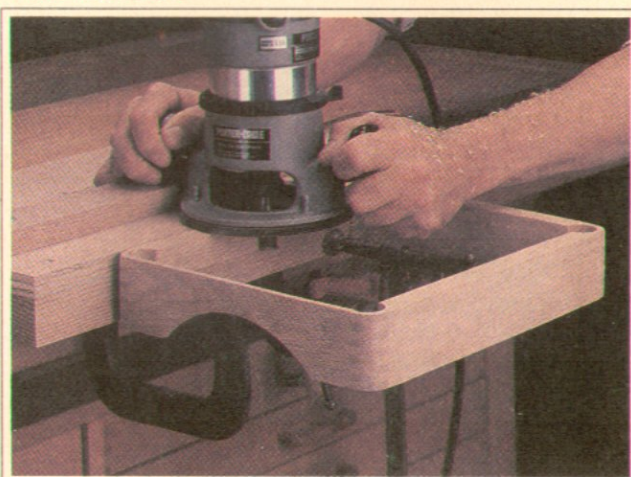

▲ The corners of this In/Out Box are rounded to make the box joints appear to "bend." Then, as shown here, the sides of the box are routed so they match the thickness of the corners.