

POPULAR
Woodworking
MAGAZINE

August 2013 ■ #205

1895 Mantel Clock

Delicate Details Made Simple

Scoop a Seat
Clever Table Saw Jig
Delivers Great Results

**William & Mary
Spice Chest**
Add 300 Years with a
Multi-Layered Finish

**Double-Bevel
Inlay Perfection**
No-Sweat Steps to
Stunning Results

Gent's Mirror
Handsome Features in
A Weekend Project



Carve a Classic Linenfold Panel
Flowing Forms from Planes & Chisels

tw media US \$5.99



0 74470 01355 6 08

Display until August 19, 2013



Grizzly Industrial

PURVEYORS OF FINE MACHINERY®, SINCE 1983!

- OVER A MILLION SQUARE FEET PACKED TO THE RAFTERS WITH MACHINERY & TOOLS
- 2 OVERSEAS QUALITY CONTROL OFFICES STAFFED WITH QUALIFIED GRIZZLY ENGINEERS
- HUGE PARTS FACILITY WITH OVER 1 MILLION PARTS IN STOCK AT ALL TIMES
- 24 HOUR ORDERING BY PHONE OR ONLINE • MOST ORDERS SHIP THE SAME DAY



30TH ANNIVERSARY SPECIAL EDITION 14" DELUXE BANDSAW

- Motor: 1 HP, 110V/220V, single-phase, TEFC
- Precision-ground cast iron table size: 14" sq.
- Table tilt: 45° R, 15° L
- Cutting capacity/throat: 13½"
- Max. cutting height: 6"
- Blade size: 92½"-93½" L (⅞"-¾" W)
- Blade speeds: 1500 & 3200 FPM
- Approx. shipping weight: 205 lbs.

CAST IRON WHEELS

MADE IN TAIWAN

Available in June

G0555LANV
INTRODUCTORY PRICE
REG. \$545⁰⁰ **\$445⁰⁰**



30TH ANNIVERSARY SPECIAL EDITION 17" BANDSAW

- Motor: 2 HP, 110V/220V, single-phase, TEFC
- Precision-ground cast iron table size: 17" sq.
- Table tilt: 45° R, 10° L
- Cutting capacity/throat: 16½"
- Max. cutting height: 12½"
- Blade size: 131½" L (⅞"-1" W)
- Blade speeds: 1700 & 3500 FPM
- Quick release blade tension lever
- Approx. shipping weight: 342 lbs.

INCLUDES DELUXE EXTRUDED ALUMINUM FENCE, MITER GAUGE & ½" BLADE

MADE IN TAIWAN

G0513ANV
INTRODUCTORY PRICE
REG. \$895⁰⁰ **\$795⁰⁰**



10" LEFT-TILTING CONTRACTOR-STYLE TABLE SAW with Riving Knife

- Motor: 1½ HP, 110V/220V, single-phase
- Precision-ground cast iron table with wings
- Table size: 25¼" x 40" • Arbor: ⅝"
- Arbor speed: 4000 RPM
- Capacity: 3⅝" @ 90°, 2¼" @ 45°
- Rip capacity: 30" R, 12" L
- Approx. shipping weight: 221 lbs.

MADE IN TAIWAN



FREE 10" CARBIDE-TIPPED BLADE



MADE IN ISO 9001 FACTORY!

G0732 \$795⁰⁰ SALE **\$695⁰⁰**



10" HYBRID TABLE SAW with Riving Knife

- Motor: 2 HP, 110V/220V, single-phase
- Precision-ground cast iron table with wings measures 27" x 40" • Arbor: ⅝" • Arbor speed: 3850 RPM • Capacity: 3⅝" @ 90°, 2⅝" @ 45° • Rip capacity: 30" R, 12" L • Quick change riving knife • Cast iron trunnions • Approx. shipping weight: 404 lbs.



INCLUDES BOTH REGULAR & DADO BLADE INSERTS

G0715P ONLY \$795⁰⁰

BEAUTIFUL WHITE COLOR!



10" LEFT-TILTING TABLE SAWS with Riving Knife & Cast Iron Router Table

- Motor: 3 HP or 5 HP, 240V, single-phase
- Precision-ground cast iron table size with wings: 27" x 48"
- Arbor: ⅝"
- Cutting capacity: 25½" R, 8" L
- Max. depth of cut: 3" @ 90°, 2⅝" @ 45°
- Approx. shipping weight: 546 lbs.

MADE IN TAIWAN



G1023RLW 3 HP ONLY \$1350⁰⁰

G1023RLWX 5 HP ONLY \$1395⁰⁰



10" CABINET TABLE SAW with Riving Knife & Extension Rails

- Motor: 3 HP, 220V, single-phase
- Precision-ground cast iron table
- Table size with extension: 27" x 74¾"
- Arbor: ⅝" • Arbor speed: 4300 RPM
- Max. depth of cut: 3⅝" @ 90°, 2⅝" @ 45°
- Max. rip capacity: 50" • Max. dado width: 1⅞"
- Approx. shipping weight: 572 lbs.

FREE 10" CARBIDE-TIPPED BLADE

See our website for **Reviews & Awards** grizzly.com



3 HP LEESON® MOTOR!



G0691 \$1425⁰⁰ SALE **\$1375⁰⁰**



ULTIMATE 14" BANDSAW

- Motor: 1 HP, 110V/220V, single-phase, TEFC
- Precision-ground cast iron table size: 14" sq.
- Table tilt: 45° R, 15° L
- Cutting capacity/throat: 13½"
- Max. cutting height: 6"
- Blade size: 92½"-93½" L (⅞"-¾" W)
- Blade speeds: 1500 & 3200 FPM
- Approx. shipping weight: 196 lbs.



MADE IN TAIWAN

See our website for **Reviews & Awards** grizzly.com

G0555P \$525⁰⁰ SALE **\$495⁰⁰**



19" HEAVY-DUTY BANDSAWS

- Motor: 3 HP, 220V, single-phase, TEFC
- Precision-ground cast iron table size: 26¾" x 19"
- Table tilt: 45° R, 5° L
- Cutting capacity/throat: 18¾"
- Max. cutting height: 12"
- Blade size: 143" L (⅞"-1¼" W)
- Blade speeds: 1700 & 3500 FPM
- Approx. shipping weight: 460 lbs.

EXTREME SERIES

DELUXE RE-SAW FENCE INCLUDED

MADE IN TAIWAN



G0514X \$1495⁰⁰ SALE **\$1395⁰⁰**

ALSO AVAILABLE **G0514XF** W/ FOOT BRAKE ONLY \$1395⁰⁰



15649

PRICING CODE
13POP
MENTION THIS CODE WHEN PLACING YOUR ORDER

1-800-523-4777

3 GREAT SHOWROOMS! BELLINGHAM, WA • MUNCY, PA • SPRINGFIELD, MO

TECHNICAL SERVICE:
570-546-9663
FAX: 800-438-5901

Summer Sale

Starts April 1st - Ends September 21st

PLEASE GO TO GRIZZLY.COM® TO SEE ALL SALE PRICES



FREE CATALOG

764 PAGES OF HIGH QUALITY TOOLS AND MACHINERY AT INCREDIBLE PRICES

12" JOINTER/PLANER COMBINATION MACHINES

- Motor: 5 HP, 220V, single-phase
- Jointer table size: 14" x 59 1/2"
- Cutterhead dia.: 3 3/8"
- Cutterhead speed: 5034 RPM
- Max. jointer depth of cut: 1/8"
- Max. width of cut: 12"
- Planer feed rate: 22 FPM
- Max. planer depth of cut: 1/8"
- Max. planer cutting height: 8"
- Planer table size: 12 1/4" x 23 1/4"
- Approx. shipping weight: 734 lbs.

CARBIDE INSERT SPIRAL CUTTERHEAD!

MADE IN TAIWAN



NEW END-MOUNTED FENCE

See our website for Reviews & Awards grizzly.com



G0634XP ONLY \$2295⁰⁰

ALSO AVAILABLE IN GRIZZLY GREEN

G0633 JOINTER/PLANER ONLY \$1995⁰⁰

G0634Z SPIRAL CUTTERHEAD MODEL ONLY \$2595⁰⁰



CYCLONE DUST COLLECTOR

- Motor: 1 1/2 HP, 110V/220V, single-phase, TEFC, 3450 RPM
- Air suction capacity: 775 CFM
- Static pressure at rated CFM: 1.08"
- Intake port: 6" with included 5" optional port
- Impeller: 13 1/2"
- Height: 65 1/2"
- Built-in remote control switch
- Approx. shipping weight: 210 lbs.



MADE IN TAIWAN

ONLY 65 1/2" TALL!

BEAUTIFUL WHITE COLOR!

FULLY MOBILE WITH BUILT-IN CASTERS



PLEATED FILTER IS PROTECTED BY A STEEL CAGE



G0703P ONLY \$795⁰⁰

8" JOINTERS

- Motor: 3 HP, 220V, single-phase, TEFC
- Precision-ground cast iron table size: 9" x 72 1/2"
- Max. depth of cut: 1/8"
- Max. rabbeting depth: 1/2"
- Cutterhead dia.: 3"
- Cutterhead speed: 4800 RPM
- Cuts per minute: 20,000 (G0656P), 21,400 (G0656PX)
- Approx. shipping weight: 500 lbs.

CHOOSE EITHER 4 HSS KNIVES OR SPIRAL CUTTERHEAD MODEL



FREE SAFETY PUSH BLOCKS

BUILT-IN MOBILE BASE



4 KNIFE CUTTERHEAD **G0656P ONLY \$825⁰⁰**

SPIRAL CUTTERHEAD **G0656PX ONLY \$1225⁰⁰**



12" X 60" SHORT BED JOINTER with Spiral Cutterhead

- Motor: 3 HP, 220V, single-phase, TEFC
- Precision ground cast iron table size: 13" x 60"
- Fence: 5 3/4" x 31 1/4"
- Cutterhead dia.: 3 3/4"
- Cutterhead speed: 4950 RPM
- Bevel jointing: 45°, 90°, 135°
- Max. depth of cut: 1/8"
- Approx. shipping weight: 832 lbs.
- FREE SAFETY PUSH BLOCKS
- MADE IN ISO 9001 FACTORY!

PARALLELOGRAM TABLE ADJUSTMENT



G0706 ONLY \$2495⁰⁰



15" PLANERS

- Motor: 3 HP, 220V, single-phase
- Precision-ground cast iron table size: 15" x 20"
- Min. stock thickness: 3/8"
- Min. stock length: 8"
- Max. cutting depth: 1/8"
- Feed rate: 16 & 30 FPM
- Cutterhead speed: 4800 RPM
- Approx. shipping weight: 660 lbs.

CHOOSE EITHER 3 KNIFE OR SPIRAL CUTTERHEAD MODEL



BUILT-IN MOBILE BASE

G0453P \$1095⁰⁰ SALE \$1050⁰⁰

WITH SPIRAL CUTTERHEAD **G0453PX ONLY \$1695⁰⁰**



18" OPEN END DRUM SANDER

- Sanding motor: 1 1/2 HP, 110V, single-phase, 15A
- Drum surface speed: 4000 FPM
- Conveyor feed rate: Variable, 2-12 FPM
- Max. stock dimensions: 36" W x 4 1/2" H
- Min. board length: 6"
- Min. board thickness: 1/8"
- Sanding drum size: 4"
- 2 1/2" dust collection port
- Overall size: 35" W x 50" H x 24" D
- Approx. shipping weight: 328 lbs.



G0458 \$995⁰⁰ SALE \$850⁰⁰



15" DISC SANDER with Stand

- Motor: 1 1/2 HP, 220V, single-phase, 1720 RPM
- Cast iron sanding disc size: 15"
- Cast iron table size: 12" x 20"
- Table tilt: +15° to -45°
- Floor to table height: 37"
- Dust port: 2 1/2"
- Approx. shipping weight: 232 lbs.

INCLUDES MITER GAUGE

MADE IN TAIWAN



FEATURES BUILT-IN MOTOR BRAKE & STORAGE CABINET WITH SHELF



G0719 \$875⁰⁰ SALE \$825⁰⁰



3 HP DUST COLLECTOR

- Motor: 3 HP, 240V, single-phase, 12A
- Blower/impeller: 12 3/4" balanced cast aluminum
- Airflow capacity: 2320 CFM
- Max. static pressure: 16.9"
- Sound rating: 87dB
- 7" inlet has removable "Y" fitting with three 4" inlets
- Canister filter size (dia. x depth): 19 1/2" x 23 3/8" (2)
- Bag capacity: 11.4 cubic feet
- Overall dimensions: 57 1/2" long x 32" wide x 71" high
- Approx. shipping weight: 232 lbs.
- CSA certified



G0562ZP \$675⁰⁰ SALE \$625⁰⁰



FOLLOW US ON:



grizzly.com®

OVER 15,000 PRODUCTS ONLINE!





Grizzly Industrial

PURVEYORS OF FINE MACHINERY®, SINCE 1983!

- OVER A MILLION SQUARE FEET PACKED TO THE RAFTERS WITH MACHINERY & TOOLS
- 2 OVERSEAS QUALITY CONTROL OFFICES STAFFED WITH QUALIFIED GRIZZLY ENGINEERS
- HUGE PARTS FACILITY WITH OVER 1 MILLION PARTS IN STOCK AT ALL TIMES
- TRAINED SERVICE TECHNICIANS AT ALL 3 LOCATIONS • MOST ORDERS SHIP THE SAME DAY



30th Anniversary

SPECIAL EDITION BANDSAWS INTRODUCTORY PRICES!

In celebration of our 30th Anniversary, we have taken two of our most popular saws and created a special edition color scheme that is sure to be the eye candy in workshops and small businesses nationwide. Both the G0555LANV and the G0513ANV are the exact same machines as our popular G0555LX and G0513 except for our anniversary special edition colors. Grab one quick, these are sure to sell out fast!

FEATURES:

- Deluxe extruded aluminum fence
- 4" dust port
- Deluxe heavy-duty stand
- Includes one 3/8" blade, fence, and miter gauge
- Rack-and-pinion guide post adjustment for upper blade guides
- Cast iron wheels

SPECIFICATIONS:

- Motor: 1 HP, TEFC, 110V/220V, single-phase (prewired 110V)
- Amps: 11 at 110V, 5.5 at 220V
- Cutting capacity/throat: 13 1/2"
- Max. cutting height: 6"
- Footprint: 23 1/2" x 16 1/2"
- Table height above floor: 43"
- Table tilt: 45° right, 10° left
- Frame construction: cast iron
- 2 blade speeds: 1800 & 3100 FPM
- Blade size: 93 1/2" long
- Precision-ground cast iron table
- Blade width range: 1/8" - 3/4" wide
- Table size: 14" x 14"
- Sturdy T-shape fence design
- Overall size: 67 1/2" H x 27" W x 30" D
- Approx. shipping weight: 247 lbs.



CAST IRON WHEELS

AVAILABLE JUNE, 2013!

G0555LANV
14" DELUXE BANDSAW
Reg. ~~\$545.00~~ **\$445.00**

MADE IN TAIWAN



G0513ANV
17" BANDSAW
Reg. ~~\$895.00~~ **\$795.00**

MADE IN TAIWAN



PRICING CODE
13POP
MENTION THIS CODE
WHEN PLACING YOUR ORDER
15507



1-800-523-4777 grizzly.com®

3 GREAT SHOWROOMS! BELLINGHAM, WA • MUNCY, PA • SPRINGFIELD, MO
TECHNICAL SERVICE: 570-546-9663 FAX: 800-438-5901

CARD #57 or go to PWFREEINFO.COM

CONTENTS

AUGUST 2013



36



40



47

FEATURES

22 **Voysey Mantel Clock**

Ebony and mother-of-pearl inlay adorn an 1895 design by one of the eminent architects of the British Arts & Crafts movement.

BY ROBERT W. LANG

ONLINE ► **Cut Circles Using Your Drill Press**

Learn how to create thin, circular inlay using segmented sections and a fly-cutter.

popularwoodworking.com/aug13

30 **Carve a Classic Linenfold Panel**

Create the illusion of draped cloth with this step-by-step demonstration of shallow-relief panel carving.

BY MARY MAY

ONLINE ► **A Master Carver at Work**

Watch as the author works on the delicate cloth edge of a linenfold panel.

popularwoodworking.com/aug13

36 **Take a U-turn To Scoop a Chair Seat**

Sculpt the perfect design for your seat using this engineer-approved, simple-to-build, table saw jig; it's quick and safe work.

BY MARIO RODRIGUEZ

ONLINE ► **A Quick Spin**

In this free video, watch the author put this jig through its paces – seeing is believing.

popularwoodworking.com/aug13

40 **William & Mary Spice Chest**

Work with the tools used by an 18th-century craftsman to build a miniature high chest inspired by a costly Philadelphia antique.

BY ZACHARY DILLINGER

ONLINE ► **Cut Mouldings by Hand in Minutes**

Watch – in real time – the making of an ovolo moulding using handplanes.

popularwoodworking.com/aug13

47 **Double-bevel Artistry**

Stunning inlay, even a fleur-de-lis, is a “piece of cake” when you follow these simple steps.

BY JAMEEL ABRAHAM

ONLINE ► **Shop-sawn Veneer**

Learn the tips, tricks and techniques needed to cut veneer in your shop.

popularwoodworking.com/aug13

51 **Southern Gent's Mirror Stand**

Reflect on Southern sensibilities as you build this piece from the North Carolina Piedmont.

BY GLEN D. HUEY

ONLINE ► **Bump-cut Tenons**

Watch the author demonstrate a simple technique for cutting tenons at the table saw.

popularwoodworking.com/aug13

30



CONTENTS

AUGUST 2013



14

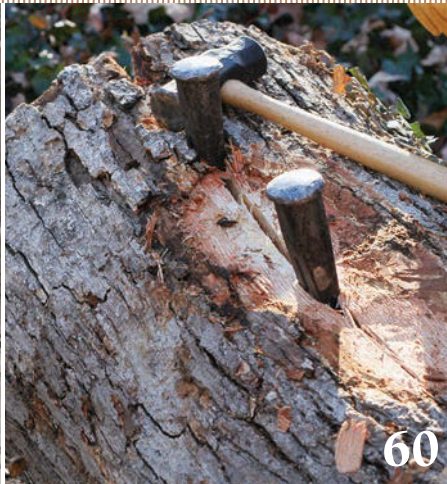

60



62

REGULARS

6 A Million Laughs & Lots of Woodworking

OUT ON A LIMB

BY MEGAN FITZPATRICK

8 Two Methods For Square Ends

LETTERS

FROM OUR READERS

12 Recycled Creamer Bottles Store Finish

TRICKS OF THE TRADE

FROM OUR READERS

VIDEO ▶ More Tricks

Read and watch some of our favorite tricks.

popularwoodworking.com/tricks

14 Infinity Shrinks The Dado Stack

TOOL TEST

BY THE EDITORS

ONLINE ▶ Tool Test Archives

We have many tool reviews available for free on our web site.

popularwoodworking.com/tools

18 Train Your Eye

DESIGN MATTERS

BY GEORGE R. WALKER

58 The Hole Story

WOODWORKING ESSENTIALS

BY MEGAN FITZPATRICK

60 Logs to Lumber

ARTS & MYSTERIES

BY ADAM CHERUBINI

62 Revive or Restore?

FLEXNER ON FINISHING

BY BOB FLEXNER

64 Conquer Finish Fears

END GRAIN

BY DAVID MATHIAS



58

POPULAR
Woodworking
MAGAZINE

Number 205, August 2013. *Popular Woodworking Magazine* (ISSN 0884-8823, USPS 752-250) is published 7 times a year, February, April, June, August, October, November and December, which may include an occasional special, combined or expanded issue that may count as two issues, by F+W Media, Inc. Editorial and advertising offices are located at 8469 Blue Ash Road, Suite #100, Cincinnati, OH 45236. Unsolicited manuscripts, photographs and artwork should include ample postage on a self-addressed, stamped envelope (SASE); otherwise they will not be returned. Subscription rates: A year's subscription (7 issues) is \$24.95; outside of the U.S. add \$7/year • Canada Publications Mail Agreement No. 40025316. Canadian return address: 2835 Kew Drive, Windsor, ON N8T 3B7 • Copyright 2013 by *Popular Woodworking Magazine*. Periodicals postage paid at Cincinnati, Ohio, and additional mailing offices. Postmaster: Send all address changes to *Popular Woodworking Magazine*, P.O. Box 420235, Palm Coast, FL 32142-0235 Canada GST Reg. #R132594716 • Produced and printed in the U.S.A.



SEASONED PROFESSIONAL OR AMATEUR?

Shopsmith Premium Abrasives ARE SURE TO IMPRESS!

What Makes Our Abrasives So Impressive?

We only use the *BEST* of the *BEST*!
Our Discs are made with Film (*not paper*)
creating a stronger, flatter surface,
producing unsurpassed scratch patterns.

Equally impressive, are our premium Ceramic Belts!
Made with Polyester Cotton cloth backing and
razor sharp ceramic grain, these belts are
guaranteed to outperform all others.



www.shopsmithabrasives.com



CARD #55 or go to PWFREINFO.COM

AUGUST 2013, VOL. 33, NO. 4

popularwoodworking.com

EDITORIAL OFFICES 513-531-2690

GROUP PUBLISHER ■ Jamie Markle
jamie.markle@fwmedia.com, x11452

PUBLISHER & GROUP EDITORIAL
DIRECTOR ■ Kevin Ireland
kevin.ireland@fwmedia.com, x11407

EDITOR ■ Megan Fitzpatrick
megan.fitzpatrick@fwmedia.com, x11348

SENIOR ART DIRECTOR ■ Daniel T. Pessell
daniel.pessell@fwmedia.com, x11396

EXECUTIVE EDITOR ■ Robert W. Lang
robert.lang@fwmedia.com, x11327

SENIOR EDITOR ■ Steve Shanesy
steve.shanesy@fwmedia.com, x11238

MANAGING EDITOR ■ Glen D. Huey
glen.huey@fwmedia.com, x11005

ONLINE COMMUNITY MANAGER ■ Tom Nunlist
tom.nunlist@fwmedia.com, x11008

CONTRIBUTING EDITORS ■ Adam Cherubini,
Bob Flexner, Christopher Schwarz

PHOTOGRAPHER ■ Al Parrish

F+W MEDIA, INC.

CHAIRMAN & CEO ■ David Nussbaum

COO & CFO ■ James Ogle

PRESIDENT ■ Sara Domville

CHIEF DIGITAL OFFICER ■ Chad Phelps

VICE PRESIDENT, E-COMMERCE ■ Lucas Hilbert

SENIOR VICE PRESIDENT,
OPERATIONS ■ Phil Graham

VICE PRESIDENT, COMMUNICATIONS ■ Stacie Berger

ADVERTISING

VICE PRESIDENT, SALES ■ Dave Davel

ADVERTISING DIRECTOR ■ Don Schroder

331 N. Arch St., Allentown, PA 18104

TEL. 610-821-4425; FAX. 610-821-7884

d.schroder@verizon.net

ADVERTISING SALES

COORDINATOR ■ Connie Kostrzewa

TEL. 715-445-4612 x13883

connie.kostrzewa@fwmedia.com

NEWSSTAND

For newsstand sales, contact Scott T. Hill:
scott.hill@procirc.com

SUBSCRIPTION SERVICES:

Subscription inquiries, orders and address changes can be made at popularwoodworking.com (click on "Customer Service"). Or by mail: *Popular Woodworking Magazine*, P.O. Box 420235, Palm Coast, FL 32142-0235. Or call 386-246-3369. Include your address with all inquiries. Allow 6 to 8 weeks for delivery.

NEWSSTAND DISTRIBUTION:

Curtis Circulation Co., 730 River Road, New Milford, NJ 07646. PHONE: 201-634-7400. FAX: 201-634-7499.

BACK ISSUES are available. Call 800-258-0929 for pricing or visit popularwoodworking.com. Send check or money order to: *Popular Woodworking Magazine* Back Issues, F+W Media Products, 700 E. State St., Iola, WI 54990. Please specify publication, month and year.

Copyright ©2013 by F+W Media Inc. All rights reserved. *Popular Woodworking Magazine* is a registered trademark of F+W Media.



A Million Laughs & Lots of Woodworking

When Christopher Schwarz first told us in 2008 about his crazy idea for a woodworking conference, it felt a bit like the film "Babes in Arms." "We've gotta have a great show, with a million laughs... and lots of lights to make it sparkle... And after we get the people in that hall, we've gotta start 'em laughing right away. Oh, can't you just see it?"

But with just a few months of frantic planning, I think we pulled it off. For the first Woodworking in America (WIA) conference, more than 300 woodworkers descended on the tiny town of Berea, Ky., and the college there for three days of woodworking fun, education and camaraderie.

Six years later, the conference has expanded from its initial pure hand-tool focus to also include furniture design, power-tool techniques, marquetry, turning, woodworking, tool history and more (though hand-tool education remains at the core of the annual event). And, we've since expanded the venue to allow room for more folks to enjoy and learn from the experience.

In the Marketplace, we gather everyone from large companies that make high-quality machines and tools to small companies with a limited line of excellent offerings to individual makers who build high-end, bespoke hand tools of all sorts. As a result, you get to try out a huge array of tools – and in some cases even get to know the maker – before you make that special, perhaps once-in-a-lifetime purchase.

But trying – and buying – tools is only a part of the conference. The core purpose of WIA is to expose you to a rich and wide variety of expert crafts-

people, tools and woodworking skills, and provide face-to-face instruction from some of the best woodworkers alive today.

This year, we're bringing back many of your favorite speakers from conferences past (Roy Underhill, Christopher Schwarz, Mary May, Don Williams and Ron Hock to name just a few), and we've invited some new experts, including Silas Kopf, Peter Ross and Ejler Horsth-Westh.

All told, there will be presentations on more than 35 topics (in 55+ sessions) over the weekend – from chairmaking to marquetry, handplanes to router joinery, dovetails to period finishing, timber work to working with curves, carving to tool chests. Plus,

based on your suggestions, we've expanded some of the session lengths to allow for more in-depth education and discussion.

We're also bringing back the WIA Banquet, so we can gather together in one room to share a meal with 450 of our closest woodworking friends (old and new) and enjoy a special presentation.

For a complete list of speakers, session descriptions, the schedule, special events, Marketplace vendors and registration, visit the conference web site at WoodworkingInAmerica.com.

I hope you'll mark your calendar for Oct. 18-20 and join us in Northern Kentucky.

Together, we'll have a great show, learn a lot and have a million laughs.

PWM



free WEB TV
for woodworkers.
September 2013

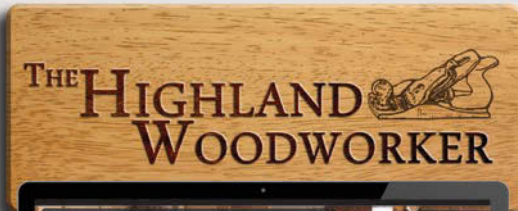

Hosted by Charles Brock

www.thehighlandwoodworker.com

CARD #91 or go to PWFREEINFO.COM

New product



EASY CHUCK™

4" Woodturning Chuck

Thread Sizes: 1" - 8, 1 1/4" - 8, and M33 - 3.5



With these exclusive features:

Easy Jaws

Change out jaw sets in under 30 seconds and get right to your next project

Zoom Ring

Quickly adjust the gripping diameter with just your fingertips! Then final tighten with included chuck key

Other Easy Chuck exclusives:

Hardened jaws and jaw slides will last for generations

Rounded jaw corners for safety that will not cut your knuckles

Jaws are not numbered because they can go in any slot

Strong jaw design uses no screws for mounting

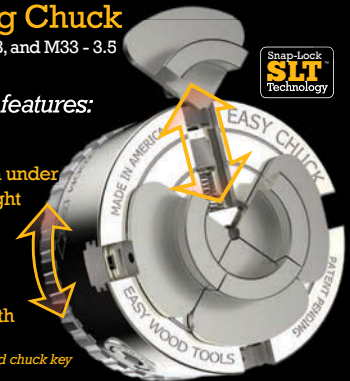

www.woodturning.com | 1-866-963-0294

CARD #39 or go to PWFREEINFO.COM

Clamping Technology | Cutting Technology | Precision Steel



BESSEY® – 120 years of superior innovation, customer service and product quality in clamping, cutting and steel technology.

Make the most of our innovative edge – experience and see for yourself why BESSEY® is **Simply Better.**

**See us at AWFS,
Booth 9215**



www.besseytools.com

E-Newsletter: info@besseytools.com

AUTO-ADJUST TOGGLE CLAMP

Auto-adjusts to variations in work piece dimensions while maintaining constant clamping force from 25-550 lbs.



See the NEWEST BESSEY PRODUCTS

- 5 new toggle clamps
- Rapid Action PZ clamps
- Flooring tools

CARD #46 or go to PWFREEINFO.COM

Two Methods for Square Ends

I'm building a cherry plywood cabinet to house my electronic equipment. The top and bottom pieces are 70" long, so I don't feel comfortable using my table saw to make the crosscuts. But I did use it to rip both pieces to width.

I bought a clamp guide to guide my router so I could trim one end square. Unfortunately, I cannot get both corners square after I make my cut. The more I take off, the worse it gets. I know both long edges are parallel because I've measured the width at the ends and my measurements are equal. If the edges are parallel and I'm using a clamping guide, shouldn't the ends be square?

Joe Scanlon
Cincinnati, Ohio

Joe,
If the sides are parallel and your cut is still off, then your clamp guide is not set square—it's an easy error to make. Here's what I suggest: Use a square to draw a line across your workpiece, but make sure that your tool is indeed square before you

begin. Clamp your guide, aligned to that layout line or to your square itself, then make your cut.

A second option is to use a shop-made jig to guide your router with a top-mounted router bit installed. I use a piece of plywood about 8" wide with a 4"-wide piece of plywood glued and screwed on top—run the double-thick edge over a jointer to ensure that it is straight.

Clamp the jig square to your workpiece, set your router on top of the jig, then adjust the depth of cut so the bit's bearing rides along the jig's jointed edge. To make a cut, run the bit tight to your jig as you trim to your layout line. Because the jig is positioned at your layout line, the resulting cut has to be as square as your line. I guarantee this procedure works; I've been using it for years.

Glen D. Huey, managing editor

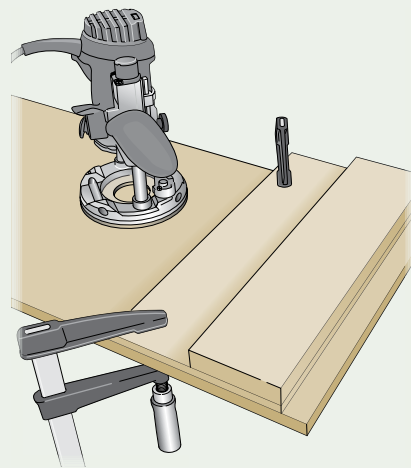
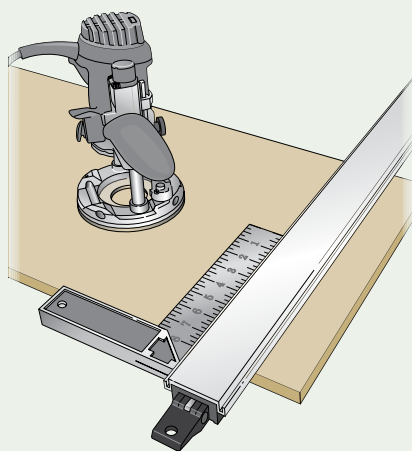

A 'Must-have' Rule

While I find myself in agreement with almost every point made by Robert W. Lang in "Mark, Measure & Layout" (April 2013, issue #203), he did fail to mention one "must-have" measuring device—a hook rule. One of my 6" hook rules is always close at hand, and it enables me to measure and mark without worrying about whether I'm exactly lined up with the edge of my wood. These rules are relatively inexpensive and available from numerous sources.

Ron Kellison
Ottawa, Ontario

Roorkee Chair Supplies

I have read the article on the Roorkee chair from October 2012 (issue #199), and have reviewed the many blog posts

about the chair. Christopher Schwarz's design seems to change a little with every post.

I have started making my own chair, and I am to the point where I need to buy the leather, buckles and so on. I'm on a budget and don't want to buy the wrong leather and hardware.

Please offer some quick advice.

Lawrence Wroten
via e-mail

Lawrence,
I'm not changing the construction process to improve it, necessarily. I'm mostly altering it for volume production or to satisfy my customers.

A medium-weight leather (5 ounce) is a good weight, and vegetable-tanned leather is tough stuff—certainly tough enough to use on a chair.

If I were making one chair for myself, I'd use copper rivets to make the back, and buckles to make the seat strap and the seat. That way there is no stitching. You can hand stitch this if you like. It's not hard, but you will have to buy more tools, so that's why I'd go for rivets. Cheap. Low skill. Fast.

Christopher Schwarz,
contributing editor

Table Saw Coves are Safe

By odd coincidence, yesterday I made my first cove cut much as described in Gary Rogowski's article, "Cove Cuts on the Table Saw" (April 2013, issue #203). I am fascinated by the subject; however, I see one serious danger in the method described. The way Gary has set up his jig, the saw blade is pushing the workpiece away from the jig and

CONTINUED ON PAGE 10

OSBORNE
Wood Products, Inc.

Fables

Come Visit us at AWFS
Booth 4809
July 24-27, 2013

Scan code to visit
our table kits

866.963.5576
www.woodenlegs.com

CARD #36 or go to PWFREEINFO.COM

Custom Branding Irons
Distinctive marking for your craft

P: 586.484.7713 • www.branding-irons.biz

CARD #93 or go to PWFREEINFO.COM

Woodworker's Supply, Inc.
Since 1972
"Where the experts buy their tools"

If you are in a woodworking business... this could be the most valuable tool in your office.sm

Please call
1-800-321-9841
for your 750 page catalog AND
mention code pw0113

FREE
to woodworking
businesses.

Visit us at
pro.woodworker.com/pw0113

CARD #54 or go to PWFREEINFO.COM

Oneida Air Systems is #1 at Collecting Dust!

In WOOD® Magazine's (May 2013) Air Quality Test the Oneida V-System dust collector was the best at keeping airborne dust levels lowest in the wood shop.

See the complete test results on our website at www.oneida-air.com.

**WOOD MAGAZINE
TOP
TOOL
APPROVED
2013**

V - Systems 3000

"With the smoothest-running impeller, heaviest-gauge steel, best overall fit and finish, and superior dust filtration, this 3-hp cyclone was the cream of the crop. Another plus: it's second quietest, below the threshold of potential hearing loss (85 dB)."

WOOD® Magazine - May 2013

Pat. Pend.

"Oneida is committed to building the best possible dust collection systems while keeping jobs here in America."

Robert Witter - President, Oneida Air Systems, Inc.

Proudly Made in the USA.

Like Dust Collection Systems and Components Since 1993.

Call Today for **FREE** Catalog!
1.800.732.4065
www.oneida-air.com

CARD #35 or go to PWFREEINFO.COM

toward the operator. If the fence and jig were on the infeed side of the saw blade, the workpiece could still move right to left over the blade, but the force of the blade would be going toward the jig and not into thin air – and potentially the operator.

Jonathan Leavy
Newton, Massachusetts

Jonathan,
Thank you for your letter and concerns about my method for cove cutting. As I tell my students, when you walk through the door of a woodshop you are at risk. It's a dangerous place. There is no point in making things worse. But I am confident that my method does not pose a threat to any woodworker if approached as I wrote.

Small depths of cut with each pass means that the saw blade is cutting at the top of its rotation then mostly down and into the table. This pushes the work into the table, not away from the fence. It is quite simple to then hold the piece against the fence and so much easier to feed in this fashion—at least for a right-hander such as myself.

The key, of course, is taking a light pass. A heavy pass is harmful to the blade and perhaps to the woodworker. My experience at the table saw tells me that when I can see the fence I also know how the workpiece will contact the blade; whatever happens at the fence happens at the blade next.

So with the fence set as I suggest, I have good sight lines on the piece and fence, and good pressure against the fence. With the fence set as you suggest, I find myself pulling the piece back into the fence as I'm trying to move it along. This awkwardness makes me feel at risk.

The geometry of the cut does not move the wood away from the fence at shallow passes. Raise the blade to dangerous heights, and I agree that you'll have problems because the back part of the blade is cutting. But cut as I suggest and there won't be an issue.

Gary Rogowski, contributor

What's in a Name?

I am a long-time reader of *Popular Woodworking Magazine*, and a reader of the blog. A while back, I saw an ar-

ticle by Christopher Schwarz regarding a name stamp. I suggested to my wife that a name stamp would make a good Christmas present because she is forever after me to sign my work. (Instead, I unwrapped a set of drawbore pins; yep, she's a keeper.) However, I have searched the blog archive high and low and cannot find the article in question, nor do I remember the supplier from which Christopher purchased his stamp. Can you help me out and point me in the right direction?

Jeff Kellen
via e-mail

Jeff,
Christopher has written about several stamps. His first, the C SCHWARZ stamp, was made by Mazzaglia Tools in Salem, N.H. (mazzagliatools.com). That stamp was shown in the End Grain column of *Woodworking Magazine* (Summer 2008, issue #10); like your drawbore pins, it was a gift from his wife, as he writes in the article.

More recently, Christopher blogged about purchasing his Lost Art Press logo stamp from Infinity Stamps. (For additional information, visit his blog at lostartpress.com and search for "Infinity.")

But if you want a really special name stamp, consider taking a class with Peter Ross at Roy Underhill's school and make your own (visit woodwrightschool.com for upcoming classes). P.W.M.

Megan Fitzpatrick, editor

ONLINE EXTRAS

Letters & Comments

At popularwoodworking.com/letters you'll find reader questions and comments, as well as our editors' responses.

We want to hear from you.

Popular Woodworking Magazine welcomes comments from readers. Published correspondence may be edited for length or style. All published letters become the property of *Popular Woodworking Magazine*.

Send your questions and comments via e-mail to popwood@fwmedia.com, or by mail to 8469 Blue Ash Road, Suite 100, Cincinnati, OH 45236.

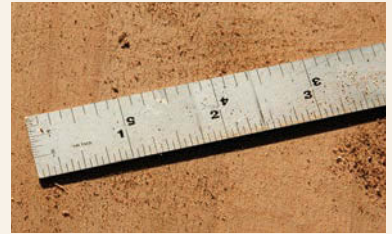

Highly Recommended

For accuracy in woodworking, a 6" steel rule is a must. I'll take my Shinwa rule over other comparable tools. Its 3/4" width makes it easy to handle, it's rigid enough for heavy use, and the satin finish cuts glare to make it easy to read the measurements (which extend completely to the end of the rule).

Shinwa rules are marked in increments of 1/8", 1/16", 1/32" and 1/64", which cover most necessary woodworking needs, and the ends are marked in increments of 1/32" – perfect for router setups (\$11.50 at leevalley.com #60N47.01).

— Glen D. Huey

POPULAR Woodworking MAGAZINE

Customer Service

How can I contact customer service with questions regarding my subscription, including a lost or damaged issue?

Visit popularwoodworking.com/customerservice. Or write to *Popular Woodworking Magazine*, P.O. Box 421751, Palm Coast, FL 32142-1751. Or, if you prefer the telephone, call 1-877-860-9140 (U.S. & Canada), 386-246-3369 (International) and a customer service representative will be happy to help you.

When does my subscription expire?

The date of your subscription expiration appears on your magazine mailing label, above your name. The date indicates the last issue in your subscription.

Can I get back issues of *Popular Woodworking and Woodworking Magazine*?

Back issues are available while supplies last. Visit popularwoodworking.com/backissues. Or if you know the exact month and year of the issue you want, call our customer service department toll-free at 855-840-5118 to order.

What if I want more information about the projects and tools I read about in *Popular Woodworking Magazine*?

For all editorial questions, please write to *Popular Woodworking Magazine*, 8469 Blue Ash Road, Suite 100, Cincinnati, OH 45236. Or e-mail popwood@fwmedia.com.

Does *Popular Woodworking Magazine* offer group discounts?

Group discounts are available by special arrangement with the publisher. For more details, send an e-mail to Debbie.Paolello@debbe.paolello@fwmedia.com or call 513-531-2690 x11296.

Our Privacy Promise to You

We make portions of our customer list available to carefully screened companies that offer products and services we believe you may enjoy. If you do not want to receive offers and/or information, please let us know by contacting us at:

List Manager, F+W Media, Inc.
10151 Carver Road, Suite 200
Blue Ash, OH 45242

Safety Note

Safety is your responsibility. Manufacturers place safety devices on their equipment for a reason. In many photos you see in *Popular Woodworking Magazine*, these have been removed to provide clarity. In some cases we'll use an awkward body position so you can better see what's being demonstrated. Don't copy us. Think about each procedure you're going to perform beforehand.

WOOD SLICER

Legendary Resaw Blade

- Cuts smoother
- Works faster
- Sounds quieter
- Stays sharp longer
- Makes veneers

Only at
HIGHLAND
Woodworking

FWW
rated best

800-241-6748

highlandwoodworking.com

CARD #22 or go to PWFREEINFO.COM



**Lie-Nielsen
TOOLWORKS[®]**
INC.

NEW!
TAPERED CARCASS SAW

I-800-327-2520
www.lie-nielsen.com
Made in Warren, Maine

CARD #29 or go to PWFREEINFO.COM

WWW.RADARCARVE.NET

Wood Carving Duplicators

- Furniture
- Gunstocks
- Millwork
- Decoys
- Musical Instruments

Incredibly accurate



Thousands of Uses 505-948-0571

CARD #38 or go to PWFREEINFO.COM

STEVE WALL LUMBER CO.

Quality Hardwoods and Woodworking machinery For The Craftsman
and Educational Institutions

Ash	4/4	Select	\$ 2.60	\$ 94.00
Basswood	4/4	Select	\$ 1.95	\$ 80.00
Birch	4/4	Select	\$ 3.55	\$ 108.00
Butternut	4/4	1C	\$ 2.95	\$ 88.00
Cherry	4/4	Select	\$ 4.90	\$ 117.00
Hickory - Pecan	4/4	Select	\$ 3.00	\$ 100.00
Mahogany (Genuine)	4/4	Select	\$ 4.70	\$ 112.00
Maple (Hard)	4/4	Select	\$ 3.45	\$ 108.00
Maple (Soft)	4/4	Select	\$ 2.50	\$ 88.00
Poplar	4/4	Select	\$ 1.80	\$ 78.00
Red Oak	4/4	Select	\$ 2.70	\$ 96.00
Walnut	4/4	Select	\$ 4.90	\$ 115.00
White Oak	4/4	Select	\$ 2.70	\$ 96.00
Cedar (Aromatic Red)	4/4	1C+Btr.	\$ 1.80	\$ 75.00
Cypress	4/4	Select	\$ 2.60	\$ 90.00
White Pine	4/4	F.G.	\$ 1.25	\$ 70.00
Yellow Pine	4/4	Clear	\$ 2.30	\$ 82.00

**UPS
Specials**

**SEE OUR
CATALOG ON
THE WEB!**

Above prices are for 100' quantities of kilndried rough lumber sold by the Bd. Ft. FOB Mayodan, NC. Call for quantity discounts. Other sizes and grades available. Above prices are 20 bd. ft. bundles of clear kilndried lumber 3"-10" wide x 3'-5' long (Random widths & lengths) Surfaced 2 sides or rough. Delivered UPS prepaid in the Continental U.S.

OLIVER MACHINERY DEALER

HARDWOOD PLYWOOD

CUSTOM RAISED PANEL DOORS

CUSTOM PLANK HRDWD FLOORING

THIN CRAFTWOOD

EXOTIC LUMBER

**STEVE H. WALL
LUMBER CO.**

BOX 287

MAYODAN, N.C. 27027

336-427-0637

1-800-633-4062

FAX 336-427-7588

Email: wood@walllumber.com

Website: www.walllumber.com

Send \$1.00 For Lumber Catalog

Prices Subject to Change Without Notice

CARD #47 or go to PWFREEINFO.COM



**POPULAR
Woodworking
MAGAZINE**

SEARCHABLE □ PRINTABLE □ PORTABLE

**ALL 1995 through 2012
Issues On One DVD**

BONUS:
"Spons on Carpentry & Joinery" - a 276-page reprint (in PDF format) from a 1910 book on hand and machine woodworking. Edge, including design, planing, joinery and more.

BONUS:
Get the "Spons on Carpentry & Joinery" 276 page PDF included on the DVD!

Discover 18 Years of Pure Woodworking INFORMATION!

With more than 8,500 pages, this DVD includes a huge range of project plans in a variety of styles, tool reviews, essential technique instruction, and so much more.

Order your copy today to explore:

- Hundreds of plans for furniture, jigs, toys, and more, including step-by-step instruction and drawings for good-looking beginner builds to masterpiece projects.
- Tons of shop projects including workbenches, router tables, sawhorses, and more.
- Essential technique instruction in power- and hand-tool approaches for common operations, plus finishing advice, design instruction, and more.
- And so much more!

This and many more *Popular Woodworking* DVDs are available at ShopWoodworking.com or call (855) 840-5118 to order

THE WINNER:

Recycled Creamer Bottles Store Finish

Most of us have leftover paint, wiping stain and finish from our projects. I try my best to seal any product in its original container, but even then, time has a way of congealing my leftovers.

One day I reached for my “Coffee-mate” non-dairy, liquid creamer for my coffee – the one that has a red flip-up cap that screws onto a white collar set atop a clear bottle – and saw that the bottle had been knocked over. Thinking the worst, I looked to see what needed to be cleaned up, but found nothing. The container has a tight, durable pouring lid with an ingenious seal.

I snagged an empty bottle from the trash, cleaned it, peeled off the shrink-wrap label and conducted a few experiments in the shop. I was

very impressed. Even when full and turned upside down, the bottle doesn’t leak. And it withstands a moderate drop before the top pops open. (Grandchild tested.)

After two years, several of my bottles have stored paint with none of it skimmed over. My wipe-on polyurethane has been in the same bottle for more than a year and shows no sign of degradation. I can mix stain in the bottle, shake it and see the results through the clear plastic shell. It also makes identification on the shelf easier.

This bottle isn’t limited to shop use. I also use it to store dry goods in the pantry, and it makes great drink-storage bottles for the little ones.

Philip Hyde Jr.
Melbourne, Florida

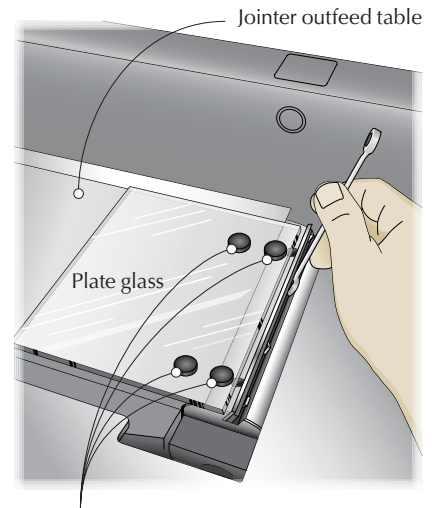

Rare-earth magnets on top of glass

Use Glass to Set Jointer Knives

A piece of thick plate glass is dead flat and it’s easy to use to align standard jointer knives that have gib screws. A couple of rare-earth magnets secured to the glass with double-sided tape keep it flat on the jointer’s outfeed table. Two more magnets on the glass over the cutterhead serve as an alignment tool for setting the blade height.

To use the jig, slightly lower the jointer infeed table to make it easier to access the cutterhead, then remove the first dull knife. Set your replacement blade loosely in its cutterhead slot, then slowly rotate the cutterhead until the sharp edge of the new knife reaches the apex of travel. The glass plate, positioned on the outfeed side of the jointer, is then pressed onto the top edge of the blade where the magnets grab and hold the knife edge against the bottom of the glass. To complete the installation, tighten the gib screws. The process is repeated for the remaining blades.

The glass and magnets not only establish the blade height flush to the outfeed table but also keep the knife flat and true across the width of the jointer’s outfeed table. With all the knives changed, raise the infeed table to the desired height for a test cut.

Brian Mayeaux
Houston, Texas

Vacuum-hose Support

I provide support for my vacuum hose and hold its business end exactly where I want it, as shown in the illustration at right. This setup makes arranging dust collection at challenging locations quick and easy. To secure the hose, I cut out a segment of a 1½"-diameter PVC pipe coupling at a little more than 90°. A piece of that size easily snaps over the 2"-diameter roller on my material-support stand.

I use a hose clamp around the hose and the pipe coupling to hold the vacuum hose on the roller. I also use epoxy to secure two rare-earth magnets to the vacuum attachment;

the magnets secure the setup to the table saw top or on any other tool that has a cast iron top.

Mike Gunderson
Yakima, Washington

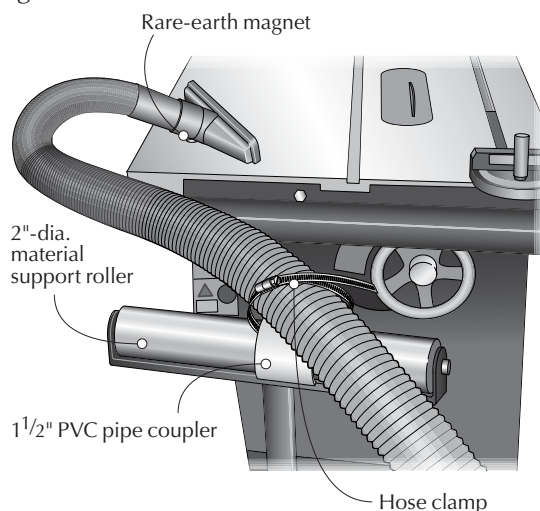

Perfectly Cambered Clamping Cauls

I was recently faced with a glue-up that required several pairs of cambered clamping cauls. I needed a way to create perfectly smooth, square-edged cauls with an even, gradual curve from end to end – without spending hours to make them. I came up with this idea and it worked like a charm.

I chose common 2x6 lumber for my caul material, and selected boards that were flat-sawn and dry. I planed and jointed the faces to get them nice and flat, then cut them to length and marked the centers. I made a pencil line set 5" to each side of the center mark to define a 10"-long section at the middle of the boards. At the table saw, cutting from each end, I made a rip cut to the 5" mark closest to that end, then stopped the cut. I did the same on the opposite end to leave me with a 2x6 that was ripped almost in two, with the two halves still connected by a 10" center section.

I next cut wedges from scrap $\frac{3}{4}$ "-thick hardwood that were about 6" long and $\frac{3}{8}$ " at the wide end of the wedge. I drove these wedges lengthwise into the saw kerfs at the ends of the caul material. (This is one reason for choosing flat-sawn material. If the

boards were quartersawn, they might split apart when wedged.) With the wedges in place, I ran both edges over the jointer to straighten them. I then removed the wedges and sawed the remaining 10" section using my rip saw. (There is no longer a straight edge to guide the cut using a table saw.)

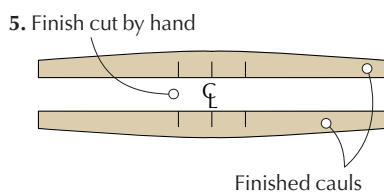
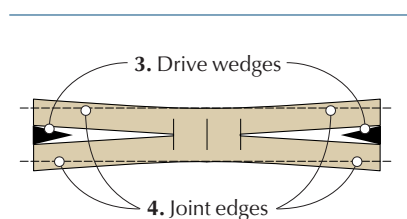
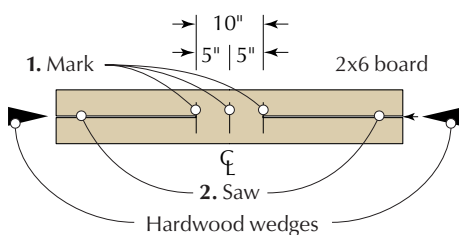

Veritas Hold-Down Support Blocks

I like to use my Veritas Hold-Down to clamp boards to my benchtop while chopping dovetails. The problem with the hold-down (especially when doing

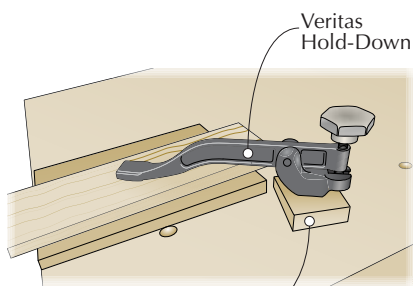

Support block

repetitive tasks) is that it drops into the bench-dog hole every time I remove the board it was holding.

My fix is a simple one that makes the tool a delight to use. Cut a piece of scrap about the same thickness as the wood you're holding. Drill a $\frac{3}{4}$ "-diameter hole through the scrap then slip the hold-down shaft through the hole to support the clamping arm when placed in the dog hole.

Make the support blocks in several thicknesses and keep them handy. You can also stack the blocks under the hold-down to provide whatever height you need for the work you are clamping.

Ed Grant

Ulster, Pennsylvania

The cauls came out smooth and perfect with just the right amount of curve. Each pair took less than 10 minutes to make and cost only a couple of dollars.

My cauls are 5' long, and the pressure they bear on the work is perfect. Longer or shorter cauls can be made from wider or narrower material and a different wedge size will yield more or less curvature.

This process worked so well that I have since made several other pairs just to have them on hand for future glue-ups. **PWM**

John VanDeMar
Rochester, New York

ONLINE EXTRAS

For links to all online extras, go to:

■ popularwoodworking.com/aug13

TRICKS ONLINE: We post tricks from the past and film videos of some *Tricks of the Trade* in use in our shop. They're available online, free. Visit popularwoodworking.com/tricks to read and watch.

Our products are available online at:

■ ShopWoodworking.com

Cash and prizes for your tricks and tips!

Each issue we publish woodworking tips from our readers. Next issue's winner receives a \$250 gift certificate from Lee Valley Tools, good for any item in the catalog or on the web site (leevalley.com). (The tools pictured below are for illustration only, and are not part of the prize.)

Runners-up each receive a check for \$50 to \$100. When submitting a trick, include your mailing address and phone number. All accepted entries become the property of *Popular Woodworking Magazine*. Send your trick by e-mail to popwoodtricks@fwmedia.com, or mail it to *Tricks of the Trade*, *Popular Woodworking Magazine*, 8469 Blue Ash Road, Suite 100, Cincinnati, OH 45236.



Infinity Shrinks the Dado Stack

‘Dadonator Jr.’ is small in size but big on performance.

Regardless of what you may think, size doesn't matter—at least not when you're talking dado stacks. Infinity Cutting Tools' 8" "Dadonator" was highly touted when it was released in 2008. Today, Infinity offers the "Dadonator Jr." It's the same tool only smaller in diameter (6") and price.

Does a 2" reduction in diameter affect work in the shop? No. You seldom use the maximum depth-cutting capacity that's possible with an 8" dado

stack; the 1¼" capacity of the Dadonator Jr. will satisfy most of what you ask of this table saw accessory.

The 6" stack has 24 carbide teeth on the outside cutters, and each chipper has six carbide teeth (two more teeth than what's found on the chippers of competing stacks).

After putting Infinity's new stack to work, I found it performs as well as its big brother. Junior's cuts are flat-bottomed and smooth, and there's no tear-out or splintering of surface wood when cutting with or across the grain.

The Dadonator Jr. set includes four ⅛" chippers, one ⅓" chipper and one



⅜" chipper, which is handy for cutting dados in plywood. With Junior, you can cut dados in widths from ¼" to 29/32". Also included in the set are shims that allow you to fine-tune any setup.

— Steve Shanesy

Dadonator, Jr.

Infinity Cutting Tools ■ infinitytools.com
or 877-872-2487

Street price ■ from \$190

■ ARTICLE Read the full review of the 8" Dadonator from our October 2004 issue.

Prices correct at time of publication.

Amana Countersinks Conquer Burning & Marring

Amana Tool has four new countersinks with various-sized drill bits and non-marring depth stops.

Each countersink has twin carbide-tipped flutes, and these are the only countersinks in the industry with this feature. Carbide-tipped flutes allow the bit to cut cleanly and last longer when working with hardwoods, plywoods and other engineered wood products.

Two set screws allow for quick adjustment of the drill-bit length and of

the ⅜"-diameter countersink. (A hex key is included with each countersink.) You can dial in the exact setting for perfect plug holes at ⅜". Or if you need a bit more depth, simply remove the stop and the countersink drills to ½".

To eliminate marring, the tool's adjustable depth stop features a pressed-in roller bearing that quickly stalls the spin as soon as the stop makes contact with the surface of the work. Also, there are two side openings in the depth stop that allow chips to escape from below the tool.

The drill bits are the standard straight twist design and are available in four different sizes, the smallest of which is 3/32". Other diameters include ⅛", 9/64" and 9/64". Those sizes should take care of your pilot hole needs for the most-often used screws.

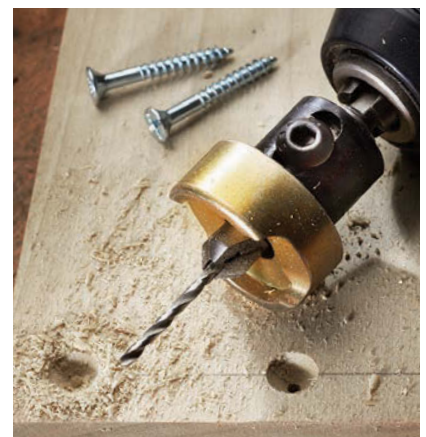

Carbide-tipped countersinks are better because they remain sharp longer than high-speed steel countersinks. They also cut smooth, clean holes with less tear-out around the perimeter.

— SS

Carbide Countersinks

Amana Tool ■ amanatool.com or
800-445-0077

Street price ■ from \$37 to \$38

■ ARTICLE Learn more about countersinks and countersink bit designs.

Prices correct at time of publication.

CONTINUED ON PAGE 16

THE ULTIMATE WOODWORKING WEEKEND

WOODWORKING
In America



OCTOBER
18 - 20, 2013

JOIN THE WORLD'S BEST WOODWORKERS for a weekend packed with skill-building sessions, aisles of top toolmakers, and social events where you can talk shop with legendary craftspeople.

- **SHARPEN YOUR HAND- AND POWER-TOOL SKILLS** in more than 35 sessions on inlay, joinery, dovetails, carving, turning, marquetry and more.
- **GET INSPIRED BY NEARLY TWO DOZEN MASTER WOODWORKERS** including Peter Galbert, Roy Underhill, Silas Kopf, Mary May and Christopher Schwarz.
- **STOCK UP ON TOOLS AND SUPPLIES WHEN YOU SHOP** the WIA Marketplace, where you'll find more than 50 top hand tool and power tool makers.



LEARN MORE AND REGISTER NOW

WWW.WOODWORKINGINAMERICA.COM

SPONSORED BY

SHOP
Woodworking



BOSCH
Invented for life



Clever Spyder Jigsaw Blades Make Super-tight Turns

Spyder, a Kansas City, Mo.-based company, has introduced a jigsaw blade with teeth on the front and back edges. At first glance, these blades look odd at best and gimmicky at worst. But after taking these blades for a test-drive, I began to understand the versatility offered by this innovation. Of course it's possible to cut moving backward, but the bigger surprise is how tight of a radius cut you can make – less than $\frac{3}{4}$ " in diameter.

The back teeth, as well as the narrow $\frac{3}{16}$ " blade width, make those tight

cuts possible by slightly opening the kerf without chewing up the surface.

If you're wondering if the teeth positioned on the back edge of the blade gnaw on the jigsaw's blade guide, they don't – the teeth don't reach the guide even with the blade fully retracted.

Cutting in reverse is a handy feature when you want to saw normally then change direction at an acute angle; obvious applications are operations you would otherwise do using a scroll-saw. But simple direction changes also make sawing away most of the waste in a dovetail much easier than when using typical jigsaw blades.

These durable, hardened steel blades are made in Germany specifically for Spyder. Two tooth designs are available: the 4½"-long blades are designed for hardwoods, softwoods and other wood-based products such as plywood. The 4"-long blades are best for fiberboard and plastics (but also work in

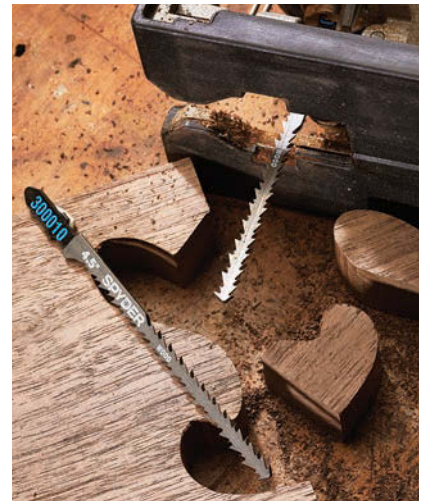

softwood). Both have T-shanks, and are sold in packages of two.

Spyder double-sided jigsaw blades may not replace your everyday jigsaw blades, but they are worth keeping on hand for many special applications.

—SS

Double-sided Jigsaw Blades

Spyder Products ■ spyderproducts.com
or 888-471-2239

Street price ■ \$7 for two

■ VIDEO See the Spyder double-sided jigsaw blade in action.

Prices correct at time of publication.

Vesper Tools Try Square: Perfect & Functional

Every shop needs a square that is the ultimate arbiter of squareness. It is the tool that determines if your jointer fence is 90° to the table, if the end of a board has been shot square or if a drawer's joints are correct.

While I love my combination square, it has worn a bit after 16 years of daily use to the point where I don't trust it for high-tolerance tasks. So this spring I purchased a 7" try square from Chris Vesper, an Australian precision tool-maker, and it is now my favorite square.

Each of Vesper's squares are individually calibrated on a device of his own

invention, and their accuracy is noted on each box. And while I appreciate an insane amount of accuracy (110 microns deviation – or less – over the entire blade), what really sold me on the tool was the swifty bit of metal in the corner of the handle.

This hinged piece of steel allows you to rest the tool on the edge of the board without supporting it with your hand. It just sits there. All by itself. Genius.

While many old squares had a similar feature, I've never seen one with such a high level of refinement – so much so that Vesper has a patent pending on the mechanism. The tab has just enough resistance so it doesn't swing like a loose tooth. But when you press



it to move it, the tab moves smoothly out of the way so you can take an accurate reading.

Vesper has tested a square's tab by moving it more than 500,000 times. After the test, the tab on that square moved crisply (I tried it myself). These tools aren't cheap – they start at \$165 and go up depending on the size (4", 7" or 10") and the handle you choose – but they are perfect. PWM

— Christopher Schwarz

Try Square

Vesper Tools ■ vespertools.com.au or
+61 (0)3 5977 8901

Street price ■ from \$165 to \$375

■ BLOG Read about a visit to Chris Vesper's shop in Australia.

Prices correct at time of publication.



THE NEW STANDARD



THE NEW 14" BANDSAW MODEL 10-321 IS EQUIPPED WITH A LARGE WORK TABLE MEASURING 15-3/4" X 20-3/8" WITH A 8" RE-SAWING CAPACITY AND 13-5/8" THROAT, WHICH WILL ALLOW THE USER TO CUT THICKER MATERIAL ON A COMPACT SAW. THE 1 HP MOTOR WITH TWO BLADE SPEEDS OF 1620 FT/MIN, 3340 FT/MIN PROVIDES AMPLE POWER FOR RE-SAWING AND CUTTING OTHER MATERIALS, SUCH AS NON-FERROUS METAL, PLASTIC COMPOSITE AND FOAM MATERIALS.



Table Tilts 46° Right, 10° Left.



Includes 2-1/2" & 4" Dust Ports



Balanced Thick Cast Aluminum Wheels

www.rikontools.com

RIKON

POWER TOOLS

CARD #42 or go to PWFREEINFO.COM

JUST ADD IMAGINATION!

CORE BENEFITS

- * High quality carvings made with ease at an affordable price.
- * The beginner can start making projects with only minimal computer skills while the professional can take advantage of the machines CNC router capability using CAD/CAM software.

Visit Oliver Machinery's NEW customer forum online at www.olivermachinery.boards.net



MODEL 1013

Maximum work piece dimension of 13" x 18" x 3".
iPicture software included!

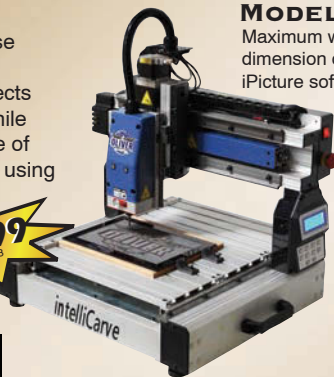

A TRADITION OF INNOVATION™

MODEL 1015 PRO

Work piece area of 15" x 20" x 4".
The 1015 PRO comes with i-Picture and ArtCam Express software.



Perfect for engraving signs, lithophanes, 3D carvings or intricate parts for projects.



Craft Ideas



Carving on wood, 1013 & 1015.

Now includes 500 sample images on CD!



3D carving on Corian 1015 only.



Wood carvings 1013 & 1015.

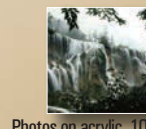

Photos on acrylic, 1013 & 1015.



Moulder Templates

WWW.OLIVERMACHINERY.NET | INFO@OLIVERMACHINERY.NET | 800-559-5065

OLIVERMACHINERY

WWW.FACEBOOK.COM/OLIVERMACHINERY

WWW.YOUTUBE.COM/OLIVERMACHINERY

CARD #94 or go to PWFREEINFO.COM

Train Your Eye

Good, better or best? Small details and design decisions make a difference.

It's every manufacturer's dream to have "one size fit all." Yet imagine a trip to the shoe store and upon arriving, you discover they offer only one size. We understand clearly that function is tied directly to size; a poor-fitting shoe is painful. Yet less obvious is how the "right fit" to our eye can affect aesthetics. We respond viscerally to something far off-kilter, but struggle with those small judgments that can make the difference between the good, the better and the best. That's at the heart of making design decisions. We search for that feeling of "rightness" for our own sake, and always in the back of our mind is the awareness that others will respond to it.

Cutting Through the Maze

That's where the rub comes in; trusting your inner eye and making design decisions seems like a big leap into the unknown. How do we learn to use our eye to guide the dozens of design choices required to make even a simple table? What shape do I make the top? Should I stain the wood and should the finish be glossy or satin? Obviously, each of these questions leads to a dozen more, and many must be weighed against function, cost and one's own skill.

Yet the design choices driven by function or need are not usually what we get hung up on. Roughing in those functional details, like making a table a comfortable height or adding a small drawer for your spouse's garden journal, is straightforward. The slippery questions arise as we search for that sense of rightness to our eye.



Details. Even something as small as the right-sized brass knobs can make a drawer design go from better to best. (The knobs pictured above are from Whitechapel.)

Simplify the Process

It would be great to make solid judgments naturally, but for most of us (myself included), it involves learning how to tap into an inherent sense of proportion and getting past all the clutter blocking the view. I use a thought process I call "good, better, best" (GGB) to help me get past the clutter.

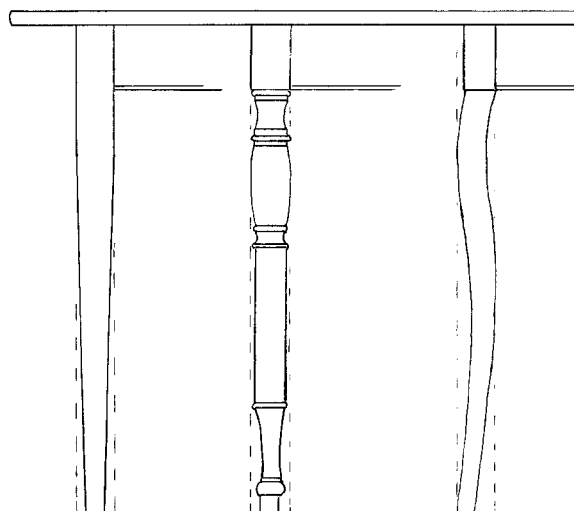

Proportions. Though different, each of these leg forms occupies the same proportional envelope. All must relate to the neighboring parts and to the whole.

In short, it's about breaking down a design into parts and gauging each element as it relates to parts closest to it, to the piece as a whole and to how it relates in its own internal details. GBB helps to quickly find a good solution and through refinements make it better, and then best.

Let's design a leg for a table as an example. Now our leg could be turned, rectilinear, a sculptural form or a combination of all of these. Any one of a thousand options could sing beautifully with that feeling of rightness—or strike a tone that misses the mark and falls flat. Regardless of the form, GBB involves testing how it relates to other parts of the design.

Application

Begin by comparing a range of different leg thicknesses and how the leg relates visually to the part closest to it, in this case the table apron. Rather than start with an arbitrary numerical dimension, begin with a

CONTINUED ON PAGE 20

The **EASIER** Way to
TRIM and **MOW** just
got *even better!*

The **NEW 2013**
Trimmer Mowers

- Now with wider 22" cut
- Lighter weight!
- Commercial quality Subaru Overhead Cam engines available

LOWEST PRICES EVER
with **FREE SHIPPING!**
FOR A LIMITED TIME

STARTING AT
\$399⁹⁹



6 MONTH HANDS-ON TRIAL

79368X © 2013

Call for a **FREE DVD and Catalog!**

TOLL-FREE
800-708-5249
DRtrimmer.com



INFINITY
CUTTING TOOLS

SUPER GENERAL™

10" x 40 Tooth Blade



Item: 010-044

On Sale Now!

- ✓ Perfect For Rip & Crosscuts
- ✓ Hard & Softwoods
- ✓ Laminates & Melamine
- ✓ Full & Thin Kerf Versions

Scan for Video



infinitytools.com | 877-USA-BITS

CARD #23 or go to PWFREINFO.COM

Bunk Bed Company
Creates Cash Flow
for Small Shops



1800BunkBed is a nationally recognized woodworking business with a 19-year proven track record. It offers a turnkey woodworking business, geared toward one-to-four-man shops. By using existing equipment and know-how, shop owners are able to create a reliable cash flow and eliminate slow times.

What started as a small backyard operation is now the nation's fastest growing woodworking business and the country's largest producer of custom bunk beds and loft beds.

Joining 1800BunkBed is quite affordable. Pricing is minimal and determined by population (currently averaging just \$285 per/month per territory) and a 1-time setup fee of only \$95.

1800BunkBed

It's Your Business!™

Visit
www.1800bunkbed.com/pw
for more information.

An A+ member of the Better Business Bureau and the U.S. Chamber of Commerce.

CARD #97 or go to PWFREINFO.COM

PRECISION
BUILT FOR
FINE WOOD
WORKING



Grex P6 Series
23 Gauge
Headless Pinners

The Invisible Fastener.
Up to 2" pins into Red Oak.



FIND YOUR DEALER

888-447-3926

647-236-3626

www.grexusa.com

CARD #20 or go to PWFREINFO.COM

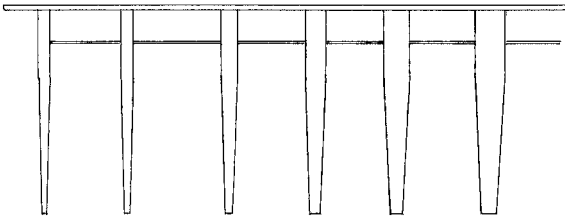

Relations. By focusing on the relationship between leg and apron, we can zero in on a sweet spot. Which leg thickness looks best to your eye?

proportion plucked from the design itself. You might take the leg thickness from the height of the apron; half the apron height is a good jumping-off place. I find it helpful to keep my eye tuned to proportional relationships.

Work up a sketch from that starting point then make a second sketch bumping the leg thickness a tad heavier. You might increase it by a fifth or a sixth of its thickness. Pause and consider how it relates to the apron. Does it look too heavy? Work up a sketch decreasing the leg. You may end up with five or six (or 20) versions.

As you begin to zero in on the thickness that relates to the apron, pause and compare the leg to the entire table. Letting your eye switch between the overall view and smaller view will help you discern if it needs further adjust-

ment. Your eye will naturally be drawn to the good, the better, then the best.

If you doubt your judgment, ask yourself at what point does the leg look obviously too thick or thin? Isolating elements using GBB forces your eye to make judgments between just two or three elements at one time rather than take random stabs in the dark. A design may progress from a scale drawing to a full-sized mockup before actual construction begins. The GBB logic applies to a mock-up just the same as to a drawing. By disciplining yourself to walk through this approach, you will find your eye quickly responding to more subtle adjustments.

Macro to Micro

Apply the same logic to small details internal to an element. For example,

'FINE POINTS OF FURNITURE'



The term "Good, Better, Best" goes back to a classic book on American furniture, "Fine Points of Furniture: Early American" by Albert Sack, that was first published in 1950. The book was reprinted 24 times before a revised edition titled "The New Fine Points of Furniture" was published in 1993.

Though written for the collector, this book has humble roots covered in sawdust and shellac. Albert's father, Israel Sack, was a cabinetmaker who emigrated from Lithuania to the United States in

1903. Finding work in a Boston furniture shop, Israel recognized that the best examples of American furniture rivaled anything from Europe, and he passed this love of American pieces on to his son, Albert.

"Fine Points" is a survey of the major forms of American furniture from the late 17th to early 19th centuries, with photos of different forms organized in terms of "Good, Better, Best." In the new edition, the categories of "Superior" and "Masterpiece" were added to indicate the highest levels of design and craftsmanship. This approach pays homage to a traditional way of training our judgment by observing excellence. The idea wasn't to encourage imitation, but rather to inform creativity.

—GW

drawer pulls are compared visually against the height of the drawer face. Every chamfer, bead, inlay and hardware detail can be sifted by your eye – thus the reason better hardware suppliers offer pulls and knobs in a wide array of sizes. The same logic drove wooden planemakers to offer dedicated moulding profiles in small increments. Every detail can be isolated by your eye, and narrowed down to GBB.

As your eye and confidence improve you may find yourself comparing in smaller increments, sorting through 20 curves to zero in on the best. This just means your eye is responding with a finer degree of discretion. Trust your eye; it won't lead you astray. **PWM**

George is the author of two design DVDs (Lie-Nielsen Toolworks) and co-author (with Jim Tolpin) of "By Hand & Eye" (Lost Art Press).



Choices. Beading planes come in different sizes so that an artisan can choose the "best" detail for a particular design.

ONLINE EXTRAS

For links to all these online extras, go to:

■ popularwoodworking.com/aug13

BLOG: Read more from George R. Walker on his Design Matters blog.

IN OUR STORE: George R. Walker's DVDs.

Our products are available online at:

■ ShopWoodworking.com

About This Column



Design Matters dives into the basics of proportions, forms, contrast and composition to give you the skill to tackle furniture design challenges with confidence.

HARBOR FREIGHT TOOLS

Quality Tools at Ridiculously Low Prices

LIFETIME WARRANTY
ON ALL HAND TOOLS!

FACTORY DIRECT TO YOU!

How does Harbor Freight Tools sell high quality tools at such ridiculously low prices? We buy direct from the factories who also supply other major brands and sell direct to you. It's just that simple! Come see for yourself at one of our 400+ Stores Nationwide and use this 20% Off Coupon on one of our 7,000 products*, plus pick up a Free 9 LED Aluminum Flashlight, a \$6.99 value. We stock Shop Equipment, Hand Tools, Tarps, Compressors, Air & Power Tools, Woodworking Tools, Welders, Tool Boxes, Generators, and much more.

- Over 20 Million Satisfied Customers!
- 1 Year Competitor's Low Price Guarantee
- No Hassle Return Policy!
- 100% Satisfaction Guaranteed!
- Over 400 Stores Nationwide

NOBODY BEATS OUR QUALITY, SERVICE AND PRICE!

FREE!
WITH MINIMUM PURCHASE OF \$9.99

3-1/2" SUPER BRIGHT NINE LED ALUMINUM FLASHLIGHT
ITEM 65020 shown
REG. PRICE \$6.99

LIMIT 1 - Only available with qualifying minimum purchase (excludes gift value). Coupon good at our stores or website or by phone. Cannot be used with other discount, coupon or prior purchase. Offer good while supplies last. Shipping & Handling charges may apply if not picked up in-store. Non-transferable. Original coupon must be presented. Valid through 10/25/13. Limit one coupon per customer per day.



20% OFF!
ANY SINGLE ITEM!

LIMIT 1 - Save 20% on any one item purchased at our stores or website or by phone. *Cannot be used with other discount, coupon, gift cards, Inside Track Club membership, extended service plans or on any of the following: compressors, generators, tool storage or carts, welders, floor jacks, Towable Ride-On Trencher (Item 65162), open box items, in-store event or parking lot sale items. Not valid on prior purchases after 30 days from original purchase date with original receipt. Non-transferable. Original coupon must be presented. Valid through 10/25/13. Limit one coupon per customer per day.



60" WORKBENCH WITH FOUR DRAWERS
WINDSOR DESIGN
LOT NO. 93454/69054/61488

\$139.99 REG. PRICE \$229.99

LIMIT 4 - Good at our stores or website or by phone. Cannot be used with other discount or coupon or prior purchases after 30 days from original purchase with original receipt. Offer good while supplies last. Non-transferable. Original coupon must be presented. Valid through 10/25/13. Limit one coupon per customer per day.



24" CLAMP AND CUT EDGE GUIDE
PITTSBURGH
LOT NO. 66126

\$6.99 REG. PRICE \$12.99

SAVE 46%

LIMIT 8 - Good at our stores or website or by phone. Cannot be used with other discount or coupon or prior purchases after 30 days from original purchase with original receipt. Offer good while supplies last. Non-transferable. Original coupon must be presented. Valid through 10/25/13. Limit one coupon per customer per day.



drillmaster ORBITAL PALM SANDER
LOT NO. 40070/61311

\$8.99 REG. PRICE \$21.99

SAVE 59%

LIMIT 9 - Good at our stores or website or by phone. Cannot be used with other discount or coupon or prior purchases after 30 days from original purchase with original receipt. Offer good while supplies last. Non-transferable. Original coupon must be presented. Valid through 10/25/13. Limit one coupon per customer per day.



12" x 33-3/8" WOOD LATHE WITH REVERSIBLE HEAD
CENTRAL MACHINERY
LOT NO. 34706

\$199.99 REG. PRICE \$349.99

SAVE \$150

LIMIT 3 - Good at our stores or website or by phone. Cannot be used with other discount or coupon or prior purchases after 30 days from original purchase with original receipt. Offer good while supplies last. Non-transferable. Original coupon must be presented. Valid through 10/25/13. Limit one coupon per customer per day.



5 SPEED DRILL PRESS
CENTRAL MACHINERY
LOT NO. 38119/44506/60238

\$49.99 REG. PRICE \$89.99

SAVE 44%

LIMIT 4 - Good at our stores or website or by phone. Cannot be used with other discount or coupon or prior purchases after 30 days from original purchase with original receipt. Offer good while supplies last. Non-transferable. Original coupon must be presented. Valid through 10/25/13. Limit one coupon per customer per day.



500 LB. CAPACITY ALUMINUM CARGO CARRIER
HaulMaster
LOT NO. 92655/69688/60771

\$69.99 REG. PRICE \$129.99

SAVE \$60

LIMIT 5 - Good at our stores or website or by phone. Cannot be used with other discount or coupon or prior purchases after 30 days from original purchase with original receipt. Offer good while supplies last. Non-transferable. Original coupon must be presented. Valid through 10/25/13. Limit one coupon per customer per day.



12" RATCHET BAR CLAMP/SPREADER
PITTSBURGH
LOT NO. 46807/68975/69221/69222

\$1.99 REG. PRICE \$5.99

SAVE 66%

LIMIT 7 - Good at our stores or website or by phone. Cannot be used with other discount or coupon or prior purchases after 30 days from original purchase with original receipt. Offer good while supplies last. Non-transferable. Original coupon must be presented. Valid through 10/25/13. Limit one coupon per customer per day.



WIRELESS DRIVEWAY ALERT SYSTEM
Bunker Hill Security
LOT NO. 93068/69590

\$12.99 REG. PRICE \$29.99

SAVE 56%

LIMIT 7 - Good at our stores or website or by phone. Cannot be used with other discount or coupon or prior purchases after 30 days from original purchase with original receipt. Offer good while supplies last. Non-transferable. Original coupon must be presented. Valid through 10/25/13. Limit one coupon per customer per day.



90 AMP FLUX WIRE WELDER
ELECTRO WELDING
LOT NO. 68887/61207

\$89.99 REG. PRICE \$149.99

SAVE \$60

LIMIT 4 - Good at our stores or website or by phone. Cannot be used with other discount or coupon or prior purchases after 30 days from original purchase with original receipt. Offer good while supplies last. Non-transferable. Original coupon must be presented. Valid through 10/25/13. Limit one coupon per customer per day.



HIGH SPEED METAL SAW
CENTRALPNEUMATIC
LOT NO. 91753/60568

\$9.99 REG. PRICE \$31.99

SAVE 68%

LIMIT 8 - Good at our stores or website or by phone. Cannot be used with other discount or coupon or prior purchases after 30 days from original purchase with original receipt. Offer good while supplies last. Non-transferable. Original coupon must be presented. Valid through 10/25/13. Limit one coupon per customer per day.



2.5 HP, 21 GALLON, 125 PSI VERTICAL AIR COMPRESSOR
CENTRALPNEUMATIC
LOT NO. 67847/69091/61454

\$149.99 REG. PRICE \$219.99

SAVE \$70

LIMIT 5 - Good at our stores or website or by phone. Cannot be used with other discount or coupon or prior purchases after 30 days from original purchase with original receipt. Offer good while supplies last. Non-transferable. Original coupon must be presented. Valid through 10/25/13. Limit one coupon per customer per day.



4 PIECE WOOD CHISEL SET
PITTSBURGH
LOT NO. 69471/42429

\$4.69 REG. PRICE \$7.99

SAVE 41%

LIMIT 7 - Good at our stores or website or by phone. Cannot be used with other discount or coupon or prior purchases after 30 days from original purchase with original receipt. Offer good while supplies last. Non-transferable. Original coupon must be presented. Valid through 10/25/13. Limit one coupon per customer per day.



1.5 TON ALUMINUM RACING JACK
PITTSBURGH
LOT NO. 68053/69525/60569

\$59.99 REG. PRICE \$119.99

SAVE \$60

LIMIT 4 - Good at our stores or website or by phone. Cannot be used with other discount or coupon or prior purchases after 30 days from original purchase with original receipt. Offer good while supplies last. Non-transferable. Original coupon must be presented. Valid through 10/25/13. Limit one coupon per customer per day.



44" 13 DRAWER INDUSTRIAL QUALITY ROLLER CABINET
US GENERAL MACHINERY
LOT NO. 68784/69387

\$359.99 REG. PRICE \$649.99

SAVE \$290

LIMIT 4 - Good at our stores or website or by phone. Cannot be used with other discount or coupon or prior purchases after 30 days from original purchase with original receipt. Offer good while supplies last. Non-transferable. Original coupon must be presented. Valid through 10/25/13. Limit one coupon per customer per day.



Order at HarborFreight.com or 800-423-2567
We FedEx Most Orders in 24 Hours for \$6.99

GRAND OPENINGS La Mirada, CA Vista, CA
Crest Hill, IL Madison Heights, MI Dallas, TX
Crystal Lake, IL St. Louis, MO Richmond, VA



Voysey Mantel Clock

BY ROBERT W. LANG

Build this sleek, contemporary-looking design from 1895.

Charles Francis Annesley Voysey (1857-1941) was one of the eminent architects and designers of the British Arts & Crafts movement of the late 19th and early 20th centuries. Voysey designed complete environments, including textile and wallpaper patterns. His work influenced American designers such as Harvey Ellis, who is also known for the use of architectural details in furniture designs.

The original drawings for this clock are dated 1895, and examples exist in various materials. The best-known of these clocks features a painted bucolic landscape, and a gilded dome and spire. There are also examples in wood, including ebony with ivory inlay and dark oak. There is even a version from 1903 made from aluminum.

For my version, I decided to use contrasting woods, with exotic materials for the inlay. The four legs, dome and spire are tiger maple and the panels and foot mouldings are ebonized walnut. The dots and ring on the face are mother-of-pearl, and the horizontal stripes on the legs are ebony.

Despite the sophisticated appearance of the clock, the case is simple construction: panels fit in stopped grooves in the legs. Where things get tricky is under the top, where the moulding

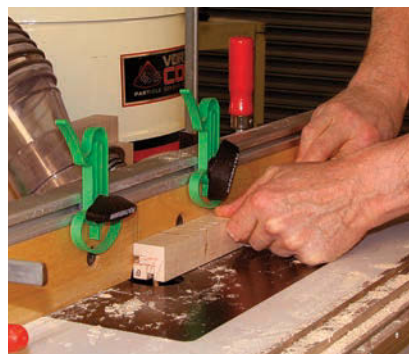

Right-side up. Making the grooves first makes it difficult to mix up the inside and outside of the legs.

steps in and out around the perimeter. The challenge is one of scale, and finding ways to make the process as simple as possible.

Thin Panels, Tapered Legs

I worked to the original 1895 drawing, and resawed the panels from 4/4 stock. I first made the panels $\frac{1}{16}$ " thicker than finished size and let them sit for a few days. I piled some scrap lumber on top to help keep them flat, then milled the front, back and sides to $\frac{1}{4}$ " thick and the top to $\frac{7}{32}$ " thick. I made the back panel $\frac{1}{4}$ " wider than the finished size to allow for two ribs for the back door.

While the panels acclimated, I went to work on the legs, feet and moulding.



Keep it simple. This jig takes only a few minutes to assemble, and provides a safe method to taper the legs at the table saw.

The legs were milled to $1\frac{1}{4}$ " square, and after deciding which piece of wood looked best in which position, I marked the tops with a cabinetmaker's triangle.

The sequence of tasks on the way from rough blank to finished leg isn't critical. I milled the grooves and cut the stub tenons on the bottoms before cutting the tapers on the outside faces. That – along with the cabinetmaker's triangle – made it easy for me to keep the parts properly oriented.

I set up a $\frac{1}{4}$ " straight bit in the router table, then set the fence and stop-block to make the $\frac{1}{4}$ "-deep grooves that are $\frac{9}{16}$ " from the inside faces and stop $13\frac{5}{16}$ " down from the top. That setting works for only one groove on the

four legs, so I reset the fence to make the second set of grooves.

With a $\frac{3}{8}$ "-wide dado stack in the table saw, I set a stop on the miter gauge to make the tenons. After cutting the tenons, I used a simple table saw jig to taper the legs to 1" square at the top, then planed away the saw marks. To complete the legs, use a chisel to square off the ends of the grooves.

Mouldings in Miniature

There are two mouldings used in this piece: a simple $\frac{1}{4}$ "-radius cove on the feet and a more complex profile used as a cornice under the top. Both of these are rather small, so I carefully ripped the rough material then brought the pieces to finished size with the planer. I made plenty of blanks about 24" long.

When thin mouldings are mentioned, someone will offer the advice to run the profile on wide pieces then rip the parts to their finished size. Sometimes this makes sense, but with this project it made more sense to me to be careful with the router table setup rather than stop after every pass to move to the table saw and jointer.

That gave me more control over the final size, and took far less time. The key to milling small parts is to use a setup that holds the parts in position as they are cut and keeps fingers out of harm's way.



Smooth sailing. A handplane quickly removes the machine marks from the columns and it leaves a flat, smooth surface.



First on edge. The first cut of the cornice moulding is made with the wood on edge.



Second on face. The final cut leaves the narrow edge at a uniform thickness.

The foot moulding is made with one pass and a $\frac{1}{4}$ "-radius cove bit, but the ogee moulding requires two setups with different cutters. The ogee is flattened out, so there isn't a standard cutter available that matches the profile. The first cut is made with the moulding on edge, using a portion of a vertical raised-panel bit (Lee Valley #16J63.54).

For the second cut, the material is laid flat to pass below a rounded-end grooving bit with a $\frac{1}{8}$ " radius (Lee Valley #16J42.01).

Make the Cut

There are lots of mitered corners in this project. See "Small Miter Setup" (below) for the two fixtures that I used.

SMALL MITER SETUP

One of the challenges of this project is making small miters accurately and efficiently. I made a small miter block to speed the process. Using a table saw or powered miter saw with pieces this small would be insane, but I did use a powered saw to cut a piece of scrap at 45°.

After gluing the three pieces of the miter block together, I clamped the 45° piece to the back fence of the fixture and used it to position my backsaw to make kerfs in the fence to guide the saw through the rest of the project.

I also built a small shooting board to use with my block plane. One piece of plywood serves as a base, and the smaller rectangular piece raises the work into the plane iron. The two narrow fences are aligned at 45° to the front edge and are held in place with glue and brads.

Shooting removes a very thin slice from the end of the workpiece. With a sharp plane iron and a bit of wax on the shooting board's base, it doesn't take long to get a feel for how to hold the wood against the plane and how to adjust the cuts for a good fit.

—RWL



Simple solution. This shop-made miter cutting block (raised to a comfortable height) makes quick work of cutting the numerous miters for this project.



Shoot to fit. This fixture holds the workpiece at the correct angle and guides the block plane to perfect the ends of the mitered pieces.

I began with the feet, and placed a leg tenon-side up in my vise for reference. I cut one piece of the moulding and when I was satisfied with the length, I made a pencil mark on the base of the miter block and proceeded to cut all 16 pieces of the foot moulding.

After cutting a few pieces, I glued them together in pairs, rubbed the joints and set the pairs aside to dry. With eight pairs completed, I checked the fit of two pairs against the tenon. To adjust the fit, I used my shooting board or, to remove just a tiny bit, rubbed both ends at once against sandpaper glued to scrap plywood. When I was happy with the fit, I glued each foot together. If the assembled foot mortise is a little

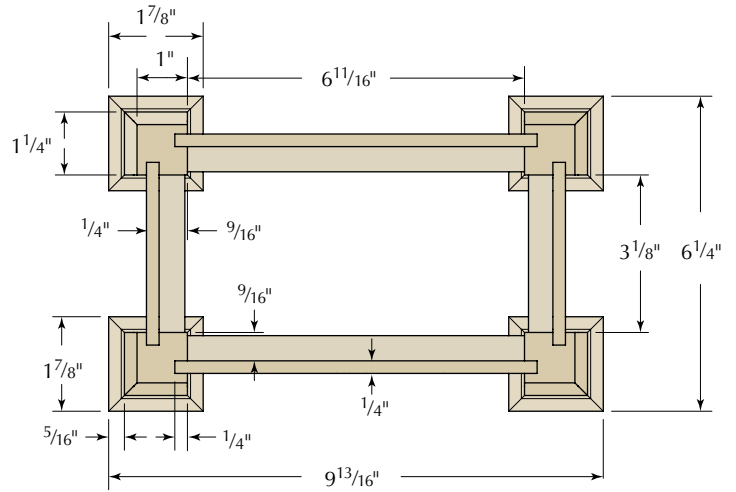

CARCASE PLAN

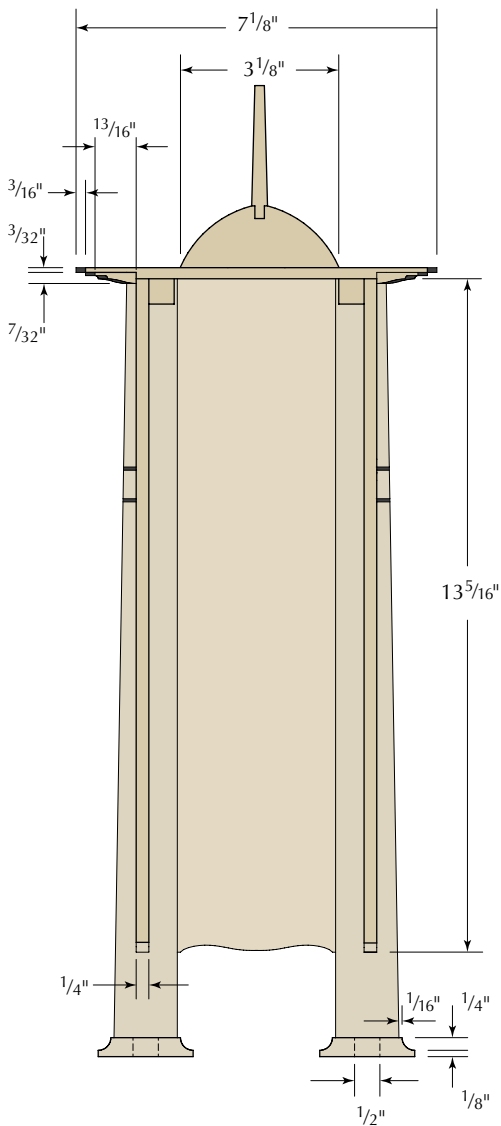

SECTION

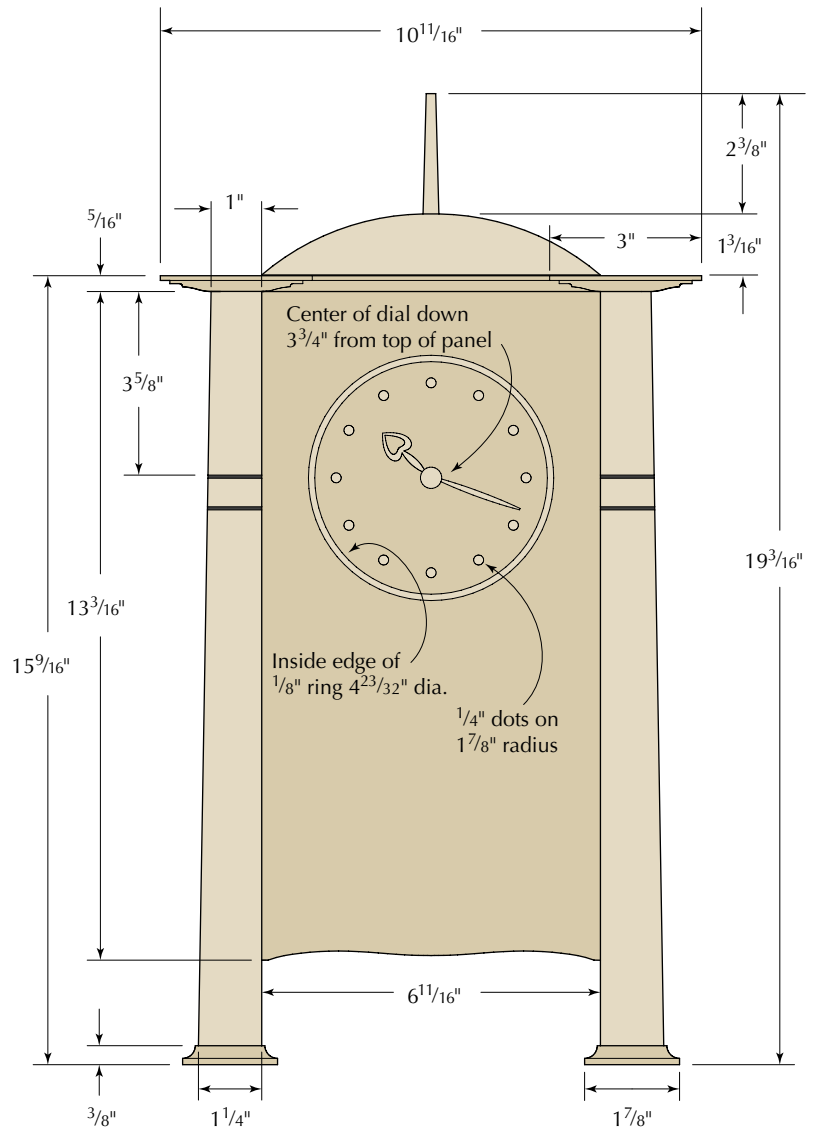

FRONT



Two easier than four. Each half of a foot is put together, then two pairs are assembled to fit the tenons on the ends of the legs.

small, the tenon or the inside of the assembled foot can be filed down.

A Little Off the Top

The top has indented notches, 3" in from each outside corner. It's a nice touch, but the detail that looks simple from above gets complicated down below. There really isn't a way to avoid running the cornice moulding as separate pieces that are mitered at the corners. I used a method that makes it relatively simple, albeit tedious.

The completed top is $\frac{5}{16}$ " thick, but Voysey's drawings don't detail how the top attaches to the case, or where the moulding ends and the top begins. It makes sense to run the legs and panels past the bottom edge of the moulding to allow them to cover the transition, yet reduce the thickness of the top.

The top is only $\frac{3}{32}$ " thick at the edge – too thin to be practical for the entire part. I realized that a wide rabbet around the perimeter of a thicker top would provide an edge to butt the moulding to as I fit and assembled.

I cut a piece of $\frac{1}{2}$ " plywood 2" smaller than the top, and cut a $\frac{3}{16}$ "-deep notch 1" in from each corner. Then I cut a second plywood rectangle $\frac{3}{8}$ " smaller than the first and attached it to the first piece, aligned with the ends of the $\frac{3}{16}$ " notches. I ran a router with a flush-trim bit between the notches to make a pattern the shape of the top, but offset in 1".

I planed the top to $\frac{7}{32}$ " thick and cut it to size, then cut a $\frac{3}{16}$ "-deep notch 3" in from each outside corner, and made a straight rip from notch to notch at the band saw. Using double-sided tape, I attached the pattern to the bottom of the top then headed to the router table. I installed a straight bit with a bearing above the cutter and set the height to leave $\frac{3}{32}$ " at the edge of the top.

It took several passes to cut the rabbet because the bit diameter is smaller than the width of the rabbet. I made the first pass as a climb-cut to create a nice edge without tear-out, bracing the piece against the router table fence to

"Never look at an ugly thing twice. It is fatally easy to get accustomed to corrupting influences."

—C.F.A. Voysey (1857-1941),
British architect & designer

keep it under control. The last pass was with the bearing against the template.

Multitude of Miters

With the top bottom-side up near my miter block, I began to fit the moulding to the inner notches. The rabbet made it easy to set one end against the inside corner so I could mark the other. With the four inside pieces cut, it was time to deal with the small return pieces.

I shot one end of each return piece, cut it to rough length and glued it to a long piece; by the time the last piece was cut and glued the first was dry. I then used the shooting board and block plane to trim to my pencil marks.

For each outside corner, I cut and assembled two pieces. The final assembly of the top's moulding was made easier by dealing with eight sub-assemblies instead of 20 individual pieces.

For Appearance's Sake

The inlays on the face are mother-of-pearl, available pre-cut from online suppliers to luthiers. The $\frac{1}{8}$ "-wide ring is made for the sound hole of a guitar, and the $\frac{1}{4}$ "-diameter dots are fingerboard markers. The location of the inlays is based on the clock face.

The inner diameter of the ring is 120mm, or slightly more than $4\frac{23}{32}$ ". I made a disc from $\frac{1}{2}$ " plywood, $\frac{1}{2}$ " smaller than that size, and attached it to the front panel with double-sided tape and a screw through the center and into my bench. With a $\frac{1}{8}$ "-diameter straight bit in a small plunge router with



Follow me. The pattern is made to the exact size of the perimeter rabbet. The bearing on the bit follows the pattern to make the cut.



Start inside. The rabbet provides exact locations for the cornice moulding. The first piece fits within the notch.



Slight return. The outside corners are used to mark the length of the moulding returns after the first miter is fit.

Voysey Mantel Clock

NO. ITEM	DIMENSIONS (INCHES)			MATERIAL
	T	W	L	
❑ 4 Legs	1 ¹ / ₄	1 ¹ / ₄	15 ¹ / ₄	Tiger maple
❑ 1 Front panel	1/4	7 ³ / ₁₆	13 ⁵ / ₁₆	Ebonized walnut
❑ 2 Side panels	1/4	3 ⁵ / ₈	13 ⁵ / ₁₆	Ebonized walnut
❑ 1 Back panel	1/4	7 ⁷ / ₁₆ *	13 ⁹ / ₁₆	Ebonized walnut
❑ 1 Foot moulding	3/8	9/16	48	Ebonized walnut
❑ 1 Top panel	7/32	7 ¹ / ₈	10 ¹¹ / ₁₆	Ebonized walnut
❑ 1 Top moulding	7/32	13/16	72	Ebonized walnut
❑ 1 Dome	1 ³ / ₁₆	3 ¹ / ₈	6 ¹¹ / ₁₆	Tiger maple**
❑ 1 Spire	5/16	5/16	2 ⁵ / ₈	Tiger maple†
❑ 16 Column inlays	1/8	3/8	1 ⁹ / ₁₆	Ebony
❑ 1 Hour hand	1/16	9/16	1 ⁹ / ₁₆	Tiger maple**
❑ 1 Minute hand	1/16	9/16	2 ¹ / ₄	Tiger maple**

*Larger than front panel to allow back door cutout; **Cut to pattern; †Tenon one end (1/4" long)

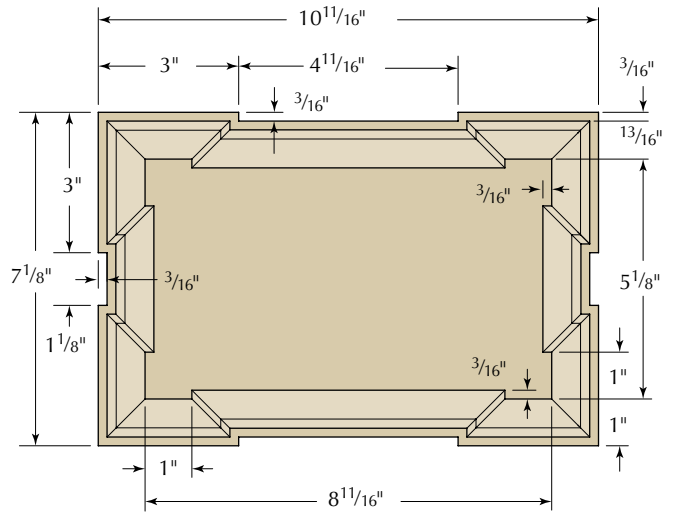

REFLECTED TOP PLAN

a 5/8"-diameter guide collar, I routed the recess for the ring.

The dots are laid out on a 3 3/4"-diameter circle. I drew vertical and horizontal centerlines, then drew the circle with my compass. That radius equals one-sixth of the circumference so I stepped off the location of half the dots from the intersection of the vertical centerline and the circle, and the other half from the horizontal centerline.

The shallow holes for the pre-cut dots are made with a Forstner bit at the drill press. I aimed to set the mother-of-pearl slightly below the surface of the wood. That is ideal, but it's not critical because the inlay can be sanded with common woodworking abrasives. Duco cement holds the inlays in place.

Around the Back

A small door on the back panel on the original accesses the clockworks; a small knob and wooden keeper hold it shut. I marked the location of the door, drew reference marks across the panel then made two rip cuts at the table saw to create the stiles. That was followed by two crosscuts to form the rails.

I installed the hinges on the door and the right-hand stile before gluing the panel back together. The hinges are tiny, so I made the gains for them by slicing the ends with a knife and "routing" the depth with my marking gauge.

At this point I made a test assembly,



Handle it. The smallest pieces are glued to longer ones to make it possible to hold them for trimming the ends to the exact length.



Happy ending. The outer corners are the last to be fit (and are the easiest to adjust) to complete the cornice moulding.



Take a turn. A plywood circle is used as a template for the router guide collar to follow when making the groove for the inlaid ring.



Drop in. The inlay materials were purchased as pre-cut parts from a luthier's supply store. These parts could also be fabricated from wood or other materials.



Perfect match. The back door is cut with four straight cuts from a single panel; the hinges are installed before reassembly.



One at a time. Each panel is fit to the top before attempting to fit the entire carcass. That makes it easy to find the troublemakers.



Hold on there. Square cleats glued to the bottom of the top capture the panels. Final assembly comes after the panels are ebonized and the columns are oiled.

fitting each panel between two legs and testing the fit on the inside of the top panel. I made a couple of adjustments as needed by planing the edges of the panels or scraping away the back of the moulding. When each panel fit individually, I assembled all four with the legs and made sure everything fit neatly within the moulding.

Four 1/2"-square cleats were cut from scrap to fit in between the legs; I simply

glued them to the top, taking care not to get any glue on the panels. I then took the case apart to make the dome and spire, and to inlay the horizontal bands on the legs.

The slots for the dark bands are made at the table saw. I raised the blade to match the distance from the outer edge of the groove to the face of the leg at the top band and made a cut across each of the tapered faces. The slot for the lower band needs to be slightly deeper, so I used the edge of a file to adjust the slot. The goal is to leave the bands barely proud of the show surface and trim them flush later.

These inlays are genuine ebony, as opposed to the ebonized walnut for the panels and moulding. The ebonizing solution reacts with the maple, so these inlays can't be stained after they are in place. I milled some ebony to match the width of the slots, and ripped them slightly wider than necessary. I mitered the outer corners and glued them in place, then trimmed them flush with my block plane after the glue was dry.

A Dome of Your Own

After printing a full-size drawing of the front and side arcs for the dome, I used spray adhesive to attach the paper to the dome blank. There is a small flat square at the top of the dome to mate with the bottom of the spire. I cut a

3/16"-square mortise with a drill bit and a square punch, about 1/4" deep.

Because the curves go entirely to the bottom edge of the dome, I temporarily attached a 1 1/2"-square block to the blank with double-sided tape. I made the vertical cut first, then used blue painter's tape to put the scraps back on the blank. Then I made the cuts in the other direction. The bulk of the saw marks were removed with rasps before finish-sanding the dome.

The spire starts as a 5/16"-square piece, and I used the full-size drawing to lay out the tapers and the teeny tenon. The shoulders of the tenon were cut with a backsaw, then I used a chisel to pare down the cheeks. The taper was made with a block plane.

Time on my Hands

The inexpensive quartz movement mounts to the clock at the center of the face. These movements are nice, but the metal hands that come with them are not—so I decided to make 1/16"-thick wood hands, and attach those to the standard-issue metal ones. Using the metal hands as a backing allowed me to easily mount the wooden ones.

My first attempt at cutting hands with the scrollsaw failed; the wood split at the heart-shaped cutout of the hour hand. I tried again, this time using three thicknesses glued in a stack with

SUPPLIES

Klockit

klockit.com or 800-556-2548

1 ■ Q-80 quartz clock movement
#10082, \$5.50

1 ■ flat hand
#66943, \$5.40

1 ■ sweep second hand
#68047, \$4.40

Duke Luthier

dukeluthier.com

1 ■ 120mm guitar rosette
#MOP 3mm rosette, \$9.95

Stewart-MacDonald
stewmac.com or 800-848-2273

12 ■ 1/4" pearl dots
#0011, \$.67 each

Lee Valley

leevalley.com or 800-871-8158

1 pair ■ 20mm x 13mm hinges
#00D30.04, \$1.40

Prices correct at time of publication.

contact cement. This survived the session at the scrollsaw, and after shaping the hands with a file, I separated the strips by pouring a little lacquer thinner on the edge of the stack.

After trimming the metal hands to size and roughing the surface with sandpaper, I epoxied the metal hands to the back of the wood ones, let the epoxy cure, then pared the circular end of the minute hand with a chisel to provide room for the nut to thread securely.

Color with Chemistry

Good old American walnut can be colored to a dramatic black with a homebrew solution. I put a pint of vinegar in a plastic cup, tossed in a ripped-up pad of steel wool and let that soak for a few days. (Gas forms as the acid in the vinegar works on the metal, so leave the container open; if you cap it, it can explode.) The liquid remains clear, but the metal starts to dissolve and scum forms on the surface. Before using the solution, strain it through a coffee filter into another container.

When you brush the liquid on the walnut, nothing happens at first. A chemical reaction between the tannins in the wood and the solution changes the color, and that takes a few minutes.



Nothing yet. The ebonizing solution won't change the color immediately. The chemical reaction between the rusty vinegar and the tannic acid in the wood takes a few minutes.



Inlay-safe. The solution has no effect on the mother-of-pearl inlay. Residue from coloring is removed with a non-woven abrasive pad, then the panel is ready for assembly.

When the wood dries out, there may be some residue on the surface. The rusty vinegar doesn't react with the mother-of-pearl, so I only needed to wipe off the sludge after coloring. I buffed the surfaces of the panels with a nylon abrasive pad to remove the residue and to smooth the surfaces.

The walnut may look more blue than black, but the application of clear shellac (or other clear finish) delivers a nice dark color. The figured maple on the legs is accented with a coat of clear Danish oil applied before final assembly.

My last step before putting the clock together permanently was to locate and drill two holes through the underside of the top and into the dome.

Together at Last

With the top upside down on the bench, I ran a bead of liquid hide glue down each groove, then put the panels in the grooves. I then ran a bead of glue in the corner where the cleats meet the top and set the assembled legs and panels in place.

After making sure that everything was in the right position and after gluing the spire into the dome, I left the parts to dry overnight. The following day, I flipped the assembly over and permanently attached the dome by

reaching in through the back door to drive the two screws.

The assembled clock was sprayed with four coats of clear shellac (on a small project such as this, you can use the stuff in the spray cans). After allowing the shellac to dry completely, I sanded the surface with #320-grit sandpaper, followed by an abrasive pad. A coat of satin lacquer, also from a spray can, completed the finish. **PWM**

Bob is executive editor of Popular Woodworking Magazine, and the author of several books about the Arts & Crafts period of the early 20th century.

ONLINE EXTRAS

For links to all online extras, go to:

■ popularwoodworking.com/aug13

BLOG: Read about an alternate method used to make the inlaid ring out of wood.

TO BUY: "Arts & Crafts Furniture Classics" is a compilation of Robert W. Lang's project articles from the pages of Popular Woodworking Magazine.

WEB SITE: See photos of the original Voysey clock at the Victoria & Albert Museum.

DOWNLOAD: Get full-size patterns of the panel bottoms, clock hands, dome and spire.

IN OUR STORE: Buy the video and watch the author build this project step by step.

Our products are available online at:

■ ShopWoodworking.com



One, two, three. Rasps remove the band saw marks, refine the shape and smooth the surface of the dome.

Carve a Classic *Linenfold Panel*

BY MARY MAY

Learn the techniques to carve this traditional flowing drapery design.

Backpacking across Europe as a college student, I experienced the awe-inspiring splendor of magnificent cathedrals and castles. I took every opportunity I could to visit these buildings, and I was afraid to blink for fear of missing some intricate and important detail; I just could not get enough. Without realizing it, this was the start of my passion and love for the art of woodcarving.

The walls in these splendid buildings were often covered in carved oak panels with a flowing drapery design that are referred to as “linenfold panels” or “parchment folds.” This design fascinated me as I studied how the delicately carved ends gave the appearance of cloth that gently twisted and folded over itself. Even without experience in carving, I appreciated the challenge in creating this flowing illusion in wood.

The linenfold panel imitates draped altar cloths and was introduced in panel decoration during the last quarter of the 15th century in the early Gothic period; it’s often seen combined as multiples in larger, paneled walls or in doors. Individual panels sometimes have their edges tapered to fit into grooves in furniture, walls or door frames.

The process of creating the linenfold shape offers many challenges. It is an



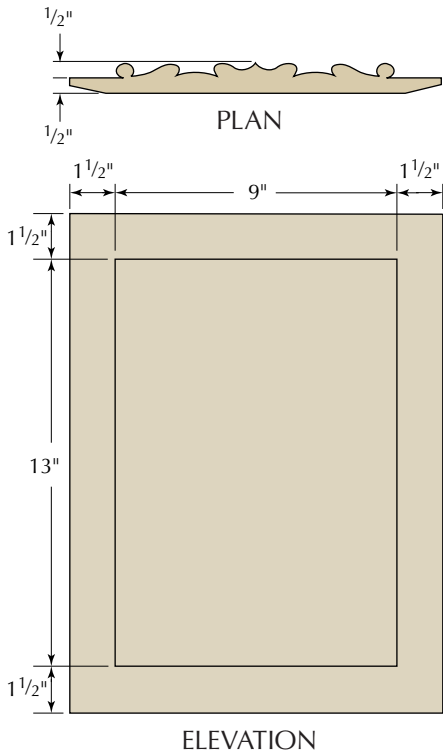

excellent project that teaches how to give the illusion of perspective in shallow relief.

Work in Large Scale

One suggestion as you learn to carve this design is to make a small section of the design on a larger scale. Carving the S-curve section helps you figure out some of the common problems that come up. It can be a real brain tease, but once you figure out how to achieve the illusion of flowing and twisting cloth, linenfold is a wonderful and satisfying accomplishment.

Who knows – you may get so encouraged, you'll decorate your own walls with it! If you do, call me... I'll give you some pointers. **PWM**

As a professional woodcarver with a workshop in Charleston, S.C., Mary offers classes in her shop and at a variety of other locations. She also offers instructional DVDs as well as an online video woodcarving school. Find out more at marymaycarving.com.

"By all means read what the experts have to say. Just don't let it get in the way of your woodworking."

—John Brown (1932-2008)
Welsh Stick Chairmaker

PREPARE THE PANEL

While the delicate carved details on the ends of the linenfold design demand precise carving abilities, lowering the background and preparing the curved profile of the panel requires an equal amount of skill using handplanes. Professional furniture maker Dan Hamilton, of Beaufort, S.C., demonstrates the techniques he used to prepare the wood for me on this project. This panel is made of walnut. —MM



Draw a depth line. Draw a gauge line to locate the depth to which the panel edge is planed. The depth of this particular design is 1/2".



Lower the cross-grain edge. With a moving fillister plane, remove the cross-grain waste just short of the 1/2" depth, so any spelching can be removed when the long-grain waste is removed. The skewed blade of the fillister plane is great for hogging away waste quickly. Next, clean down to the gauge line using a rabbet plane set to take a fine cut.

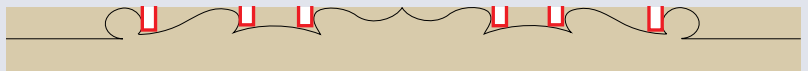

Draw the profile. Draw the profile of the linenfold design on the ends of the panel to locate the position of the folds in the cloth. Use a plow plane to remove wood between the folds. Set the plane's fence based on the linenfold pattern drawn on the edge of the wood. (These cuts can also be made at a table saw.) Make sure you do not cut them too deep; they should be just short of the background.



Lower the long-grain edge. When all the grooves between the folds are completed, use a fillister plane to bring down the two long edges to just short of the 1/2" depth. At this time any spelching or splintering from the cross-grain rabbet work is planed away. Next, clean down to the depth of the gauge line with a fine-set rabbet plane to leave a smooth surface.



Form the profile. Use a large hollow moulding plane to create convex areas in the panel. Concave areas can be shaped using round planes, and some areas can be worked with a block plane to fair the surfaces together. You can also use various carving gouges to touch up and shape these profiles.

TIPS FOR CARVING

Much of the carving on the edge of the linenfold design is an optical illusion. Viewing the panel from straight on should give the illusion of depth in a minimal thickness of wood. The most critical line in this design is the flowing edge of the cloth. When carving this, there are a few rules to keep in mind:

- Do not let any part of this line become straight; keep the edge flowing gently in a continuous curve.
- Do not let any break or separation appear along this curved line.
- Make sure that when you carve down the background sections, there is no visible step or transition where it joins the background that was lowered with the handplanes.
- The S shapes on the fold should not have any sharp corners, but should flow gently.

- One option, not mentioned in the step-by-step instructions, is to make the vertical stop-cuts at a slight undercut angle; the edge will create a dramatic shadow line. Be careful not to make these undercuts at too much of an angle or the edges will become too fragile. —MM

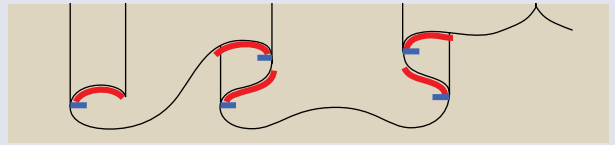

Use a vertical stop-cut to define the edges. This is where this carving often goes wrong. Make sure that when you make these vertical stop-cuts directly on the lines (shown in red), you do not let the gouges cross or extend over the curved edge of the fold because this would cause a break in the edge of the linenfold. Stop this cut just inside this edge (at the blue line).

1 Draw the linenfold profile on the top surface of the wood. Make sure that the lines go completely to the edges of the curved profiles.



2 Use a 6mm V-chisel to make a cut at the edge of the linenfold just below the line, leaving the line visible. Go as deep as the chisel can safely go, approximately $\frac{3}{16}$ ". This cut begins to remove the bulk of the wood and starts to shape the cloth edge.

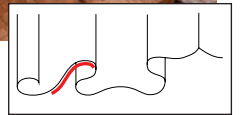

3 Use a 14mm No. 1 flat chisel and 14mm No. 2 gouge to define the edge of the linenfold where the background will be lowered. Make this a vertical stop-cut directly on the line and cut it all the way to the background.



4 Use a 6mm No. 3 gouge to flatten the background and clean up this triangle-shaped area. This section should finish at the same depth as the edges of the panel and should blend smoothly into this background.

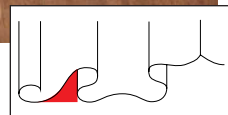

5 Using a 12mm No. 4 gouge, round this corner down to the background then clean up the background surface.

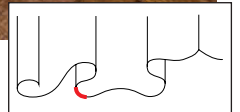



6 With a 6mm V-chisel, make a cut to define the middle twist in the cloth, and leave the line visible. Make this cut approximately $\frac{3}{16}$ " deep.

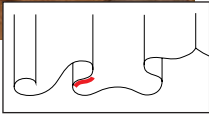

7 Use a 12mm No. 4 gouge and a 6mm No. 8 gouge to define the edge of the twist with a vertical stop-cut directly on the line. Make sure this cut does not go over the curved edge or it will break the continuous flow. This cut should go only to the depth of the lower twist (approximately $\frac{3}{16}$ " deep).

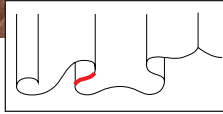

8 With a 6mm No. 8 gouge, hollow out this lower folded section. Make sure this flows smoothly into the next section of the cloth (that was shaped using a round moulding plane).

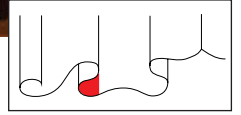

9 With a 12mm No. 4 gouge and a 6mm No. 8 gouge, define the top curve of the fold with a vertical stop-cut to the depth of the middle twist ($\frac{3}{16}$ "). Make sure it does not go over the curved edge, or it will break the continuous linenfold edge.



10 Using a 6mm No. 8 gouge, hollow out the upper section of the fold.

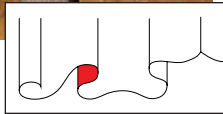

11 With a 6mm V-chisel, make a cut along the edge of the curl at the end of the cloth, leaving the line visible.

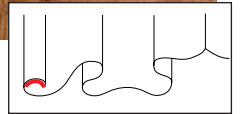

12 With a 6mm No. 8 gouge, make a vertical cut directly on this line to define the twisting edge. Again, leave this cut just short of the background and make sure it does not go beyond the curved edge to preserve the continuous linenfold edge.

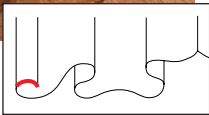

13 With a 6mm No. 8 gouge, carve out the section under this curved edge so it gently flows into the rest of the fold.

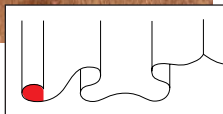

14 Use a 12mm No. 4 gouge to round off the outside corner with a vertical cut down to the background. Clean up the background surface.

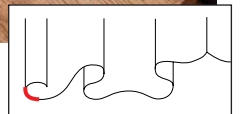



15 With a 12mm No. 4 gouge, make

a vertical cut on this line all the way to the background. Be careful not to let any of this edge become a straight line.

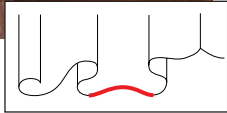

16 With a 14mm No. 3 gouge, lower this

section to the background.

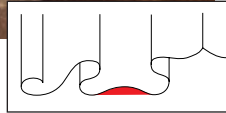

17 Use a 6mm V-chisel to

carve along the edge of the cloth, leaving the line visible. Make this cut as deep as the chisel will cleanly cut; this is to remove the bulk of the wood to prepare for the vertical stop-cut as shown in step 19 (below).

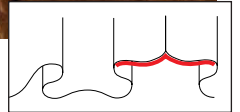

TOOLS YOU NEED

German-, Swiss- and Austrian-made tools are generally quality examples. Long-handled gouges are safer and easier to control than palm gouges. The “No.” in the list below refers to “sweep” – as the number increases, so does the blade curvature:

- Moving fillister plane
- Rabbet plane
- Plow plane or saw
- Various hollow and round Planes
- Mallet
- 6mm V-chisel (60° angle)
- 6mm No. 3 gouge
- 14mm No. 3 gouge
- 12mm No. 4 gouge
- 6mm No. 8 gouge

All of the woodcarving gouges that I have used in this instruction are fishtail shaped, because they reach into tight corners more easily.

Other techniques and tools can be used, such as using a table saw to lower the outside edges.

—MM



18 With a 6mm V-chisel,

carve along these straight edges of the fold.

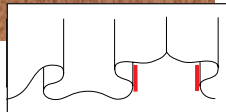

19 Pare with a 12mm No. 4 gouge and 6mm

No. 8 gouge held vertically to define this edge of the cloth.

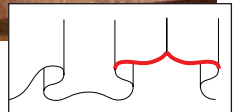

20 With a 14mm No. 3 gouge,

lower this section to the background.

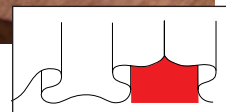

21 With a 12mm No. 4 gouge,

round the two corners with a vertical cut to the background, then clean up the background surface.

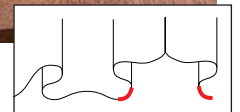

A CARVED ROOM

The carved entryway in the library of Meadow Brook Hall in Rochester, Mich., (right) is a stunning example of linenfold carving.

The linenfold design I chose to carve for this project is based on the wall panel details (below) of this historic house. It can be seen in the room known as “Alfred’s Study.”

— MM

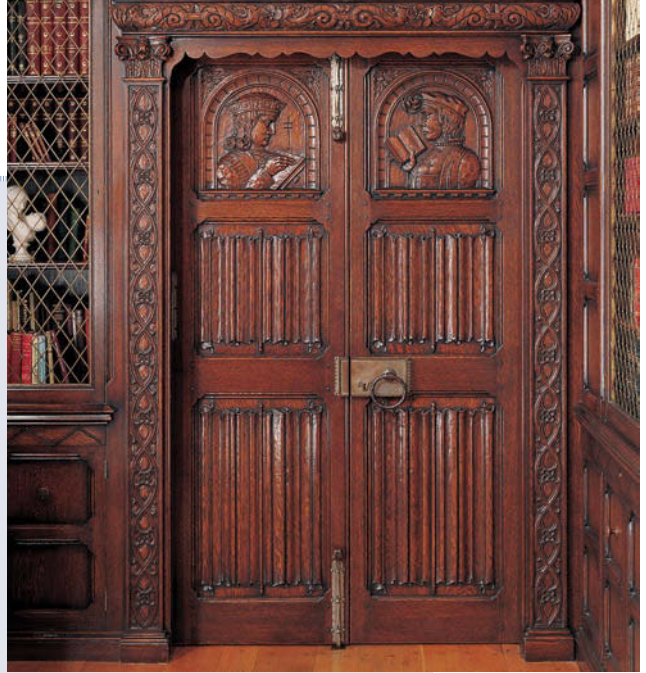

22 With a 6mm V-chisel,

make a cut to define the middle twist in the cloth, leaving the line visible. Make this cut approximately $\frac{3}{16}$ " deep.

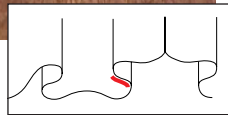

23 Use a 12mm No. 4

gouge and a 6mm No. 8 gouge to define the edge of the twist with a vertical stop-cut directly on the line. Make sure to not go over the curved edge or it breaks the continuous linenfold edge. This cut goes the depth of the lower twist (approximately $\frac{3}{16}$ "), not all the way to the background.

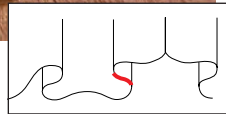

24 With a 6mm No. 8 gouge,

hollow this section so it gives the appearance of flowing cloth. Flow this cut into the area that was shaped with the hollow moulding plane.

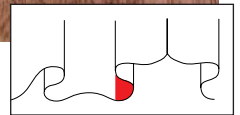

25 Using a 12mm No. 4

gouge and 6mm No. 8 gouge, make a vertical cut at the top curve of the fold to the depth of the middle twist (not shown), similar to step 9. With a 6mm No. 8 gouge, hollow this section of the fold.

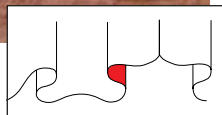

26 Use a 6mm No. 3

gouge to make a final 45° cut along the edge. This cleans up any rough edge and creates a nice shadow line.

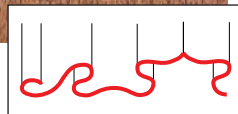

ONLINE EXTRAS

For links to all online extras, go to:

■ popularwoodworking.com/aug13

PATTERN: Download a free, full-size pattern of the linenfold design the author used to carve the panel in this article.

WEB SITE: Visit Mary May’s site for information on classes and to view a gallery of her work.

BLOG: Learn more about linenfold carving as you watch the author work on her panel.

TO BUY: Master the techniques to make 17th-century New England S-scroll carvings.

IN OUR STORE: DVDs and online classes in carving detailed acanthus leaf and shell carvings with master carver Mary May.

Our products are available online at:

■ ShopWoodworking.com

Take a U-turn to Scoop

BY MARIO RODRIGUEZ

A table saw and a simple jig make a time-consuming task quick and easy.



Woodworkers use all sorts of techniques to scoop out their chair seats. Many commonly resort to hacking out the waste with traditional tools such as an adze, travisher and scorp. Others design and assemble elaborate jigs to precisely guide and control a router. Some take the high-tech route and employ CNC equipment. But no woodworkers I know would turn to their table saws to get this tricky job done.

About 20 years ago I stumbled onto a unique scooping method in a self-published book by Robert Marquis titled, "Making the Classic Windsor Chair." As a chairmaker, I browsed the book and was intrigued by one technique that the author used that was radical, imaginative and maybe even daring. Marquis used the table saw to cut a shallow but symmetrical hollow in his seat blanks. His technique yielded results that were flatter, less sculpted and had a machine-cut quality. Because I was making more traditional chair styles then, I shelved the book and didn't give it much thought for the next 20 years.

Later I became interested in mid-century furniture designs, particu-

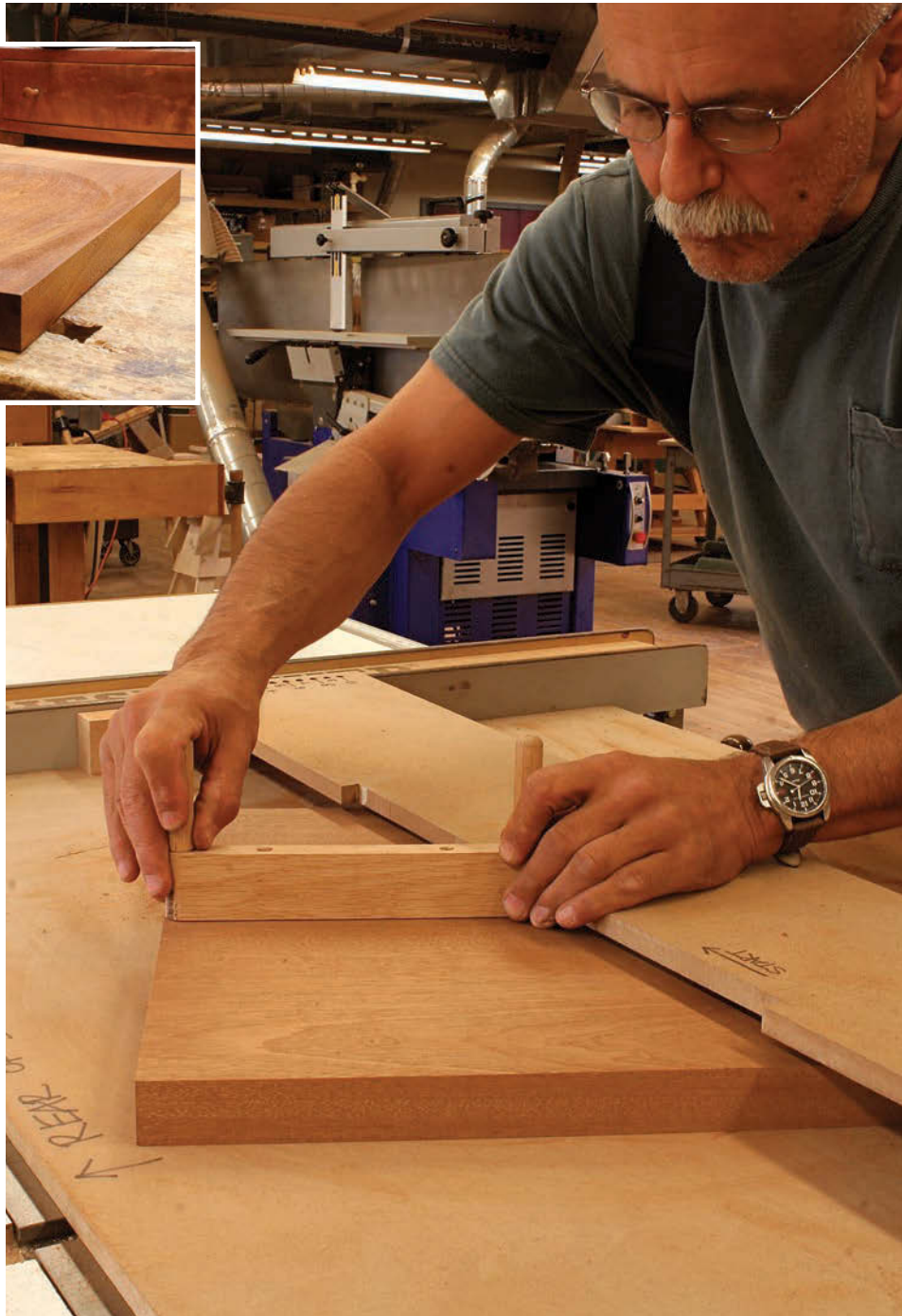

One big scoop. With a simple, shop-made jig, a table saw can make quick work of scooping a chair seat.

Top a Chair Seat

larly Scandinavian chairs, and recalled Marquis' unusual method. I was so skeptical of the technique that I consulted a candidate for a doctorate in engineering before attempting it myself. With a green light from the engineer, I constructed the necessary jigs and prepared a couple of seat blanks.

Cove Cuts on Steroids

Most woodworkers are familiar with cove mouldings cut using a table saw. You pass material along its length, guided by a fence, diagonally across a raised table saw blade to produce a cove cut. Well, the seat-scooping technique is a variation on that.

Using a jig to guide the work, you pass the material across the raised table saw blade, stop at a given distance, then make a U-turn and return to the starting point. Successive passes expand the width of the scoop. The depth of the scoop is determined by the height setting of the blade. I usually cut to a depth of $\frac{1}{4}$ ".

The jigs and technique that follow show you how to cut an attractive scoop that measures approximately $14\frac{1}{2}$ " long x $14\frac{1}{2}$ " wide. Both the width and the front-to-back dimensions are reached as cuts are made along the 16" travel groove, and as the bridge portion of the jig is moved forward on successive passes. Each pass increases both measurements of the seat's scoop.

First Make the Jig

There are seven relatively simple pieces that make up the jig needed for this technique. All of them can be built in the shop using common materials you probably already have on hand.

Let's start with the jig's base that clamps to the table saw and supports the entire operation. My base is made from MDF and

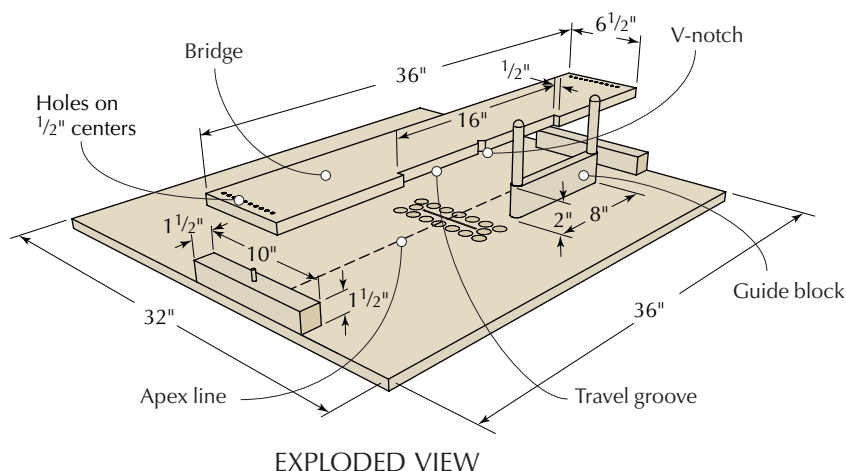

Chair Seat Scooping Jig

NO.	ITEM	DIMENSIONS (INCHES)			MATERIAL
		T	W	L	
1	Base	$\frac{3}{4}$	36	32	MDF
2	Bridge supports	$1\frac{1}{2}$	$1\frac{1}{2}$	10	Hardwood
1	Bridge	$\frac{3}{4}$	$6\frac{1}{2}$	36	MDF
1	Guide block	$\frac{3}{4}$	2	8	Hardwood
2	Guide-block handles	$\frac{1}{2}$ dia.		$4\frac{3}{4}$	Hardwood

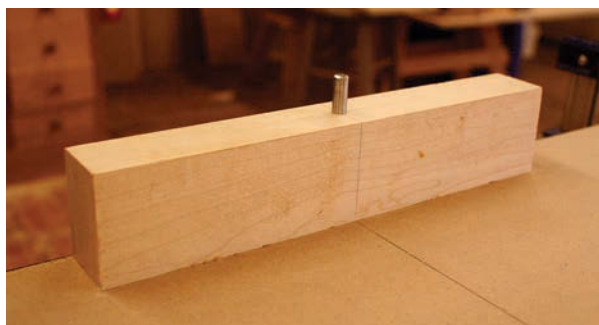

Bridge abutments. Support blocks elevate the bridge and provide space for the seat blank. The indexing pins are used with the holes at the each end of the bridge.



Heart of the jig. The bridge is central to the scooping operation. Its travel groove controls the path of the seat blank and the V-notch (inset) is the pivot point for making the U-turn.

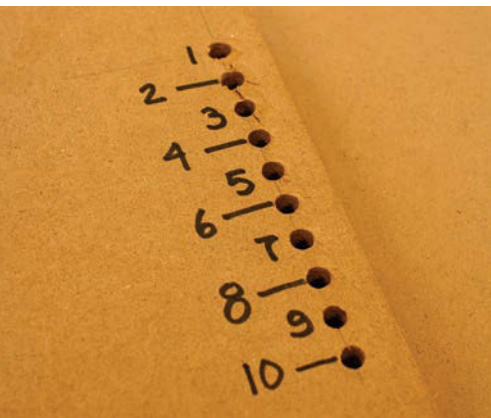

Bridge indexing. Both ends of the bridge have $\frac{1}{4}$ " holes set on $\frac{1}{2}$ " centers that are used to position the bridge on the support pins.

is 36" wide x 32" deep (you may need to alter the size to fit your saw).

With the blade all the way down, secure the MDF to the saw. Start the saw and slowly raise the blade through the base about $\frac{3}{8}$ " above the MDF. Remove the base and drill a series of $\frac{1}{2}$ "-diameter holes around the saw cut to facilitate sawdust collection. Based on the location of the saw cut, draw a line perpendicular to the apex of the saw blade's height.

Next, make and install the two bridge support blocks. (These blocks should hold the bridge high enough to clear the thickness of the seat blank as it travels between the bridge and the base.) In the center of the top edge of the blocks, drill a $\frac{1}{4}$ "-diameter hole and tap a $\frac{1}{4}$ " steel pin into each block. (Leave about $\frac{3}{4}$ " of the pin above the block.) Carefully install the blocks on the jig base so the center of the pin aligns with your apex line (see the drawing on page 37).

Build a Bridge

The bridge is a critical part of the jig. It controls the width and length of the scoop (the depth is controlled by the height of the saw blade). The bridge extends across the table saw and is approximately $6\frac{1}{2}$ " wide and as long as the width of your jig's base. Centered along its length is a $\frac{1}{2}$ "-deep x 16"-long cutout that I call the "travel groove." Centered on the travel groove is a $\frac{3}{8}$ "-wide V-notch. At each end of the bridge is a series of 10 $\frac{1}{4}$ "-diameter

HERE'S THE SCOOP

Scooping a chair with this table saw jig isn't as scary as it may seem at first glance. Sure, I was a bit nervous when I first used it – but I quickly learned it really is a safe operation. Best of all, the result is a crisply carved chair seat that is done in little time and requires a minimal amount of sanding. I usually spend no more than 10 to 15 minutes cleaning up the seat blank after the scooping is done. You might wonder what saw blade to use. In my shop, I use a standard combination blade.

Here are the steps to carve seat blanks using the jig:

1. Remove the table saw throat plate to improve dust collection. Clamp the jig base to the saw and raise the blade to $\frac{1}{8}$ " above the base.
2. Attach the guide block to the underside of the seat blank. It should be screwed down at the front edge of the seat and centered on its width.



Get ready. To prepare for scooping, clamp the jig securely to the table saw then raise the saw blade to $\frac{1}{8}$ " above the base of the jig.



Hold on to your seat. The guide block is secured to the underside of the seat blank. It's held at the front edge and centered from side to side.



Bridge ahead. Place the bridge on the support blocks with the indexing pins in the No. 1 bridge holes.

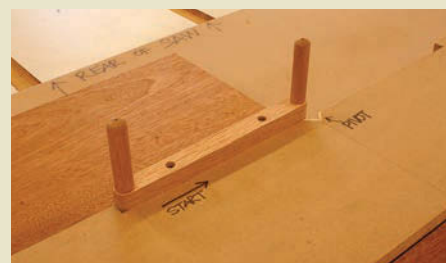

In position. With the guide block placed against the left-hand stop of the travel groove, everything is ready to begin the first pass of the scoop.

holes, spaced $\frac{1}{2}$ " from center to center. These holes must be spaced side to side so that the bridge will drop onto the $\frac{1}{4}$ " pins in the bridge support blocks.

Make the Guide Block

The guide block is screwed to the underside of your seat blank and slides along the travel groove in the bridge. It also provides handles for pushing the seat blank along, and is used to make the pivot motion in the V-notch of the travel groove. It is this pivot



Get a handle. The guide block attaches to the bottom of the seat and controls the blank's travel along the bridge. Dowels serve as handles.



Pivot point. Once the guide block reaches the right stop, it is pivoted in the V-notch in a counterclockwise rotation. After the pivot, the guide block is pushed to the right travel stop to complete the first pass.

3. Place the bridge on the bridge support blocks. Engage both the right (R) and left (L) holes marked "1" on the bridge with the steel pins on the bridge support blocks.
4. Place the seat blank upside down on the jig base. About half of the blank will be under the bridge. The blank should be positioned to the left of the saw blade with the front edge of the seat facing to the right. Align the guide block with the left stop of the 16"-long travel groove in the bridge.
5. Start the saw and with the blade spinning, carefully and slowly move the guide block along the travel groove from left to right until it reaches the right stop of the travel groove. This places the opposite end of the guide block at the centered V-notch.
6. Slowly and carefully engage the end of the guide block in the V-notch by turning the guide block in a counterclockwise direction. Rotate the block and seat blank 180°, making a complete U-turn.
7. With the front edge of the seat now facing left, continue moving the guide block along the travel groove back to the right stop. The first pass is complete.
8. Raise the blade to establish the full depth of cut (1/4") and repeat the process. For a seat such as mine, the 1/4" blade height will be all the depth needed. You can leave the blade set here for the rest of the scooping process because each successive pass now makes a slight cut, expanding the width of the previous pass.



Round trip. After the first pass is made, the saw blade is raised to 1/4" and the process is repeated. The result is a clean scoop.

9. With the left side of the bridge still engaged in hole 1 L, move the right side of the bridge to hole 2 R and repeat the cutting operation.
10. Now move the bridge to holes 2 L and 2 R and repeat the operation again. Then move the bridge to holes 3 L and 2 R. By advancing the bridge in this staggered progression to higher-numbered holes (up to 10), the width of the saddling is increased.

During the scooping process, interrupt the operation periodically to clear accumulating dust from the jig base as needed.

The saddled seat will be mildly scarred by saw blade marks. These are easily and quickly removed with sandpaper or a card scraper once the blank has been completely scooped. —MR



Clean up. After the series of passes are made, the seat is fully scooped. The blank is then sanded or scraped to remove any milling marks.

that swings the blank 180° to finish its trip along the travel groove. Make the guide block taller than the top edge of the travel groove when the guide is mounted to the bottom of seat blank (2" in this example).

At each end of the block are dowels used for handles. These handles need to extend at least 1 1/2" above the block — long enough to provide a secure grip for the operator while guiding the seat blank along the bridge's travel groove. The guide block is mounted perpen-

dicular to and flush with the front edge of the seat blank, and it's centered side to side.

That's all there is to the jig, and it's one you can use over and over as long as your seat blank thickness fits between the jig base and bridge. Step up to your saw. You're ready to start scooping seats the quick and easy way. **PWM**

Mario has made custom furniture for more than 30 years and also teaches at the Philadelphia Furniture Workshop (philadelphiafurnitureworkshop.com).

ONLINE EXTRAS

For links to all online extras, go to:

■ popularwoodworking.com/aug13

BLOG: Watch a short video in which Mario Rodriguez put his jig through its paces.

WEB SITE: Take a tour of the author's shop and school, Philadelphia Furniture Workshop.

IN OUR STORE: Order our full-length DVD "Table Saw Jigs & Fixtures."

Our products are available online at:

■ ShopWoodworking.com



William & Mary Spice Chest

BY ZACHARY DILLINGER

Curved stretchers, turned legs and hidden drawers make this piece a standout.

In the early 18th century, the fashionable place to store household spices was in an attractive, lockable spice chest. These chests were status symbols, because having one indicated your household was wealthy enough to require an entire chest to store these luxuries. This chest was inspired by a circa-1720 William & Mary Philadelphia piece; I used period techniques and tools to build it. And while we no longer treat household spices as valuables, the chest provides handsome storage in my modern household.

If you build this piece the way I did, you'll learn hammer veneering, hand dovetailing and how to cut curved shapes with straight tools. Perhaps most important, you'll learn to be organized in your project planning. A piece this small (18½" x 25⅞") with so many similar parts forces you to stay organized.

Case Construction

To begin, process your case sides and top to size and thickness. If you're working by hand, the reference edge for the sides, top and bottom should be the front edge. The reference face—that is, where all the joinery is laid out—is the inside of the case; that's where flat counts. The bottom for the top case is a glue-up with the front 2" of primary wood (in my case, walnut); the remainder is secondary wood (I used pine).

Once you have your sides to size, use a marking gauge to scribe the rabbet for the back.

The drawer dividers fit into dados. (On a larger case piece, it's good practice to use sliding dovetails for the drawer dividers rather than dados because the sliding dovetail is stronger, but for a case this small that's overkill—not to mention dados are much easier to cut.)

My dado locations were taken off a photo, so I laid out the centers of each divider using a compass. You have a plan from which to work so you can use a rule instead (see "Front View" on page 42). I then used a chisel to mark the shoulders. This is best done by clamping your sides together and marking out all the dados on both sides at the same time. Use a square and knife to mark

the shoulders across the grain on the inside face, then scribe the 1/4" depth of the dado with a marking gauge.

I don't have a good 3/8" dado plane, so to cut the dados I clamp a straightedge on the shoulders to serve as a fence to guide my backsaw. Once the edges are cut, use a chisel to remove only half of the waste, working in toward the center of the board from the front edge.

Now use a moving fillister plane to cut the 1/4" x 1/4" rabbets for the back in all four of the case pieces, then finish chiseling the dados the rest of the way across the panel, this time working in toward the center from the rabbeted side. Cutting the joinery in this order prevents blowing out the edges of the workpiece, and it allows you to use the rabbet to guide the chisel when removing the dado waste to final depth.

Once the rabbets and dados are cut, the case is ready to be dovetailed together. The through-dovetails at the case bottom are covered by the waist moulding; the half-blind dovetails at the top are covered by the cornice (the top cove moulding). This means that no unsightly end grain appears when the piece is finished. (This is important in most 18th-century work, when exposed end grain was not celebrated and was seen as a distraction from the overall design.) In all four corners of the case, the sides are the tail boards.

For a large case piece it makes sense to have the case sides be the pin boards because this helps to prevent the joinery from failing when under stress. For this small piece, there is little concern with this, so putting the tails on the sides allows you to gang-cut the tails. Once your joinery fits properly, glue the case together.

Drawer Dividers & Mouldings

For the drawer dividers, glue a 1"-wide piece of 3/8"-thick primary wood to a 7"-wide x 3/8"-thick piece of secondary wood. (The widest dividers finish at 7 3/4"; you may choose to glue up several panels for this purpose, given the different widths of the dividers as noted on the cutlist.) Crosscut this joined piece to the lengths provided in the cutlist, allowing a little extra length

on each so that you can shoot the ends to fit them to the case dados.

Cut the dados in the dividers in the same way the case dados were done (with saw and chisel) then fit the dividers and glue them in place. Any small errors in fit will be covered by bead moulding on the divider fronts.

For the back, cut shiplap joints on a few 1/4"-thick pieces of secondary wood and nail them to the case rabbets.

The final task on the case is to make the cornice cove moulding and the bead moulding that covers the drawer dividers. Make each of the mouldings from one length of wood (some slight variation along the length is typical). To get a consistent profile at the miters, they should be cut with as little waste between the pieces as possible.

Define the 1" width of the cornice moulding with a marking gauge before sticking the moulding. Define the top bead with a marking gauge and a moving fillister, then define the 1/8"-wide fillet at the bottom edge of the

moulding. Now use the sole of a No. 14 round plane as a circle template to connect the scribed lines with an arc. All layout work must be done on both ends and down the length of the wood to ensure a consistent profile.

I use a gouge to quickly remove most of the waste, then smooth down to the line with the same No. 14 round used to define the arc. Burnish the profile with a handful of shavings and rip the moulding off the motherboard, cutting on the marking-gauge line.

Smooth the back of the moulding if necessary, then miter, glue and nail the moulding to complete the case top (unfilled, visible nail heads are common in William & Mary-style furniture).

There are two different styles of bead mouldings for the case. The outside stile mouldings start out at 1/2"-thick x 1/2"-wide and feature a single bead, while the interior divider mouldings start out at 1/2"-thick x 3/8"-wide and feature a double bead.

To make the single bead, set a mov-



Waste not. Use primary wood only on the part of a piece that shows – in this case, the bottom panel of the top section. I glued up a walnut and pine panel to save my “good” wood for where it’s needed.



Size to fit. I use the same 3/8" chisel I'll use to cut the dados to define the dado shoulders. That way, I know I have the perfect-sized tool for the job.



Saw guide. A straight piece of stock clamped at the dado shoulder helps to guide my saw for a straight cut.



Rabbets. A moving fillister plane makes quick work of rabbets of many sizes, both with and across the grain, thanks to its retractable “nicker” and movable fence.

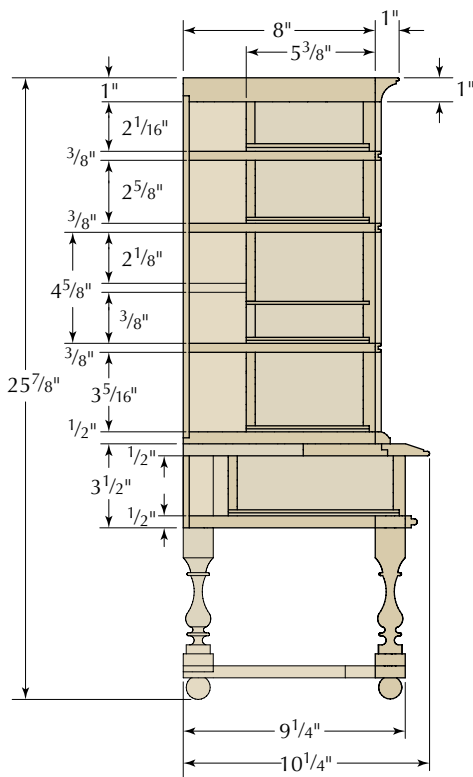

SECTION

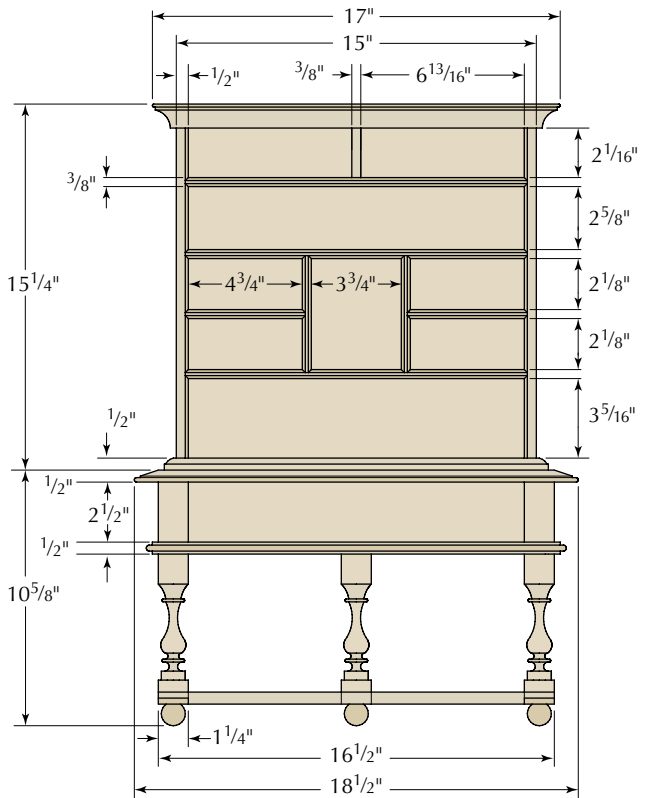

FRONT VIEW

ing fillister to cut a $\frac{3}{8}$ "-wide x $\frac{1}{4}$ "-deep rabbet along the length. Then round the fillet over with a No. 2 hollow plane. The double bead starts with a $\frac{1}{8}$ "-wide x $\frac{1}{4}$ "-deep groove down the middle of the $\frac{3}{8}$ "-wide stock. Then round over the $\frac{1}{8}$ " fillets with the same No. 2 hollow plane. Cut the mouldings to fit, mitering the corners at all intersections.

Make a Stand

The stand is made up of the entablature (the top of the base is thus named due to its similarity with the top of the classic Greek temple form), the legs, the stretchers and the feet.

The legs are made of two separate parts. The square top blocks are mortised for the side rails and the two rear blocks are also rabbeted to receive the entablature back (the back rail). The back is simply nailed into these rabbets using cut nails. The two front blocks have a single dovetail cut into the bottom that engages the lower drawer rail and ties the structure together. Finally, the bottom of each square has a $\frac{1}{2}$ "-diameter, $\frac{3}{4}$ "-deep hole, into which the tenon on the turned portion of the leg fits (to be drilled later).

Each turned leg has a round tenon at the top and a $\frac{1}{2}$ "-diameter x $\frac{1}{4}$ "-deep

hole bored into the center of the bottom. This receives the $\frac{1}{2}$ "-diameter x $1\frac{1}{4}$ "-long tenon that is turned into the top of the ball foot; it passes through the stretchers before entering the leg to lock the stretchers and legs together.

The top of the entablature is not solid; it is simply a moulding that is nailed into the tops of the stand sides and front corner blocks. These pieces serve three purposes: They make a strong waist moulding (an important design detail for William & Mary furniture), they connect the case to the stand and they provide a place in which to nail the small ogee transition moulding (cut with a dedicated ogee moulding plane) that hides the through-dovetails joining the case sides to the case bottom.

Follow the same layout and rabbeting practices used while making the cornice. In the same manner as the bead on the cornice, the bead on the end of the wide waist moulding is cut with a moving fillister then rounded over with a No. 4 hollow plane. The middle bevel of the waist moulding is simply planed down with a bench plane. You can also now stick the ogee transition moulding on one long piece of stock. And even with



Cornice moulding. A gouge makes quick work of the bulk waste removal before smoothing to the shape with a No. 14 round plane.



Double bead. This moulding starts out with a groove down the center, cut with a moving fillister plane. Then round over the sharp arrises with a No. 2 hollow plane.

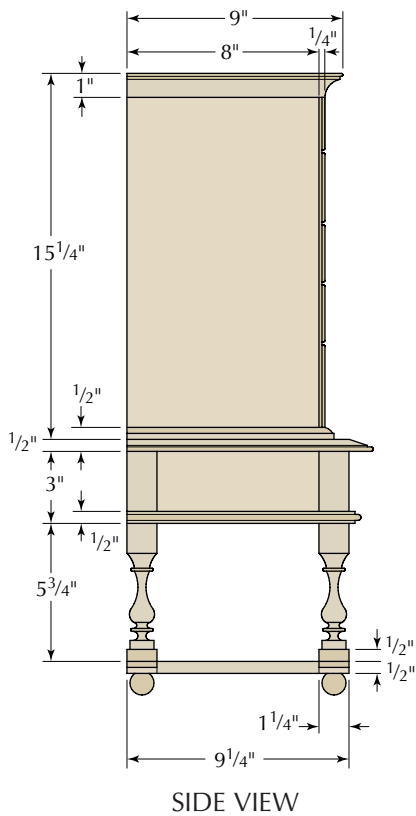

a dedicated plane – by far the best way to make this moulding by hand – your work will look better if you crosscut, miter and join this moulding with as little waste between the cuts as possible.

A 1/4" x 1/4" rabbet on the back edge of the waist moulding forms one half of a shiplap joint that connects the case and stand. It is cut with a moving fillister plane. The other half of each shiplap is cut into two short pieces that are nailed into the bottom of the case.

After you've assembled the entablature, flip the case onto its top. Carefully line up the stand so that it is centered on the case, then slide the rabbeted scrap into place to form the shiplap joint with the rabbeted moulding. Nail the rabbeted scraps into the bottom of the case to join the top to the bottom. Do not use glue; the case must be free to move with the seasons. (It's also handy to be able to easily separate the case and stand in the event a repair is needed down the road.)

Now nail and glue the transition moulding, but only to the entablature, not to the case.

With that done, separate the case from the stand until final assembly.



Case & stand connection. Two scraps with a rabbet on one edge are nailed to the bottom of the case on either side; they form a shiplap joint with a rabbet in the moulding on the stand. This setup holds the case and stand together.

William & Mary Spice Chest

NO.	ITEM	DIMENSIONS (INCHES)			MATERIAL	COMMENTS
		T	W	L		
CASE						
□ 1	Top	1	8	14 1/2	Walnut	
□ 2	Sides	1/2	8	15	Walnut	
□ 1	Bottom	1/2	8	15	Walnut/pine	
□ 3	Long hor. dividers	3/8	7 3/4	14 1/2	Walnut/pine	
□ 2	Short hor. dividers	3/8	5 1/4	5 3/16	Walnut/pine	
□ 1	Top vert. divider	3/8	2 9/16	2 1/4	Walnut/pine	
□ 2	Middle vert. dividers	3/8	5	4 7/8	Walnut/pine	
□ 1	Cornice moulding	1	1	40	Walnut	Trim to fit
□ 1	Stile moulding	1/2	1/2	30	Walnut	Trim to fit
□ 1	Divider moulding	1/2	3/8	65	Walnut	Trim to fit
□ 1	Back	1/4	varies	14 1/2	Pine	Shiplapped
□ 2	Base connectors	1/2	1 3/4	5	Pine	Rabbet outside edge
DRAWER FRONTS*						
□ 2	Top	1/2	2 1/16	6 13/16	Walnut	
□ 1	Upper	1/2	2 5/8	14	Walnut	
□ 4	Middle	1/2	2 1/8	4 3/4	Walnut	
□ 1	Center	1/2	3 3/4	4 5/8	Walnut	
□ 1	Bottom	1/2	3 5/16	14	Walnut	
□ 1	Base	1/2	2 1/2	14	Walnut	
STAND						
□ 2	Side rails	1/2	3	7 1/4	Walnut	
□ 1	Back rail	3/8	3	14 1/2	Walnut	
□ 1	Drawer rail	1/2	1 1/4	14 1/2	Walnut	Dovetail both ends
□ 4	Upper blocks	1 1/4	1 1/4	3	Walnut	
□ 5	Legs	1 1/4	1 1/4	6**	Walnut	3/4"-long 1/2"-dia. tenon
□ 5	Lower blocks	1/2	1 1/4	1 1/4	Walnut	
□ 1	Front stretcher	1/2	2 1/2	16 1/2	Walnut	
□ 2	Side stretchers	1/2	2 1/2	9 1/4	Walnut	
□ 1	Back stretcher	1/2	1 1/4	16 1/2	Walnut	
□ 5	Feet	1	1	2 1/8	Walnut	
□ 1	Wide waist moulding	1/2	2	40	Walnut	Rabbet inside edge
□ 1	Narrow waist mldg	1/2	1/2	40	Walnut	
□ 1	Base moulding	1/2	1/2	40	Walnut	

*Drawer sides, back & bottoms are 3/8" thick, with applied slips to bottoms; **1/4" Stub tenon on center leg

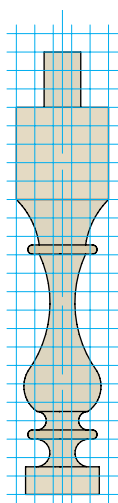

LEG
PATTERN

Grid =
1/4" Squares



Curve cuts. To cut the curved stretchers, I make a series of relief cuts, then carve to my layout line with chisels and gouges before fairing the curves with rasps, files and scrapers.

Five legs. Whatever pattern you choose, you'll need five good legs. It's always a good idea to turn an extra or two, so you can choose the ones that best match.

Once you've finished the entablature, you can focus on turning the legs. Any period pattern will be appropriate here. Lacking a good-quality photo of the turning profile of the original, I made my best guess and proceeded.

My profile is predominantly a vase-form turning, with some cove transitions and a pair of beads. You may choose to use my pattern (see above), or you can design your own from period furniture books.

The important thing to remember is to keep the transition between the square portion at the top and the round portion at the bottom as clean as possible. You want a sharp delineation of those corners. Also remember to include some extra length to turn the 1/2" tenon that holds the two parts of the leg together at assembly.

Stretchers Support the Legs

The stretcher setup is important for the overall strength of the piece. Unlike later styles, in William & Mary pieces the legs are simply tenoned into the entablature – only the stretchers and the shear-strength of the tenon prevent the legs from moving side to side. The stretchers are 1/2" thick with an additional 1/2"-thick block at each of the five leg locations, as shown in the illustrations on page 42.

The first step is to use the entabla-

ture to lay out the length of the stretchers. These must match precisely.

Once you have the final length of each stretcher established, you can lay out the curves on the front and side stretchers. The way I do this is to take a piece of construction paper, draw the end and middle squares of the front stretcher, then use a compass to connect them with an arc. Working on the radius closest to the front of the stretcher, I simply adjust the curve until the arc pleases my eye. Next, while holding the pivot point of the compass at the same point, adjust the compass to reach a

rear corner of one of the blocks. Draw the final arc. (This keeps the design parallel over its entire length.) Once you have the curves laid out, cut out the shape with scissors and use the pattern as a template for your curve, mirroring the template to draw both sides of the front stretcher. Follow the same procedure to lay out the curves for the side stretchers.

Cut the curves in the stretchers with a bowsaw, or make a series of relief cuts with a backsaw then carve to the line with chisels and gouges. Either method is perfectly acceptable; both are cleaned up with rasps, files and scrapers. It's really a matter of preference and available tools.

Cut the half-lap joints that connect the four stretchers to one another. Clamp the dry-assembled stretchers to the bottom of the entablature and

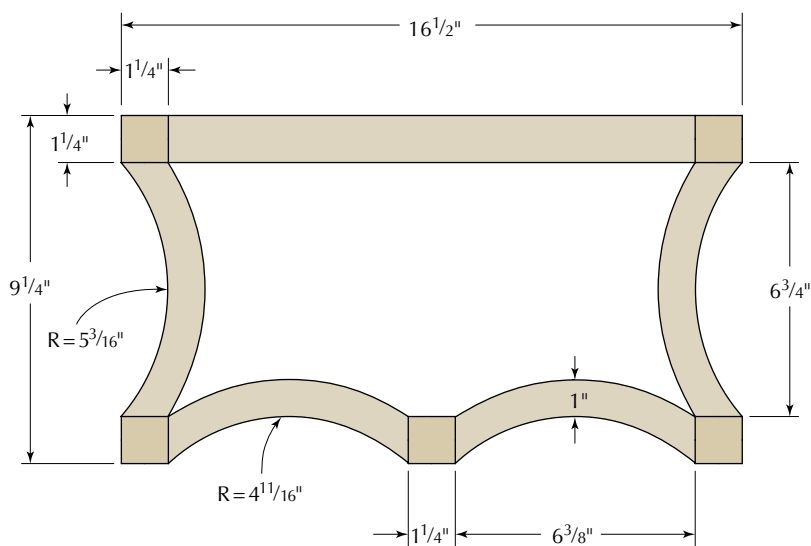

BASE PLAN

bore 1/2"-diameter holes through the stretchers and into the entablature. This ensures that the holes will align at assembly.

Once you've completed the stretchers, assemble the stand by gluing the turned legs into the entablature. Then assemble the stretcher half-laps over the tenon in the ball foot, smear some glue on the foot tenon and insert it in the hole in the bottom of the leg.

The last step before moving on to the drawers is to apply the 1/2" x 1/2" astragal moulding between the rails and the legs. This moulding is cut by planing a 1/8"-deep x 1/4"-wide rabbet on both the top and bottom edges then rounding the resulting fillet with a No. 4 hollow plane.

Drawer Construction

The number of drawers in this project may seem daunting to a novice dovetailer, but there is no reason why a committed beginner should feel this way. Gang-cutting the tails (cutting both sides together) helps make your tails consistent on each drawer and it's faster (two good reasons for a tails-first approach). Try it; I guarantee you will be a better dovetailer when you've finished.

To begin, prepare your drawer stock to the proper widths as described in the cutlist, leaving a little extra width for final fitting. Then cut a 1/4"-deep x 3/8"-wide rabbet for the drawer bottom in the drawer fronts, sides and bottoms before crosscutting the pieces to final length (it's less work and easier to cut the rabbets in longer workpieces). Then shoot the crosscuts to make sure they are as accurate as possible.

Each drawer has half-blind dovetails at the front and through-dovetails at the back. I lay out by eye because I prefer a little variance in the tails. The exact number of tails is based on the width of the sides. For the shallower drawers I have two full tails and a half tail on the bottom to hide the rabbet for the drawer bottom. Slightly later pieces might feature London-pattern tails, but on an early piece such as this layout is often less cosmopolitan.

Now cut your dovetails and assemble the drawers. After assembly, cut the

remaining sliver of wood away from the rabbet in the drawer back. You could use a narrower piece, but I find this process provides effortless consistency – not something easily achieved when working only with hand tools.

The drawer fronts shouldn't easily fit into the openings at first; I want them to be too tight. This gives you plenty of material to plane off for a good fit. You can replicate the "slack drawers" common in period work, as I did, or make them fit perfectly. It's up to you.

The large central drawer gets special attention for two reasons. It is the only drawer with a keyed lock, so I have to pay more attention to the drawer front's initial fit – because on a small piece such as this, I typically fit the drawer front's height to the opening then sink the lock mortise in just below the surface of the top edge before dovetailing. I find this makes the lock installation easier because I have large hands (on a larger piece, I'd install any locks after construction was complete, as is the more typical approach).

The second reason the central drawer is special is that it holds a secret – a false bottom that runs in grooves rabbeted the drawer parts as on all the other drawers, and there is a true bottom and drawer slips on which the drawer rides. There is simply an approximately 1 1/2" gap between the two bottoms. The secret area is open in the back (accessed by fully removing the drawer); you can keep small items in there.

You may wish to let the drawer hardware speak for itself and just use a plain drawer front. But you can dress up the front of the chest by using figured veneer on the fronts if you choose. Because William & Mary pieces commonly feature walnut burl veneer on high chests, I decided to use it on mine (see "Hammer Veneering" on page 46 for more information).

In addition to the 10 visible drawers, this piece has four secret drawers and the one aforementioned secret compartment (the false bottom in the center drawer). These are made to fit in the space remaining behind the drawers.

There are three secret drawers be-



Half-blinds by eye. You can step off your dovetail layout with dividers, but doing it by eye adds a pleasing variation and guarantees a hand-cut look.

hind the large central drawer and the two banks of drawers flanking it (all are the full height of the cavity). The central hidden drawer directly behind the locked drawer features a ribbon pull to help remove it. To access the hidden drawers to either side of the center one, first remove the locked drawer and the hidden drawer behind it. To remove a drawer from the side bank, reach in and push the hidden drawer behind it toward the center (it can be removed only through the large center opening).

There is also a 6"-long hidden drawer behind the two upper drawers. To access it, remove the two upper drawers, then reach in to rotate the hidden drawer to pull it out through one of the openings.

Following period practice, the secret drawers are all simply rabbeted and nailed together.

SUPPLIES

Londonderry Brasses
londonderry-brasses.com or
610-593-6239

10 ■ drop pulls
#WM-84

Horton Brasses
horton-brasses.com or
800-754-9127

1 ■ escutcheon
#H-115E

1 ■ lock
#LK-1

1 ■ strike plate
#SP-1

Call for pricing



Grimy & perfect. Pigmented shellac gets into the open pores of the walnut to simulate years of exposure to smoke and dirt.

Finishing the Piece

I prefer my pieces to look like antiques now, not what they looked like when they were new (a longer process than applying a new-looking shiny finish).

My recipe for the case and the top part of the stand is two coats of 1-pound-cut blonde shellac as a “base” on the carcass, then a dark-red walnut aniline dye, which I let sit for about 30 seconds before wiping it off. This provides a nice red coloration, similar to the oxidation that walnut experiences over time. The shellac is to prevent the dye from penetrating too deeply into the wood so that it can be more easily removed if a mistake is made.

After the dye, I use brown and black iron oxide pigment to make a dark-tinted seedlac. Brush on two coats and let the piece dry for an hour. Then soak a rag in pure-grain alcohol and wipe off most of the pigmented shellac. Because walnut is porous, a fair amount of it remains in the pores, providing a grimy look. Plus, it’s difficult to wipe out of mouldings and corners – which is exactly where soot, grime and dirt would accumulate over three centuries.

Over this, I apply two more coats of blonde shellac that are rubbed out with rottenstone and linseed oil, then I leave the oil to dry on the surface. Buffing provides the luster I’m after.

On the veneered drawer fronts, the only finish is seven coats of blonde shellac, using a roughly 1-pound cut. Each coat is rubbed out with #0000 steel wool before brushing on the next coat. After the final coat is dry, buff it with

HAMMER VENEERING

Veneering is a great way to add surface decoration to almost any piece of furniture. While modern adhesives call for elaborate clamping cauls or vacuum-clamp setups, the traditional approach to veneering requires only a hammer. Not a “normal” hammer but a veneer hammer. This tool is basically a squeegee made from hard material, usually a non-ferrous metal or boxwood. Mine is shop-made with a cherry head, a red oak handle and a boxwood bit.

The traditional technique is to coat the substrate with hot hide glue, then lay the veneer down and coat the show side of the veneer with glue as well. Using the veneer hammer like a squeegee, you squeeze the glue out from between the veneer and the substrate. The glue on the show face lubricates the hammer and prevents you from damaging the veneer. It also equalizes the moisture on both faces of the veneer, preventing it from curling up. Cover the veneered piece with a damp rag (to prevent the veneer from drying too quickly, because that too can cause it to curl) and set it aside to dry.

I often choose liquid hide glue rather than hot hide glue for hammer veneering. Many people say it can’t be done; the veneered drawer fronts of this chest are the proof that it can be. The technique is much the same as when using hot hide glue. I keep the glue bottle in a glass of hot water to decrease the viscosity a bit and therefore use significantly less glue to lubricate the hammer. I still squeeze the glue out with the hammer, and I cover it with a damp rag as the glue sets.

I like liquid hide glue simply for the ease of preparation. I don’t have to cook it ahead of time, nor do I have to worry about it spoiling. I on occasion use hot hide for complex veneer work. But for simple, quick work such as these drawer fronts I recommend liquid hide glue.

—ZD



Shop-made hammer. Commercial veneer hammers are available, but you can make your own squeegee out of wood.

rottenstone and linseed oil.

For the legs and stretchers, I use an oil-based stain tinted with brown and black iron oxide and linseed oil. It’s painted on in several coats, with special attention to thickly coat the creases of the turnings. I then rub this out a little to impart some sheen and to wear through in places. I couldn’t be happier with the color variation in these areas, because this is exactly what 280-year-old furniture looks like: gunky, a little streaky and slightly worn down. **PWM**

*Zachary builds custom pieces by in Charlotte, Mich.
His web site is theeatoncountyjoinery.com.*

ONLINE EXTRAS

For links to all online extras, go to:

■ popularwoodworking.com/aug13

BLOG: Read Zachary Dillinger’s hand-tool blog.

ARTICLE: Read Charles Bender’s article on the William & Mary style from our April 2010 issue (#182).

BLOG: Read more about how the author builds drawers for his 18th-century reproductions.

IN OUR STORE: “Building 18th-Century American Furniture,” by Glen D. Huey.

Our products are available online at:

■ ShopWoodworking.com

Double-bevel Artistry

BY JAMEEL ABRAHAM

A scrollsaw and simple steps yield stunning inlay results.

Picture a two-layer cake. Using a knife, cut a circle out of the middle while holding the knife perfectly vertical. You now have two cylinders of cake that you can easily pull out of the rest of the cake.

Now start again with a fresh two-layer cake, but this time tilt the knife handle in toward the center of the cake as you cut the circle. You now have two cones, each smaller toward the top of the cake, tapering to larger at the bottom. The top cone pulls out easily. (Feel free to eat that piece.) The lower and larger cone from the bottom half of the cake, however, you can pull up

only so far before it wedges itself in the top layer's conical hole. It fits so well, in fact, that it virtually disappears. That's because it exactly matches the shape of the hole, because both were cut at the same time.

That's how double-bevel marquetry works.

So how does double-bevel inlay work? Exactly the same way – but instead of using thin veneers, we're using thicker wood, $\frac{1}{8}$ " thick and up. This allows us to do inlay precisely and accurately in thicker woods that can in some cases be used themselves as structural members of a project, not just



as veneer. The inlay can be as simple as an oval, or as complex as an elaborate fleur-de-lis. But oval is boring, so let's get fancy and French.

Tools & Materials

This technique can be done by hand with a fret saw and angled platform, but it's extremely difficult to maintain the correct angle. I recommend a modern scrollsaw; not only is it convenient, it's the best tool for the job.

Get your saw tuned up and running smoothly, and wax the tables for free movement of your stock. You may also want a magnifying lamp or visor to aid in following your line. For anything up to 1/4" thick (total) I use 2/0 jeweler's saw blades. They cut slowly, but you can get incredibly crisp details with them.

First you need to gather your two materials. For this design I'm using pre-ban, reclaimed ivory (certified and legal of course) and rosewood. You can use any materials you like, but harder materials cut better, and denser materials hold detail better. If you want to start with more humble materials, any good-quality hardwood will work – and wood in wood looks great, too. (Holly is a nice light, uniform wood that works well.)

Prepare both the inlay wood and the background wood to the exact same

"Every artist was once an amateur."

—Ralph Waldo Emerson (1803-1882),
American author and lecturer

thickness and size (plus a little extra length for test cuts.) For my fleur-de-lis, the thickness is about 1/8" for each layer. That also means my finished inlay is going to be 1/8". You'll need to join the two pieces together for the cutting, but only around the perimeter. You want the pieces to fall free as you cut each one out. On smaller pieces I use a dot of cyanoacrylate (CA) glue on each corner. For larger pieces I'll brad nail each corner, then clip the excess off and peen it down into the wood. This keeps the layers tightly together, and free to slide around the saw table.

Place the material you want for the inlay on top and the background material on the bottom. If the background needs to be much larger than the inlay (if, for example, you're inlaying a large rosette with lots of background space around the inlay itself) you can use a smaller piece for the inlay area. Use glue dots to adhere it in this case, because you don't want the extra nail holes.

Design

Print out or draw your design on a piece of white paper. I typically sketch designs by hand, then refine them using drawing software. I print them out in the finest line weight, and in a gray tone. It may not seem as if it makes much difference, but if the line is something other than black, I can more easily see exactly where my saw is cutting.

After you have the drawing, glue it to the top of the inlay blank.

Now you're ready to start cutting.

Almost. You need to set the tilt on your scrollsaw table to match the thickness of the wood and the width of your blade's kerf – and you have to do it by trial and error. Here's how.

Set the Table

Set your scrollsaw table to a tilt of about 5°. Make a test cut. Make sure you feed in the correct direction so the background "cone" is larger at the bottom. Your saw table may tilt in either direction, and you may prefer one direction over the other depending on your dominant hand. (I usually tilt mine to the right; I'm right handed.) If you rotate your piece clockwise, the cone will be wider at the top, and the opposite if you feed counterclockwise (cone is wider at the bottom). This is important.

Because you may have your top tilted either direction, I'm not going to confuse you by telling you which way to feed. Simply cut a couple test pieces and it will become quite apparent. Sometimes you'll simply be cutting out a plain inlay without interior cuts – say, an oval of light wood set into a dark background. At other times you'll also be cutting out a design within that "oval." So first you'll cut out and "pull up" background pieces into your oval, then cut out in the opposite direction and "push down" the finished oval (with interior cuts) into the background. Again, you'll be cutting from both directions, because the background sections within the inlay will be narrower at the top (rising up into the conical cutout), with the inlay itself being narrower at the bottom (descending into the conical cutout).

If your test piece (the background) rises up into the inlay material and stops completely flush with it, you've nailed the angle. If the background

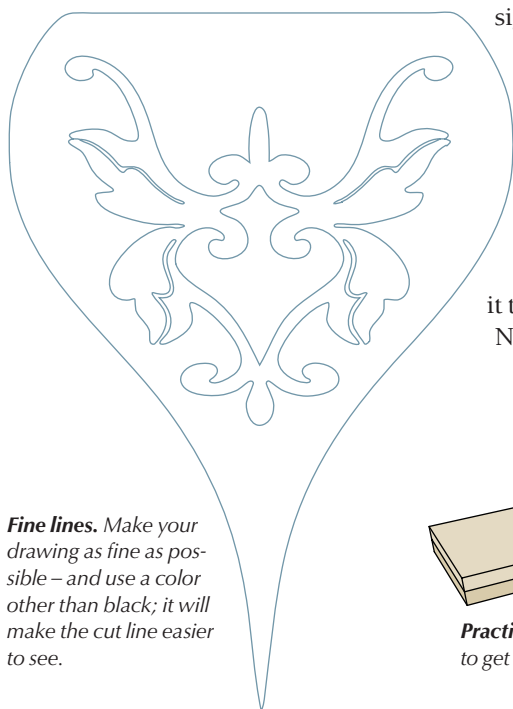

Fine lines. Make your drawing as fine as possible – and use a color other than black; it will make the cut line easier to see.

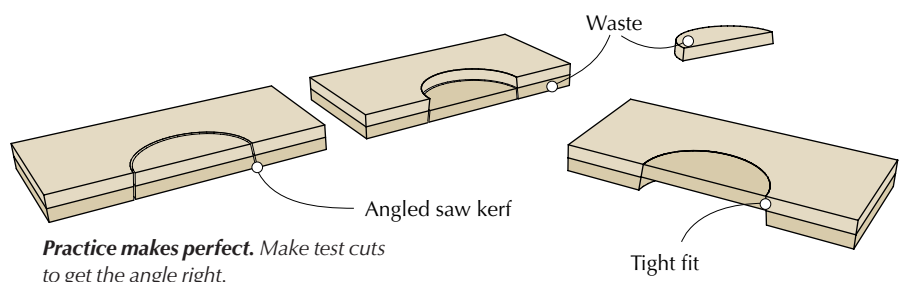

Practice makes perfect. Make test cuts to get the angle right.



Inside passage. Here's the background (the wood) and waste from an interior cut



Mind the gap. Cut the background piece then press it down into the inlay piece.

piece goes past the inlay material and ends up proud or even passes completely through, the angle is not great enough – increase the table tilt by a degree or so and do another test cut. If the piece stops before the top of the inlay material and ends up recessed, the angle is too great – reduce it and make another test cut. Once you find the angle that works with a certain blade and material thickness, write it down so you can get close the next time without a lot of trial and error.

Make the Cut

To begin cutting you'll need some starter holes. I keep them to a minimum: one in each interior cut, and one for the inlay itself. I use the smallest drill bit that allows the blade to pass through and drill them in inconspicuous places, such as acute corners. Use a drill press if you have it, or a small cordless drill. Don't use an eggbeater hand drill; you'll break the tiny bit.

In my fleur there is only one interior cut. In the picture above, I have the workpiece flipped over so the background is up. The white piece is the inlay material, so the white fleur is the waste piece. The rosewood piece is the background. You can clearly see the tapered cone shape with the two pieces removed from the cutout area.

Take the background piece and press it into the inlay material from the backside. This is the interior cut "rising up" into the inlay (in the picture above the workpiece is upside down). If you like, you can add a couple dots of CA glue as

you press it in. You don't need much. I often glue the background pieces in place as I cut them out, especially on small, complex and thinly detailed pieces. This keeps the entire structure strong as you cut out more background pieces, and then as you cut out the inlay itself. You've probably surmised that thinner sections get quite fragile by the time they taper down at the back of the inlay.

In the picture below, I've glued in the background piece. It fits perfectly. Can you see the entry holes? (There is one at the very top of the interior background piece, and the one for the inlay is just to the right of it.)

Once the interior pieces are cut (again, mine only has one) you can proceed and cut out the inlay.

Remember: You're cutting in the opposite direction now because the inlay descends into the background.

If you were cutting counterclockwise, now cut clockwise, and vice versa.

As you cut, be attentive to the corners. With typical scrollsawing you can change direction by nibbling into adjacent waste material – not so much with this technique. There is very little waste material because you are keeping adjacent material (for the next layer, of course.) While you can get away with a little nibbling, it's best to simply keep moving and, if you do need to change direction abruptly, simply pivot in place and go forward.



Tight fit. If you have the bevel on your saw table set correctly and make a good cut, the background piece will fit flawlessly.



Reverse direction. To cut out the inlay, feed the piece to the saw blade in the opposite direction.



Waste extraction. Here's the inlay piece completely cut out. The separate pieces at the top are waste.



Falling down. The inlay descends into the background.



Decorative cuts. Extra kerf cuts make great shadowlines.



Get ready. Divide the components to prepare for the final assembly of the inlay.



Interior fit. Place the interior piece(s) in the inlay



Background fit. Place the inlay piece in the background material.



Flush. Now press the inlay firmly in place until it is flush.

The jeweler's blades are so small you can get by with more than you think. Take it slow. And run the saw slowly as well – almost as slowly as it will go, in fact, especially with harder materials.

With the inlay piece completely cut out, assemble the components. Place the inlay piece into the background and let it descend into place. But don't push it in tight. If it looks as if it's going in fine, immediately flip the piece over and let it fall out. The fit is so good with this technique that the fragile areas of the inlay may get wedged in if you insert it fully then remove it for the next step.

After all the double-bevel cutting is done, return the saw table to square and place a zero-clearance board on the scrollsaw for the next step, because you'll be handling the fragile piece. Cut decorative single kerf lines if your design includes them. (I like them because they add some shadow lines in the leaves of this design.)

Assemble Your Inlay

Now separate the two original layers of material by cutting away the corners where they were joined by glue or brads

then get rid of the waste. You've probably realized that because of the double bevel, they won't fit together anyway (you can't have your cake and eat it too).

Assemble the pieces together using a few dots of CA glue on the inside edge of the cutouts. Because you'll be gluing this inlay onto a substrate – inlaying the inlay – you don't need much glue to hold the pieces together in the interim. If you are making a more robust inlay that forms a structural component in a piece, you should glue the entire inlay and background piece in place. But don't use too much glue; the fit is tight, and you don't want a glue line to appear in your finished work.

With the inlay in place you can see how perfect the fit is. Also notice how the grain in the background wood flows perfectly in line with interior piece.

You can now level the finished piece on a flat sanding platen (by hand of course). It won't take much if your bevel angle was correct; the pieces should automatically be quite flush.

The decorative kerfs in this piece were filled with fine rosewood dust and CA glue.

You can now cut out the background to your desired shape and even inlay it into another piece if you wish, as I did with this one, as shown in the opening photo.

The possibilities for decorative work with this technique are endless. With a little careful material prep and scrollsaw setup, you'll be rewarded with fantastic results. **PWM**

Jameel is a woodworker and co-owner of Benchcrafted (benchcrafted.com).

ONLINE EXTRAS

For links to all online extras, go to:

■ popularwoodworking.com/aug13

PATTERN: Download the pattern used for the inlay in this article.

MODELS: See the author's progression of SketchUp scenes that lead you through the double-bevel inlay process.

BLOG: Read the Benchcrafted blog for more from Jameel Abraham.

IN OUR STORE: "Creating Veneer, Marquetry & Inlay" DVD.

Our products are available online at:

■ ShopWoodworking.com

SOUTHERN GENT'S Mirror Stand

BY GLEN D. HUEY

My first trip to the Museum of Early Southern Decorative Arts was for business. Robert W. Lang, the magazine's executive editor, and I traveled to Winston-Salem, N.C., to research and select furniture projects for the book "Furniture in the Southern Style" (Popular Woodworking Books).

Upon our arrival, we did not head straight for the museum showrooms as you might expect. Instead, we headed toward a furniture junkie's dream – a basement filled with file cabinets, each stuffed with furniture photos and related information.

Among the candidates for the book's projects was a small mirror stand. My fondness for this form usually falls to Federal-period designs, yet there was something about this unadorned Southern shaving mirror that caught my eye. It is different; it's captivating.

Make Mine with a Twist

A few days in the shop should be enough time to build this project. It is, from a construction point of view, simple to build. Joinery is no more complex than the typical mortise and tenon and a few rabbet joints, plus slip joints for the mirror's frame. The mirror face and crest are applied to the frame.

To begin, mill the pieces for the base top, bottom and sides. The only catch is that the sides are wider than they are long in order to keep grain direction consistent around the base.

The base sides have simple $\frac{9}{16}$ " x $\frac{3}{4}$ " rabbets at the bottom and top edges. I cut those using a two-step method at my table saw; one cut is with the piece

Discovered in a museum basement, this Piedmont design makes heads turn.



flat to the table and the other is run with the piece on edge. After the rabbets, the bottom joinery is complete. But to join the top to the base there is a twist: The rabbeted area is modified with a 45° miter on the remaining edge of the side's rabbet as shown below.

The top is longer than the bottom to allow for the matching angle detail. With your top sized, cut a $\frac{3}{16}$ " x $\frac{9}{16}$ " rabbet at both ends. Your first angle cut has an uncut, square edge riding against your fence, but as you attempt the cut on the second end, the previously mitered end can slip under your fence and give you trouble. To avoid this problem, set up your cut using a piece of scrap fit between the fence and the square shoulder of your workpiece. Trim the $\frac{3}{16}$ "-square protrusions to a matching 45°.

All four base pieces are rabbeted for a back. I used a $\frac{1}{4}$ "-thick back and cut my rabbets $\frac{5}{16}$ " deep.

The base can be only partially assembled at this time. The bottom is fit into the side rabbets and screws are driven through pilot holes. Insert two screws per side, spaced about 1" in from the outside edge. It also helps if you



Twisted rabbet. The small bevel cut on the edge of the top rabbet eliminates end grain from the show surface.



Base two. To make the second base side and get a matching part, it's best to work from your completed base than from the pattern.

angle the screws slightly to catch more of the meat of your side. The top is later attached by screws driven through the mirror post bases.

The post bases are 1" thick. Use a paper pattern to lay out a base. Cut the shape from your stock then sand and clean any rough surfaces. Use that workpiece to lay out the second post base.

Each base is mortised for the $\frac{1}{2}$ "-square post tenons. There are a couple of ways to chop the $1\frac{1}{4}$ "-deep mortises, depending on your method of work. I used a dedicated mortise machine, but you could just as easily drill a $\frac{1}{2}$ "-diameter hole then square the corners.

Establish Your Goal

When assembled, the mirror stand reminds me of goal posts at a football game. While these pieces are too small for a field goal attempt, they do need to stand straight, strong and square.

"The real man smiles in trouble, gathers strength from distress, and grows brave by reflection."
—Thomas Paine (1737-1809), political activist & author



Simple fix. Because the mitered end can slip under the fence, a spacer set between the rabbet and fence allows one setup for both end cuts.



Squared hole. Cut a $\frac{1}{2}$ " x $\frac{1}{2}$ " mortise that is $1\frac{1}{4}$ " deep and centered on each post base at the crown of the piece.



Accelerated & accurate. "Bump-cutting" the tenons at the table saw is a quick technique if you only have a few tenons to make.

Mill the material for the mirror posts and crossbar. The posts for this project have an egg-shaped detail at the top that is turned at a lathe. If you don't have a lathe, you can create this detail by hand using rasps and chisels, or you can change the design to a more simplified detail, such as a pyramid shape that is easily cut or planed.

After the post detail is made, the next step is to locate and cut mortises for the crossbar. The mortises begin $\frac{7}{8}$ " above the tenons, or $2\frac{1}{8}$ " off the post's end, and are $\frac{3}{4}$ " in length and $\frac{1}{2}$ " wide.

To form the tenon at the base of each post, set the saw's depth of cut at $\frac{1}{4}$ " with the fence set for a $1\frac{1}{4}$ "-long tenon. Use the miter gauge as a guide as you slide the workpiece back and forth, bumping the fence as you simultaneously push the workpiece over the blade. I call this cut a "bump cut." Repeat this process on all four faces and you have the tenon cut. If necessary for an exacting fit, pare the tenons.

While you have the saw set up for these tenons, create the $\frac{1}{2}$ "-long tenons on the ends of your crossbar. These are also bump-cut at the table saw.

When you finish the mortise-and-tenon work on the posts and crossbar, measure and mark the start and stop locations for a routed chamfer on each. The post chamfers begin $2\frac{5}{8}$ " up from the tenon and are 10" long. The cham-

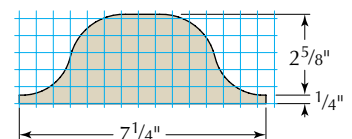

SIDE PATTERN

Grid = $\frac{1}{2}$ " squares



Not so square. To gain a bit more strength, tenons on the crossbar have smaller edge shoulders and larger cheeks.

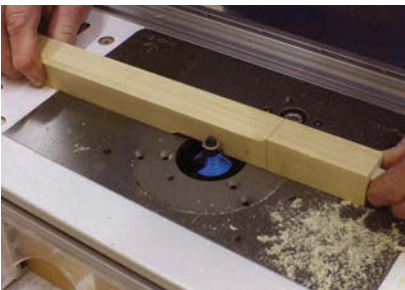

Break the edge. A chamfer bit in your router table makes quick work of the 12 chamfers on the posts and crossbar.



Check for racking. Because it's so easy to rack the small assembly, it's not good enough to clamp without checking for square.

fers on the crossbar are 7" in length and are centered from side to side. Set stops if you feel it's necessary, but I prefer to freehand these cuts.

Before you can assemble the posts and crossbar, drill 1/4"-diameter holes through the posts for the dowels that allow the mirror to swivel. To assemble the mirror stand, spread glue in the mortises and on the tenons then slip the parts together. Clamp the assembly at the crossbar and make sure the posts are square to the crossbar. (Securing the clamp can rack the glue-up.) When

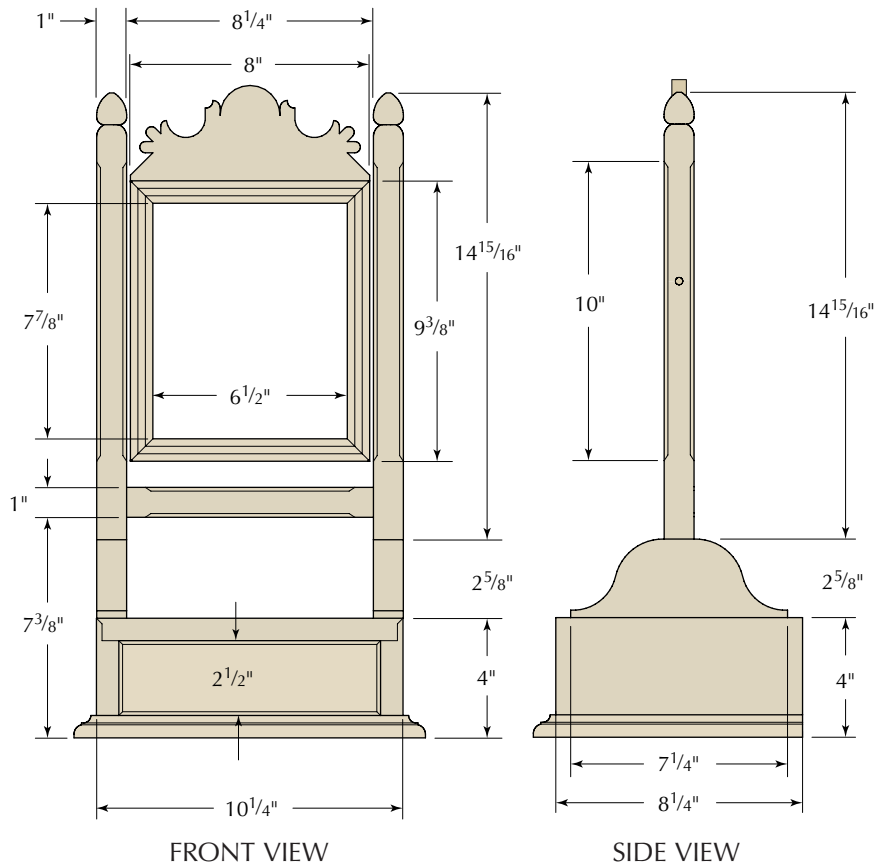

Southern Gent's Mirror Stand

NO.	ITEM	DIMENSIONS (INCHES)			MATERIAL	COMMENTS
		T	W	L		
□ 2	Base sides	3/4	8 1/4	4	Poplar	Grain runs from top to bottom
□ 1	Base bottom	3/4	8 1/4	9 7/8	Poplar	
□ 1	Base top	3/4	8 1/4	10 1/4	Poplar	Rabbet with a 45° bevel cut
□ 1	Base moulding	11/16	5/8	36	Poplar	Material to wrap three sides
□ 1	Base back	1/4	3	9 7/8	Poplar	
□ 2	Post bases	1	2 5/8	7 1/4	Poplar	
□ 2	Mirror posts	1	1	16 3/16	Poplar	1 1/4" TOE*
□ 1	Crossbar	1	1	9 1/4	Poplar	1/2" TBE**

MIRROR

□ 2	Mirror backs – long	1/2	1/2	9 3/8	Poplar	
□ 2	Mirror backs – short	1/2	1/2	8	Poplar	1/2" TBE
□ 2	Mirror faces – long	1/4	3/4	9 3/8	Poplar	
□ 2	Mirror faces – short	1/4	3/4	8	Poplar	
□ 1	Mirror crest	1/4	3 3/8	8	Poplar	

DRAWER

□ 1	Front	3/4	2 1/2	8 3/4	Poplar	
□ 2	Sides	1/4	2 1/4	7 3/4	Poplar	
□ 1	Back	1/4	2 1/4	8 1/2	Poplar	
□ 1	Bottom	1/4	7 3/4	8 3/4	Poplar	

*TOE = Tenon one end; **TBE = Tenon both ends



Easy to cut & strong. Sometimes called an open mortise-and-tenon joint, a slip joint is strong when used on small parts such as these.



Motherboard? The mirror frame's front pieces are profiled on a wide board then sliced free to avoid working with small and thin pieces.

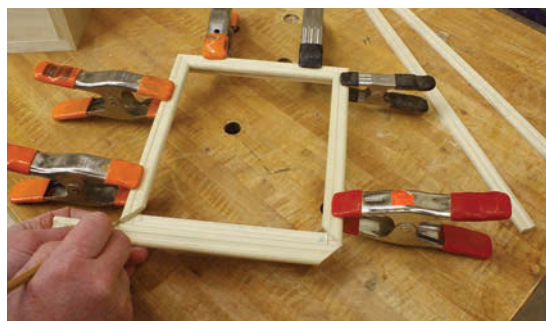

Reverse & mark. The last piece of the frame can be difficult to size. Reverse the piece, match the miters at one end then mark the opposite end with your exact cut location.

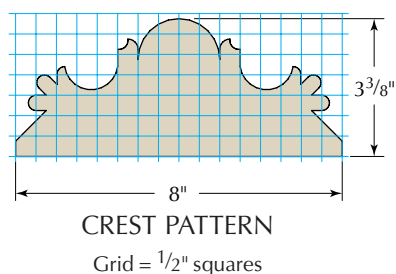

everything is square, set the unit aside to allow the glue to dry.

Non-traditional Mirror Frame

The steps I used to build the mirror frame vary from traditional methods. I built the frame back, applied the mirror's front pieces then cut a small groove for the mirror crest. The results are a solid mirror that will withstand years of use.

To begin, mill and cut the mirror frame pieces to size. The corners are joined with a slip joint. Cut tenons on the ends of the short (top and bottom) piece, then cut a slot in the long (side) pieces as shown above. Apply glue to both parts of the joint, slip the mirror frame together and check that it's square, then set it aside as the glue dries.

Use a 1/8"-roundover bit to profile the edges of the frame faces. Create a small trough at the center of the faces using a 1/2" core box bit at your router table.

SUPPLIES

Horton Brasses Inc.
horton-brasses.com or 800-754-9127

1 ■ desk interior knob
H-42, 3/8"

Call for prices.



Fine-tuned by saw. Areas of the crest, such as on either side of the half-round at the top, are difficult to get into when cutting at a band saw – but a thin Japanese dozuki is perfect to clean up these cuts.



Buck tradition. Mirror crests were usually attached to frames using small glue blocks, but a small groove holds better.

Set the depth of cut shallow (1/8" deep).

The faces are mitered and fit to the frame. Apply glue then use spring clamps or 23-gauge pins to hold things in place until the glue dries.

The mirror crest begins as a paper pattern spray-glued onto a 1/4"-thick piece of stock that's oversized in both width and length. Cut the crest at the band saw, then clean up any rough areas using a rasp and sandpaper.

Now cut a 1/4"-wide groove along the top rail of the frame. The depth of cut is 3/16", or just deep enough to capture the crest. Put glue in the groove then seat the crest into it; keep the frame vertical so that the crest remains properly in place as the glue dries.

The next step on the frame is to hang it in the stand. Begin by drilling a 1/4" hole into one side that is centered from front to back and about 6" up from the bottom. Drill as deeply as you can without going through the frame. Slip a short piece of dowel through the post to just catch the frame. Hold the frame in position and level with the posts.

Use the same drill bit to push through the second post and mark the location on the frame. Remove the frame from the post assembly then drill the second hole used to hang the mirror.

Everything Comes Together

It's time to attach the shaving stand assemblies. Slip the top into the base then align the mirror stand in position – the mirror assembly is flush with the sides of the base and centered from front to



Best technique. To get an accurate hole location, push the bit through the post and mark the frame as you hold the frame aligned to your posts.

back. Drill and countersink holes then, using four #8 x 1¹/₄" wood screws, attach the assemblies. The screws travel through the post stands and the base top then grab into the base sides.

A moulding wraps around the front and sides of the base. I used a classical Roman ogee router bit, but any profile will do. (Again, I routed a wide board then ripped the moulding free.) The corners are mitered, and the moulding is attached using glue and brads.

The drawer is simple. I cut my drawer front to size, eased the outer edges using an 1/8"-roundover bit, then cut rabbets for the drawer sides and bottom. I glued and pinned the drawer sides to the front, and pinned the drawer back in shallow dados cut in the sides. The bottom is attached using pins.

I decided from the beginning that my mirror was going to be painted with an "aged" finish – see "Aged Look in Paint" at right for details. After the paint was complete, I cut the mirror glass to fit into the frame. Small blocks can be pinned to hold the glass in place, or you could cut and fit a full-size back.

Although this is a gentleman's shaving mirror, it is a bit small by today's standard to reflect a woodworker's mug as he scrapes away a day's stubble. It is, on the other hand, perfect for viewing earrings and necklaces, or a well-tied tie. My guess is that other members of the house will instantly lay claim to this project. **PWM**

Glen hopes one day to become a gentleman. He hopes to become a scholar, too. He can be reached at glen.huey@fwmedia.com.



Final connections. Use a couple of clamps to keep the top tight and in position as you drive your screws through the post bases.

AGED LOOK IN PAINT

I painted my Southern gent's shaving mirror then added a little antiquing by rubbing and removing paint in certain areas, then applying dark paste wax.

The process is to sand the piece smooth with #180-grit sandpaper, use #120-grit sandpaper to knock off any sharp edges, then dye the shaving mirror using a water-base aniline dye (dark brown or cherry works great). After smoothing any raised grain with #320-grit sandpaper, apply two coats of clear or blonde shellac as a sealer coat – this allows you to better manipulate your paint. Then use #320-grit sandpaper to sand the shellac.

Next, the paint is applied. Work in small areas to maintain control. As the paint dries there is time to manipulate the final surface. There are a couple of methods I use. Sometimes I rub away paint using a damp cloth, which can be done almost as soon as the surface is painted. Or I allow the paint to reach a near-dry stage then I press and remove my hand from the surface to lift paint off (I wear disposable gloves for this work).

Another great technique to age paint is to blister it using a propane torch. After the bubbled paint dries, it is easily scraped or sanded away. When colored wax (or other "grime") fills in the broken bubbles, your project can quickly look as if it's aged 50 years or more.

As you contemplate aging your piece, think about natural areas of wear such as along the moulded edges, around the drawer pull, at the top and bottom of the mirror (where someone would grab it to adjust the angle) and of course, on top of the base where items would slide. As you fiddle with the paint, remember that less is more. Also, try these techniques first on a practice board or you may find yourself adding another layer of paint. — GDH



Smooth slide. The 1¹/₁₆"-tall x 5/8"-wide base moulding fits just below the top edge of the base bottom so as not to impede the drawer operation.

ONLINE EXTRAS

For links to all online extras, go to:

■ popularwoodworking.com/aug13

VIDEO: Watch the author "bump-cut" tenons at his table saw.

BLOG: Read more about the interesting twist of the top's rabbet joinery.

PLAN: Download free, full-size drawings of the post stand and mirror crest designs.

IN OUR STORE: Read articles on more Southern furniture including a cellarette, sugar chest and small slant-lid desk.

TO BUY: Measured drawings of Southern furniture in "Furniture in the Southern Style Collection" (book and CD).

Our products are available online at:

■ ShopWoodworking.com

WOODWORKER'S MARKETPLACE

www.whitechapel-ltd.com 1(800) 468-5534

WHITECHAPEL LTD

est. 1987
Fine Brass and Iron Hardware

CARD #48 or go to PWFREEINFO.COM

CRAFTSMAN PLANS

Authentic
Reproduction
PLANS
BOOKS
HARDWARE

Measured & Drawn by Robert W. Lang
author of
"Shop Drawings for Craftsman Furniture"
www.craftsmanplans.com

Raises the art of pen-turning to a new level

The Beall Wizard

THE BEALL TOOL CO.

541 Swans Road N.E. Newark Ohio Dept. PW
1-800-331-4718 www.bealltool.com

CARD #2 or go to PWFREEINFO.COM

Looking for wood?

VISIT **woodfinder**

It's fast, easy and FREE!
www.woodfinder.com
No computer? Call toll-free 1-877-933-4637

Your Perfect Workbench Deserves The Perfect VISE

- Hard maple large vise screws
- 2-1/2 in. diameter x 24 in. length
- Fast action 2TPI thread

www.lakeerietoolworks.com
814-528-4337

LAKE ERIE TOOLWORKS
Traditional Tools for Safety & Efficiency

CARD #70 or go to PWFREEINFO.COM

100+ Hardwoods

- ☑ Hand selected orders
- ☑ 100 woods in stock
- ☑ Expert knowledge
- ☑ 100% satisfaction

800-423-2450

No one has a better website for ordering wood:
www.101woods.com

VISA PayPal

CARD #53 or go to PWFREEINFO.COM

FAST DOVETAELS

Set up in under 5 minutes.
Order your Keller Dovetail System now!
(800) 995-2456

Made in the USA since 1976 • DVD/Video \$8.95 + \$2 p/h

www.fastdovetails.com

CARD #26 or go to PWFREEINFO.COM

SHOP CLASS

Woodworking Videos at Your Fingertips

ON DEMAND

Watch what you want, any time you want with a 6-month subscription. You'll get instant access to every woodworking video Popular Woodworking Magazine produces. New videos added regularly!

SUBSCRIBE NOW AT shopclass.popularwoodworking.com

Hands on Instruction for All Skill Levels

Mario Rodriguez - Alan Turner

For more info on Courses: 215.849.5174

Philadelphia Furniture Workshop
PhiladelphiaFurnitureWorkshop.com

THE FURNITURE INSTITUTE of MASSACHUSETTS

Study with Philip C. Lowe
Classes range from 1 day to 1 week and 2 and 3 year mastery programs.

See new class schedule on:
(978) 922-0615 www.furnituremakingclasses.com

CARD #16 or go to PWFREEINFO.COM

CraftsmanStudio.com

TOOLS TO BRING OUT THE BEST IN YOUR WORK

Authorized dealers for Auriou, Lie-Nielsen, Shapton, Veritas & TANOS systerainers®

FREE SHIPPING ON ONLINE ORDERS - SEE WEBSITE FOR DETAILS - 888-500-9093

CARD #5 or go to PWFREEINFO.COM

Subscribe & Save!

Get Popular Woodworking Magazine delivered right to your mailbox - or right to your inbox with a digital subscription.

Either way, you save money - and that's more you'll have to spend on wood and tools!

Visit shopwoodworking.com/subscribe to subscribe now & start saving!

POPULAR **Woodworking** MAGAZINE

WOODWORKER'S MARKETPLACE

CLASSIFIED

Books

WE HAVE A WIDE VARIETY of woodworking books - from small projects, to home improvement, to enhancing your woodworking skills, and more! To see our full line of books, please visit our web site at [ShopWoodworking.com!](http://ShopWoodworking.com)

Finishing Supplies & Equipment

BLOXYGEN SAVES LEFTOVER FINISHES - Spray, Seal and Store.
www.bloxygen.com or (888) 810-8311.

SHELLAC.NET -- WOOD FINISH SUPPLY
Large Shellac Flake Selection - Brushes - Dyes
BEHLEN Finishing Supplies - Stains - Aerosols
RENAISSANCE Wax. 877-245-5611

Hand Tools

DI LEGNO WOODSHOP SUPPLY Quality woodworking hand tools at an affordable price.
www.dlws.com or 1-412-331-1236.

WWW.JIMBODETOOLS.COM The Largest Antique Tool Website on Earth! Fine Antique Woodworking Tools of every kind.
845-505-8665.

Kits & Plans

FULL SIZE FURNITURE LAYOUTS Drawn by Philip C. Lowe. 978-922-0615. 116 Water St, Beverly, MA 01915.
www.furnituremakingclasses.com

Schools/Instruction

JOHN C. CAMPBELL FOLK SCHOOL, Brass-town, NC. Courses for all skill levels. Week and weekend classes year-round, taught by nationally known instructors. Friendly, supportive environment. Comfortable, on-campus housing. Delicious meals served three times a day.
www.folkschool.org, 800/365-5724.

PRIVATE CLASSES with woodworking author in the Great Smoky Mountains- All skill levels-
www.GregoryPaolini.com (828) 627- 3948

THE ACANTHUS WORKSHOP, LLC Traditional woodworking education with lead instructor, Charles Bender, using conventional hand tools and modern machinery. Call 610-970-5862 or visit www.acanthus.com.

FRED WILBUR TEACHES DECORATIVE and architectural woodcarving using traditional methods. Please consult www.FrederickWilbur-woodcarver.com for schedule and information. Contact Fred at fcwilbur@verizon.net or write to P O Box 425, Lovingson, VA 22949.

Seat Weaving Supplies

CHAIR CANE & SPLINT, Shaker tape, fiber & natural rush. Complete line of basketweaving supplies. Royalwood Ltd., 517-WW Woodville Rd, Mansfield, OH 44907. 800-526-1630.
www.royalwoodltd.com.

Classified rate is \$6.00 per word, 15-word minimum. Order must be accompanied by payment; ads are non-commissionable. Send to: Popular Woodworking Magazine, 10151 Carver Road, Suite 200, Blue Ash, OH 45242 or Don Schroder, d.schroder@verizon.net. Phone: 610-821-4425, Fax: 610-821-7884.

ADVERTISER'S INDEX

	PAGE#	CARD#	WEBADDRESS
1-800-Bunkbed	19	97	1800bunkbed.com
Acanthus Workshop	57	1	acanthus.com
Ali Industries	5	55	shopsmithabrasives.com
Beall Tool Company	56	2	bealltool.com
Bessey Tools of North America	7	46	besseytools.com
Bloxygen	57	3	bloxygen.com
Craftsman Plans	56	-	craftsmanplans.com
Craftsman Studio	56	5	craftsmanstudio.com
Custom Branding Irons	9	93	branding-irons.biz
Di Legno Woodshop Supply	57	6	dlws.com
DR Power Equipment	19	-	drpower.com
Easy Wood Tools	7	39	easywoodtools.com
Epilog Laser	Cvr4	56	epiloglaser.com
Frederick Wilbur Woodcarver	57	15	frederickwilbur-woodcarver.com
Furniture Institute of Massachusetts	56,57	16	furnituremakingclasses.com
Gregory Paolini Designs	57	19	gregorypaolini.com
GreX USA	19	20	grexusa.com
Grizzly Industrial	Cvr2,1,2	57	grizzly.com
Harbor Freight	21	76	harborfreight.com
Highland Woodworker, The	7	91	thehighlandwoodworker.com
Highland Woodworking	11	22	highlandwoodworking.com
Infinity Tools	19	23	infinitytools.com

	PAGE#	CARD#	WEBADDRESS
Jim Bode Tools	57	24	jimbodetools.com
John Campbell Folk School	57	no	folkschool.org
Keller & Company	56	26	kellerdovetail.com
Lake Erie Toolworks	56	70	lakeerietoolworks.com
Lie-Nielsen Toolworks	11	29	lie-nielsen.com
Oliver Machinery	17	94	olivermachinery.net
Oneida Air Systems	9	35	oneida-air.com
Osborne Wood Products	9	36	osbornewood.com
Philadelphia Furniture Workshop	56	-	philadelphiafurnitureworkshop.com
RadarCarve	11	38	radarcarve.net
Rikon Power Tools	17	42	rikontools.com
Royalwood Ltd.	57	-	royalwoodltd.com
Shellac.net	57	-	shellac.net
Wall Lumber	11	47	walllumber.com
Whitechapel Ltd.	56	48	whitechapel-ltd.com
Woodcraft	Cvr3	49	woodcraft.com
Woodfinder	56	-	woodfinder.com
Woodworker's Source	56	53	woodworkerssource.com
Woodworker's Supply	9	54	woodworker.com

The Hole Story

Discover a bit about clean, accurate boring.

There are many tools in modern woodworking you can use to bore holes: powered drills (both corded and cordless), drill presses, hand-powered eggbeater drills, braces and more.

Drill presses are the powered method of choice when accuracy is important. Battery-operated drills are convenient and fast. Corded drills are fast, never need charging and are usually lighter in weight than their battery-powered brethren. Eggbeater drills are awesome when you need just a few holes. Braces are ideal for drilling large-diameter holes with ease, and making holes at odd angles (as in chairmaking) without a lot of crazy jiggery.

Level & Plumb

A drill press excels at boring accurate holes at a predetermined angle—but so can you; it just takes a little practice. I assume the majority of beginning woodworkers use an electric drill—so let's consider the proper grip.

Like a handsaw or handplane, a drill is best used with a three-fingered grip. Use your middle finger to depress the trigger; your index finger should point along the side of the tool, in the direction that you are drilling. Your pointing finger helps to cue your body to head in the same direction. I realize it sounds a little bit nutty—but try it out; you'll discover it works for just about any tool that you grip with one hand.

It's also important to realize that for many holes, there is a critical and non-critical axis, and to align your tool and body on the critical axis.

Let's use clearing waste from a mortise as an example. Looking from the end of the workpiece, what's important is that you don't let the bit list side to side; front to back is OK (except at the



Pick your bit. All of these bits can drill holes in wood—so which should you choose? From left are pictured a Forstner bit, twist bit, brad-point bit and spade bit. See the chart on the next page for quick reference on using each.

AUGER BITS

Auger bits are used in a brace and come in two common patterns: Irwin (top) and Jennings. Both have self-feeding lead screws to help locate the cut and drill a lead hole; lead screws on both come in three iterations: fine (hardwoods), medium (hard and softwoods) and coarse (softwoods). Both patterns have two sharp spurs to score the circumference and two cutting lips to bore the hole. Unlike the Jennings, the Irwin has a solid central shaft; for every three spirals in the cut for the Jennings there are two spirals for the Irwin. The latter is less likely to clog when boring deep holes—but due to its wider spiral spacing, it's more likely the beginning borer will ream a hole while cutting. Like all bits, augers must be kept sharp and rust-free to work well. They are typically available in 1/4"-1" diameter.

—MF



Two common patterns. The Irwin-pattern bit (top) has more widely spaced flutes than the Jennings-pattern bit. Note, too, the difference in the lead screws. The coarse lead screw on this Irwin is for softwood; the fine thread on this Jennings is for hardwood.

ends). Thus, side to side is the “critical axis.”

Sight your bit against a try square centered at the far end of the mortise (or draw a centerline beyond the end

of the mortise to guide you), and align your body in front that guide. The try square or line, along with your body position, will help you keep the tool in the critical axis.

Twist Bits

These bits are designed to cut metal, but are commonly and successfully used on wood, too. It can be tricky to get a twist bit started in a precise location and it may follow the grain in the cut. To combat that, use an awl or other pointy tool to start a hole exactly where desired. Twist bits can cause splintering, particularly on the backside of work.

- Common sizes: 1/32"- 5/8"



Brad Point Bits

These are the best choice for most small-diameter holes in woodworking. The brad point allows you to locate the bit precisely, and keeps it from wandering. The spurs at the tip cut a cleaner hole and reduce splintering both on the entry and backside. (Also, bit sizes up to about 1/4" can be use with eggbeater drills).

- Common sizes: 1/16"- 5/8"



Spade Bits

These bits are best for hogging out waste quickly when a clean hole is not an issue; they usually cause bad splintering, particularly on the backside of a workpiece (and some splintering on the front) – though scribing the cut first in reverse alleviates this to some degree. Inexpensive spade bits can be easily ground for custom sizes.

- Common sizes: 1/4"- 1 1/2"



Forstner Bits

These bits cut clean, accurate flat-bottomed holes in larger diameters. The lipped edges shear material to cleanly define a hole's edge and the center point makes it simple to locate the hole's center. Due to the force needed to make the cut, Forstner bits are best used in a drill press or brace.

- Common sizes: 5/16"- 2"



Cut a Clean Hole

If you need a hole in a show surface and are worried about splintering, back up the cut with a piece of scrap (you can also apply a piece of painter's tape atop the hole location before deploying the drill, which is moderately effective). Better yet, scribe the cut first by slowly moving the bit in reverse by hand – or, if at the drill press, by lowering the bit onto the wood then rotating the workpiece.

Pilot Hole vs. Clearance Hole

You've no-doubt seen the instruction to “drill a pilot hole.” That's simply a small hole centered in the cut to help lead the way for what comes next – a larger-diameter hole, a nail or a screw. A pilot hole is tight enough that the next bit (or hardware) cuts into the hole's walls.

A clearance hole, however, clears a wide path for what follows, such as a bolt, or a screw through the top of two boards being joined together.

Conclusion

Despite the headline, this is obviously not the whole story on bits and boring – but I hope it's enough to get you started on the path to drilling success. **PWM**

Megan is the editor of this magazine. She can be reached at 513-531-2690 x11348 or megan.fitzpatrick@fwmedia.com.

ONLINE EXTRAS

For links to all online extras, go to:

- popularwoodworking.com/aug13

VIDEO: Watch as the author demonstrates how to reduce splintering while boring.

IN OUR STORE: “Become a Better Borer,” an article by Christopher Schwarz on using auger bits and braces.

About This Column

Woodworking ESSENTIALS

Woodworking Essentials takes a close look at the tools, materials and processes of woodworking.

Our products are available online at:

- ShopWoodworking.com

Logs to Lumber

With sweat equity and a few simple tools, you can split strong, stable stock.

Though sawn lumber was available to 17th- and 18th-century European woodworkers in Colonial America, many American craftsmen split wood to produce stock for furniture. Rive or split marks are typical of 17th-century furniture and not at all uncommon on the finest pieces of “high style” late 18th-century American furniture.

For early craftsmen, splitting logs into lumber offered several advantages. Splitting could be done where the log was felled, saving the cost of hauling logs to saw yards. Because careful splits follow the grain of the wood, the resulting boards typically dry straighter. Perfectly quartered boards are both more dimensionally stable and easier to plane than modern quartersawn stock. For chairmakers, riven stock allowed them to bend wood more successfully and produce thin, high-strength spindles.

As we often learn in this column, not much has changed in the last 200 years. Logs can still be split efficiently with just a few simple tools. Moving logs or bringing in sawyers with specialized equipment is still expensive, and riven stock still behaves the same as ever.

The key to splitting logs like these is to set reasonable expectations for their use; it’s not wise to try to compete with the local mill. I use logs to produce lumber that I can’t buy anywhere else.

You can easily split a 4"- or 6"-thick slab for a workbench top. Philadelphia cabinetmakers split white cedar for perfectly quartered drawer parts, so even short sections of pine or other softwoods can be valuable. There are tons of tool parts better split than sawn. Tool handles, jaws for vises and clamps, plane blanks, saw handles and even simple items such as sawhorses are all best made from riven lumber. And



A gift from the storm. This 22"-diameter, 9'-long white oak log is from a tree felled in my yard by Hurricane Sandy. After splitting it, I'll be riving boards to use in projects for my home. Riven oak is perfectly radial and thus dimensionally stable and very strong.

if you have a lathe, you can add a pile of projects that are best turned from wood split from logs.

But there is no such thing as free wood. We purchase lumber with either money or sweat.

First Crack

The first step in the process is selecting the log. Different species split differently and have different uses. Experience and your particular needs will dictate when you should pass on a log. Where a tree is located, how it stood and how it grew will give you clues about the lumber inside.

Forested trees typically grow straighter and with fewer branches because they are anxious to reach the light at the forest’s canopy. Trees that stand alone sometimes twist to catch as much sunlight as possible or to counter prevailing winds. Bark can be an indi-



Get a handle on the material. I used the wedge in the 8 o'clock position as a handle to roll the log as I examined it. Once I had the log positioned, I set the first wedge to begin the split.

cator of what is happening under the surface. Spiral shapes in a tree’s bark can indicate a twisted log. But I’ve been fooled by straight-looking bark that concealed twisted wood inside.

Before starting the first split, roll the log to check for nails or knots. When I see a single large knot, I roll the log to place the knot to the 3 or 9 o'clock position then start the split at 12 o'clock. The first wedge is placed in the bark, aimed at the heart along a ray – the lines that radiate from the heart to the sap and bark. Note that the rays are not always straight. The idea is to split the log initially along the rays. Hammer a



Below the bark. Oak's rough bark conceals a split fairly well. I shave the bark away from the crack using my broad hatchet like a chisel so I can see what is happening.

wedge in until a crack begins to propagate beyond the wedge's tip in both the end grain and the long grain.

Follow the Split

Set the next wedge in the crack made by the first or just beyond it. I prefer to set the wedges at least a foot apart. To remove them, you have to knock them sideways, so leave yourself plenty of room. If the crack appears to be twisting round the log, there's generally little you can do about it. You must follow the ray plane. For this reason, it's important to remove the bark so you can see the crack made by your first wedge.

All Along the Log

Continue the process of setting wedges. I use a minimum of three metal wedges, leapfrogging the first as the second two open up the crack. You can work your way along the entire length of a log fairly easily.



Glut work. A dogwood glut, fashioned in the shape of a metal wedge, holds the crack open. This allows me to chop the fibers holding the halves together without risking the edge of my hatchet.



Leapfrog. I use three wedges when splitting logs. I'll set the third at the end of the crack made by the second, then continue by leapfrogging the first wedge (which usually releases with a few taps to either side in the direction of the split).

White oak is special in the "cross links" it forms within its long grain. This makes it more difficult to bend, generally stiffer than red oak and considerably more difficult to split. When splitting white oak, you can successfully split a log in half and not be able to separate the halves. When this happens, use wooden wedges (properly called "gluts"). Mine are made from the shaft of a small dogwood tree, a split-resistant species that can be hammered fairly aggressively. Replacing the metal wedges with gluts allows you to cut the cross-linking fibers without worry of damaging your hatchet.

With my log halved, I'll soon split the remaining pieces until I have manageable, usable boards. Then, I'll coat the end grain with wax or some end-grain sealer before stacking the pieces up off the ground to dry. (Stickering is more important when storing boards that don't follow the grain of the wood.



An afternoon of hard work has paid off. Beautiful, straight, clear white oak awaits my next project.



Fibers. White oak has cross-linked grain. These fibers are very strong and must be cut to separate the halves of this log.

There is little or no propensity for riven wood to warp. But airflow is important to prevent rot or fungus that can ruin your stock.)

Future Furniture

This tree was uprooted by the hurricane that hit the Northeast last fall. It fell toward the storm and away from my home, sparing us from roof damage or injury. There is something fitting about using this tree's wood to furnish my house and it has presented the opportunity for me to reacquaint myself with the material we all love in a very intimate way. I don't think woodworking gets any better than that. **PWM**

Visit Adam's blog at artsandmysteries.com for more discussion of traditional tools and techniques.

ONLINE EXTRAS

For links to all online extras, go to:

■ popularwoodworking.com/aug13

BLOG: Read the Arts & Mysteries blog.

IN OUR STORE: Newly updated, "The Arts & Mysteries of Hand Tools" on CD.

About This Column

ARTS & Mysteries

Adam covers 18th-century shop practices and tools in his own, inimitable style. The phrase "Arts & Mysteries" refers to the contract between an apprentice and master – the 18th-century master was contractually obligated to teach apprentices trade secrets of a given craft (and the apprentice was expected to preserve those "mysteries").

Our products are available online at:

■ ShopWoodworking.com

Revive or Restore?

Discover how (and when) to give old, deteriorated finishes new life.

As finishes age, they deteriorate. First they dull, then they begin showing small cracks (called “crazing”). The culprit of this degradation is oxygen, which attacks the finish very slowly. Crazing is accelerated so much by ultraviolet light and heat, however, that it’s more helpful to think of these as the real causes.

As the deterioration worsens, not only does the finish look bad, it loses its primary function of protecting the wood from contact with liquids. Excessive moisture getting to the wood leads to veneer cracking, as well as joint and veneer separation, splits and warps.

Old furniture with a deteriorated finish usually ends up in a landfill. This is the reason the “Antiques Roadshow” message, “Don’t refinish,” is so unfortunate. Refinishing saves old furniture.

But old finishes can often be “revived,” and most methods are quite easy. You just need to have some idea of situations and ways to proceed.

The Deterioration Process

As light and heat attack a finish, they begin breaking up the surface molecules. At first, you don’t see the separations, you see just the dullness caused by light being randomly reflected. Eventually the crazing becomes visible to the naked eye.

The process occurs slowly and there are many stages along the way. In all cases the depth you can see into the wood is reduced, more so the worse the crazing.

There are four primary reviving procedures which you can use at any stage:

- Apply furniture polish or paste wax
- Clean and apply more finish
- Sand the old finish smooth and rub out
- Sand smooth and apply more finish.



Crazed finish. Reviving a finish is a great solution in many situations where it has deteriorated. But be aware that the deterioration can be so bad that nothing short of stripping and refinishing can be done successfully. This example of a 100-year-old drawer front is such a case.

If one approach doesn’t work to your satisfaction, try another. Keep in mind that the worst-case scenario would be that nothing works well and you end up stripping and refinishing. You aren’t ruining anything.

Furniture Polish & Paste Wax

Furniture polishes and paste waxes add shine, reduce scratching and restore depth as long as the finish isn’t badly crazed. The most effective furniture polishes are those that contain silicone. This includes most available aerosols.

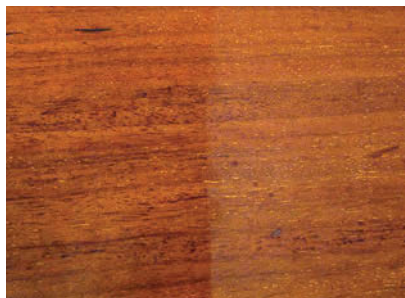

Wet to see depth. To see what a revived finish will look like, wet the surface (left) with mineral spirits or furniture polish. Neither will damage any finish and they flow out better than water.

Unfortunately, silicone has gained a bad reputation from furniture conservators, refinishers and antique dealers who hate having to deal with fish-eye problems (small craters in applied finishes) that silicone can cause. But homeowners and housekeepers love silicone polishes, which have close to a 90 percent market share, because they last much longer and add the most depth and scratch resistance.

Furniture polishes don’t work well on crazed surfaces, however, because the liquid highlights the cracks. For crazed finishes, paste wax is by far the better product to use.

The easy way to apply paste wax to large surfaces is to put a lump of the wax inside a cloth and wipe it over the surface. The cloth limits the amount of wax you are depositing so removing the excess is easier.

When the shine of the applied wax disappears (due to solvent evaporation) and the wax develops a noticeable resistance, rub off all the excess with a soft, clean cloth. Refold and change the cloth often so you transfer the wax to the cloth and not just spread it around.

Clean & Apply More Finish

Surfaces must be clean to apply more finish successfully. You can clean an old finish with any number of products, including soap and water, household ammonia and water, or a solvent such as mineral spirits or naphtha. Soap and water are best for removing sugary dirt. Solvents are best for removing grease, wax and furniture polish. About a cup of household ammonia in a bucket of water is effective for removing both types of household grime.

Applying more finish can sometimes be tricky because of the likelihood of silicone contamination. Two good solutions are to apply a first coat of shellac, which will “seal off” the silicone left on the surface, or apply a wipe-on finish such as oil or wiping varnish – with very little build, fish eyes don’t have the possibility of developing.

To reduce the gloss of any finish, rub with #0000 steel wool. Use an oil, soap and water or wax lubricant to soften the scratching.

For spraying lacquer, you can add fish-eye eliminator instead of applying a first coat of shellac. But spray very



Thin finish. Applying a thin coat of finish avoids the fish-eye problems caused by silicone furniture polishes having been used. Padding wiping varnish, as I’m doing here, can be done on site.

light coats at first so that the solvent in the lacquer doesn’t have time to blister the old finish.

Sand & Rub out

If the old finish is supple and thick enough, you can sand and rub it out with increasingly finer-grit abrasives, just as you would a newly applied finish.

Begin with the finest-grit abrasive that will efficiently remove whatever problems exist. Think #320-, #400- or #600-grit sandpaper. Don’t use a sanding block unless you are sure the surface is perfectly flat.

With the problems removed, switch to #0000 steel wool or another abrasive to achieve the sheen you want.

Sand & Apply More Finish

In most cases, if the finish is crazed, it won’t be supple enough to rub out. You’ll need to apply more finish following the instructions above, after you have sanded out the crazing. If the crazing goes through to the wood, the best course of action is to refinish. Applying more finish won’t hide the crazing when you look straight into the finish.

Color Problems

Often there are color problems to deal with. White rings are superficial and will be removed when you sand or rub out the finish. Black rings are in the wood and can’t be removed without removing the finish first. If that is the case, use oxalic acid to bleach and remove the marks.

There are two types of lighter-colored marks caused by scratches or when you rub through the finish: marks that go through to the wood and marks that remove color that was in the finish but don’t go to the wood.

In the first case, you can usually replace the color by wiping with a colored wax (many imported brands come in colors), a wiping stain or water-soluble dye, or a widely available product called Howard Restor-A-Finish, which comes in colors.



Sand to remove problems. Sanding removes surface crazing and other problems. Use the finest grit that will do the job efficiently. Here I’m using #600-grit sandpaper.

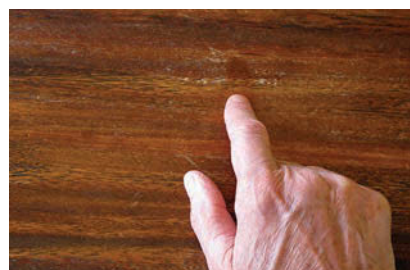

Test for color. A simple finger wipe with a little saliva (or other liquid) will show if more finish will restore the color. If the color isn’t restored, you will need to add stain or paint in more color.

In cases where the damage doesn’t go to the wood, you’ll need to figure a way to paint in the color, usually with a stain or glaze, or make your own with colored powders mixed with shellac or lacquer.

Small areas are usually easy to match adequately. Large areas can be impossible. **PWM**

Bob is author of “Flexner on Finishing” and “Wood Finishing 101.”

ONLINE EXTRAS

For links to all online extras, go to:

■ popularwoodworking.com/aug13

ARTICLES: You’ll find many free finishing articles on our web site.

IN OUR STORE: “Flexner on Finishing” – 12 years of columns illustrated with beautiful full-color images and updated, and “Wood Finishing 101.”

Our products are available online at:

■ ShopWoodworking.com

Conquer Finish Fears

A stay-the-course attitude turns phobia into appreciation.

I don't know many woodworkers who enjoy finishing. We will gladly spend an eternity devising a jig to help with an operation that we'll perform only once. Time stands still when we're at the lumber mill looking for that elusive, perfect board for a project so far down on the "to do" list that it may never be built. And I'm sure I'm not the only woodworker who endlessly tweaks a new design, agonizing (my wife says obsessing) over every insignificant detail. At the mention of finishing, however, our eyes glaze over and we go to that happy place in our minds where solvents don't exist and a magnificent French polish magically appears on our furniture.

I've felt exactly this way about finishing and I don't know why. I don't have any nightmarish finishing experiences in my past. In fact, most of my finishing has been successful if not professional quality, so it isn't negative reinforcement causing my lack of enthusiasm. And yet, there it is – a nearly unshakable, negative attitude toward a vitally important part of a hobby about which I am passionate.

I recently completed a Stickley-inspired kitchen table. I spent an eternity devising ways to cut the joinery for the top and to create the tile inlay. My friend, Jim, and I drove two hours, each way, to Frank Miller Lumber then spent a couple more hours searching through pallets of quartersawn white oak.

Another friend, Tom, looked at numerous versions of this design, patiently offering his critique of each.

Construction on the table proceeded quickly and without incident. I enjoyed every hour spent in the shop jointing, planing and cutting joinery. Even the

glue-up went smoothly and with a minimum of perspiration.

The finish for this piece involved several steps: Apply a dye followed by a sealer, then a glaze and finally the top coat. Although this is a little more involved than the oil finishes I often use, I steeled myself to proceed.

The dye went on easily enough. The sealer coat was no problem. At this intermediate stage, the finish didn't look particularly good. It was a little scary, in fact. Several weeks of hard work was obscured by a layer of hideous maroon.

My wife sees recipes as suggestions. She'll substitute liberally, or even omit an ingredient if we don't have it. I stick to recipes as if they are the law. That is just what I did in this case. And a funny thing happened.

The gel-stain-glaze step transformed the table. In a matter of minutes it went from ugly maroon to a beautiful Arts & Crafts finish. Several coats of wiping varnish later, I had a new place for my family to gather each evening.

This table is not one of the more challenging pieces I've made, but it is one of my favorites – the finish is a big part of the reason. The mahogany and cherry that I typically use are beautiful without the benefit of complex finishes, but white oak, even nicely

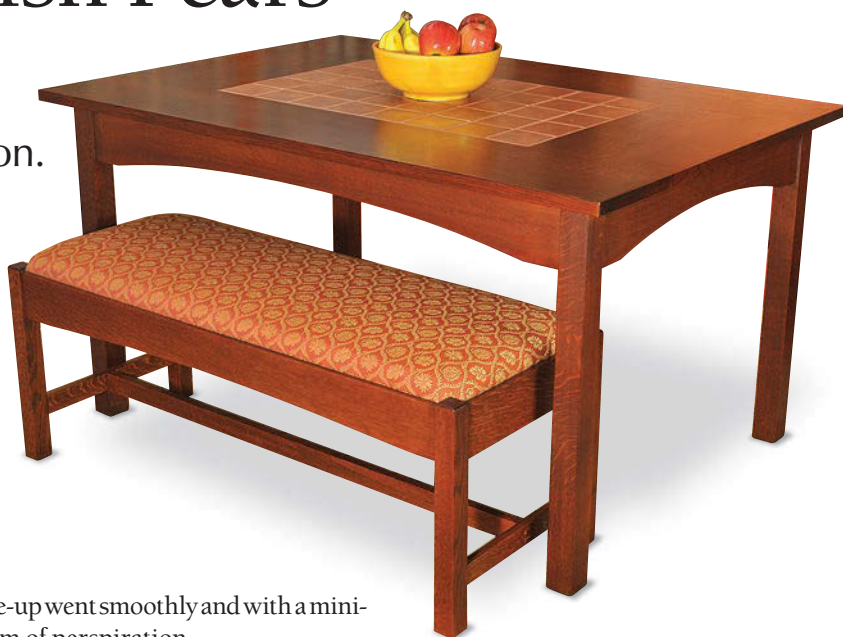

figured quartersawn white oak, needs a little more help. And this particular recipe is fantastic.

So, with this kitchen table as the impetus, I'm turning over a new leaf with respect to finishing. I may never love it. It will likely never be my favorite part of woodworking. But I've gained a new appreciation for it now that I've realized what it does. Finishing turns the results of our hard work into beautiful, functional works of art. It seems that any woodworker should enjoy that. **PWM**

David is the author of "Greene & Greene Furniture: Poems of Wood & Light." His latest venture, photography of the Swiss Alps, can be viewed at his web site: thealps.wood-and-light.com/en.

ONLINE EXTRAS

For links to all online extras, go to:

■ popularwoodworking.com/aug13

TWITTER: Follow us on Twitter @pwweditors.

IN OUR STORE: Get everything you need to finish your woodworking projects like a professional in "Flexner on Finishing."

Our products are available online at:

■ ShopWoodworking.com

Take The Hassle Out Of Dust Collection with Oneida's Super Dust Deputy

Oneida's Super Dust Deputy can turn your inefficient single-stage bag collector into a high efficiency two-stage cyclone system that separates 99% of wood waste, reducing filter maintenance and eliminating dusty bags to empty. The Heavy-Duty Welded Steel Cyclone is a great addition to an existing dust-collection system, while the new Lightweight Molded Resin Cyclone is more mobile. Drum kits are optional, or get creative and use your own!

- Retrofits 1 HP – 3 HP Single-Stage Dust Collectors
- 5" OD Inlet And 6" OD Outlet
- Compact Footprint With Easy Installation



154755 Super Dust Deputy Metal Cyclone (Mounted On Optional Drum)



Super Dust Deputy
Molded Cyclone
158396



17-Gal Drum For
Super Dust Deputy
154756

For A Free Catalog Or To Find Your Local Woodcraft Store, Visit woodcraft.com Or Call 800-225-1153. 13PW08P
For Information On Woodcraft Retail Franchise Opportunities, Visit woodcraftfranchise.com

ENGRAVE IT.

INLAY IT.

SELL IT.



The finishing touches start here



Cabinet Inlays



Customize Products



Custom Birdhouse

MADEINUSA

A Versatile System for a Modern Woodshop

- Increase the value of all your woodworking projects with custom laser work.
- Engrave stunning photos, text and graphics with a touch of a button.
- Create custom projects with ease – jewelry boxes, humidors, cabinets and much more!

Systems Starting at \$7,995



To request a brochure, DVD, and samples, contact us at:
epiloglaser.com/popwood • sales@epiloglaser.com • 888-437-4564