

Woodsmith®

EXCLUSIVE Triple Bonus

See Back Cover for Details

WOODWORKING

Tips, TricksTM & Jigs

Techniques

for strong & sturdy joinery

Essential Skills

for more precise results

Top Tools & Tricks

for accurate layouts

Power Tool Secrets

for better projects

Creative Home Group
 General Manager: Donald B. Peschke

Editorial Media Director: Bryan Nelson
 Managing Editor: Vincent Ancona
 Senior Editors: Wyatt Myers, Phil Huber
 Associate Editor: Robert Kemp
 Assistant Editor: Erich Lage

Executive Art Director: Todd Lambirth
 Senior Graphic Designer: Bob Zimmerman
 Senior Illustrators: Dirk Ver Steeg,
 Harlan V. Clark, Peter J. Larson
 Graphic Designer: Becky Kralicek

Creative Director: Ted Kralicek
 Assistant Design Director: Chris Fitch
 Project Designer/Builder: John Doyle
 CAD Specialist: Steve Johnson
 Shop Craftsman: Dana Myers

Photographers: Crayola England,
 Dennis Kennedy
 Associate Style Director: Rebecca Cunningham
 Senior Electronic Image Specialist: Allan Ruhnke
 Production Assistant: Minnette Johnson
 Video Director/Editor: Mark Hayes

Single Copy Sales: Lisa Trom, Paige Rogers

Woodworking Tips, Tricks & Jigs is published by Cruz Bay Publishing, Inc.
 2200 Grand Ave., Des Moines, IA 50312.
 Canada Post Agreement 40038201.
 Canada BN 84597 5473 RT.
 ©Copyright 2016 Cruz Bay Publishing, Inc.
 All rights reserved. No part of this book may be reproduced in any form or by any electronic or mechanical means, including information storage and retrieval devices or systems, without prior written permission from the publisher, except that brief passages may be quoted for reviews.

Woodsmith® is a registered trademark of Cruz Bay Publishing, Inc.

For subscription information about Woodsmith, visit us online at: Woodsmith.com or call (800) 333-5075

A Supplement to Cruz Bay Publishing, Inc.

2200 Grand Ave., Des Moines, IA 50312
 Printed in U.S.A.



ACTIVE INTEREST MEDIA

CHAIRMAN **Efrem Zimbalist III**

PRESIDENT & CEO **Andrew W. Clurman**

EXECUTIVE VICE PRESIDENT &

CHIEF FINANCIAL OFFICER **Brian J. Sellstrom**

EXECUTIVE VICE PRESIDENT, OPERATIONS **Patricia B. Fox**

power tool Tips & Tricks



Auxiliary Miter Fences 6

The secret to flawless, accurate crosscuts at the table saw is to add a simple plywood fence and stop block to your miter gauge.

Table Saw Sleds 8

These 4 handy table saw sled designs will handle all your cutting needs, from crosscuts to dados and miters.

Tips & Techniques 12

Router Tips & Tricks 22

Get more from your router with this handful of fundamental techniques that will be sure to yield better-looking projects.

simple shop Solutions



Small-Shop Ideas 26

Have a small shop? No problem. These handy layout and storage strategies will help you make the most of a small space.

Tips & Techniques 28

Creative Clamp Storage 42

A woodworker can never have too many clamps, but the dilemma is where to store them. Here's where you'll find the answers.

SHOP SAFETY IS YOUR RESPONSIBILITY

Using hand or power tools improperly can result in serious injury or death. Do not operate any tool until you read the manual and understand how to operate the tool safely. Always use all appropriate safety equipment as well as the guards that come with your tools and equipment and read the manuals that accompany them. In some of the illustrations in this book, the guards and safety equipment have been removed only to provide a better view of the operation. Do not attempt any procedure without using all appropriate safety equipment or without ensuring that all guards are in place. Cruz Bay Publishing, Inc. assumes no responsibility for any injury, damage, or loss suffered as a result of your use of the material, plans, or illustrations contained in this book.

hands-on Techniques



44

Hinge Mortise Tips & Tricks 46

Hinge mortises are required in many projects, and it can be tough to get them right. Not with these simple strategies.

Installing Drawer Slides 48

Aligned, smooth-sliding drawers require accurate drawer slide placement. Luckily, it only takes a few simple steps.

Tips & Techniques 50

7 Tips for Perfect Panels 60

Transform basic boards into a great-looking, seamless solid-wood panel by following the approaches covered here.

better layouts & Cuts



62

Tools for Prepping Stock 64

From rough-sawn lumber all the way to project-ready workpieces, we've got you covered with advice every step of the way.

Secrets to Cleaner Cuts 68

Flawless, glass-smooth cuts at the table saw are achievable with just a few simple accessories and add-ons.

Tips & Techniques 70

Straightedge Guides 78

Basic hardboard and plywood combine to create one of the handiest jigs that you can have around your shop.

perfect joinery & Assembly



80

Mortises: Good to Great 82

There's a difference between a basic mortise and one that's smooth and perfectly square. Here's how it's done.

Better-Fitting Tenons 84

The other part of the equation with a mortise and tenon joint is also an easy area to get great results with the right method.

Tips & Techniques 88

Getting Ready for Glueup 96

Perfect projects all come down to the right approach during the gluing and clamping process. These tips will have you prepared.

Versatile Miter Jig 98

This simple shop-built table saw sled will greatly enhance your ability to cut accurate, tighter-fitting miter joints.

contents





Power Tool Tips & Tricks

Your power tools are the cornerstone of your shop and the primary spots where your projects begin to come together. This collection of tips and techniques will help you make the most of them.

AUXILIARY MITER FENCES6

4 TABLE SAW SLEDS8

TIPS & TECHNIQUES.....12

ROUTER TIPS & TRICKS22



auxiliary Miter Fences

With a few simple additions, you can transform your table saw's basic miter gauge into a precision crosscutting machine that produces smooth results.

Right out of the box, a new table saw is equipped with what you need to get started making cuts and building projects. But I've found that making a few upgrades can deliver safer, easier, and more accurate cuts.

One of the first candidates for an upgrade is the miter gauge. The miter gauge is the counterpart to the rip fence for guiding a workpiece through the blade. It's used for crosscuts, miters,

cutting panels to length, as well as joinery like dadoes and rabbets.

Unlike the rip fence, the miter gauge isn't locked in position to make a cut. It travels with the workpiece riding in a slot milled in the saw table. The head is adjustable for cutting angles on the end of a workpiece (or angled joinery).

LIMITATIONS. The problem is a stock miter gauge leaves a lot to be desired. The head on most miter gauges isn't very wide, as shown in the lower left photo. This doesn't provide much support for cutting a long workpiece. Also, during crosscutting, the back edge of a workpiece is prone to tearing out as the blade completes the cut. Finally, there's no good way to quickly cut multiple parts to the same length.

A PLYWOOD FENCE. Thankfully, the resolution to all of these issues is simple and inexpensive. It starts with an auxiliary miter gauge fence. The fence is a strip of plywood that's screwed to the miter gauge, as in the photo above. In fact,

most saw manufacturers anticipate this by including holes or slots for screws to attach the fence. The fence increases the bearing surface for greater control and backs up the workpiece, as well.

This humble strip of plywood has a lot of benefits packed into it that can be easily overlooked. For starters, a small rabbet along the bottom edge helps prevent dust and chips from interfering with the placement of the workpiece, as shown in the drawing on the next page.

I applied a strip of adhesive-backed sandpaper to the face to provide a non-slip surface to assist in holding the workpiece steady during the cut. You'll also notice that the fence is attached so that it extends past the waste side of the blade. This allows you to push waste pieces safely clear of the blade. In addition, the kerf created by the blade serves as a handy reference for lining up a layout line for accurate cuts.

STOP BLOCK. At the risk of sounding like a late-night infomercial —



Basic Gauge. The miter gauge that comes with your table saw is only the starting point for making accurate crosscuts.

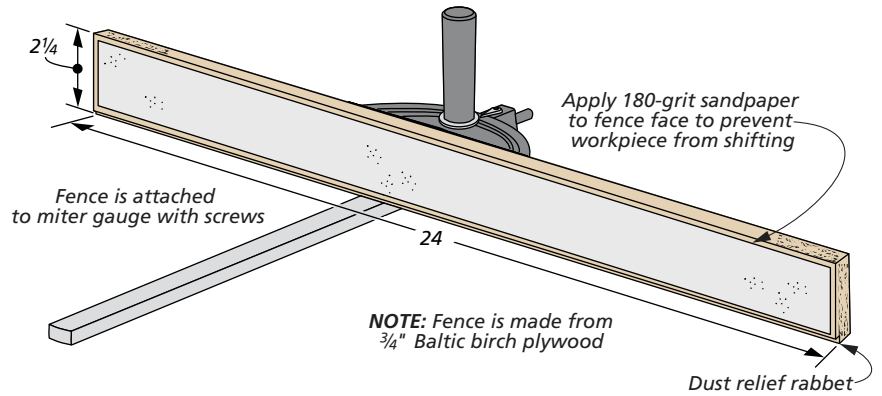
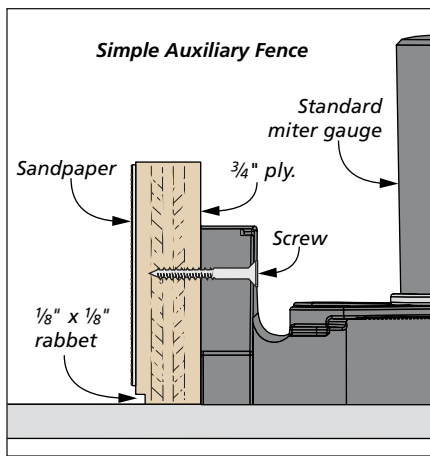

But wait, there's more. Cutting one piece to a given length is relatively easy to accomplish with a miter gauge and a clear layout line. But many projects require cutting several parts to an identical length. Laying out each cut and

lining it up with the kerf in the fence is a tedious task that's prone to error. The key to doing it accurately and quickly is a small hardwood stop block, as shown in the photos and drawing below.

Even this simple stop block is tricked out with details. A wide, shallow rabbet

on the back face creates a lip on the upper back edge. This makes the stop block less likely to shift out of place when bumping a workpiece up to it. Like the fence, the stop block has dust relief. Here, it's a chamfer on the lower edges.

The final detail I want to highlight is a countersunk screw on the edge. The purpose of the screw is to allow you to fine-tune the length of a part without repositioning the stop block. This means you can sneak up on the final length of a workpiece by making subtle adjustments with a screwdriver. The box below shows a couple of commercial accessories that add a few other benefits to any shop-built fence.

In less than a half hour and with a couple scraps, you can take your table saw to the next level of accuracy. After making these upgrades, you'll find the return on your investment is pretty significant. **W**



Microadjuster. To shorten a board in small increments, use a screwdriver to back out the screw in the stop block a little at a time.

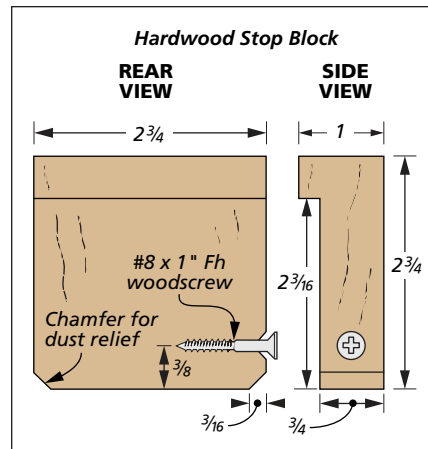

Upgrade: T-Track & Flip Stop



You can improve your miter gauge even more by adding a length of T-track. I used *Kreg's Top Trak* (left photo). The advantage of this track is that you can use a flip stop. This lets you cut longer parts without altering the stop setting. Simply flip the stop up out of the way (right insert photo). The T-track mounts to the back of the fence. You can attach an adhesive-backed measuring tape to simplify setting the stop.

Note: Depending on the height of your miter gauge, you may need to add a 1/4 inch hardboard spacer between the miter gauge and fence to prevent the track from contacting the miter gauge.



Easy Adjustments. A flip stop allows you to cut other parts to rough length without losing your setting. Just pivot the stop block up and out of the way (inset) to make a cut.



essential upgrades

Table Saw Sleds

If you want to increase the capacity, efficiency, and accuracy of your table saw for making crosscuts, then one of these sleds should fill the bill.

A critical part of every project is making clean, square crosscuts. This leads to snug-fitting joinery and a better-looking project. So it comes as no surprise that most woodworkers rely on their table saws to tackle this task. A well-tuned saw with a sharp blade is a

good starting point. But adding a crosscut sled can further simplify the process and aid in giving you predictable, high-quality cuts. While you may think of a sled as only helpful for cutting panels, there are some good reasons for using one for nearly any size workpiece.

The main benefit of using a sled is that the workpiece rests on the surface of the sled instead of sliding across the saw table. This means the piece won't shift or catch during a cut, so your odds of getting a cleaner cut increase. Also, the base of the sled and the fence provide

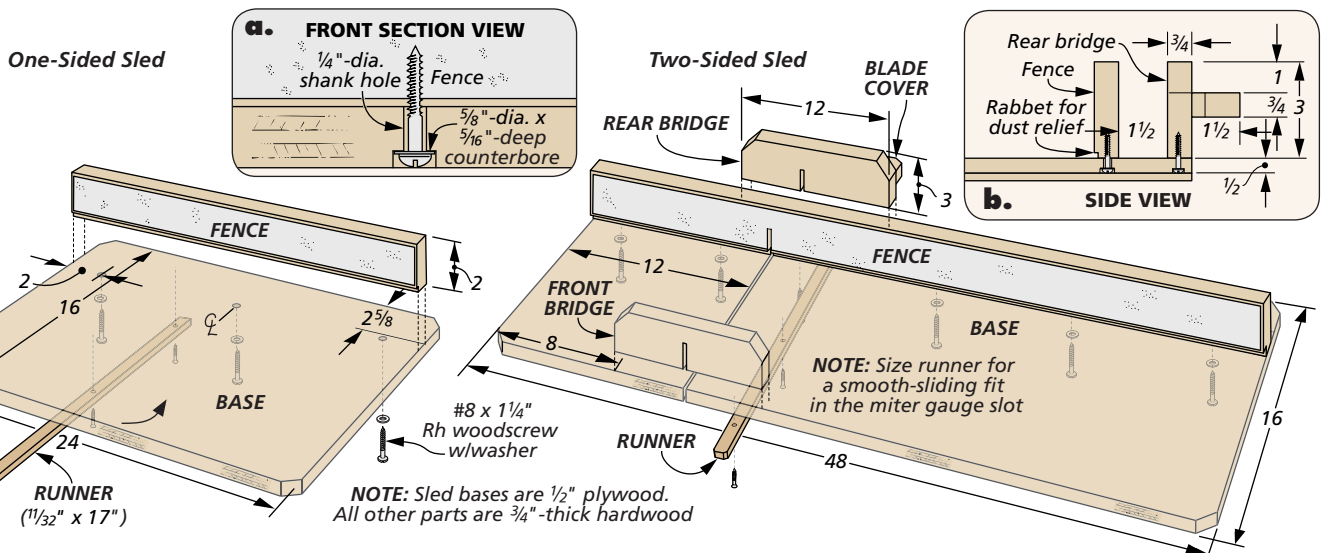

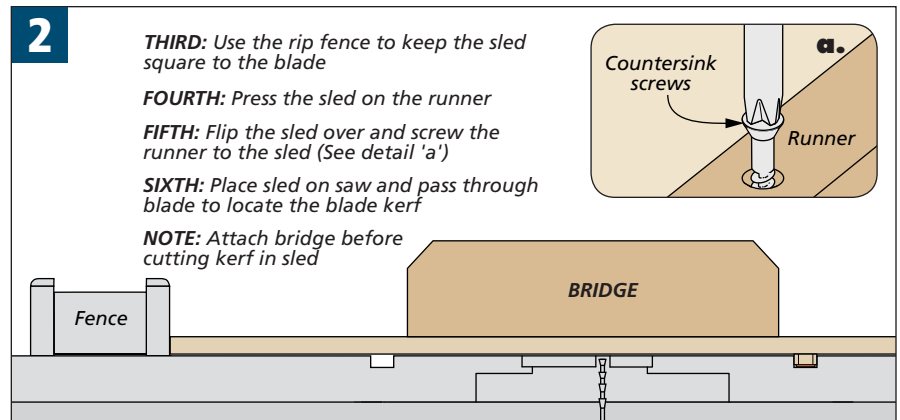
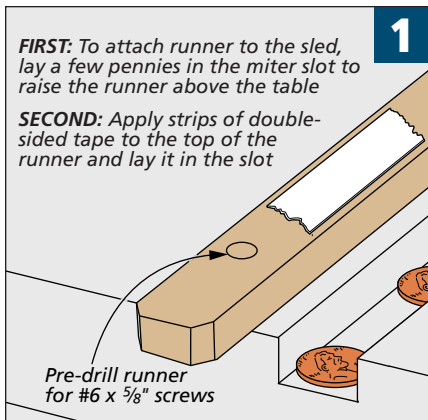

zero-clearance support to the bottom face and back edge of the workpiece, reducing the possibility of tearout.

Clearly, a sled makes a lot of sense. But what kind of sled should you build? I'd like to share two designs that meet most of my project-building needs, as shown in the drawings on the previous page. Think of these sleds as "everyday sleds" designed for general crosscutting duties.

ONE-SIDED SLED. The first sled shown in the main photo on the previous page is made to work from one side of the saw blade. It's like an extended miter gauge with a base. What's nice about this sled is that it doesn't weigh much. This means I'm more likely to actually use it. The sled works great for accurately cutting parts that are 24" or shorter. The base will fully support panels up to 12" wide.

TWO-SIDED SLED. The other sled design is larger, which allows for cutting longer

workpieces, as shown in the photo below. The space between the front bridge and the fence allows you to crosscut 12"-wide panels, much like the one-sided sled. But the base of this sled straddles the blade. Extending the base to the opposite side of the blade supports the waste piece as it's cut away. The result is it can't fall and possibly cause a split or kick back at you.

The two parts of the base are held together with hardwood bridges. The rear bridge piece incorporates a safety feature — a blade cover. This hardwood strip acts as a barrier to keep your thumbs out of the path of the blade as you complete a cut, as shown in the inset photo below. I made the fence out of a separate piece of hardwood from the bridge so that it's easy to fine-tune its position for a square cut.

SLED DETAILS. Both of the sleds are made from 1/2" Baltic birch plywood and 3/4"-thick hardwood. The runners are made

from hardwood and sized for a smooth-sliding fit in the miter track.

I only used one runner in the two-sided sled. Using two runners can be problematic. Unless they're perfectly parallel, the sled will bind in use.

You'll notice that the sleds operate from the left side of the table saw (as you face it). You could also set up the sled to work from the right side. But if the table saw is positioned with the right side against a wall, the wall limits the length of a workpiece that can be cut. With the sled on the left, the size of the workpiece isn't as restricted.

The fence on each sled has a small dust relief rabbet cut on the lower edge (detail 'b' on the previous page). And I added a strip of adhesive-backed sandpaper (180-grit) to the fence to prevent a workpiece creeping during a cut.

SETTING UP. A sled doesn't do you any good if you can't make square cuts. So accurate setup is an important element of building each sled. The drawings above show how I attach the runner so that it's parallel with the base.

After attaching the runner, I raise the saw blade and make a cut to establish the edge of the base. With this edge (or kerf) as a reference, use a square to attach the fence with screws set in oversized, countersunk holes in the base, as shown in detail 'a' on the previous page. Now take some time to make some test cuts and check the angle with a square. The oversize screw holes allow you to dial in the fence position for perfect cuts.



Two-Sided. A two-sided sled supports long boards and panels for making accurate cuts. The sled is guided by a single hardwood runner. On the back of the rear bridge, a blade cover provides a physical barrier to keep your hands clear of the blade (inset photo).



Repeatable Cuts. A hardwood stop block and a clamp are all you need to cut multiple parts to the same length. A lip on the top edge keeps the stop block square to the sled's base.



Purchased Stop. This swing stop from Kreg Tool slides in a T-track mounted to the fence. A cursor in the stop lets you dial in the setting using a tape measure attached to the track.

SLED UPGRADES

A basic crosscut sled makes getting precise, square cuts a sure thing. However, you can get even more out of the sled with a few accessories.

SIMPLE STOP BLOCK. The upper left photo shows a basic hardwood stop block that I routinely use. But this block has a few tricks up its sleeve. The lower corners of the block are chamfered. This creates a relief space for dust so it can't build up between the workpiece and the stop and spoil the accuracy of the cut.

Less noticeable is a wide, shallow rabbet on the back. The lip formed by the rabbet registers the block on the top edge

of the fence. It functions to keep the stop block square to the base.

A clamp-on block has a couple drawbacks. First, you need to get out a tape measure every time you set it up. And with the block clamped in place, you can't make other cuts without removing it.

TRACK & STOP. The answer to these drawbacks is to turn to a commercial T-track system. One of my favorites is shown in the upper right photo. A track is mounted to the top of the fence. It's designed to accept an adhesive-backed tape measure and a swing stop. You can flip the stop out of the way to make other cuts without losing your setting.

MAINTAINING A SLED. Over time, blade deflection and vibration may lead to the base of the sled getting a little chewed up to the point that it doesn't provide the same level of support and backup that it used to. But don't worry, you can quickly and easily refresh the sled and get tearout-free cuts without having to make a new one. The box below has all the details for each sled design.

A nice crosscut sled provides a higher level of accuracy and safety. More than that, it allows you to focus on the finer points of building projects and increasing your enjoyment of the process. That's a win-win in my book. **W**

Quick Fix: Zero-Clearance Tune-Up



Edging. With a single-sided sled, smooth the edge and glue on a strip of hardwood. After sanding the hardwood flush with the surface, make a cut, and the sled will work just like new.



Sub-Top. Bring a two-sided sled back into shape by cutting a piece of $\frac{1}{8}$ " or $\frac{3}{16}$ " hardboard to fit between the front bridge and the fence. Secure it with a few strips of double-sided tape.

Special-Purpose Sleds: Dado & Miter Sleds

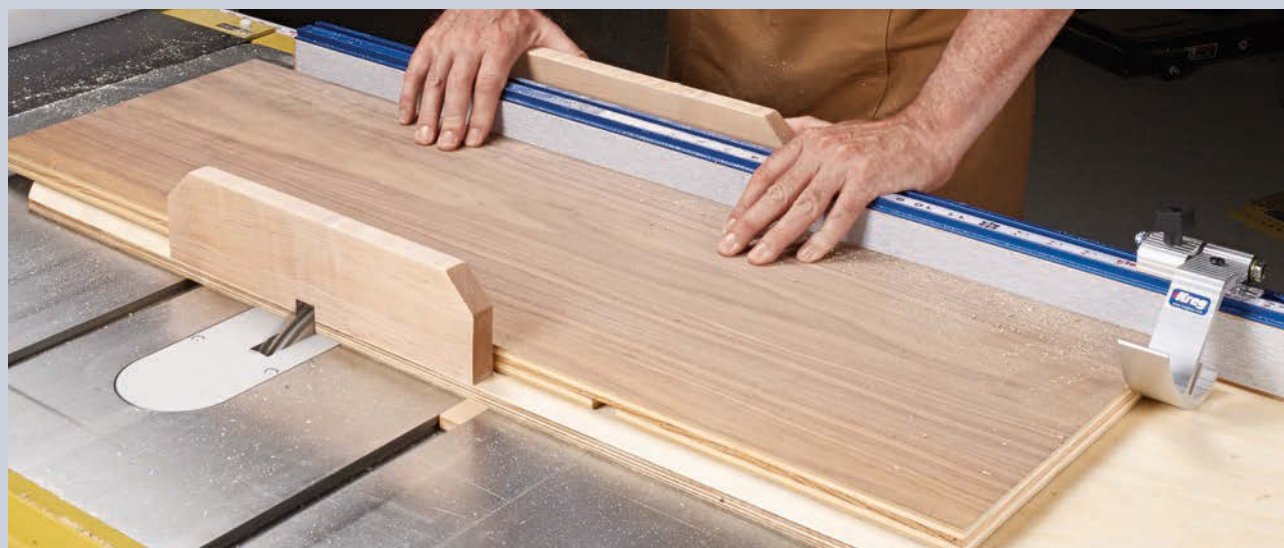

After working with a crosscut sled for a while, I started thinking of other table saw tasks that could be improved with a sled to guide the workpiece. The two ideas shown here are based on relatively common tasks. The idea behind each one is to simplify the setup.

DADO SLED

A lot of my projects are made from plywood pieces joined with dados. Long, narrow panels can be a challenge to guide when using either the miter gauge or the rip fence. To improve workpiece control, I made a version of the two-sided

sled and dedicated it for use with a $\frac{3}{4}$ " dado blade. Of course, you can use the sled with other dado width setups, but you won't have complete support right around the blade unless you add an auxiliary, hardboard base, as shown in the box on the previous page.

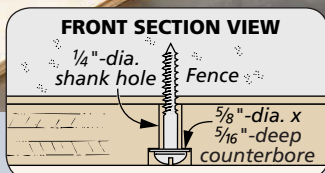

NOTE: Sled base is $\frac{1}{2}$ " plywood. Bridge is made from two layers of $\frac{1}{2}$ " plywood. All other parts are $\frac{3}{4}$ "-thick hardwood

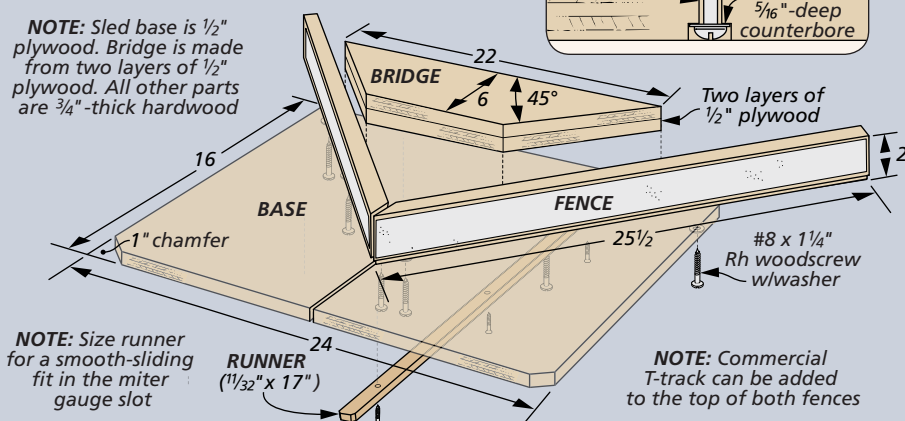

NOTE: Size runner for a smooth-sliding fit in the miter gauge slot

NOTE: Commercial T-track can be added to the top of both fences

MITER SLED

Cutting miters for a frame or to wrap molding around a project are a couple of other tasks where a sled can come in handy. Instead of resetting the miter gauge each time you need to make a cut, the sled you see here is automatically set for perfect 45° cuts.

While the look of this sled seems unique, it shares some of the same components as the one-sided sled shown on page 8. The base is the same size. The difference is that I positioned the runner to center the sled on the blade.

The miter sled incorporates two fences (with T-track) mounted at 45° to the blade kerf for left and right hand miter cuts. To hold the sled together and act as a blade cover, I made a trapezoid-shaped bridge from two layers of plywood. It's glued along the back edge of the sled. A small gap ($\frac{1}{4}$ ") between the plate and fences allows you to fine-tune the fence positions to dial in a perfect miter.

Table Saw Infeed Table

Using my table saw to break down large sheets of plywood into more manageable pieces is a key task. My saw has plenty of outfeed support, but large, thin sheets of plywood tend to sag from their own weight as they are being fed into the blade. This makes the operation a challenge.

To make this operation safer, I designed this infeed table. The table is easy to attach to my saw's fence rail when I need to cut a sheet of plywood. When I'm done, it folds up and stores out of the way (photo below). Its narrow profile allows me to walk alongside as I feed material through the blade.

MAKE THE TABLE. As shown below, the infeed table is constructed from plywood with a continuous hinge connecting it to the leg. The edge of the table is notched to fit around the rip fence and a long piece of aluminum angle is fastened to the tabletop to align with the fence.

A couple short pieces of aluminum angle screwed to the underside of the table slip over the front rail of the saw.



Two toggle clamps lock the table in place (detail 'a' below).

LEG. The leg is constructed from two layers of plywood glued together. To remove excess weight, I cut an opening in the center. A couple of T-nuts in the bottom of the leg assembly hold a pair of leg levelers. Two rare-earth magnets keep the assembly folded when stored.

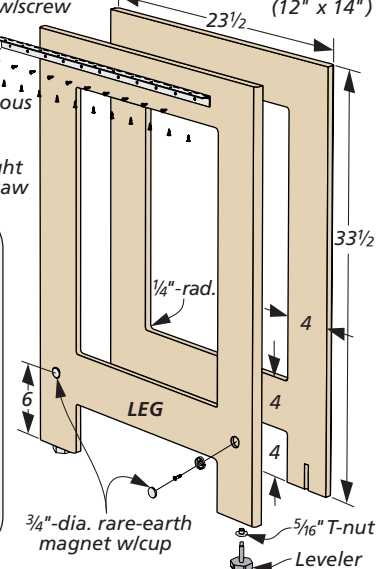
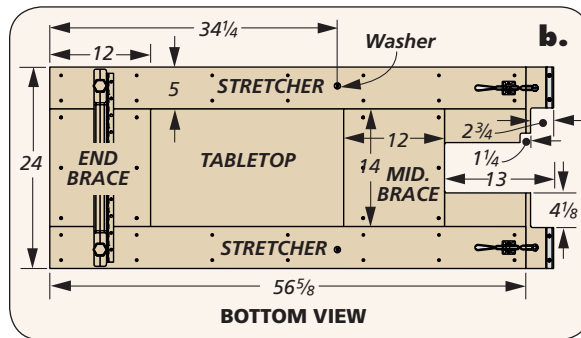
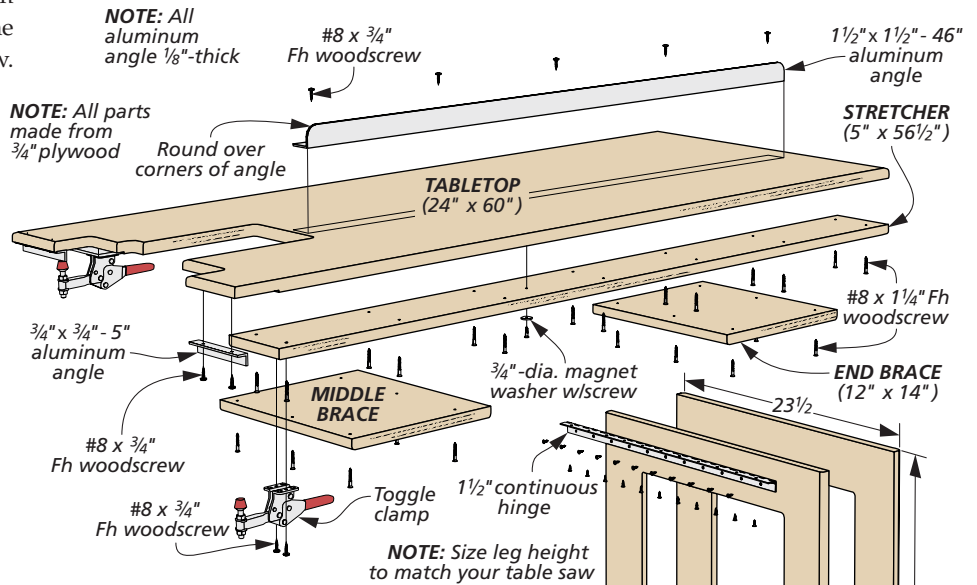
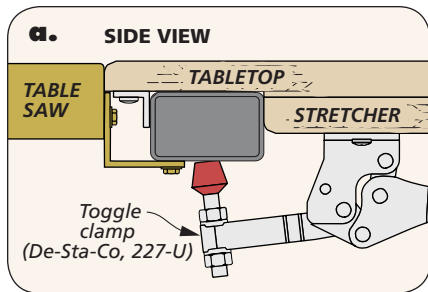

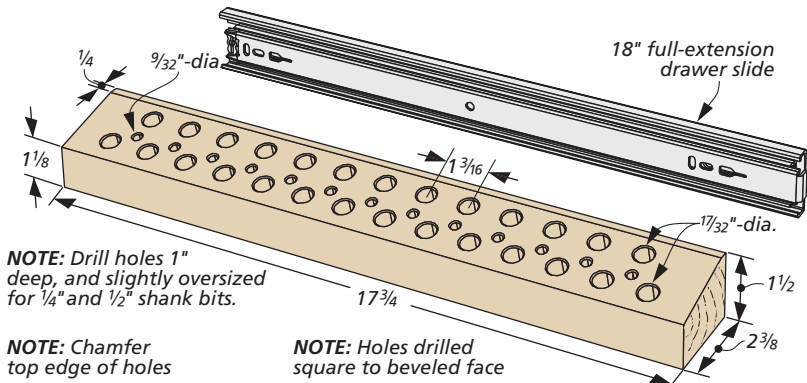

Out-of-the-Way Router Bits

I recently made a router bit storage rack from a solid-wood blank and mounted it to the outside of my router table's base. However, in my small, cramped shop, I was constantly snagging my pant leg or shop apron on the rack as I walked past. I wanted to keep my storage rack accessible, but out of the way. The solution to my problem came to me on a recent trip to the hardware store.

DRAWER SLIDE. Instead of installing the router bit storage rack to the outside of my router table base, I mounted the rack to a full-extension drawer slide. I then installed the whole assembly underneath my router table as shown at right. Now, to access my router bits, it's as simple as sliding the rack out and selecting the bit I need.

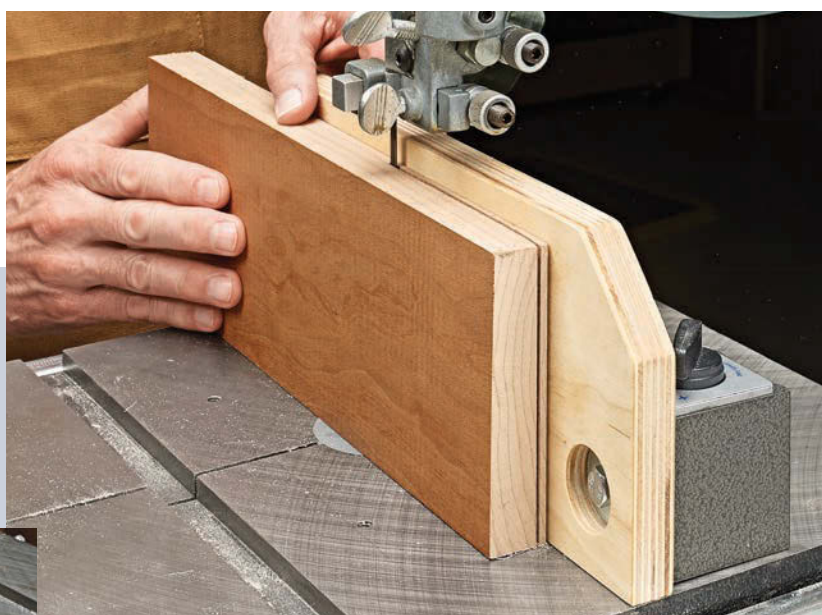

Simple Band Saw Fence

Recently, I needed to resaw some boards on my band saw to make bookmatched door panels. Unfortunately, the stock fence that came with my band saw was too short and too cumbersome to adjust to work effectively. I wanted something that could be adjusted quickly, but I didn't want to invest the money in a dedicated resaw fence.

Since I already had a couple switchable magnets (magnetic holder beds) on hand, I devised this fence system that meets all of my needs. It's tall enough to accommodate the stock that I typically resaw. And with the magnets acting as anchors, it couldn't be simpler to adjust.

Fence Construction. The fence is made from a piece of plywood with two counterbored holes at either end to attach the magnets. Most switchable magnets have a threaded hole in one face for this purpose. I also clipped the top corners of the fence to remove the sharp edges. To use the fence, simply set it in place on the band saw table and turn each of the magnets to the "on" position.

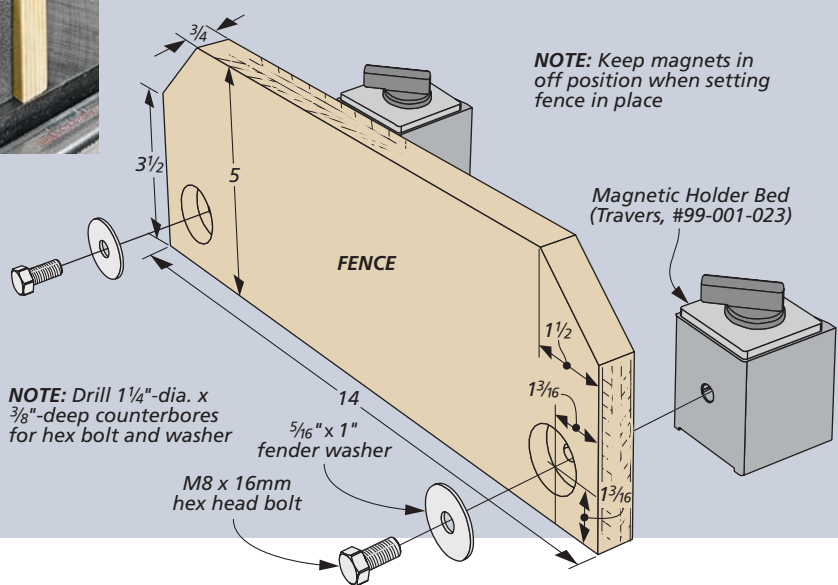

Biscuit Joiner Spline Slots

It's always important to look for new and creative ways to get the most from your woodworking tools. Recently while building several small boxes with decorative splines in the corners, it occurred to me that my biscuit joiner would do an excellent job of making the spline slots. All it needed was this simple-to-build jig that attaches to the fence on the joiner.

MAKING THE JIG. The biscuit joiner jig is easy to make from a piece of plywood. Start by cutting the vertical V-groove centered on the front face of the plywood workpiece. I did this at the table saw with the blade tilted to 45°. A couple of passes completes both sides of the groove. The important thing is that the V-groove opening ends up being 90°. This allows the jig to “wrap around” the corner of the workpiece.

Next up is a series of evenly spaced kerfs running horizontally across the face of the jig. These kerfs hold an acrylic (Plexiglas) index bar (illustration, below) that determines the location of the spline slots on the workpiece. In the case of my jig, the spline slots are 1" apart. I used 1/8"-thick acrylic so the kerfs can be made with a single pass across the table saw blade. The acrylic index bar should be a snug fit in the kerfs.

A vertical pencil line centered down the back face of the jig aids in aligning the jig to the joiner fence. The jig is positioned so the bottom kerf is 3/4" from the top of the joiner blade (top photo). This will locate the first spline slot 3/4" down from the top of the box. Attach the jig to the joiner fence with screws.

CUTTING SPLINE SLOTS. To cut a spline slot, put the acrylic index bar in the appropriate kerf (middle photo, right) and rest the index bar on the top of the box (bottom photo, right) with the corner seated in the V-groove. Now just plunge the cutter into the corner for a perfect spline slot.



NOTE: Jig made from 3/4" plywood

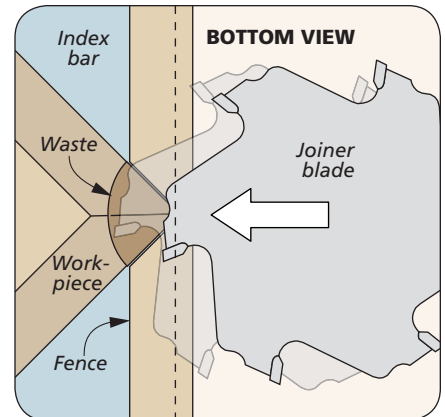
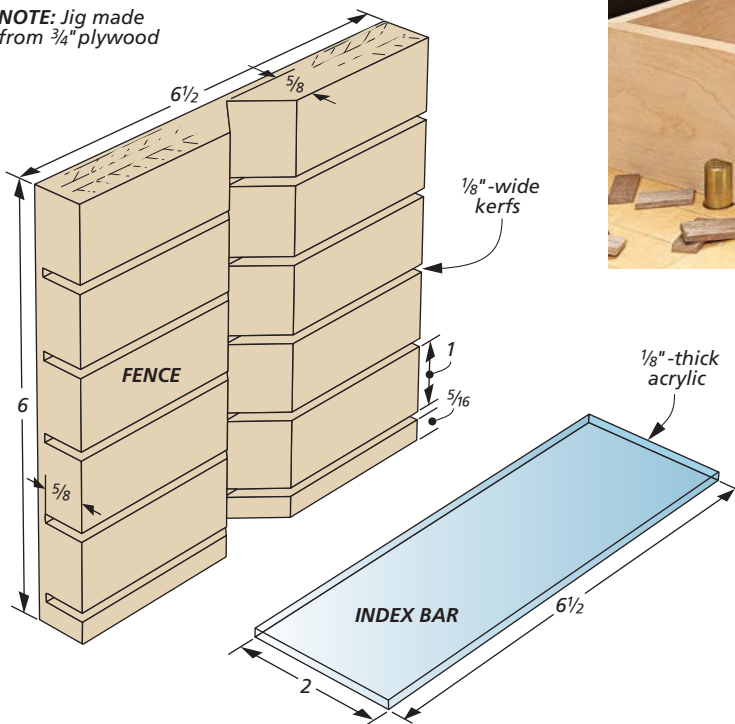



Zero-Clearance Insert Spacer

I make my own zero-clearance inserts, but my saw blade can't be lowered enough to cut the blade slot in the insert blank with the insert in place. So I came up with this idea.

I made a spacer from hardboard sized to fit the saw opening. It has to be just thick enough to clear the blade's teeth when the insert blank is set in the opening (Figure 1). Cut an oversize slot for the blade with a jig saw and it's ready to use.

To cut the blade slot in a new zero-clearance insert blank, I lower the blade and place the spacer in the opening. Put a blank insert on top and clamp it down (Figure 2). Turn on the saw and slowly raise the blade until it cuts through the blank.

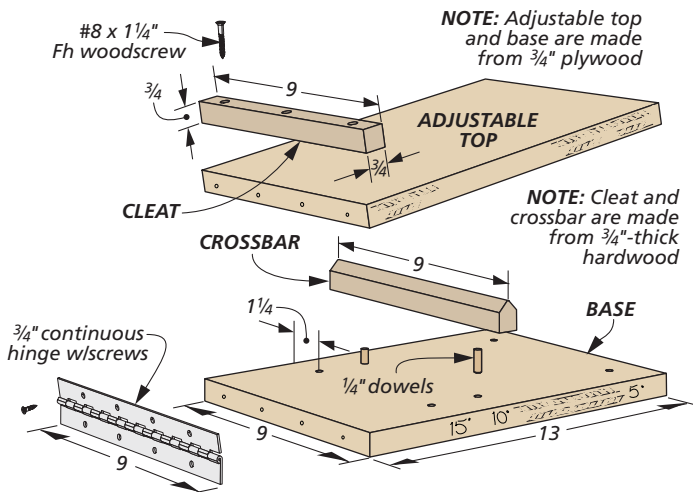
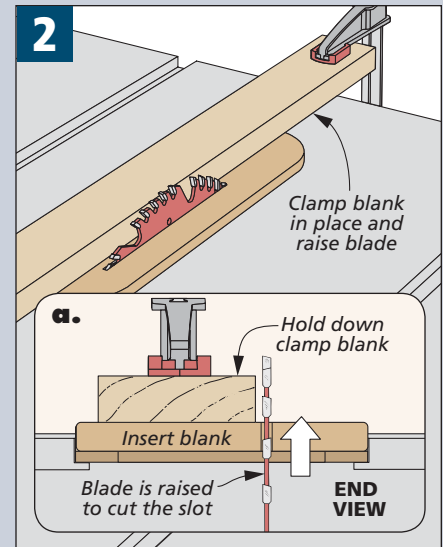
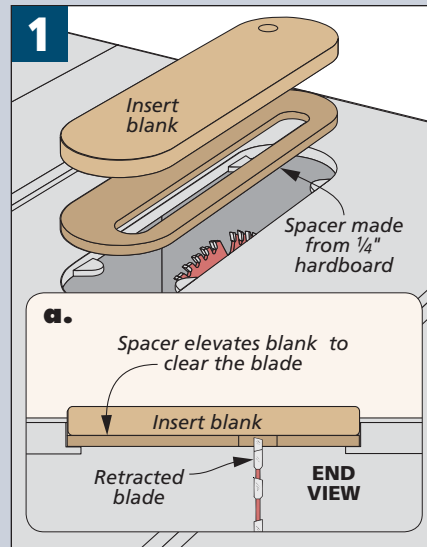

Drill Press Angle Support

When drilling angled holes, I used to just prop up the workpiece with scrap wood on the drill press table and eyeball the angle until it looked right. Then I was building a complicated coat rack with multiple pegs, and I realized I had a problem.

To improve the accuracy and consistency of my holes, I made this adjustable angle support. The two pieces are hinged together and held at a fixed angle by a crossbar. The crossbar has dowels on the underside that fit in holes in the base (illustration at left). The support can be designed for a single angle, but I made mine adjustable for the most common angles I drill: 5°, 10°, and 15°.

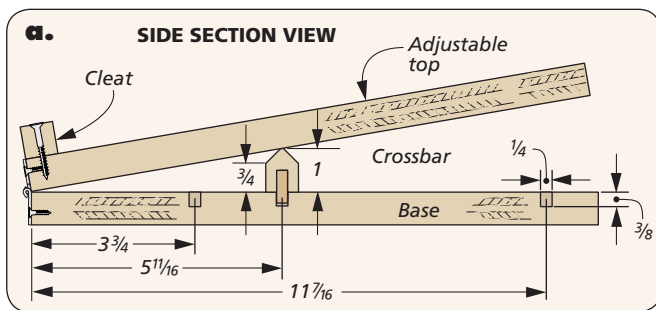

Quick Tip



PENCIL LUBRICANT

I seldom have a can of dry lubricant handy. But I always have a pencil in my apron pocket. If I notice the miter gauge in my table saw sticking a little, I blow out the sawdust and scribble on the sides and bottom of the miter gauge slot. The graphite keeps things sliding freely.

NOTE: Schedule 40 PVC used for all parts

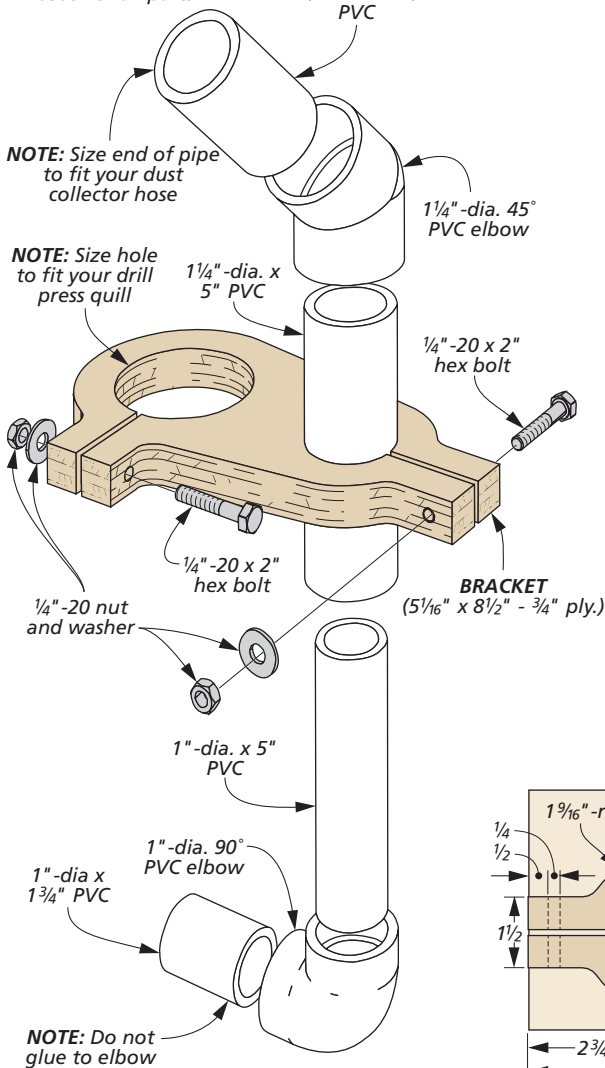

Drill Press Dust Collection

Managing chips and sawdust when using the drill press is always a challenge. The problem is where to locate the vacuum hose for maximum effectiveness.

The solution I came up with is the attachment you see above. It consists of a bracket and telescoping pipe assembly that attaches to the quill of your drill press.

of the telescoping PVC pipe. A pipe with a smaller diameter slips inside the fixed pipe. This allows it to move up and down with the drill press quill, always keeping the suction near the drill bit. An elbow on the end directs the suction toward the bit.

I used 1 1/4-inch diameter pipe for the fixed portion of the assembly. A 45-degree elbow fitting at the top is used for attaching the hose from my shop vacuum. You may need to sand the outside diameter to fit your vacuum's hose.

The internal, sliding portion of the pipe assembly is made from 1-inch diameter pipe. A 90-degree elbow and short length of pipe allow it to reach near the drill bit. I didn't glue this in place in case I need to remove it for additional clearance.

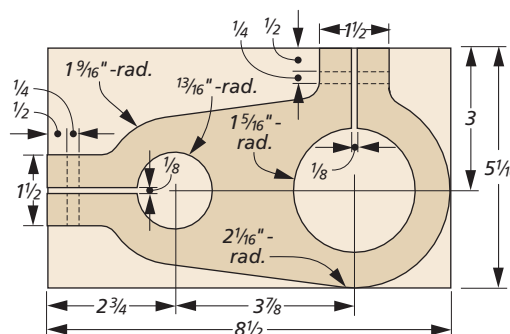

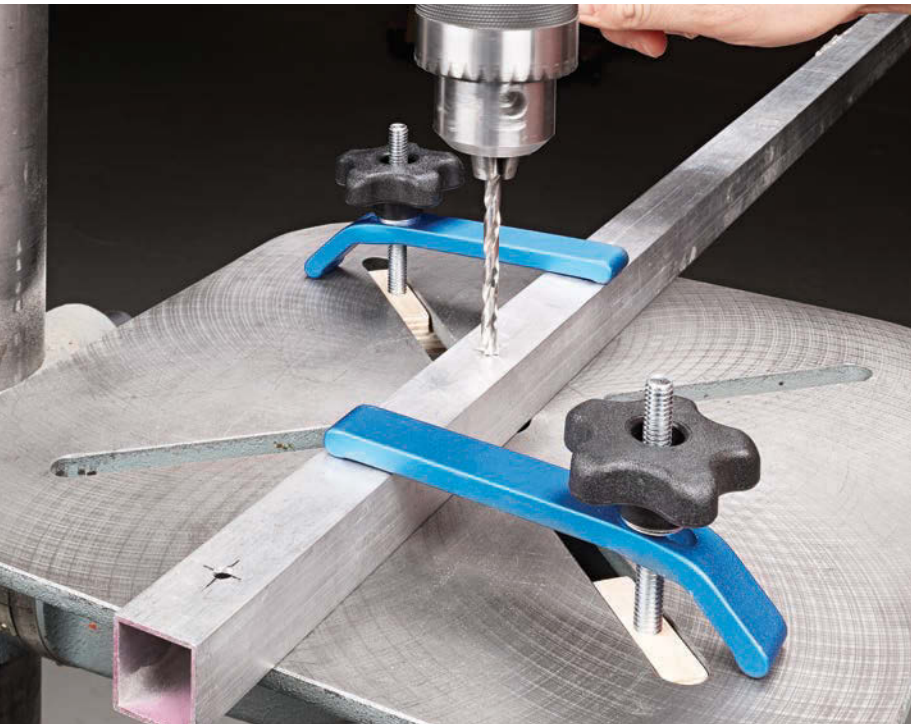

Custom Fit. These shop-made hold-downs are custom fit to the slots of your drill press table. Two of these clamps will cover all your needs.

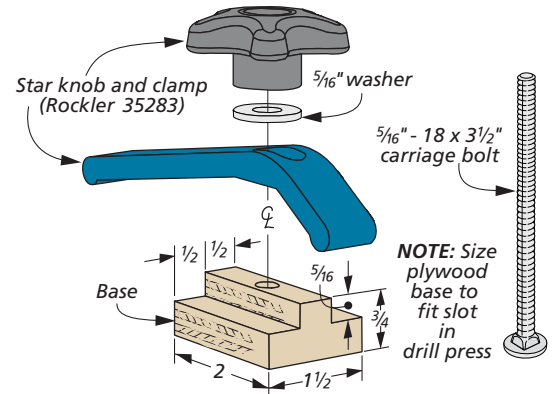

Handy Drill Press **Hold-Downs**

I found myself facing a project that required drilling a lot of holes in square metal tubes. Drilling metal of any kind at the drill press can be a grabby and unsettling affair. Once the bit breaks through the metal, the flutes of the drill bit often dig into it instead of shearing away the material. Then the metal bar wants to

abruptly lift off the table and climb up the bit. This is not only annoying, it can also be somewhat dangerous.

GETTING A GRIP. To bring some calm to the situation, I made a couple of hold-downs that can be used in any of the four slots in the bed of the drill press. Each one starts with a plywood, 'T'-shaped base that fits into the opening

of the slots in the drill press from underneath. A carriage bolt passes through the plywood, the hold-down clamp, a washer, and then into a star knob to bring the clamp together. This unit slides anywhere along the bed of the drill press. With the long arm and pivot ability of the hold-down clamp, you're completely covered.

Quick Tips



TRUE GRIT

I find it easy to forget what grit of paper is on my random-orbit sander when it's stored between uses. Writing the grit number on the center of the face leaves all the information needed when starting my next sanding project.



EASY ZERO-CLEARANCE TABLE

While cutting small pieces at the band saw I found that cutoffs often got stuck in the throat of the insert. So I cut a kerf in a piece of plastic laminate to form a zero-clearance table. Double-sided tape holds the table in place.

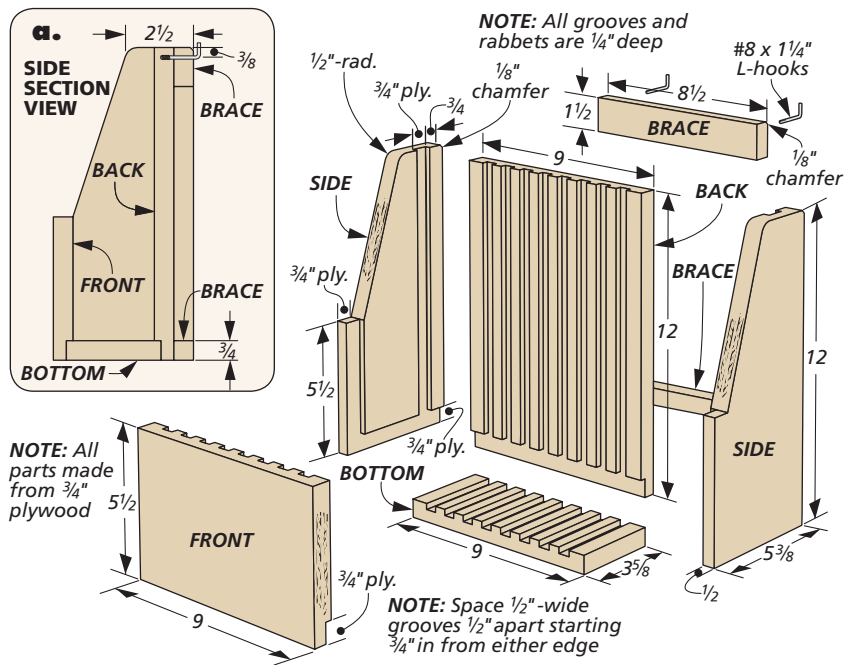

Table Saw **Insert Caddy**

Whenever I get a new blade for my table saw, I generally make (or buy) a new table saw insert so that I have a zero-clearance insert to match each blade. As you might imagine, I have accumulated quite the collection of table saw

inserts over the years. In order to better organize the inserts, I made the handy caddy you see above.

PLYWOOD PROJECT. The front, bottom, and back have aligning grooves. I cut all of the grooves in one oversized piece and

then cut the three parts to size. Cut $\frac{3}{4}$ "-wide rabbets in the front, sides, and back before assembling the caddy with glue. To create clearance for installing the caddy on a pegboard panel, I chamfered the upper back edges.

Bit Bearing **Changing Jig**

After scoring the router bit shaft with a vise on one occasion and cutting my finger on another, I came up with this jig to safely hold the router bit while loosening the bearing screw.

I cut a block of wood to the size shown in the drawing below. Drill holes for the bit shaft, dowel pin, and the plunger mechanism. The dowel pin on the opposite end provides additional support for larger, profile bits.

The jig can be held in your hand or placed in a vise. To use it, retract the plunger, insert the bit in the hole and release the plunger to grip the cutters while you loosen the screw.

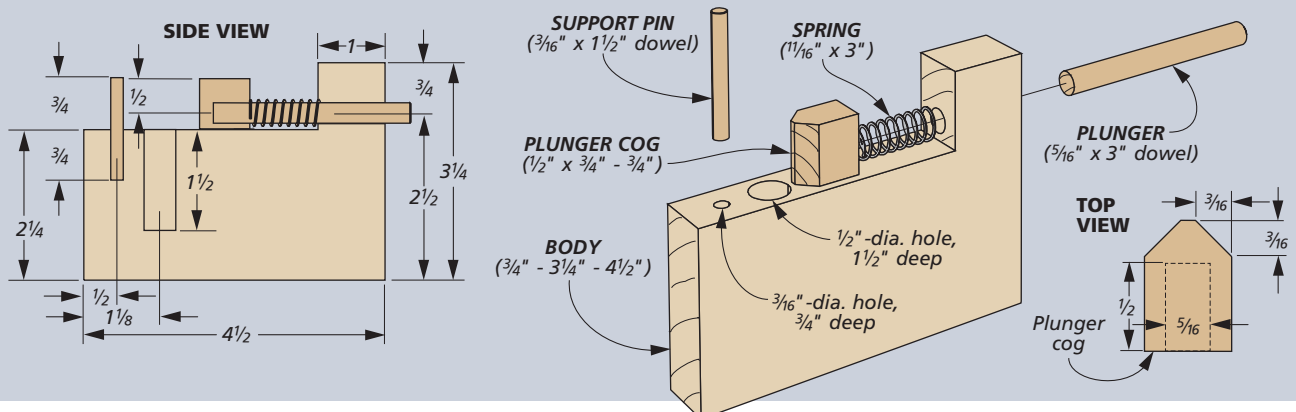

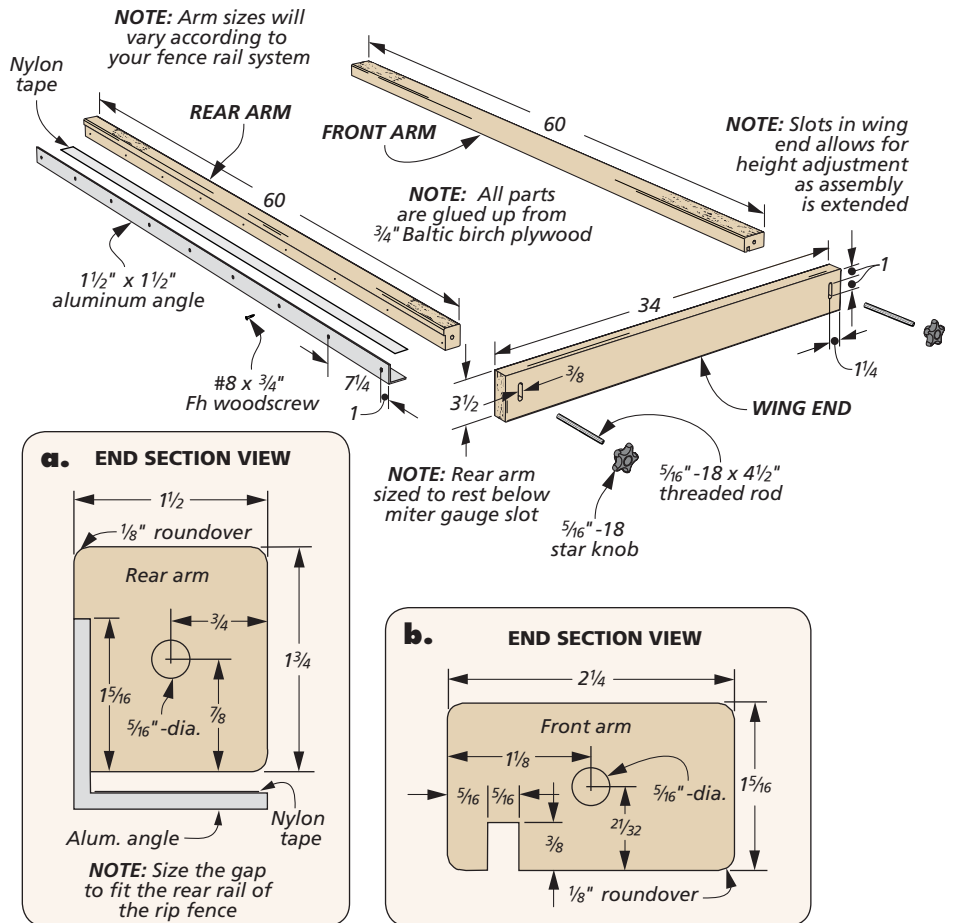

Table Saw Side Support

I love the mobility and power of my contractor's saw. I wouldn't trade it for the world. But the setup does have some shortcomings, mainly when working with long boards or plywood. There's just not enough support for my liking when making these cuts.

WING MAN. To improve on this, I built a sliding wing that attaches to the guide rails of my table saw. The whole system is made of plywood. The front arm glides in and out of the attached front tube, while the rear arm combined with a piece of aluminum angle straddles the rear rail. The two arms are tied together with the plywood wing end.

DETAILS. The aluminum angle that's attached to the rear arm has a strip of nylon tape for smooth operation (detail 'a'). The front arm has a groove in the bottom to allow clearance for the fence bolts (detail 'b'). Both arms have a threaded rod epoxied into the ends to attach them to the wing end with knobs. The plywood wing end is slotted to allow for adjustments in height as the wing extends (inset photo).





Router Table Fence Micro-Adjuster

I needed a simple, but effective, way to finely adjust my router fence and still be able to return it to its original position. This fixture gives me the precise fence adjustment that I need.

BODY. The wood parts for the body and fence block are small. So to safely cut these, start with oversize blanks. I laid out and cut the notches and rabbets, and then drilled the holes for the

threaded inserts and bushings. Then I cut the parts to final size. (You may need to adjust the dimensions and hole locations to suit your fence and table.)

ADJUSTMENT MECHANISM. I cut out the adjustment wheel with a hole saw and installed a threaded insert into the center after enlarging the hole. The wheel assembly is screwed onto the threaded rod which is inserted through two nylon bushings

in the body. Another threaded insert is used for the stop bolt and a jam nut locks it in place (top view).

TABLE CLAMP. The body is clamped to the table with a flange bolt and a star knob. If your table doesn't have a slot or a T-track for the fence, a simple C-clamp will hold the adjuster in place.

FENCE BLOCK. The fence block may also have to be modified to suit your particular

fence. It should be located so the hole for the threaded rod lines up with the hole in the body. Two lock nuts are tightened against the block so the rod doesn't spin. It can be attached to the fence with machine screws and wing nuts or just screwed in place as shown in the photo and drawing.

To use the micro-adjuster, roughly position the fence and tighten the knob to lock the body. Turn the adjustment wheel to precisely position the fence as needed. The stop bolt allows you to return the fence to its original, starting position, if that becomes necessary later.

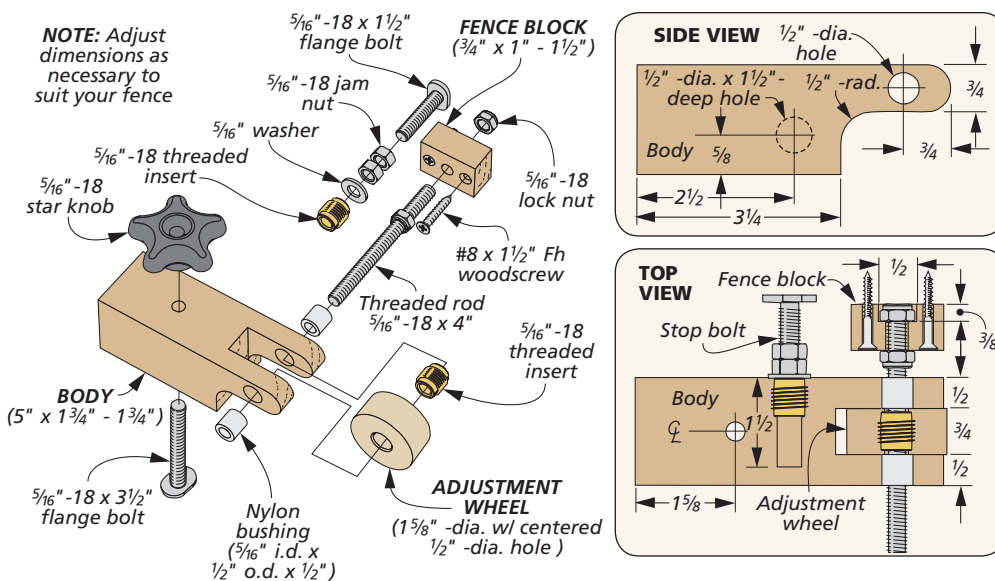



Random-Orbit Sander Cradle

I frequently need to sand small parts for projects. Since I don't own a stationary belt or disc sander, I'll turn to my random-orbit sander. However, holding the sander in one hand and a small workpiece in the other can be awkward. To make the process safer, I made this plywood cradle that holds my random-orbit sander upside down. This allows me to bring the workpiece to the sander instead of the other way around.

VENTED BOX. The nice thing about this cradle is that it's easy to customize to fit almost any sander. In my case, one end is notched to make room for the power cord and the dust collection port. The other end has a hole that allows easy access to the power switch. And a few holes drilled along each side of the cradle provide ventilation to the motor. One side is taller than the other to secure the cradle in a vise.

Access Hole. A strategically placed hole in the front end of the random-orbit sander holder provides easy access to the power switch.

Quick Tip



WORKBENCH POWER

I was having problems with the power strip on my workbench always getting knocked around while working on projects. I found the perfect solution while putting up the Christmas lights: An outdoor power bank with a stake that just happened to fit perfectly into the dog holes of my workbench.

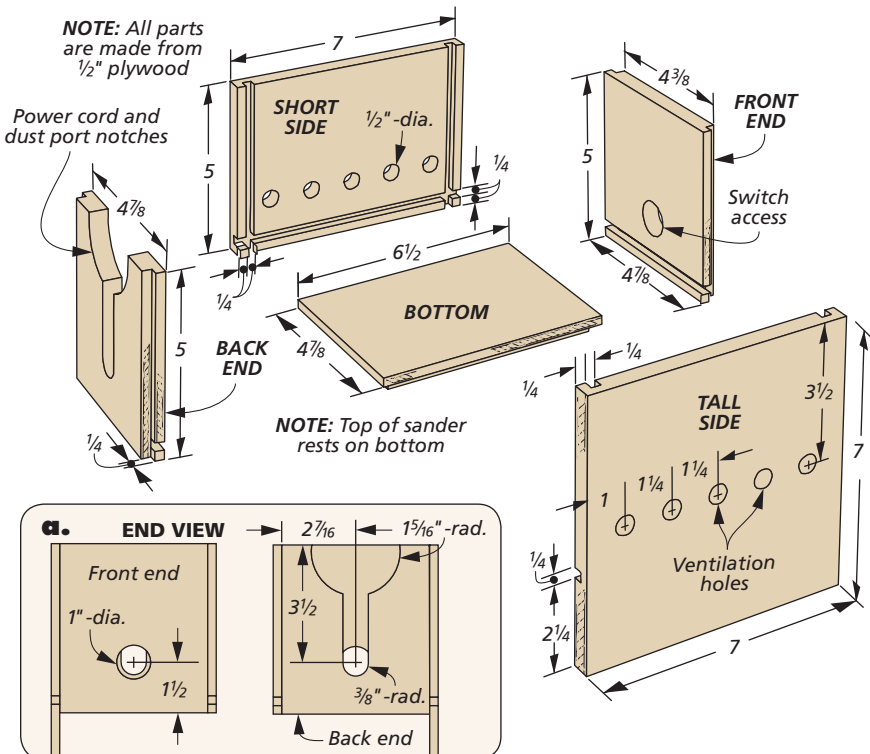



hand-held router

Tips & Tricks

It only requires a few simple strategies to ensure that you get great profiles and smooth results when using your hand-held router — each and every time.

Few woodworking tools are as versatile as the router. Whether you use it for cutting rabbets (above), making frame and panel doors, or adding profiles to parts, a router can handle almost any task you give it.

But when you're just getting started, using a router isn't exactly intuitive. There are no gauges, scales, or fences on most routers. That's why some sound advice before setting up and using a hand-held router is often a good idea.



One Hand. It's possible to over-tighten a router bit in the collet. By using one hand to tighten, you can avoid over-tightening, as well as pinched fingers.

SECURING ROUTER BITS. On its own, a router isn't going to do much. You need to outfit the router with a bit to do the cutting. And even this requires a few basic steps in order to do it right.

To secure the bit in the router, you'll slide the bit's shank into a chuck known as a collet and tighten the collet nut (drawing at left). But you don't want to just stick the bit in as far as it will go and tighten the nut. That's because most router bits have a rounded portion at the top of the shank called a "fillet." If you were

to tighten the collet on this fillet, it wouldn't get a firm grip on the shank, and the bit could slip in use.

To prevent this, you'll need to insert the bit all the way, and pull it back out

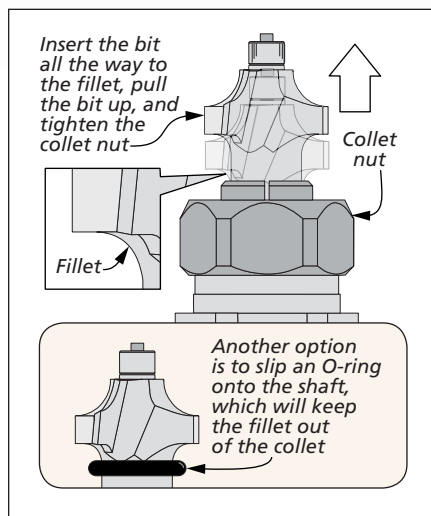

past the fillet before tightening the nut. Another option, shown in the drawing at left, is to slip a rubber O-ring around the shank of the bit. This prevents the shank from seating too deeply in the collet.

Tightening the collet nut is done with either two wrenches or one wrench and a spindle lock, depending on your router model. You can actually over-tighten the collet if you're not careful, so a good rule of thumb is to tighten it by hand, and then add another one-third turn. I like to finish up by squeezing the wrenches with one hand to avoid pinching my fingers (lower right photo, opposite page).

SET UP TO CUT. Once the router bit is secured, adjusting the cutting depth is the next order of business. This is usually a matter of adjusting the base until the bit emerges through the opening.

Before actually routing, I like to set the end of a steel rule on the router base and hold it up to the side of the bit. This way, I can make sure the router bit is set to match the depth of cut. Then I'll make a test cut in a scrap piece as a last check before I move along to the actual workpiece.

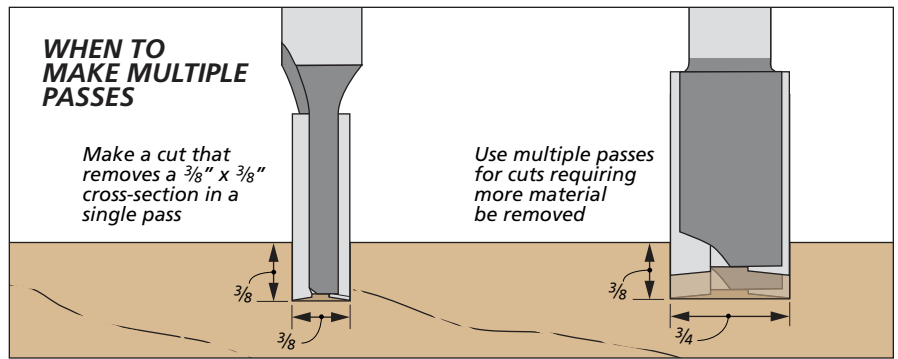
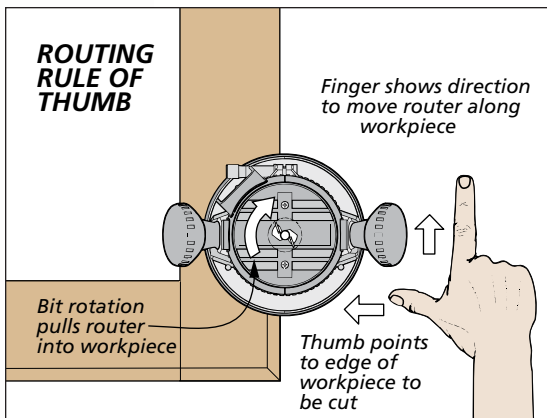

MULTIPLE PASSES. Sometimes, the profile of a cut made by a router is too large to be formed in just a single pass. In these instances, you'll need to reduce the size of the "bite" taken by the router bit and make the cut in a series of passes. The illustration above gives you a good guideline of how to handle these situations.

GO THE RIGHT DIRECTION. The first time you use a router, the direction that you are supposed to move the tool along the wood is not readily apparent. But moving the router in the wrong direction can cause it to grab the workpiece and even pull free from your hands. To prevent this, you want to move the router against the rotation of the bit. And there's an easy way to figure out which direction to rout.

To rout in the proper direction, just refer to the illustration at left. You simply hold your right hand over the router in a backward "L" shape. Point your thumb at the edge to be cut, and your index finger shows the direction to move the router.

The only other place where you can sometimes get mixed up is when you're routing the inside or outside edges of a frame. But here again, the right hand trick still applies (lower left illustration).

SECURE YOUR WORK. When routing with a hand-held router, the last order of business is to secure the workpiece so that you can rout safely. If you're making light passes, then a non-slip mat like the one shown in the main photo on the opposite page works great for keeping the workpiece in place.

Clamps or bench dogs can also hold pieces securely while routing, but you'll need to make a couple of extra considerations when using them. Clamps sometimes interfere with the path of the router, so I tend to reserve them for situations when I'm only routing one edge of a workpiece. Bench dogs are also effective, but you'll want to make sure the bit and bearing will safely pass over the top of them. For this reason, I tend to use them mainly for thick pieces (photo below).

READY TO ROUT. Few woodworking tools are more enjoyable to use than the router. Once you understand the basics of the tool, it opens up a wide world of woodworking possibilities. **W**

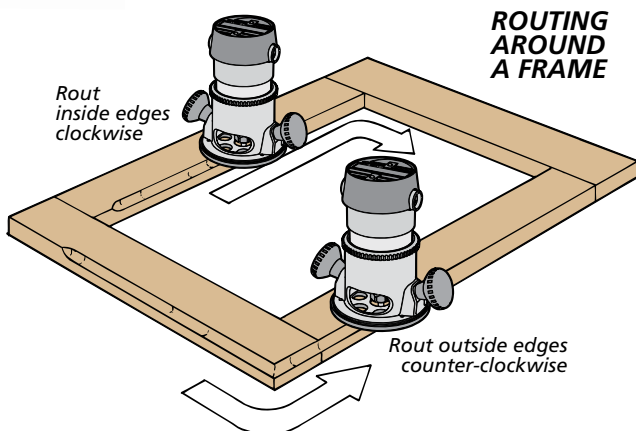

Solid Support. Bench dogs can be a useful workbench accessory when routing. Just make sure they rest safely below the path of the router bit and bearing before making a routing pass.





simple shop Solutions

A well-equipped shop makes your work more efficient and the time you spend working there more enjoyable. This collection of ideas, projects, and practical advice will help with your shop space.

SMALL SHOP IDEAS26

TIPS & TECHNIQUES.....28

CREATIVE CLAMP STORAGE42

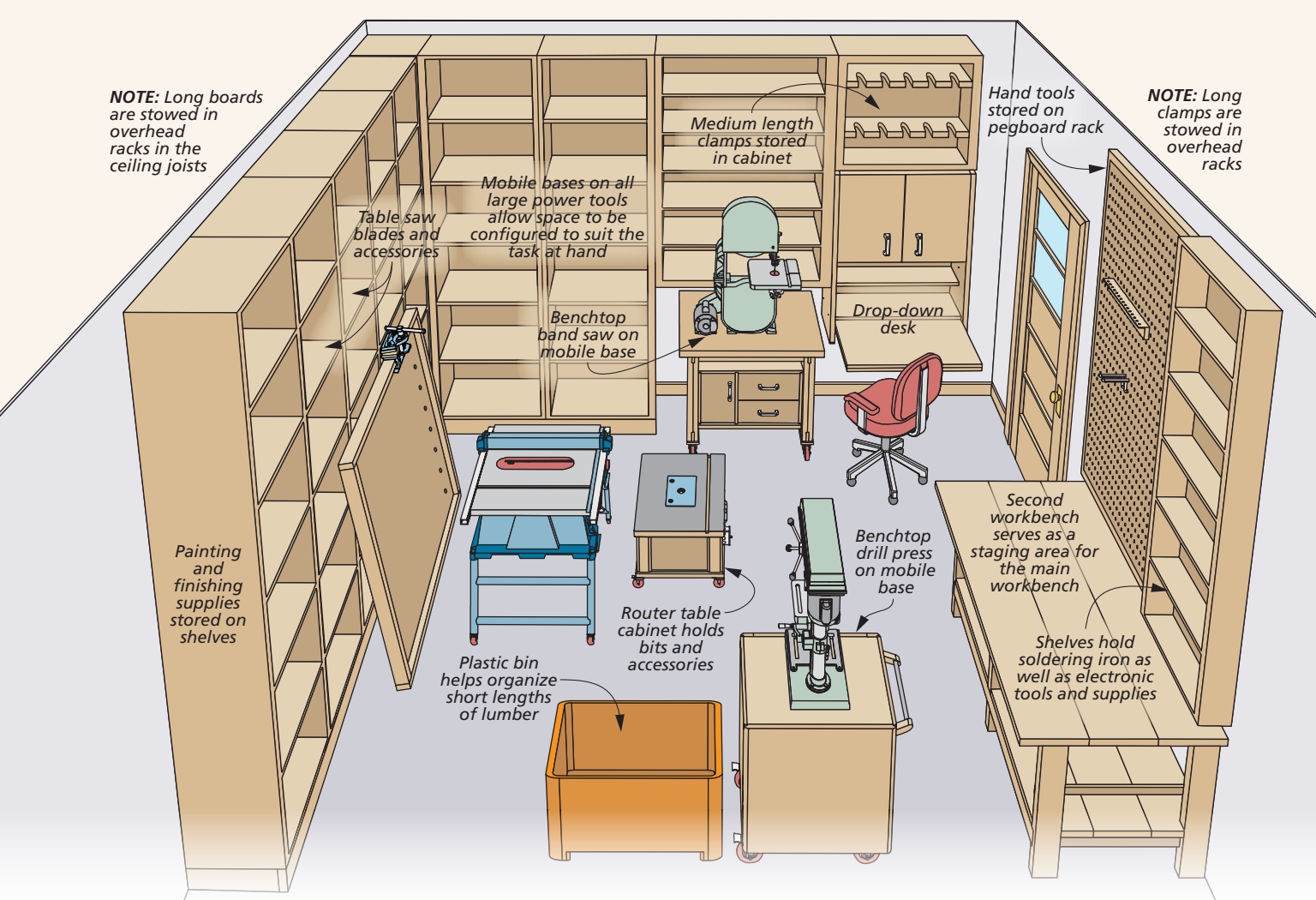

space-saving Small Shop Ideas

By making creative use of a small space, this compact basement workshop takes storage, functionality, and versatility to a whole new level.

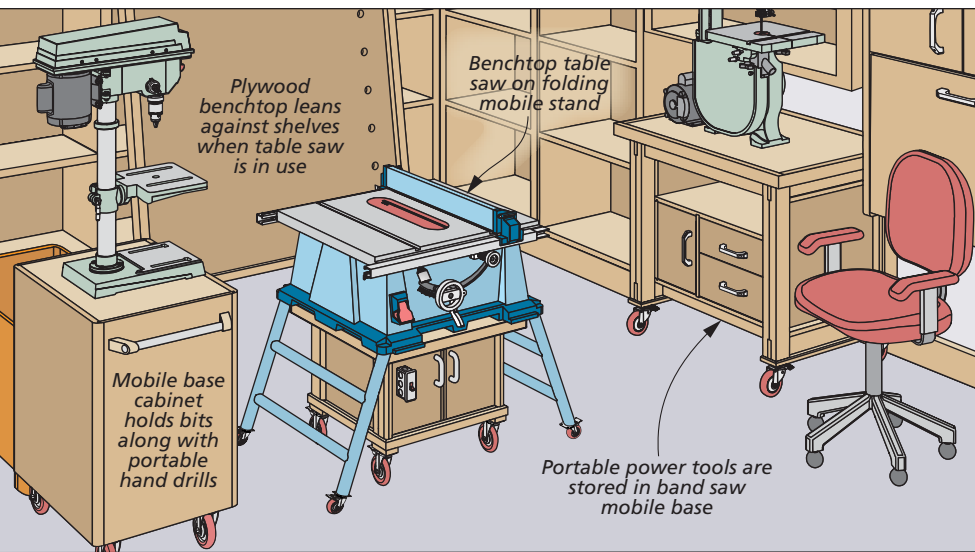

Most woodworkers will describe their workshop as small. And nearly every woodworker will tell you that they could use some more space. But one look at *Woodsmith* graphic designer Bob Zimmerman's workshop redefines what a hard-working shop is. I know it did for me.

COAL ROOM. Bob's house was built back when homes needed dedicated rooms to store coal to feed the furnace. In most houses, the old basement coal room became a storage space. For Bob, the 12' x 12' room was the only place where he could set up shop.

While there are many ways to make the most of a tiny shop space, they fall into two broad categories. One is a minimalist

approach that maximizes the open floor space. The other method finds clever ways to fit as many tools and supplies into the space available.

It's the second strategy that's on full display here. As the drawings on these pages show, just about every square inch of wall and floor space is taken up by storage, workbenches, or tools. At first glance, it may seem cramped. But talking with Bob, I soon saw how versatile and handy the space is.

MANY INTERESTS. In spite of the small space, some big-time projects have come out of this shop. As part of a kitchen remodel, Bob made a built-in booth with storage cabinets and a tall pantry cabinet. Large projects like these have taught him valuable lessons on planning and working with smaller sub-assemblies.

Besides woodworking, the shop serves as the repair station for furniture, toys, and other home maintenance jobs.

As if that weren't enough, Bob enjoys building and flying radio-controlled model airplanes and birds. So he keeps electronics tools and supplies in here, as well.

MULTIPURPOSE ISLAND. As you might expect, a table saw occupies center stage in

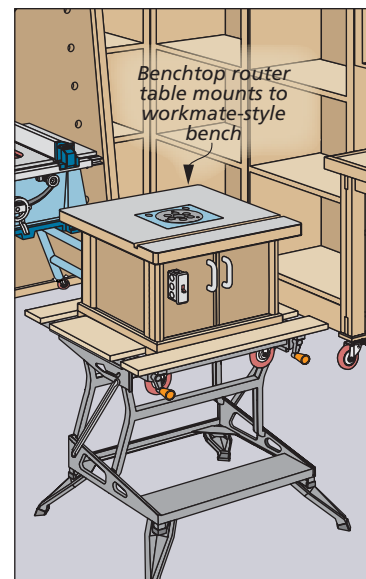
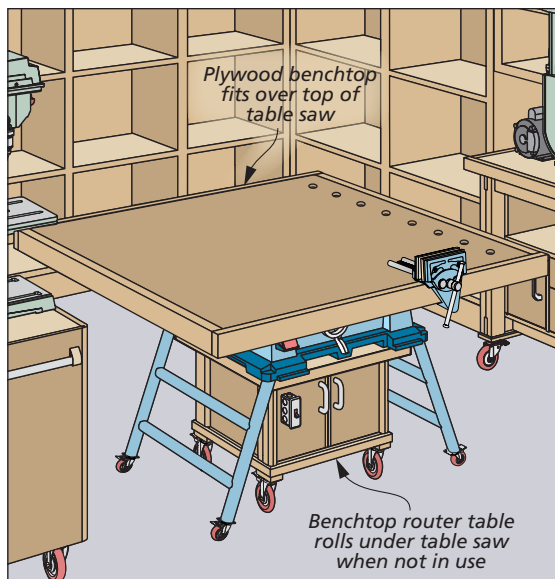

the shop. It's a portable, jobsite saw on a folding stand. The small size of the shop makes a portable saw a good choice. But another reason Bob chose it was that he can take it out of the shop for on-site tasks without too much effort.

Most of the time, the saw is topped with a large plywood cover and serves as the main workbench. A row of dog holes along the front provides plenty of options for securing a workpiece. In addition, there's a clamp-on vise

the removable benchtop for any workpieces that need to be secured.

There's more to this setup than a double-duty bench and saw combination. A benchtop router table tucks under the saw stand. Casters on the router table allow Bob to easily roll it out from under the saw. Then he sets it up on a folding, *Workmate*-style bench.

STORAGE GALORE. The walls surrounding the table saw are lined with shelves, cabinets, and pegboard panels. Altogether, they hold all his tools and supplies.

Here's where having a small space really pays off. Just about everything he might need while building a project is within arm's reach — or just a few steps away. Bob even managed to squeeze in a second workbench along one wall to serve as a staging area.

Many items are stored in toolboxes and canvas bags. These are used to organize tools around specific tasks (plumbing, electrical, gluing, etc). And just like the table saw, Bob can quickly and easily gather up what he needs for use outside the shop.

ROOM FOR EXTRAS. A small band saw and a benchtop drill press round out the larger power tools. These are on mobile bases so they can be stored out of the way when they aren't needed.

Woodworkers are a creative and resourceful group. And Bob's basement shop is proof that you can take just about any space and turn it into a place to enjoy your favorite hobby. **W**

TOP VIEW

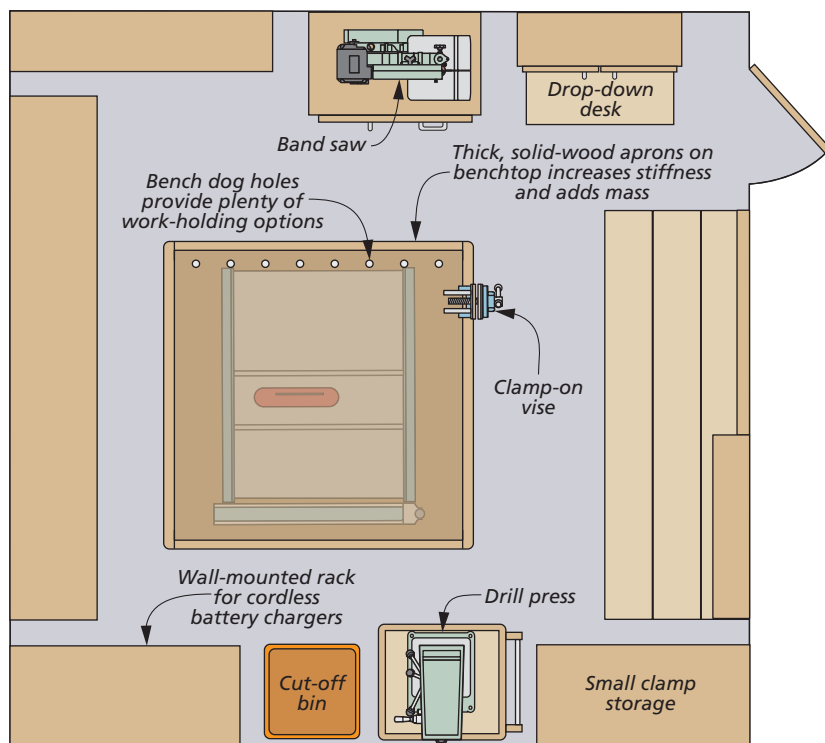

Small Parts Carousel

There's never a shortage of small parts and loose pieces of hardware cluttering my workbench. I needed a way to organize some of these items while still keeping them close at hand. My solution was to build this double-decker small parts carousel (photo at right). It's designed to hook into my pegboard, keeping my workbench tidy and ready to use.

CONVENIENT DESIGN. At the heart of the parts carousel are some 4" clear plastic jars with screw-on lids. These jars are available from *Lee Valley* and are the perfect size for organizing a vast array of small items. The holes in the upper and lower discs on the carousel are sized to allow the jars to slip into place easily.

SIMPLE TO BUILD. With the exception of the hardwood dowel and the PVC spacers, the carousel parts are all made from plywood. I made the top, bottom, and back first. A shallow hole in the top and bottom holds the dowel, and a couple rabbets are needed at the ends of the back.

Next, cut the two discs to size and lay out the six holes for the jars, as well as the center hole for the axle. To ensure all seven of the holes align, clamp the discs together. One hole in the upper disc is notched (detail 'a') to make removing jars from the lower disc easier.

Soften the edges of the discs with a roundover bit and assemble the carousel. Screw the bottom to the back first. Then it's just a matter of stacking the rest of the pieces in place, as shown at right, before screwing the top to the back. A couple L-hooks allow the rack to hang on a pegboard panel.

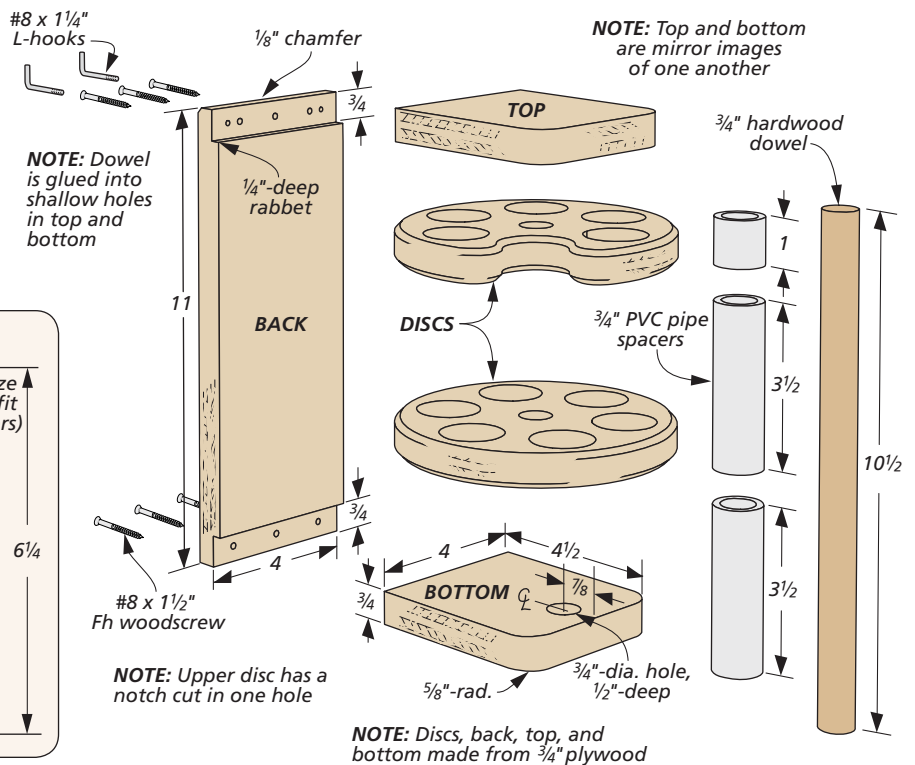
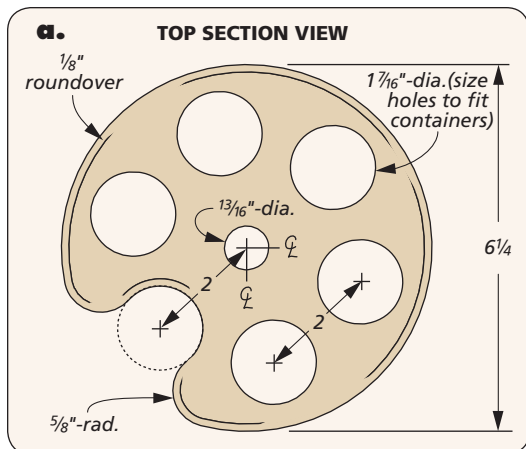



Roller Bars

When I work on bulky items like large drawers and cabinets, I like to be able to rotate the workpiece for easier access to all sides of the project. My solution was to build several of these “roller bars” using 360° roller bearings (*Rockler.com*, #20815).

These bars are easy to make by attaching the roller bearings to a piece of “two-by” stock. A cleat fastened to one end of the bar butts against the edge of the workbench and helps to keep the bars aligned.

For smaller projects, a piece of plywood or MDF can be laid across a few roller bars and used as a platform, as shown above. If sized properly, the roller bars can also serve as table saw outfeed rollers.



Easy Alignment. Cleats at the ends of the roller bars make it easy to align them with one another on the workbench and make a handy rolling surface for finishing projects.

Quick Tips



IRONING BOARD HELPER

Instead of tossing out an old ironing board, I repurposed mine as a handy shop helper for holding up cabinets as I fasten them to the wall.



BETTER SUCTION

I was tired of my floor nozzle getting stuck to my floors because of my shop vacuum’s strong suction. To raise the nozzle off the surface slightly, I epoxied a few washers on the underside of the nozzle.

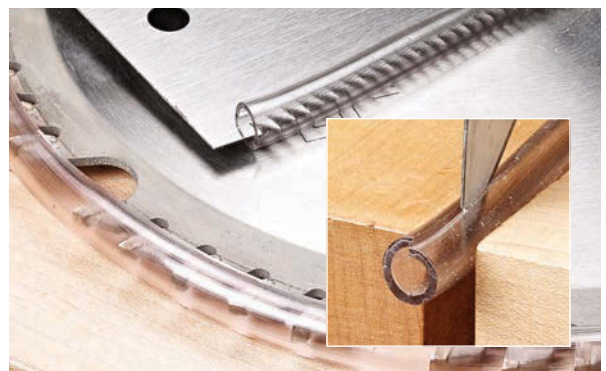

BLADE GUARD

I couldn’t justify the expense of buying blade guards for my hand and circular saw blades. Instead, I buy a length of inexpensive tubing and cut a slit down one side. I then cut them to length to fit all of my blades.

Carving Tool Caddy

Storing carving tools in a tool roll is a good solution for protecting the delicate cutting edges. But when I go to use them, I typically have to pull several out of the tool roll until I find the right one. In order to protect my carving tools, and make the cutting profile visible, I designed this carving tool caddy.

CLEAR VIEW. What sets this tool caddy apart are the two acrylic side panels that provide a clear view of the business end of my carving tools. Not only that, but I was also able to cut the slots in the block to exact size to match the individual carving tools in my set. And a couple of finger holes in each end make it easy to move around my shop.

PLYWOOD CONSTRUCTION. With the exception of the acrylic sides, the entire caddy is made from plywood and is held together with glue and screws. Glue up the material to make the block first. You can then lay out and cut the slots for your carving tools. To soften the rough edges, I chamfered the base and ends (including the finger holes). The screws holding the sides should be countersunk below the surface (inset photo).



NOTE: Size grooves in block to accommodate your carving tools

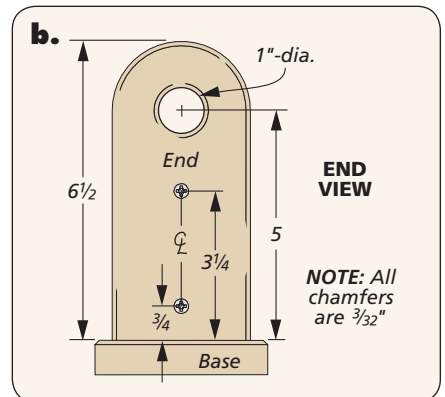
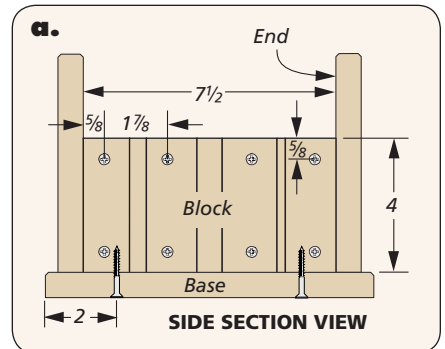
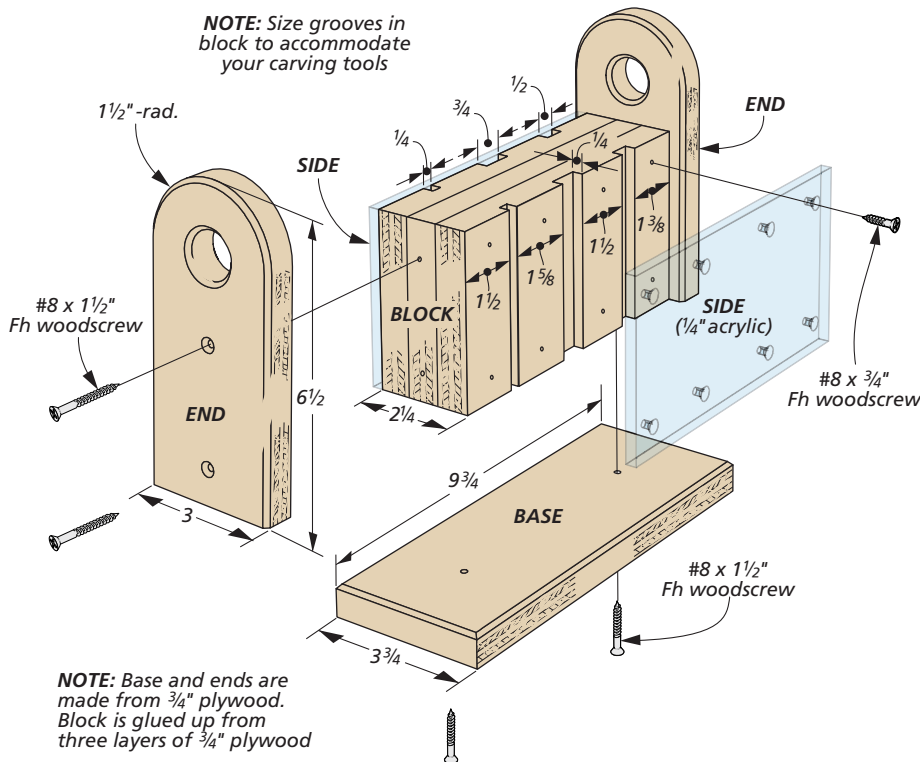



Notches. The notch in the rear of the shelf wraps around the shelf standards at the back where things can roll off.



Holes. The hole in front is sized to match the tab on the bracket. This locks the shelf in place, and lets you install a wider shelf.

Better Shelves for Standards & Brackets

Shelving made with store-bought shelf standards and brackets have a couple of downfalls. First, the brackets don't allow for very deep shelves. And second, because of the thickness of the standards, there's a gap left at the back

of the shelf that allows things to fall off. To solve both of these problems, I made wider shelves with notches in the back to close the gap (photo, upper right). A hole in the shelf locks into the front of the bracket, as shown at right.

Ruler Holder



Whenever I'm in the middle of a project, it seems I'm always fishing around for one of my rulers. So I made a home for them right on the side of my bench. This is a simple block of wood that I fashioned to fit my two

most-used rulers. A deep groove cut with a thin-kerf blade cradles them. A cutout in the center lets me select whichever ruler I need. And a rare-earth magnet grabs and holds the two rulers in place when I'm not using them.

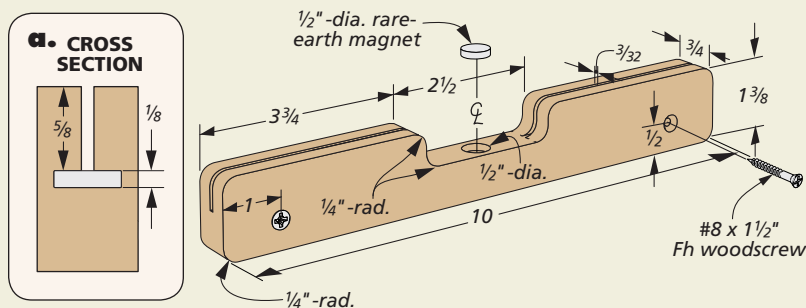

Mobile Light Stand

I recently replaced a rolling desk chair that had several tears in the seat fabric. Since the wheeled pedestal of the chair was still in perfect working condition, I decided to repurpose it and create this mobile light stand for my halogen shop light.

DOWEL CONNECTOR. After removing the tripod base from my shop light, I matched a length of large diameter dowel to the wheeled base and the bottom of the light pole. If one hole is smaller than the other, wrap some sheets of paper around the dowel to act as shims. Now my shop light is easy to move around the shop.

Quick Tip



TOOL HOLDER

I was having a problem with tools vibrating off my workbench whenever I used a power sander. To prevent this, I mounted a magnetic bar into a piece of hardwood and added a dowel to the underside to fit in a dog hole.



Cutoff Storage Bin

I used to spend too much time searching for the right dowel or cut-off. To solve the problem, I came up with the storage system you see here. Using 4"-dia. thinwall, sewer and drain pipe available at the home center, this bin provides compartmented storage for cut-off strips of differing lengths down to 12". The design allows me to quickly and easily find whatever piece I'm looking for.

CUT & ASSEMBLE THE TUBES. To make the storage system, you will need five 10' lengths of 4"-dia. pipe. Start with the longest length

first (48") and then cut each length 2" shorter than the previous one. (The last length will be 12".) This produces 19 individual tubes. Then use a band saw or a reciprocating saw to cut the tops at a 45° angle.

The 48" long pipe is the center tube.

Each progressively shorter length is fastened to it or the adjacent tube with 1/2" panhead sheet metal screws, in a spiral configuration somewhat like a spiral staircase.

MAKE A BASE. Cut a piece of 3/4" plywood to the dimensions shown for the hexagonal base and six pieces of 3/4" plywood for the base sides.

Screw the sides to the base using wood screws and set the tube assembly inside. Drive screws through the sides into the tubes to hold the assembly together. Finally, mount casters on each corner for mobility. Now I can place each cutoff in the appropriate tube so each piece is visible. And I spend a lot less time finding exactly what I need.

NOTE: Cut tops of tubes at 45°

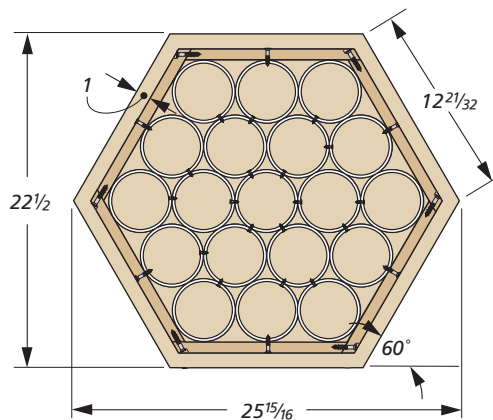
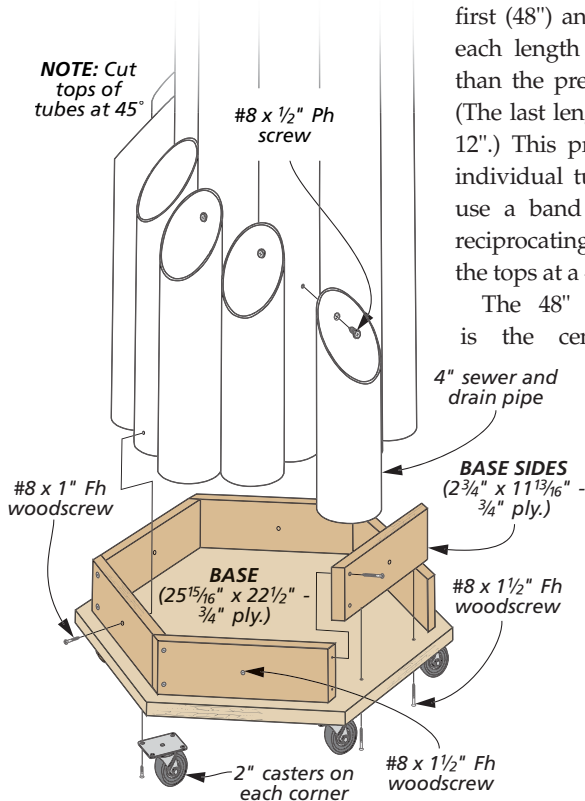

Small Parts Storage Caddy

Keeping track of small hardware bits and pieces is always a challenge. It seems that no matter how well the original packaging is resealed, they'll inevitably break open in drawers and cubbies. The contents will be scattered about, or worse, lost forever in the abyss.

To better contain my tiny hardware parts, I reused some inexpensive plastic water tubes that I had lying around and created this portable storage caddy. The water tubes are commonly used to hold cut blossoms and are readily available for less than 20 cents each.

PLYWOOD CADDY. The storage caddy is quick to put together using plywood parts. The top and bottom have tongues on the ends that fit into dadoes on the end pieces. Notches on the top edge of

the end pieces, as well as a long groove on the top, house a carry handle (detail 'a'). The holes for the water tubes should be sized to fit the tubes you have available.

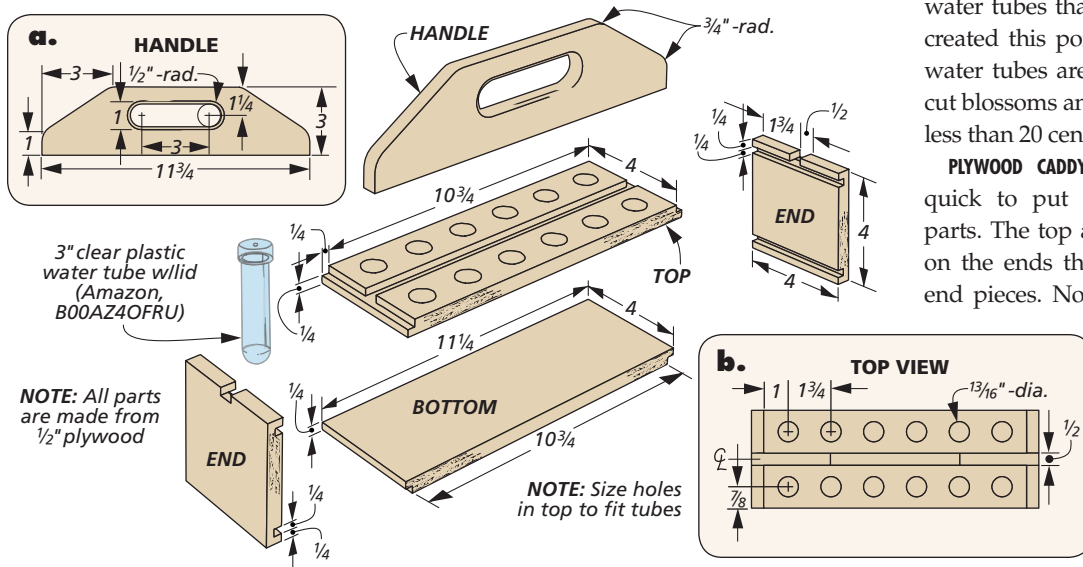

Quick Tips



SMALL VACUUM ACCESS

I had trouble maneuvering the large attachments that came with my shop vacuum to clean tight places. My solution was to slip a long, narrow funnel over the end of the hose to give my vacuum better access to those hard-to-reach areas.

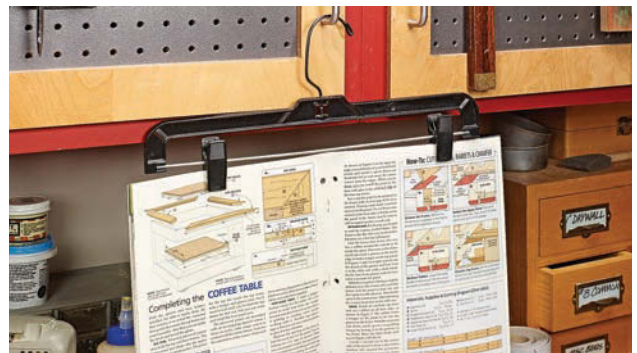

PLANS HANGER

I found another use for the department store clothes hangers that have spring clips on each end. I use them to hang my woodworking plans at eye level in my shop. It also keeps them safely off my workbench where they might get damaged.

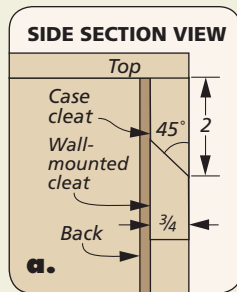

NOTE: Top, bottom sides, divider, and cleat are made from 3/4" plywood. Back and bases are made from 1/4" hardboard

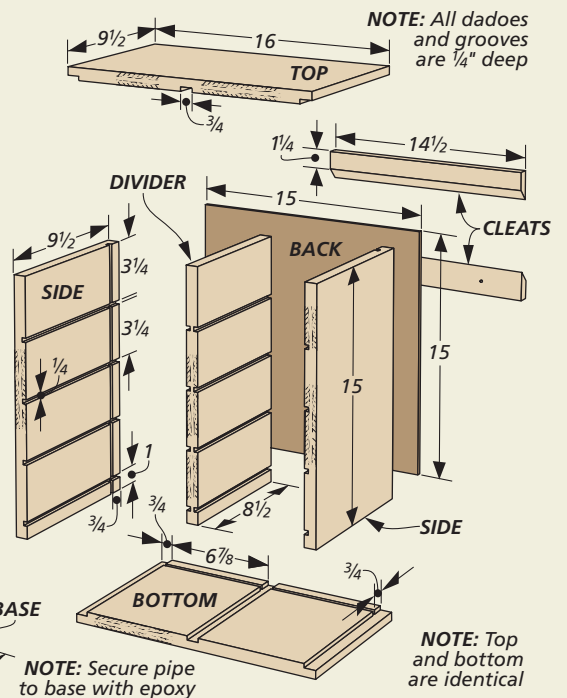
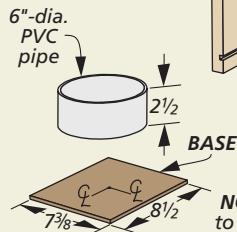

Sanding Disc Storage

My sanding discs always ended up floating around loose in the bottom of a workbench drawer. To help keep my discs better organized, I made the wall-mounted storage unit you see here. The case is just a plywood box made using rabbets and dadoes.

The sides and middle divider have aligning dadoes that allow the trays to slip in and out for easy access to the sanding discs. Shallow grooves in the top, bottom, and sides hold a hardboard back. I also added a beveled cleat to hang the unit on the wall.

Trays. With the case done, all that's left to complete this storage box are the sanding disc trays. They are nothing more than short pieces of PVC pipe that are each epoxied onto a square hardboard base, forming a small tray.

Lathe Tool Holder

Nothing is worse than having a woodturning tool roll off your workbench and crash into the shop floor. If you're lucky, you may only scrape the handle. If not, it may be off to the sharpening station to remove a chip in the cutting edge of the tool.

I had experienced this one too many times while working at the lathe. To prevent it from happening again, I built this tool rack to keep my turning tools close by, and more important, safe from damage.

SIMPLE CONSTRUCTION. I designed my tool rack to slip over the bed of my wood lathe. But it can be customized to fit other size lathes, as well. The sides have notches that act as the actual tool holders. These are easy to form at the band saw.

I also cut dadoes in the sides to hold the bottom platform. This platform should be cut to the width of your lathe bed, plus the depth of the dadoes. I then added a cleat to the underside of the platform that slips between the ways.

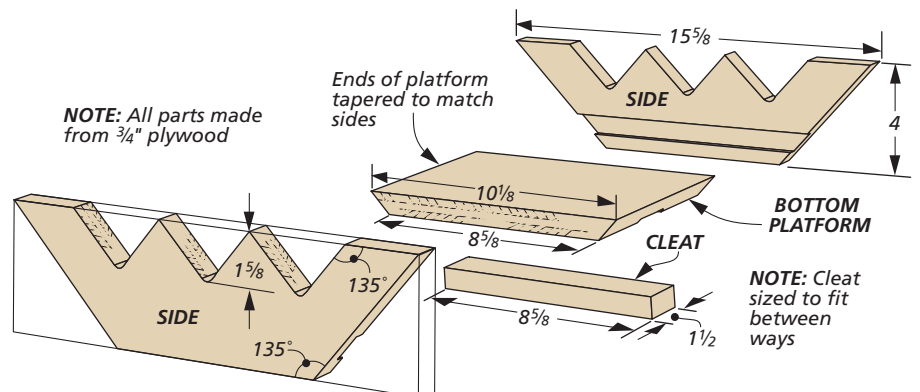

Quick Tips



VERSATILE TOWEL RACK

I attached an inexpensive swing-arm towel rack above my utility sink. The three-pronged model (shown above) is the perfect place to let paint brushes and other supplies drip-dry without making a mess on the countertops.



RECYCLED SANDING BLOCKS

Instead of throwing away my worn out sanding blocks, I get a second life out of them as glue spreaders. I simply taper the end with my band saw. The recycled blocks work perfectly for spreading glue on large panels.

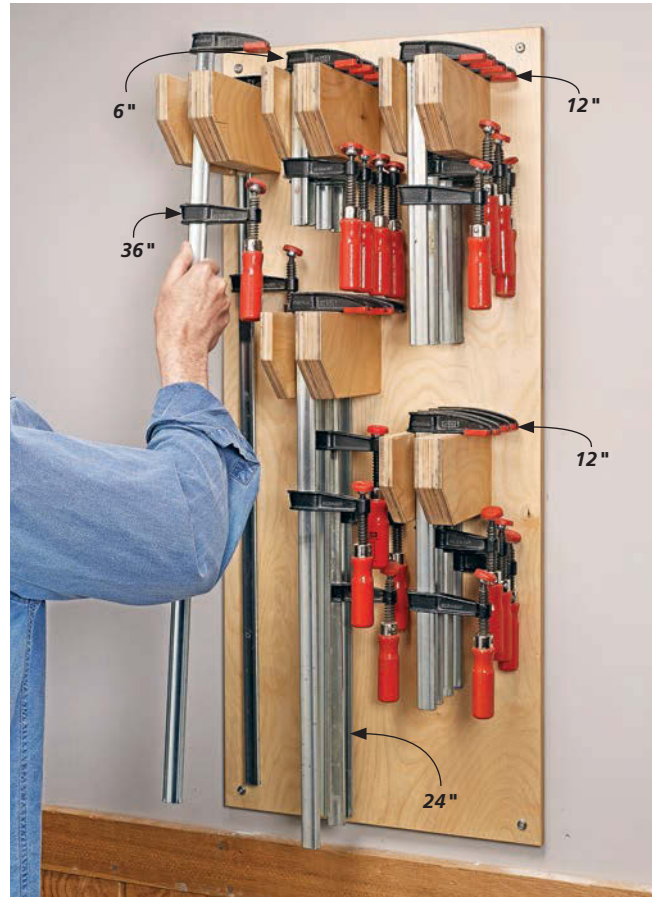
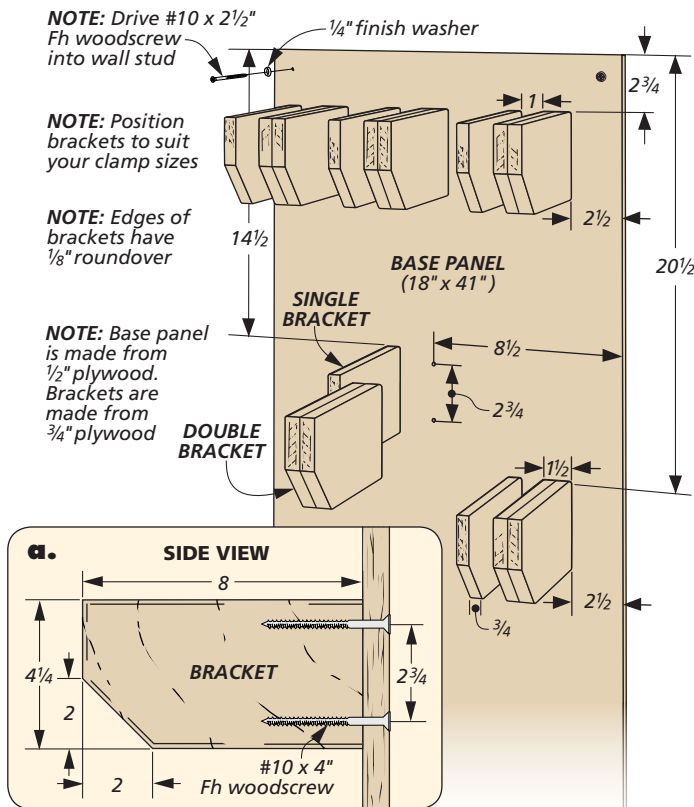

Space-Saving Bar Clamp Rack

Having accumulated a number of Bessey F-style bar clamps over the years, I eventually came to realize that stacking them on the shelf underneath my workbench wasn't the ideal storage option. They were difficult to get to, and I always managed to knock a couple off the shelf when picking them up. Since I had some free

wall space available, I decided to make this simple storage rack to get my clamps out from underneath my workbench and make them more accessible.

SIMPLE DESIGN. My storage rack allows clamps to be "stacked" in each pair of brackets to save space. The design of the single- and double-layer brackets cradle

the Bessey F-style bar clamps perfectly. The brackets are made from plywood and are fastened to the base panel with screws from the back side. As you can see in the photo, I positioned the brackets based on the length of the clamp bars. That kept the longer bar clamps from interfering with the clamp brackets below.

Overhead Storage Tray



My small shop doesn't have much room for storage. Especially when it comes to delicate sheets of veneer and various lightweight items that are easily damaged or misplaced. To solve this storage problem, I made this shallow tray that's mounted to the rafters in the ceiling. You can see how the tray goes together in the drawing at right.

CREATIVE MOUNTING SYSTEM. What's unique about this tray is the system for raising and lowering it. Each corner of the tray features eye bolts and snap links that match up with eye bolts on the rafters. Connecting the snap links with the rafter-mounted eye bolts holds the tray closed (inset photo).

Both front corners of the tray, however, also have a short length of chain that's connected between the eye bolts with quick links. To access

the tray, release the snap links and gently lower the tray until it's supported by the chains.

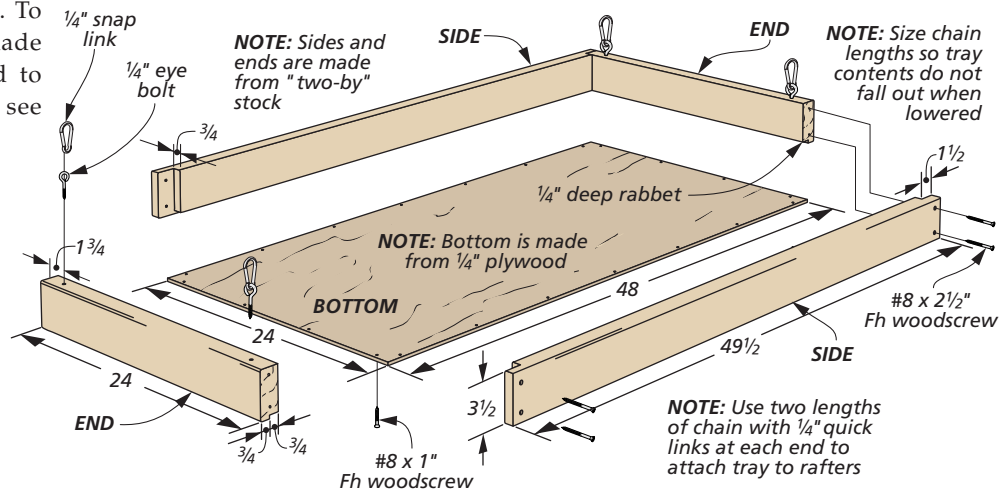

Quick Tips



FILE & CHISEL PROTECTORS

I don't like my files and chisels rolling around and getting damaged in my workbench drawer. To keep them protected, I use inexpensive pipe insulation. This insulation has a slit in the side and is easy to cut to length for each tool.



GLUE CUP & BRUSH KEEPER

To keep my glue brush off my workbench and at the ready, I made this simple glue station for my shop. It's simply a block of wood with a large hole near one end to hold a plastic cup and a groove to hold the glue brush.

Knock-Down Worktable



Throwing a sheet of $\frac{3}{4}$ " plywood on a couple of sawhorses to use as a temporary worksurface is a pretty common practice for many woodworkers. However, moving and storing these large sheets can be cumbersome and back-breaking. My solution was to make a knock-down worktable that could be moved and stored in sections.

BUILD THE TABLE. The tabletop is made up of three wide boards. Be careful to pick boards that are straight and relatively flat. I installed inexpensive hinges at the mating ends of the boards, as shown in the main photo. Several evenly spaced dowels positioned along the edges of the boards helps to keep the surfaces aligned during use.

Whenever I need a quick worksurface, it's easy to position the boards on sawhorses one at a time. Line up the hinges and tap the hinge pins in place to keep the table locked together. The dowels will ensure everything lines up quickly and easily.

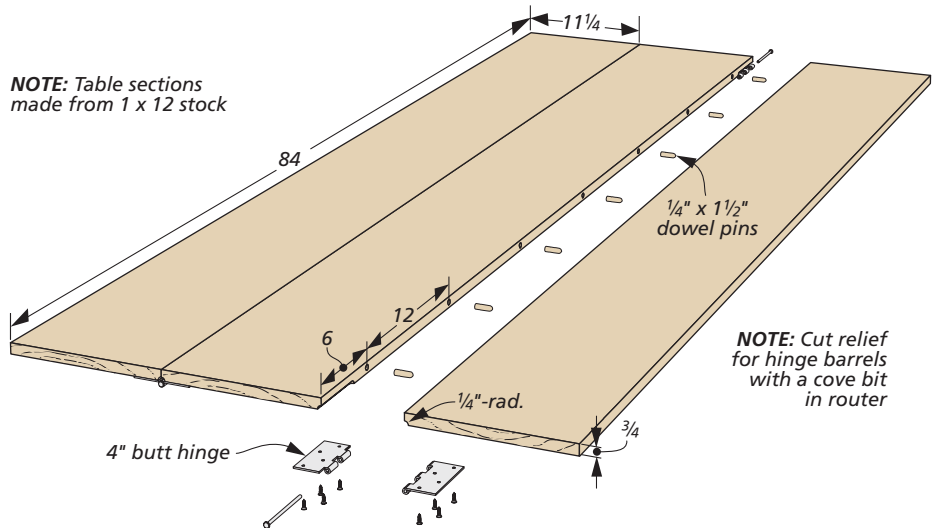

Quick Tips



MOVABLE TASK LIGHT

Instead of installing fixed task lighting to the tools in my shop, I bought a couple battery-powered puck lights. Velcro strips attached to the back of each light make them easy to move where they are needed.

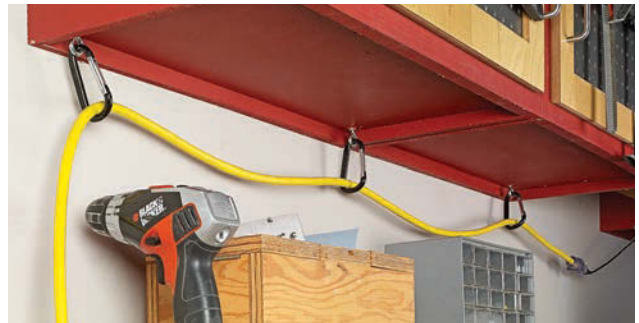

CARABINER CORD HOLDER

I keep several carabiners in my tool box. They come in handy for temporarily suspending power cords overhead and out of the way. They're easy to install and quick to remove when not needed.



Drawer-Slide Tool Mount

Workbench space is at a premium in my small shop. So permanently attaching bench-mounted tools (like my grinder) in a convenient position at the front edge of the bench is not an option. Instead, I made a simple pull-out platform that allows me to slide my grinder to the front edge of the workbench when I need it. Then I simply slide it back to free up the space for other work (upper inset photo).

The platform is just a few layers of plywood assembled with glue. A hardwood front covers the plywood edges. A pair of full-extension drawer slides are mounted to the sides and platform. The sides are screwed to the workbench. I added a hand-hold in the platform and front fillers for convenience. To hold the platform in place while in use, I installed a couple barrel bolts on the front (lower inset photo).

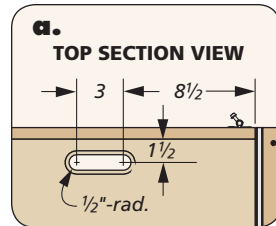

NOTE: Platform and fillers are made from 3/4" plywood. Front and sides are made from hardwood

NOTE: Drawer slide length should be half the depth of workbench

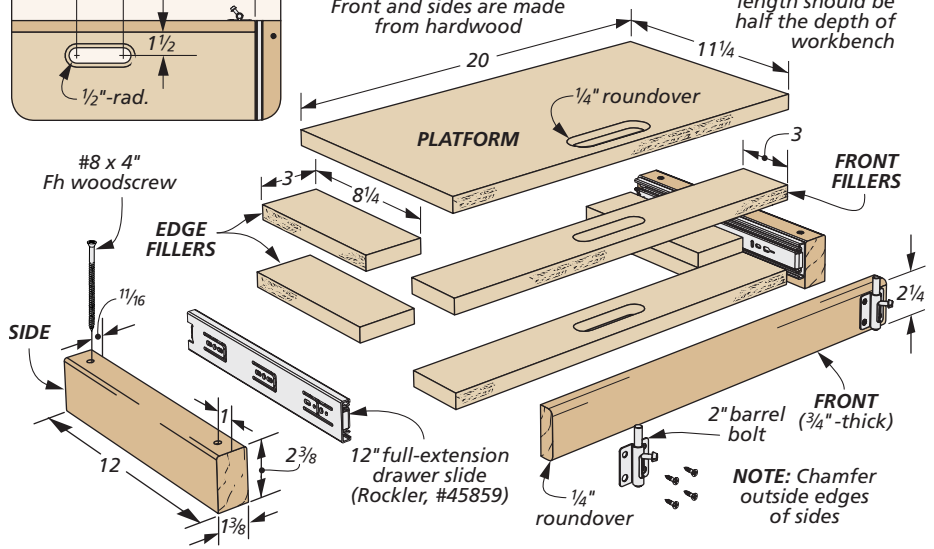

Quick Tips



HANDY CUPCAKE LINERS

To keep from making a mess on my workbench, I use foil cupcake liners to mix epoxy. The liners are small and can be held in one hand. They can be folded to pour the contents and, best of all, they're disposable.



EASY-ACCESS MEASURING TAPE

To avoid misplacing my tape measure in the shop, I took a few identical tape measures and replaced the belt clip with a rare-earth magnet. This allows me to keep one attached to each major tool in my shop.

Low-Cost Folding Sawhorse



Recently, I needed to replace some old and badly damaged sawhorses in my shop. My goal was to construct a light-duty, folding sawhorse using only one 8'-long piece of 1x4 stock and a small piece of 1/4" plywood. This design I came up with was so inexpensive to build, I decided to make several.

SADDLE, LEGS, & BRACKETS. The first order of business is to cut the top beam to size from the 1x4 stock. Go ahead and lay out and predrill the holes in the beam for attaching the legs and brackets later on. I then ripped the remainder of my 1x4 board down to use as legs and brackets.

As you can see in the plan below, the legs on the opposing sides of the sawhorse's top beam are actually different lengths with different profiles cut on the top end. As you cut them to size, be sure to label them to ensure they're mounted to the correct side. The brackets can now be cut to size and mounted to the beam along with the legs. A couple carriage bolts and lock nuts allow the legs to pivot closed.

STRETCHERS & BRACES. I screwed a plywood stretcher to each side to add rigidity to the sawhorse. The braces can now be added to the legs. One end of each brace is notched to fit over the shank of a hex bolt in one leg on each end. This keeps the sawhorses locked open. Another hex bolt further up the leg locks them closed.

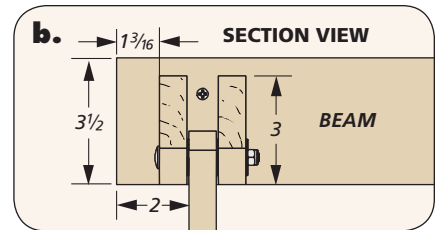
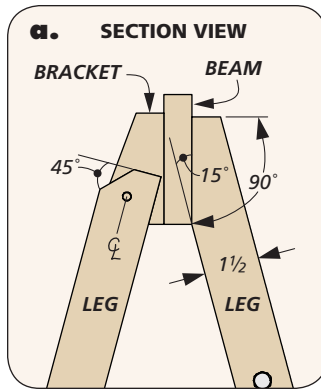
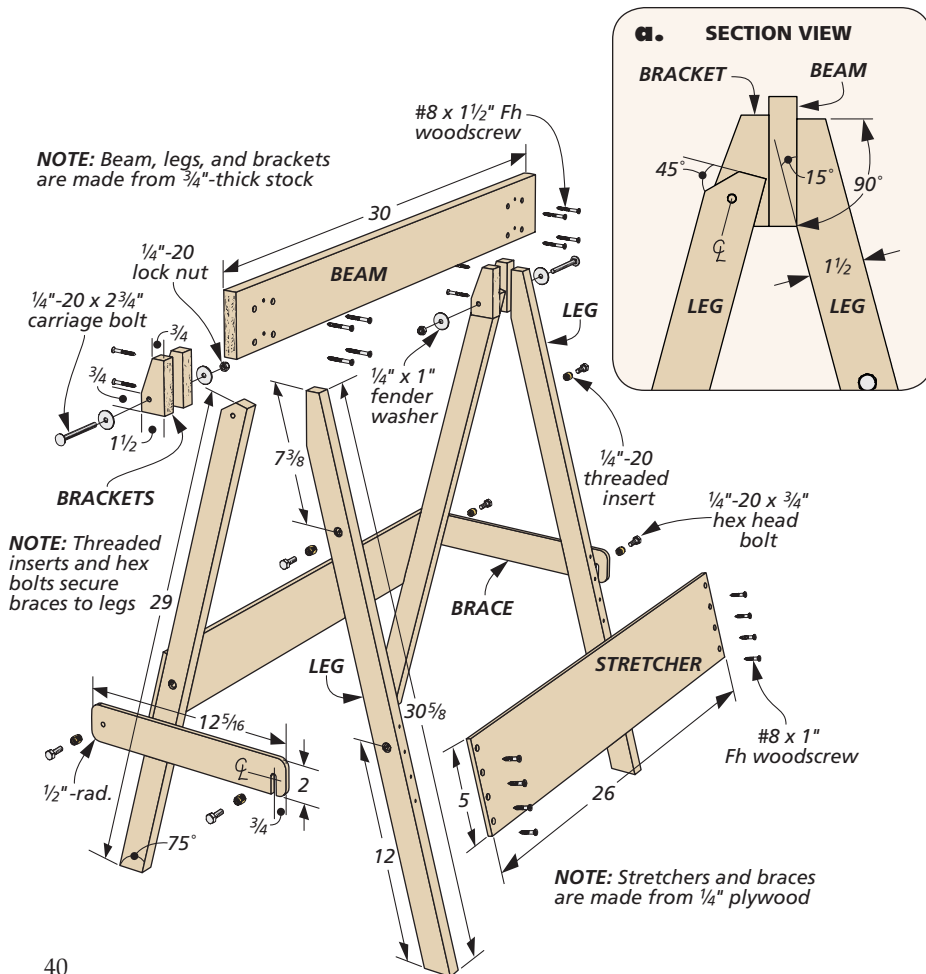

Compact. The sawhorses fold for storage. The braces hook onto a bolt on the leg to keep them locked in the closed position.

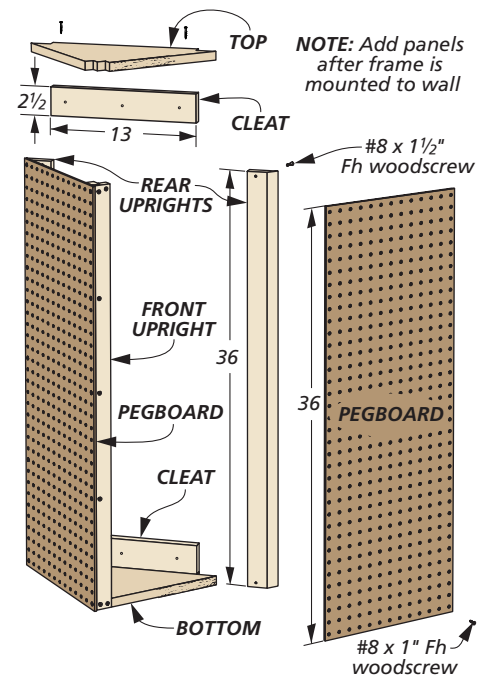

3-D Pegboard Rack

One day while working at my bench, it occurred to me that I could gain additional storage space on my pegboard rack without increasing the size of the footprint on the wall. To do this, I made the panels into three-dimensional sections, as shown in the photo at right.

THREE FRAMES. Each section consists of a triangular frame with two pieces of pegboard attached to the front face of each frame. A pair of cleats on the back of the frame provide a surface for mounting each section to the wall. And the top and bottom panels, along with the uprights, add rigidity to

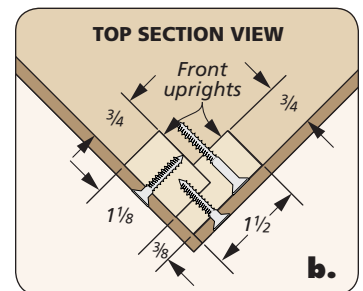
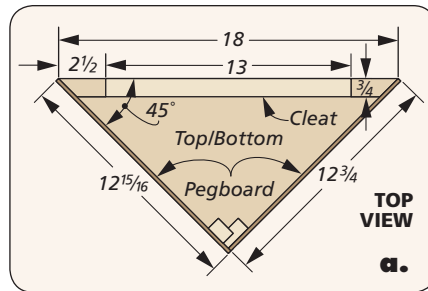

the assembly. The top panel even doubles as a small shelf. I mounted the frames to the wall through the cleats before screwing the pegboard sections to the frame. This configuration as shown added over 40 percent more surface area.

Quick Tips



QUICK WHITEBOARD

Tired of searching for notes that I jotted down on scraps of paper, I turned some of my shop doors into big note pads. Vinyl peel-and-stick whiteboard decals found online can be cut to fit inside the door frames.



SMALL PARTS TRAY

Instead of pitching an old keyboard tray, I installed it under my workbench. This gives me an additional surface for holding tools and project hardware. I just slide it away when it's not needed.

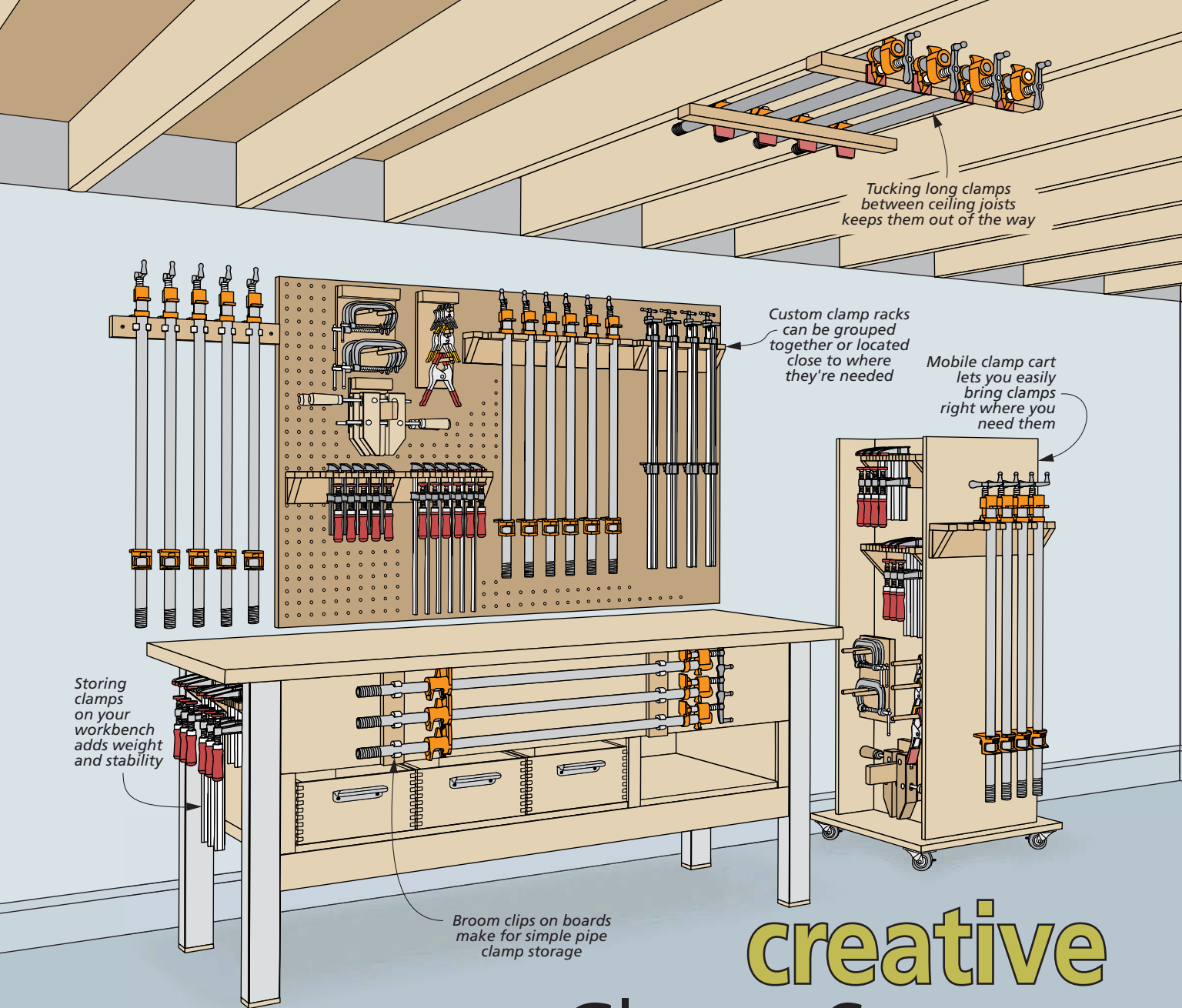

Tucking long clamps between ceiling joists keeps them out of the way

Custom clamp racks can be grouped together or located close to where they're needed

Mobile clamp cart lets you easily bring clamps right where you need them

Storing clamps on your workbench adds weight and stability

Broom clips on boards make for simple pipe clamp storage

creative Clamp Storage

There's no such thing as too many clamps, but storing them all can be difficult. Here are a few ways to organize and store the clamps you have in your shop.

Following the old workshop proverb, "You can never have too many clamps" means you're prepared for any type of assembly challenge. But you're also faced with storing all those clamps.

No matter how many clamps you have, the right kind of storage system can help keep project assembly less hectic. I talked with a few editors around here to learn

their strategies for storing and organizing clamps. The drawing above serves as a gallery of their ideas. The advantage here is you can pick and choose a solution or two that can work in your shop. While each situation is unique, I want to touch on a few common themes.

WHERE YOU NEED THEM. On the surface, keeping all your clamps in one place

makes sense. However, just because they're all clamps doesn't mean you use them the same way.

For example, one of our editors has a dedicated assembly area between his workbench and workshop machines. So on the closest wall (upper left side of drawing), you'll find his bar clamps within easy reach.

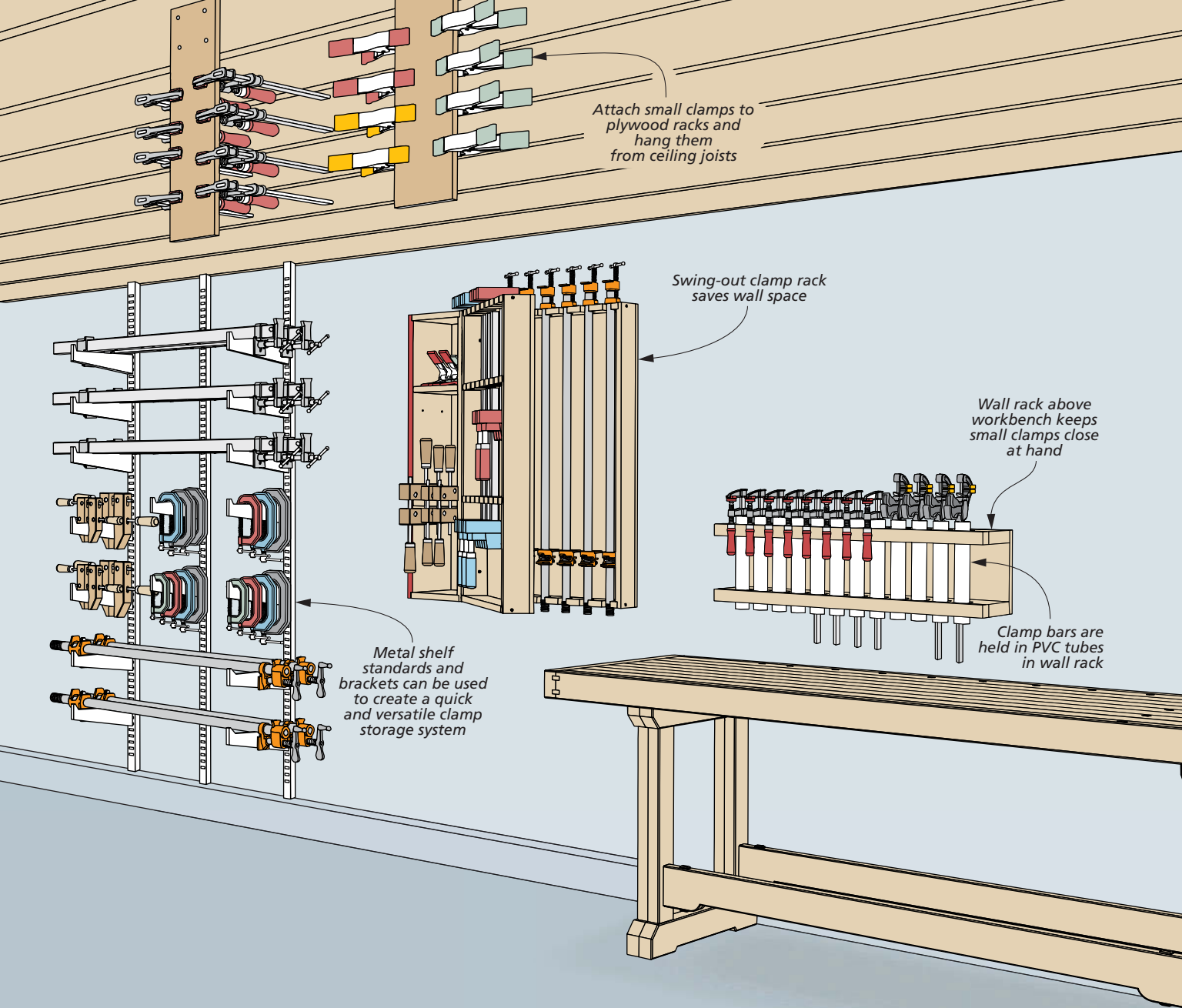

Attach small clamps to plywood racks and hang them from ceiling joists

Swing-out clamp rack saves wall space

Wall rack above workbench keeps small clamps close at hand

Metal shelf standards and brackets can be used to create a quick and versatile clamp storage system

Clamp bars are held in PVC tubes in wall rack

On the opposite side of his bench, he built racks for his small clamps. These are used more often while working at the bench.

TUCK THEM AWAY. There's a good chance you have clamps that you don't use very often. But when you need them, they can be real problem-solvers. Specialty clamps like band clamps or long bar clamps are just two examples. For these clamps, it's better to stow them out of the way of typical shop activities. But you still want to get to them when you need to.

One good place for long pipe clamps is on the back side of a workbench.

A nice side benefit is that the added weight provides additional ballast to make the bench more stable.

Look overhead for out-of-the-way storage. You can tuck long clamps between ceiling joists. In the drawing you can see a couple of simple racks for holding small clamps that hang from the joists.

ALL TOGETHER NOW. Earlier I talked about organizing clamps based on use. But depending on the number of clamps you have and the layout of your shop, keeping all your clamps together can be just the ticket.

The compact clamp cart you see in the middle of the drawing gives editor

Bryan Nelson the flexibility to roll the clamps right where he needs them. In the meantime, the cart can sit in a corner out of the way.

Rather than take time to build a custom storage for your clamps, pick up some basic shelf standards and brackets at a home center. The adjustable brackets can be used to hold just about any kind of clamp without taking up a whole lot of space.

Organizing clamps is about more than just keeping your shop tidy. The right kind of storage can make working with clamps in your shop easier and more enjoyable, too. **W**





hands-on Techniques

The best tool in any woodworking shop is knowledge. Possessing the practical ability and tool mastery required for every task at hand is essential. These techniques are sure to come in handy in that effort.

HINGE MORTISE TIPS & TRICKS.....46

INSTALLING DRAWER GUIDES.....48

TIPS & TECHNIQUES.....50

7 TIPS FOR PERFECT PANELS60

hinge mortise Tips & Tricks

Get tight and precise hinge mortises using these simple techniques.



Correctly installed hinges are one of those last-minute details that often go unnoticed on a finished piece. But if the hinges aren't installed with care, the lid or door won't fit right or operate properly. It all starts with how you prepare the hinge mortises. A properly fitting hinge mortise is a sign of good craftsmanship.

The good news is, there are several ways to get the job done. It's all a matter of which technique you're most

comfortable with. Plus, this gives you the opportunity to learn some new techniques and put them to use.

NO MEASURING. The first thing to do is set aside your ruler. For all of the techniques shown here, the best layout tools are the hinges, a knife, and a marking gauge. I like to wrap the hinge around the edge of the workpiece and score the outline of the leaf with a knife (left photo below). It's best to make several passes, especially

across the grain. This helps prevent tearout when removing the waste. It also creates crisp edges for the mortise.

It's also helpful to mark a guideline for the depth of the mortise. My favorite tool for this task is a marking gauge. Use the leaf of the hinge as a guide to set the fence of the marking gauge, then score the workpiece, as shown in the right photo below.

With those two tasks done, you can use one of the techniques shown here to create the mortise.

CHISEL

A chisel is one of the simplest tools for creating hinge mortises. The drawings at the top of the opposite page show the quick and easy process I use.

SCORE & PARE. The first step is to make a series of light, cross-grain cuts by using a mallet to tap the chisel. This severs the long grain into shorter segments, making it easier to pare away the waste to the proper depth.

Then it's time to switch to more of a slicing action to remove the chips.

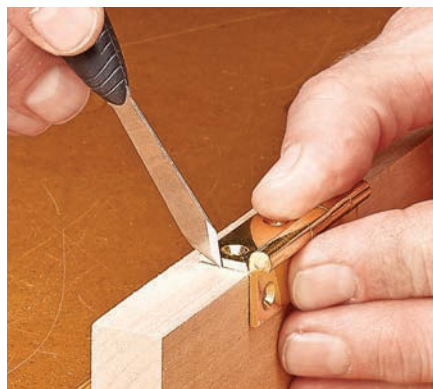

Establish the Outline. A sharp marking knife makes quick work of scoring deep lines for crisp mortise edges.



Mark the Depth. I like to use a marking gauge to score the final depth of the hinge mortise before removing the waste.

Here, it pays to go slow and make several passes, going deeper with each pass. Use the leaf of the hinge to gauge your progress on the depth of cut. The goal is for the leaf to sit flush with the surface. And it's important to maintain control of the chisel during this step to avoid cutting beyond the mortise.

HAND-HELD ROUTER

Another tool that's great for removing the bulk of the waste is a compact router. You can see how it's done in the main photo and in the illustrations below.

ROUTER SETUP. After marking the outline of the mortise as before, install a 1/4" straight bit in the router. Use the hinge leaf as a guide to set the bit depth.

To help support the router on the edge of a workpiece, it's a good idea to clamp scrap pieces to the sides of the workpiece. You'll want to keep them flush with the workpiece for routing to a consistent depth.

Then it's a matter of plunging the router into the waste area of the mortise and carefully working close to your scored lines. A chisel makes easy work of cleaning up the rest of the waste.

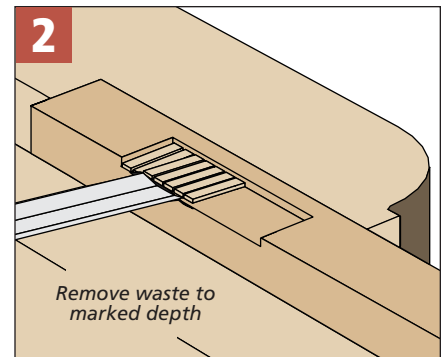
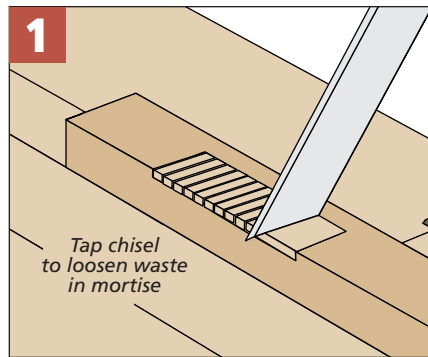
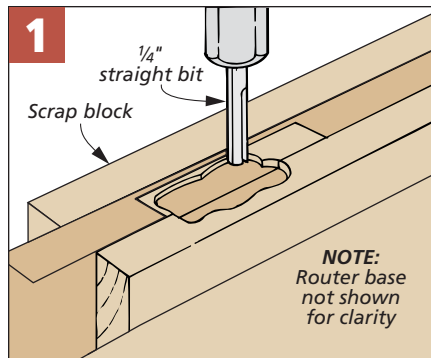

ROUTER PLANE

A final hand tool that can be used for creating hinge mortises is a small router plane. It's ideal for removing thin shavings to sneak up on the perfect depth of the mortise (left photo below).

MARK & SCORE. After scoring the outline of the mortise, I like to go a step further. I use a chisel to deepen the ends of the mortise. This provides a clean edge for the router to break away chips when removing the waste.

SLOW & STEADY. To set the depth of the blade in the router plane initially, I set the body of the plane on a couple thicknesses of paper with the blade resting

on the bench. Then slice away the waste inside the scored lines.

I start by working carefully into each end of the mortise then removing the remaining waste in between. Take it slow and easy while maintaining tight control of the plane. It's easier going if you remove thin shavings instead of large chunks. Make progressively deeper passes until you reach the final depth.

If you find that you enjoy the process of cutting mortises with hand tools, see the box below. No matter which technique you decide to use, the results will speak for themselves. **W**

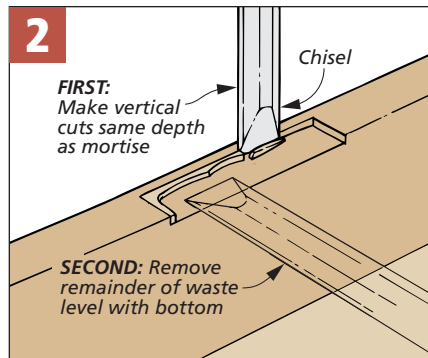

Control. Dual knobs allow you to maintain tight control when removing waste.

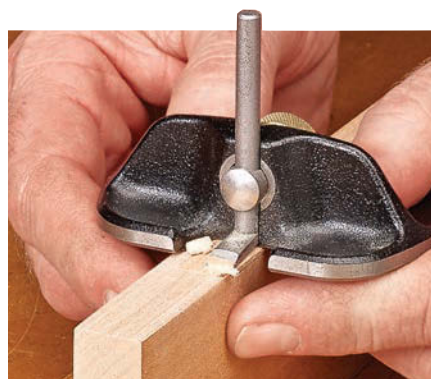

Make Shallow Cuts. Use the router plane to carefully remove the waste by making several passes to final depth.

Mortise Plane

Hinge mortise planes have been around for over a century. They excel at paring away the waste to create a hinge mortise. This *Veritas* plane works a lot like a router plane. As a matter of fact, it uses the same blades.

The pair of knobs on the plane make it easy to control. And you can easily fine-tune the depth for a perfect fit every time.



installing Drawer Slides

The secret to perfectly aligned, smooth-sliding drawers is to take the right approach to the installation process.



Building drawers that slide smoothly while holding a lot of weight is a tall order for traditional wood drawer guides. Over time, wood components wear down, and seasonal humidity changes can cause drawers to stick. In addition, wood drawer guides don't give you complete access to the contents of the drawer.

The solution to these challenges is to use side-mount, full-extension drawer slides. While they aren't appropriate for a period furniture reproduction, I do use them on many shop and furniture projects where reliable operation is a must.

TWO PARTS. On the surface, metal drawer slides seem as if they'd be a hassle to install accurately. The key to simplifying the process lies in the fact that the slide

separates into two components. The smaller part gets attached to the drawer box, and the larger piece mounts to the case (more on this part later).

BETTER SCREWS. Before going any further, I want to take a moment to talk about the screws. Many slides come with screws. But if they're ordinary round-head screws, I toss them and order washerhead screws that are designed for installing slides, as shown in the lower left photo. The washerhead screws have a low profile. A large bearing surface and deep threads ensure a strong grip.

THE RIGHT LOCATION. One of the benefits of using full-extension slides is you have a lot of freedom in locating the hardware on the drawer sides. The truth is, unless

they're special-purpose slides, you can attach them almost anywhere you like on the drawer box.

That being said, I have two primary locations for the slides. These are shown in the drawings below.

Probably the most common location is to center the slides on the width of the drawer sides, as shown in the left drawing. The other location is flush with the bottom of the drawer box, as in the photo above and the lower right drawing.

When attaching the slides to the drawer box, it's a good idea to drive screws through the vertically slotted holes first (far right drawing). This gives you room to adjust the position up and down for the best performance and look.

Screws for Slides.

These special screws have a wide, low-profile head, and the deep threads can start without a pilot hole.

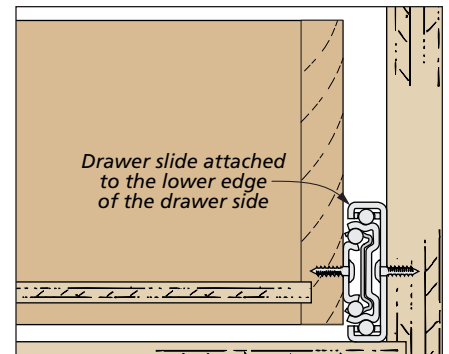
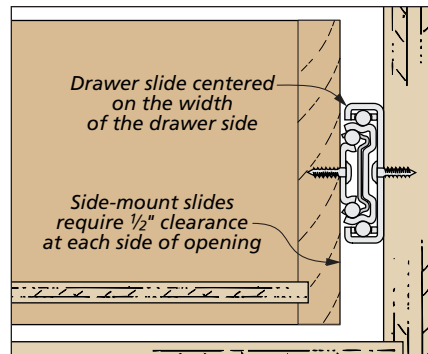



Spacer. Cut a spacer to support the drawer slide in the correct position. Rest the drawer slide on the spacer and install the screws.

CABINET COMPONENT. Attaching the slides to the drawer boxes is pretty straightforward. Installing the other half of the hardware is a little more involved. That's because you're working inside a cabinet where things may be a little cramped and dark. In addition, you need to make sure each pair of slides are installed consistently side to side.

The method I turn to for this task is highlighted in the three photos above. The secret is an MDF spacer. This supports the slide and guarantees that each part is aligned. Then it's just a matter of starting at the top and working your way down. This way, previously installed slides won't get in your way. And you can just cut the spacer down to line up the next pair. Here again, use the slotted holes (running side to side). This will allow you



Adding a Second Slide. Measure and mark the location of the next pair of slides on the case. Then cut the spacer to match.

to fine-tune the front-to-back position of the drawer in its opening.

Completing the installation process means you're ready to put the drawer into place and fit the two components back together. Carefully line up each part and slide the drawer box in. You'll feel a little resistance here. Don't be surprised. That's just the way the parts reengage.

Once the drawer is installed, it should operate easily. If it doesn't, take a look at the box below for two remedies.

DON'T STOP NOW. Once both parts of the slide are installed and you're satisfied with the fit and movement, there's one last step that's easy to overlook. That's to add screws to the round, fixed holes in both components of the slides. It may seem like overkill, but without these screws, the slide mechanism will likely



Repeat. Clamp the spacer in place and continue the installation process. Repeat the steps until all the slides have been installed.

creep out of alignment over time. If you pay attention to these few details, you're guaranteed to get the best performance from full-extension slides. The result is drawers that you can rely on to carry a heavy load and operate smoothly year after year. **W**

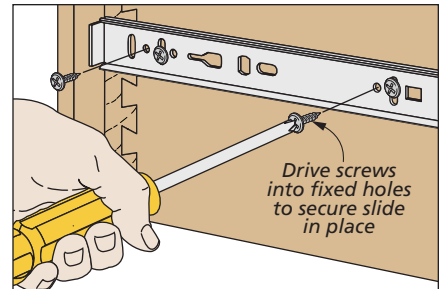

Install. Complete the installation process by driving screws into the fixed holes in both the drawer (shown) and case components.

How-To: Fitting the Drawers

After taking the steps shown here, you may find that a drawer isn't opening and closing as smoothly and effortlessly as possible. The problem may just be the size of the drawers. Carefully measure the drawer opening, the drawer box, and the thickness of the drawer slides. Drawer slides have enough play to tolerate a slight variation in the size of the drawer. But if the drawer is too large or too small, that can stress the mechanism.

Too Small. If you find the drawer box is too narrow, shim one or both sides of the cabinet portion of the slides. You can

use card stock, brass shims, or even washers. Don't feel you need to shim both sides evenly. The small amount of shimming isn't noticeable.

Too Wide. The solution for a wide drawer is to trim the drawer to tweak the fit. You can do that simply by jointing the side.

Or you could cut a shallow groove in the drawer side if it's slightly too wide. The setup is the same as cutting a rabbet by burying a dado blade in an auxiliary fence (or cutting a wide groove if the slides are centered.) Trim one or both sides of the drawer until you get a smooth-sliding fit.

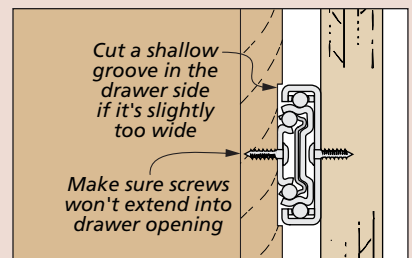
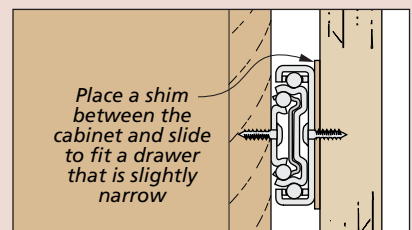

Dado Blade Setup Jig

In the past when I've set up a dado blade, I picked out the chippers I thought would get me close and then made the fine adjustments by taking them back off the saw to add the shims. The jig you see here makes the setup much easier by allowing me to make these adjustments before installing the stack on the saw. To use the jig, I simply lay a scrap piece along the stack and then add chippers and shims so the teeth are flush. Snug down the wingnut to compress the stack. Then you can transfer the stack to the saw.

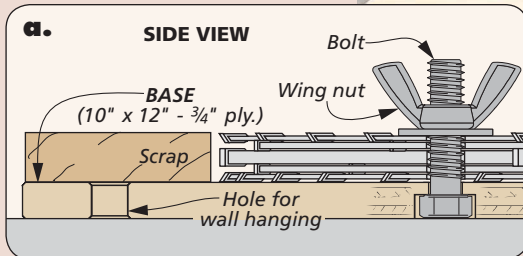
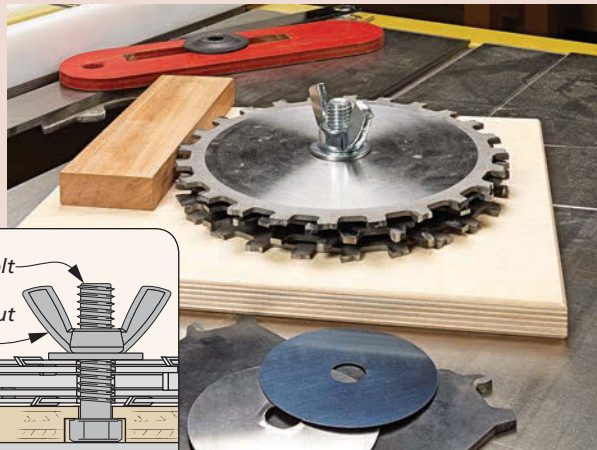

Sandpaper Cutting Board

It's amazing how many different sizes of sanding sheets you need in the shop. To simplify things, I made a jig that eliminates the measuring and can be configured to cut various sizes to fit your sanders and sanding blocks.

A spring-loaded, hinged panel holds the sandpaper flat and acts as a straight edge for cutting. Removable bolts placed in holes positioned on the board create stops to cut each size of sandpaper. You can write notes and labels on the plywood for each size you need to cut.

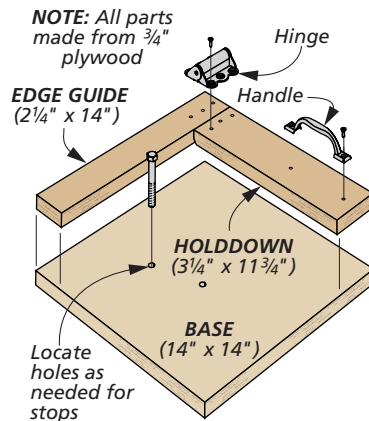

Quick Tips



POCKET SCREWS IN TIGHT PLACES

Recently, while building a fireplace surround for my home, I realized I couldn't install pocket screws in a tight space with my drill driver. Instead, I switched to a small ratchet, $\frac{1}{4}$ " socket, and drive bit to get the job done.



HANDY VACUUM BASKET

To hold attachments and tools that I often use along with my shop vacuum, I fastened a wire basket to the handle at the top of my vacuum. The open mesh doesn't collect dust, so the tools remain (mostly) clean for the next time I need to use them.

Quick Tips



ROUTER BIT CUSHIONS

I like to drop a small piece of pipe insulation into the collet of my router before inserting the bit. This prevents my router bits from bottoming out and potentially loosening up during use or causing excessive vibration.



ALIGNED THREADED INSERTS

Driving threaded inserts straight and true into their pilot holes can be challenging. I use an extension on my socket wrench along with a square to help install threaded inserts straight.

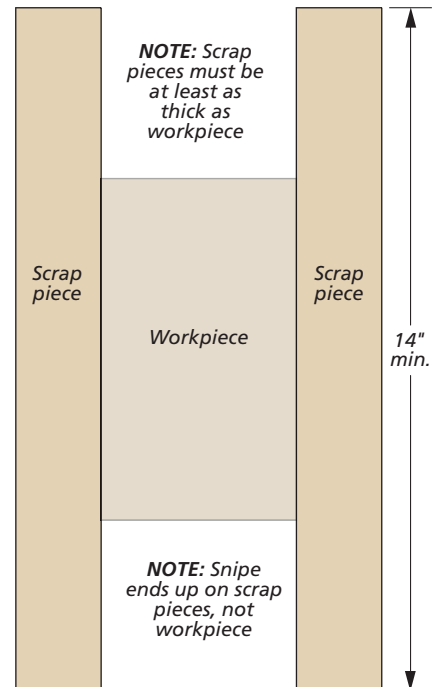

Planing Short Boards

I can never bring myself to throw away the short hardwood pieces left over from a project, especially if they're exotic or expensive. They're often ideal for small projects. But they typically have to be planed to thickness before I can use them.

The problem is that running a board less than 12" long through some planers isn't recommended. It can get caught

between the infeed and outfeed rollers, causing it to lift off the planer bed. At best, this causes severe snipe (a deeper cut near the end of a board). At worst, the board can get chewed up, damaging the cutterhead in the process.

To prevent ruining the board, I glue long, narrow scrap pieces to both edges of the piece I want to plane (illustration

above right). Inexpensive pine or fir works well here. These scrap pieces span both feed rollers, so the board stays flat on the bed of the planer. The result is a planed surface that's mirror smooth. If there's any snipe, it ends up on the scrap pieces, not the board. Once the board is planed, just cut off the narrow scrap pieces at the table saw.

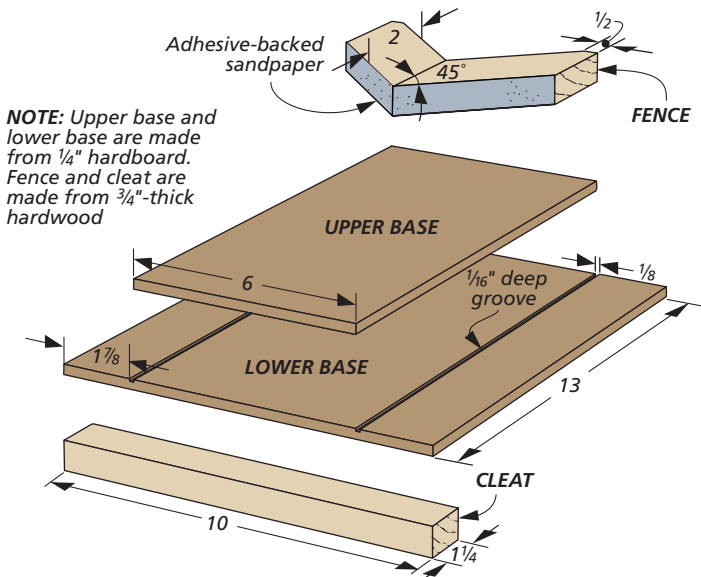

NOTE: Upper base and lower base are made from 1/4" hardboard. Fence and cleat are made from 3/4"-thick hardwood



Small Parts Miter Trimmer

Cutting miters by hand using my miter box gets me close to the final length on small workpieces. But it doesn't quite get me the perfect fit I'm looking for.

To produce tight-fitting miter joints on small parts, I made the small parts miter trimmer shown above. This handy jig makes it easy to hold a piece at a 45° angle while shaving the mitered end with a block plane (inset photo).

EASY BUILD. The construction of this small parts trimmer is pretty simple. It consists of a two-piece hardboard base, a 90° fence, and a bottom cleat. The upper base aligns the plane as it trims, and the lower base has grooves for keeping chips out of the path of the plane.

The fence is built from two pieces of 3/4"-thick hardwood with 45° miters on both ends. The key to getting perfect miters with this trimmer is installing the fence so it sits at a precise 45° angle with the base. Also, it's equally important that the ends of the fence line up flush with the edge of the upper base.

The last part of the small parts trimmer is a 3/4"-thick hardwood cleat. It fits against the edge of the bench, holding the whole assembly in place during use.

After the pieces are glued together, attach sandpaper to the fence to keep workpieces from slipping. Then, it's just a matter of trimming the mitered ends of the parts so they fit tight.

Quick Tip

FLATTEN BOWED PLYWOOD

I use this clever method to flatten bowed pieces of plywood. Simply wet the concave side of the plywood and then set the piece on some riser blocks. Finally, place a heavy weight on the convex side. It will straighten the piece out in no time.



Button Box Feet

To finish off a small box, sometimes all I need is a simple means to slightly raise the box. I've found that small button plugs work perfect for the job.

To install, you only need to drill shallow holes in the bottom of the box for the plugs to slip into. The plugs are then glued in place. And if the box doesn't sit flat, simply run the plugs over a piece of sandpaper on a flat surface to level things out.

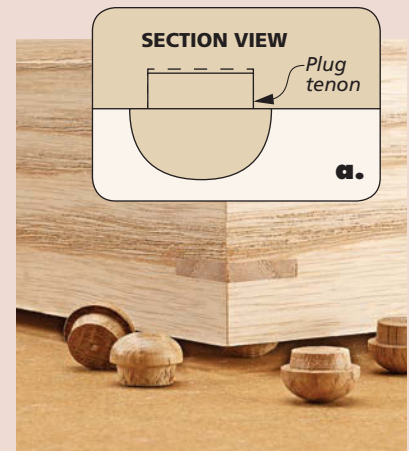

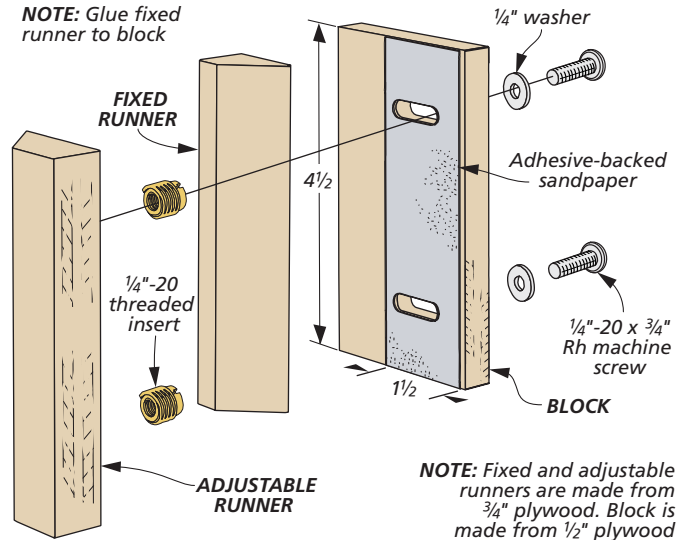
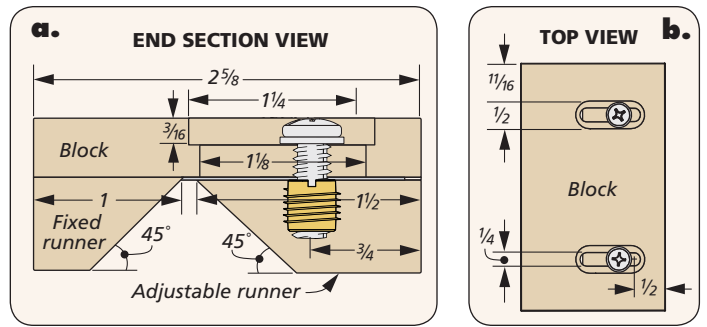

sandpaper in place. When the desired chamfer width is set, tighten down the screws and start sanding. Stop sanding when both runners make contact with the workpiece.

This sander can be set for a 1/4"-wide chamfer. But for anything wider than 1/8" it's probably best to turn to a hand-held router.

Chamfer Sander

Sanding a chamfer is a quick way to soften the sharp edge of a workpiece, but it takes some careful sanding to keep the angle and width of the chamfer uniform. To make the task easier, I built a chamfer sanding block that has two runners to guide it along the edge. This way, the angle stays at a consistent 45°.

QUICK BUILD. I made the two runners by ripping a piece of plywood with the blade tilted to 45° and then cutting them to length. One of the runners is glued to the block, but the other can be moved in and out to adjust the width of the chamfer. To make this runner adjustable, I routed stopped slots in the top face of the block and installed threaded inserts in the adjustable runner. The parts are then held together with machine screws.

USING THE SANDER. I attach a strip of 1 1/2" wide, 180-grit adhesive-backed sandpaper to the flat portion of the block, as shown in the drawing. Installing the adjustable runner helps hold the

Flattening a Worn Waterstone

The center of a waterstone gets the most use no matter how careful you are to use the entire surface of the stone when sharpening. This means the stone is likely to get dished out in the center after just a few sharpening sessions. One of the quickest and most effective methods I've found for flattening the surface is to "scrub" the stone using a sanding screen.

Sanding screens can be found at most home centers. They are generally used for smoothing drywall joint compound. I used a 120-grit screen taped to a flat surface for my waterstones. Before starting, draw a wavy pencil line on the bottom of the stone (inset photos). This helps track your progress. Using a circular motion, rub the stone over the flat screen. If needed, sprinkle the screen with water occasionally to keep it from clogging up. When the pencil lines are gone, you're done.



Mark a Line. Pencil lines help you track your progress as you sand the stone.

Scrub & Check. The pencil lines in the middle of the stone will often be the last to disappear.

Easy Edge Trimming

I prefer to put the edging on my plywood cabinets after they're all assembled and then trim it flush with a router. But I needed a way to support the router and be able to cut into the corners. This jig solves both problems.

The jig is easy to use. Just place the baseplate on the edging surface and feed it into the casing until the jig face contacts the surface of the workpiece. The little bit of wood left inside the corners can easily be cleaned up with a chisel.

It's constructed so the router bearing on a $\frac{1}{2}$ " flush-trim bit lines up with the two adjacent faces of the jig. The faces ride against the surface of the workpiece to keep the router stable. A dowel provides a handle for a good grip. And a notch under the top allows for the edging overhang.

To build it, I cut the pieces for the top, bottom, and faces from plywood. Next, cut a rabbet for the recesses on the faces and then glue and screw these parts together as shown. After cutting the router baseplate, mark and drill the mounting holes using your router as a template. Then mount the baseplate drilling the holes a little over-sized to allow for adjustment. The router is positioned so that the bit bearing is perfectly flush with the two jig faces.

The jig works equally well on the outside cabinet surfaces and prevents rounding off the corners, too.

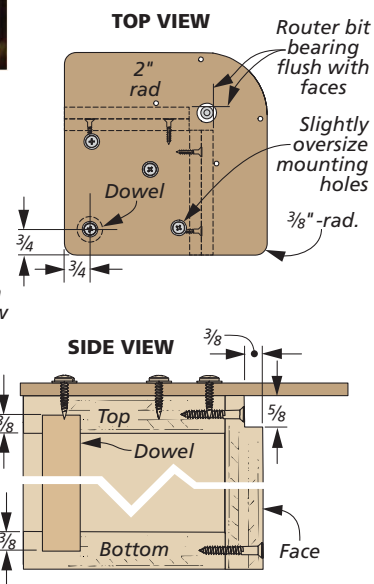
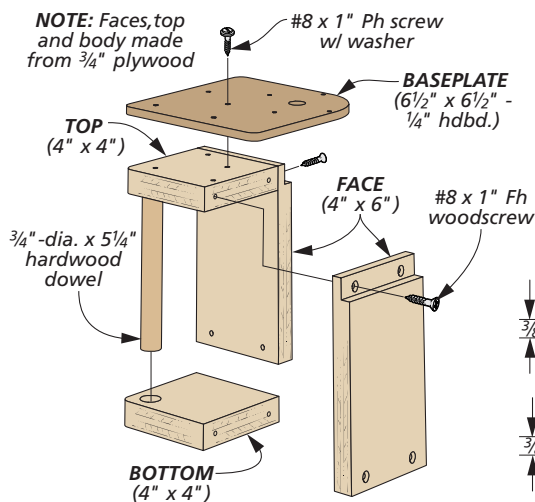

Adjustable Shop-Made Arc

Trying to bend a long, flexible strip and trace an arc at the same time can be tricky. To make it easier, I made an adjustable arc that can be locked into any curved shape I want. The arc is made from a strip of $\frac{1}{4}$ " pegboard (about 24" long), a nylon string, and a cord lock that I bought at a fabric store.

Easy Assembly. First, cut the nylon string to twice the length of the pegboard strip and tie it to one end (main photo). Next, slip one end of the string through the cord lock and then loop that same end through two holes in the opposite end of the strip. Finish up by feeding the string back through the cord lock (inset photo).

Adjust to Size. To change the size of the arc, simply move the looped end of the string into a different set of holes in the pegboard strip and adjust the cord lock.



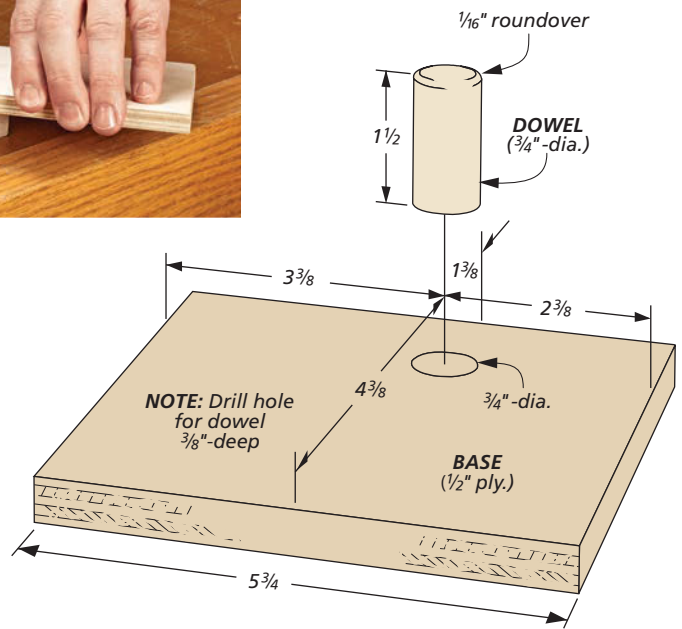

Adjustable Bench Dogs

The woodworking vise on my workbench doesn't have a quick-release feature. This can make it a little slow to adjust. To speed up the process when securing a workpiece using bench dogs, I came up with the simple accessory shown above. It allows me to hold a workpiece between it and a

unique bench dog inserted in the vise with a minimal amount of adjustment.

QUICK BUILD. This easy-to-adjust bench dog is nothing more than a square piece of plywood with a dowel inserted in a hole in the face of the piece. The key to the bench dog's adjustability is that the

dowel is placed in an offset position from center. This way, by simply rotating it in the dog hole from one edge to the next, the distance from the workpiece changes as well (4", 3", 2", 1"). This reduces the number of turns of the vise handle needed to secure the piece.

Cutting Thick Parts

I recently made a new workbench for my shop. The top consisted of several layers of MDF. After gluing the MDF panels together, I was faced with the task of trimming the ends to length. The benchtop was too big and heavy to run through the table saw. And it was too thick to make the cuts in one pass with a circular saw. Instead, I used this three-step process using my circular saw and router with a flush-trim bit installed.

Using a straightedge, I set the circular saw for its deepest cut. I then made the first cut to final length (Figure 1). Now, simply flip the workpiece over and reposition the straightedge so that the second cut is slightly longer than, but just overlaps, the first cut (Figure 2).

With your router, set a flush-trim bit so that the bearing rides against the cut you made on the first pass (Figure 3).

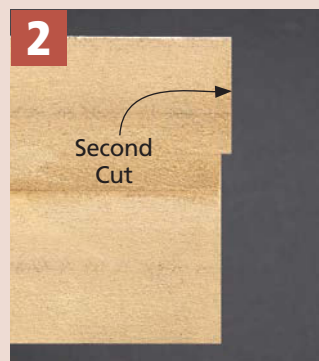

"Smart" Box Joint Jig Helper

Making box joints at the table saw calls for the use of a specialized box joint jig that often has a tall auxiliary fence to support the workpiece. The problem with having a tall fence is that it requires you to bend over the table saw after every pass, straining your neck and back to see the workpiece and index it over the key. This can really take its toll on your comfort when you're making multiple box joints.

To avoid this situation, I decided to let technology help me out by using my smartphone's camera to aid in positioning my workpiece. But I couldn't just set my phone on the table saw without some kind of support. So I made the cradle shown here to hold the phone. The cradle consists of a piece of plywood sandwiched between two pieces of hardboard and glued together. A couple of rare-earth magnets epoxied into holes in the bottom hold it in place. Since my phone is in a protective case, I sized the cradle accordingly.



NOTE: Size cradle to fit your smartphone case

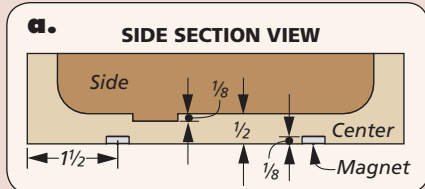
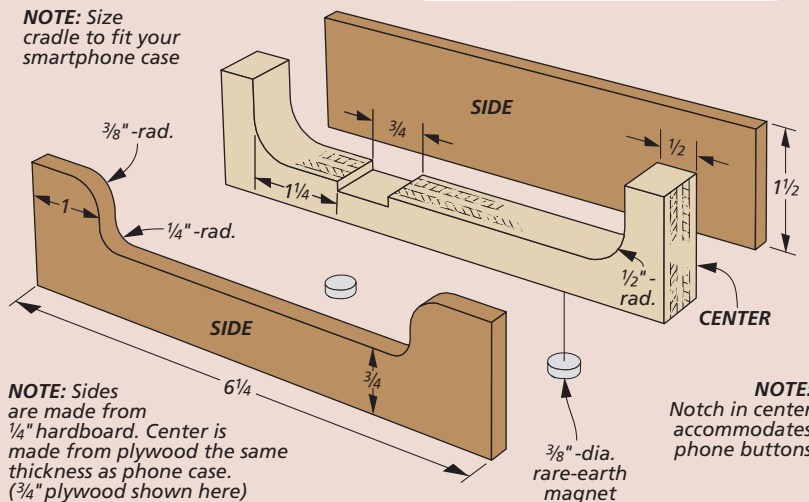

Flush-Trimming Edges

Adding extra-wide strips of hardwood to cover the edges of plywood panels is a pretty common practice, especially when making shelves. However, when it comes time to trim the edging flush, it can be tricky to balance the router on a narrow workpiece.

So whenever I'm making multiple project parts (like in the main photo above), I'll add some spacers between them to create a wide surface for the router to ride on. Just be sure to keep the top edges flush when you're adding the spacers and clamping everything together.



Router Leveling Jig

I work with a lot of rough-sawn lumber and live-edged tree slices, like the one shown above. Unfortunately, my planer is usually either too small to handle such large pieces, or it would cause too much tearout on endgrain. To get around this problem, I built this router leveling jig out of plywood. I sized my jig to accommodate the largest lumber slabs I use, but it could be made larger to suit your needs.

The leveling jig is nothing more than two router guides consisting of a base and a fence. The router guides are attached at either end to a couple of shim stacks. The shim stacks have a solid top and bottom, but the shims in the middle are slotted to allow them to be easily added or removed (detail 'a').

SIMPLE SETUP. To use the leveling jig, you'll need to place it, and the material being

leveled, on a flat surface. My workbench works fine for this. If your material isn't heavy enough to stay in position, you may need to use a non-slip pad to keep it from sliding on the workbench.

SHIM IT UP. The leveling jig is set in position over the workpiece. I place an equal number of shims in each shim stack until the router guides just clear the highest point of my workpiece. The four knobs are then tightened down.

With a large bowl and tray bit in the router, make a light pass along the fence. After each pass, slide the shim stacks over by just less than the diameter of the router bit and make another pass. It may be necessary to lower the bit and make several passes to completely flatten the surface.

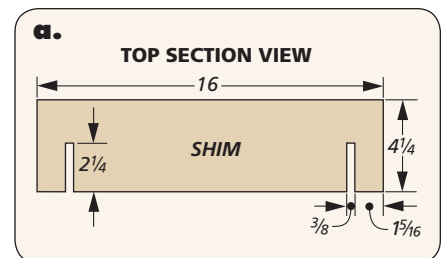
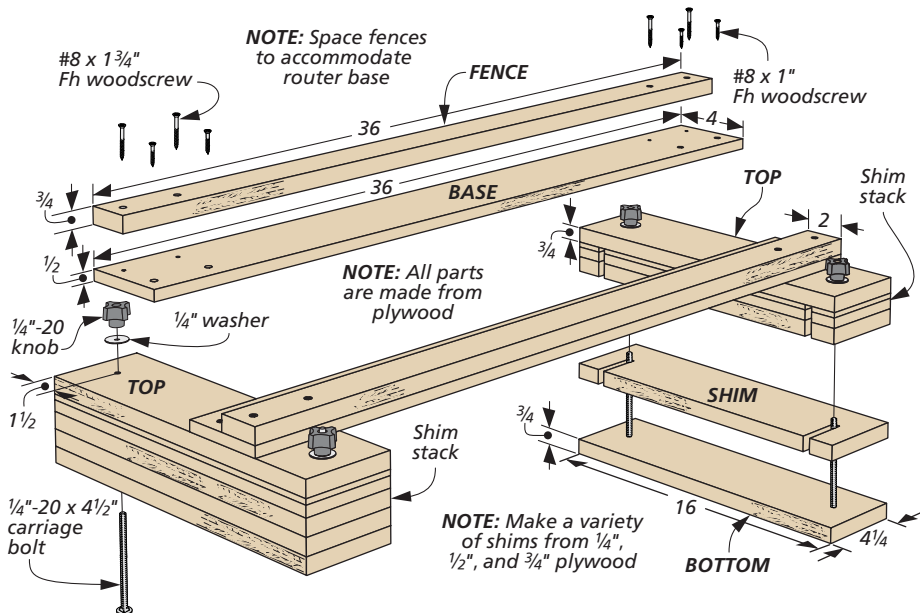

Cleaner Circle Cutting

Faced with the challenge of creating multiple wood discs for coasters, I needed a way to cut them out without making a center hole in the workpiece. I came up with a simple solution using a circle cutter and a scrap block.

To do it, adjust the drill bit on the circle cutter so it's higher than the depth of the cutting blade by the thickness of the workpiece, plus $\frac{1}{8}$ " , as shown in Figure 1.

Use a scrap block of wood that's at least the same thickness as the workpiece from which the circle is being cut and shorter diagonally than the diameter of the circle. Locate the block in the center of the circle and use double-sided tape to hold it in place. To keep the parts from moving as the blade makes the cut, clamp the workpiece to the drill press table. The block stabilizes the circle cutter without drilling into the workpiece blank. The disc is completely cut out when it starts to spin.

After removing the scrap block, you'll have a blank disc with no center hole. The same block can be used again to cut out multiple discs.

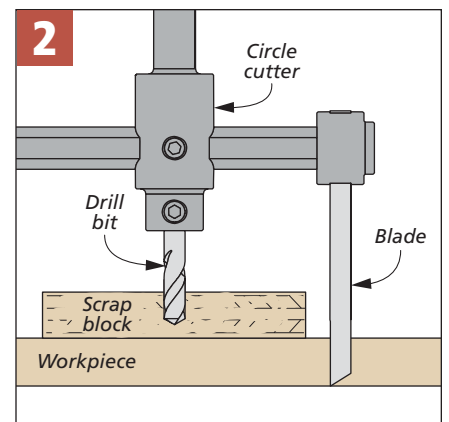
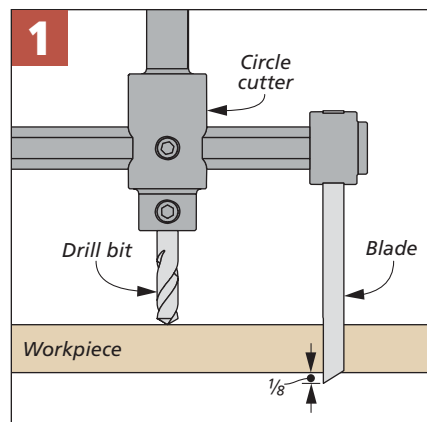

Curved Parts Sander

Sanding curved parts with power sanding equipment can be nearly impossible. Instead, I like to turn to hand sanding for smoothing these parts.

To aid in sanding these curvy pieces, I always keep one of these shop-made detail sanders on hand. I size my detail sanders for

use with 1" x 30" sanding belts, but other sizes will also work. The important thing to remember is the shape of the sander. They are designed so that when gripped near the curved end, the belt is properly tensioned to stay in place. I usually cut them a little oversize and sand them down to fit.

PATTERN

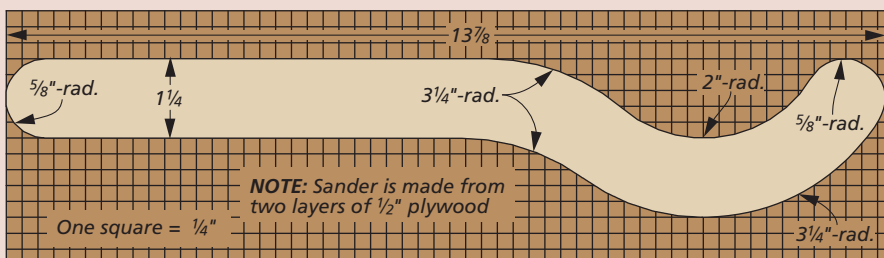



7 strategies for Perfect Panel Glueups

You can create smooth and seamless-looking panels from multiple boards using these simple steps.

Making a wide panel out of narrower boards is a fundamental woodworking skill. And while there's nothing wrong with using plywood in woodworking, there's something to be said for an heirloom piece of furniture that is crafted entirely from solid wood.

Gluing boards edge to edge seems simple in concept, but there's a bit more to it. These tips will help take you from good to great glueups.

CHOOSE WOOD CAREFULLY

With most panel glueups, the idea is to make the panel look like a single, continuous piece of wood. Achieving this goal requires finding boards with a good grain and color match. This is often as simple as setting boards side by side during the selection process, whether you're at the lumberyard or in the shop.

There's some debate in woodworking circles over whether or not it's necessary to alternate the direction of the growth rings on the ends of the boards that make up your panel. If the boards do decide to cup, this effect can be accentuated if the rings are all oriented in the same direction. So I try to switch up the direction of the rings for at least a couple of the boards in the panel.

GET THE THICKNESS RIGHT

Once you have the boards on hand for your panel, the next step in the technique is to head to the thickness planer. Here, you can go through the process of getting all the boards planed to the same thickness. There may be some more flattening to do once the panel is glued up, but this initial thicknessing of the workpieces will get you started off on the right foot.



Choose Wisely. Wavy, cathedral grain (upper boards) can be a lot more difficult to match up than tight, vertical grain (lower boards).

SIZE THE PARTS PROPERLY

The width of each board within a panel will vary from project to project. As a general rule, I try not to make my boards too narrow, as that can make it difficult to create a nice-looking panel. Generally, I try to stay in the 6"- to 8"-wide range to make it easy to surface the boards with my tools.

As for length, start with pieces 3" to 4" longer than the finished panel. This will give you some "fudge factor" during the glueup and allow you to trim it to final size easily afterward.

JOINT THE EDGES

You're just about ready to get out the glue and clamps. But first, there's one more step I always like to do before joining the boards. And that's a few passes over the jointer to dress all the edges that will be glued together. This ensures flat edges that will align perfectly.



Joint. Before you glue up a panel, a quick trip to the jointer to flatten and square up all the mating edges is a must.



On Edge. As you're preparing for glueup, stand the boards on edge and brush a thin layer of glue onto one edge of each joint. Then you can put the boards face down and get ready to apply the clamps.

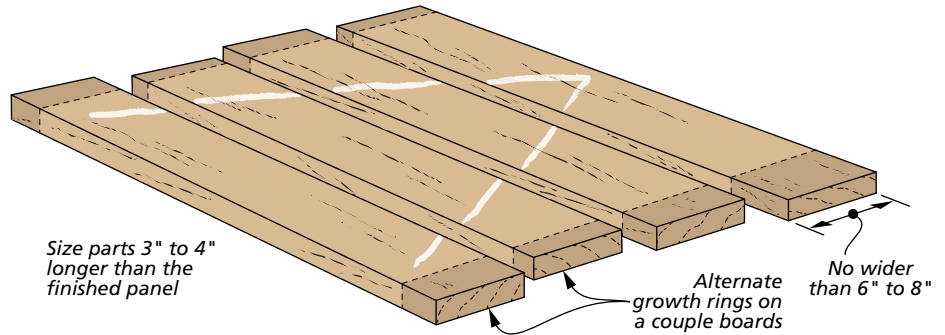

DO A DRY RUN

Your wood should now be ready to go together in a seamless, great-looking panel. Before getting out the glue, though, it's best to do a test run by clamping the panel together without any glue. This gives you a last chance for a visual inspection and an opportunity to reposition boards for a better grain flow if needed. Once you get it perfect, mark the top of the panel with a large "V" across all the boards. This is your guide for correctly aligning the boards during the actual glueup.

CLAMP IT RIGHT

It's finally time to get down to business. Gather all your needed supplies like glue, a brush, and wax paper, and set the clamps that will go beneath the panel in position. Have clamps to go over the panel at the ready. Now set the boards on edge, and brush a layer of glue onto one edge for each mating joint. Set the boards face down, and begin to add the clamps.

I like to assemble my panels by alternating the clamp position — one clamp under the panel, one over the panel, and

so on — to get even clamping pressure. As you tighten the clamps, make sure the lines of the "V" are close to being aligned. You can use a dead-blow mallet to coax boards into position, or you may even want to clamp the ends of the panel to keep them flat.

There will likely be some glue squeeze-out on the joint lines of your glueup. To remove this cleanly, wait about an hour, remove the clamps, and then scrape this partially set-up glue from the surface.

MULTIPLE GLUEUP APPROACH

For a small panel, you may be able to do just one glueup to complete the job. A different approach to larger panels, though, is to make smaller glued-up panels first. This lets you focus on one or two joints at a time, rather than several. Plus, you can put the smaller panels through your planer one more time before gluing them together into a larger panel.

Either way you approach the job, the basic concepts presented here remain the same. And the result will be a flat, smooth panel that's sure to look great in your completed project. **W**

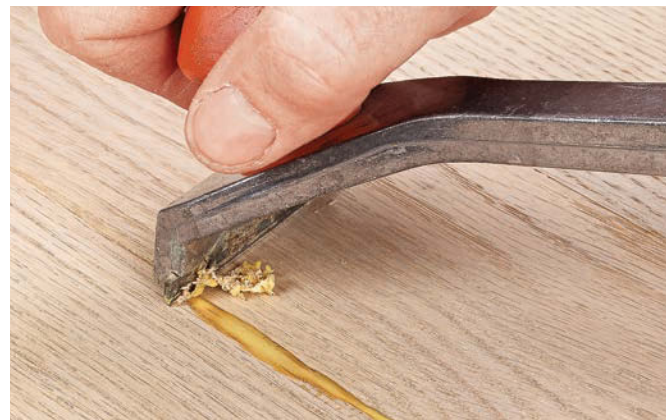

Scrape. There's bound to be some glue squeezeout after you clamp the panel together. Let this set up for about an hour, and then remove the partially dried beads of glue with a scraper.

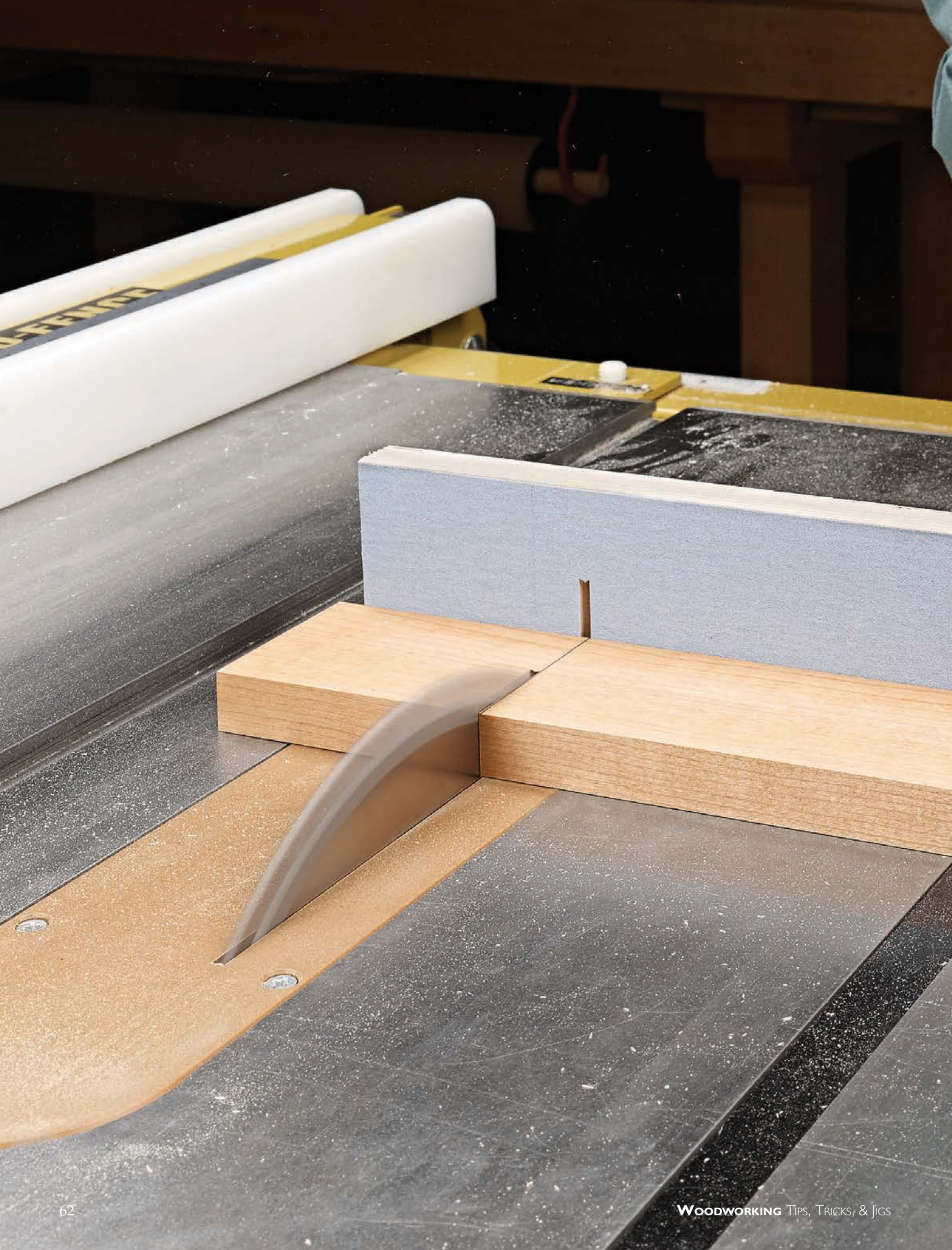



better layouts & Cuts

Accurate layouts and precision cuts are an early step in the process that ultimately leads to great-looking projects. Starting with rough lumber and going all the way to project-ready pieces, we have you covered.

TOOLS FOR PREPPING STOCK 64

SECRETS TO CLEANER CUTS 68

TIPS & TECHNIQUES 70

STRAIGHTEDGE GUIDES 78



tools for Prepping Stock

From rough lumber to project-ready workpieces, here are all the steps you'll need to form projects parts smoothly, consistently, and accurately.

Every great-looking project begins by choosing the right stock and then turning that material into precise project parts using the proper tools. And when it comes to the projects I build in my shop, I prefer to

start with rough lumber. Sure, it means more work jointing and planing, but I feel it's the best way to get great results.

To understand why, consider 4/4 stock as an example. In its rough state it's pretty much a full 1" thick, which means you have plenty of material to work with. On the other hand, 4/4 material that has been surfaced is often only about $13/16$ " thick. So if there's any cupping or bowing in these boards, you only have about $1/16$ " to work with before they're down to $3/4$ " thick (a fairly typical thickness for many project parts). Buying rough stock means I have more control over the final product.

BE CHOOSY. As you select lumber, be really picky. Almost every board will have some cup or bow. Small imperfections can be worked with. But if the material is badly warped, especially if it's twisted, it's best to put it right back on the stack and move on.

BUY EXTRA. Finally, I often buy at least 25% more material than a project

calls for. This might seem wasteful, but there will be knots and other defects to work around, a part or two to remake, and test pieces to cut. Plus, with extra material, you aren't as likely to be tempted to use pieces that are less than ideal.

There's one last thing I want to mention. Be sure to let the lumber acclimate to your shop before you start working with it (box on opposite page).

CUTTING TO ROUGH SIZE

After the lumber is ready, you don't want to just start cutting up boards. The first step to think about is layout.

THINK BIGGER PICTURE. As I lay out the individual workpieces, I think about the entire project. Right up front is the best time to select boards for highly visible areas like drawer fronts, the rails and stiles for door and case frames, and top panels that will always be visible. This ensures you'll choose the best material for those types of workpieces.

EFFICIENT USE OF STOCK. Depending on how the stock acclimates, you'll most likely

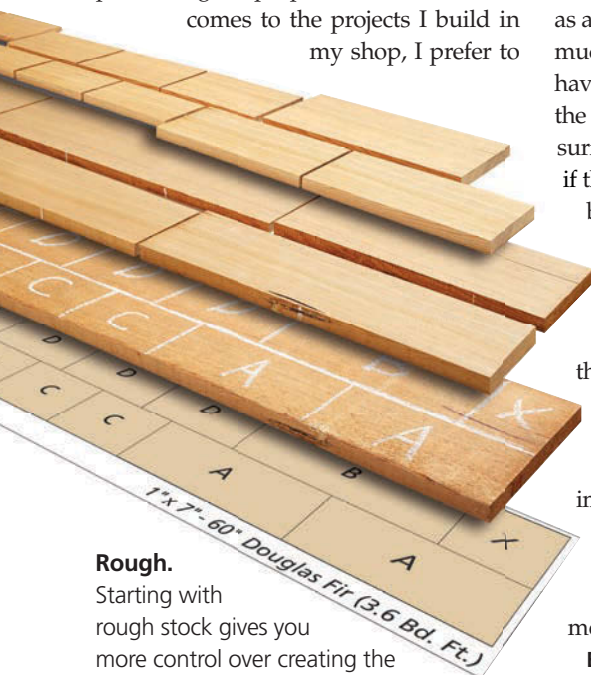

Rough.

Starting with rough stock gives you more control over creating the best workpieces for your project.

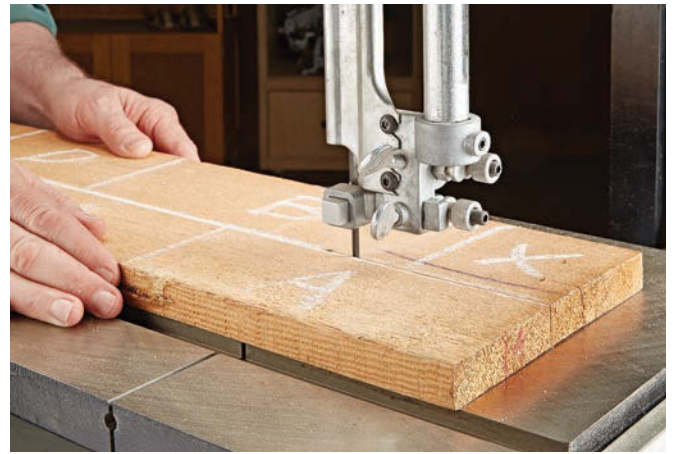
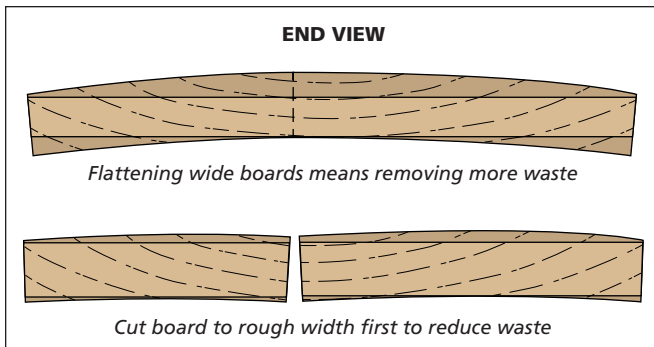

Prep. Cutting pieces to rough size (right photo) creates smaller, more manageable boards. Plus, you'll have less material to remove when it's time to flatten and straighten each piece (drawing above).

have to remove some material to get it flat. Jointing and planing across a long, wide board may mean removing a lot of material at the center and edges to create a flat reference face, as you can see in the wide board in the drawing above.

ROUGH CUTTING. So instead of working with a few long, wide boards, it actually makes more sense to cut them to rough size first. This is where I look at the layout of my pieces, and then rip and crosscut them into shorter, narrower pieces. This saves time, and stock, by reducing the amount of material that needs to be removed to create a flat surface, as in the two narrower boards in the drawing above.

CONSIDERATIONS. This up-front work often requires trade-offs. You want to rough cut the boards to avoid having to remove a lot of material. But that doesn't mean

you should cut out all the individual parts. For example, it isn't safe to work with really short, or narrow, pieces at the jointer or planer.

Instead, I find it best to rough size parts by type. This is where I like to keep all the drawers sides, fronts, and backs together in a few larger boards. Or I'll group parts that are all the same thickness in one rough-sized piece. This lets me focus on just a few larger pieces.

Second, I'll also keep similar width parts together. This way, once they're planed to thickness, I can joint and rip them to final width for consistency before cutting them to final length.

Sizing for Width. As you make your rough cuts, it's a good idea to leave individual parts or bigger groupings of parts extra wide ($\frac{1}{4}$ " to $\frac{1}{2}$ "). This provides

enough extra material to joint a face flat or straighten an edge safely.

ALLOWING FOR LENGTH. For overall length I leave parts or groupings of parts an extra 1" or 2" long. This provides enough material for squaring up the ends of a workpiece, or a set of similar parts, as you cut them to final length.

Some woodworkers often leave their parts an extra 4" to 5" long to allow for planer snipe (an extra deep cut on the ends of a workpiece). This way, they can simply cut off the "bad" part.

Personally, I think there are better ways to deal with planer snipe. You'll see my solution for taming snipe on the following pages as I use power tools to flatten and thickness the rough-cut stock, straighten edges, and ultimately, cut the parts I need for a project to final size.

How-To: Acclimate Your Lumber

Any time you bring new lumber into your shop, it's best to let it acclimate to its new home and adjust to the humidity in your shop. (I like to wait about a week.) It's likely you'll see some changes, such as a board checking on the end or a flat piece may end up cupping or bowing.

Proper Storage. To acclimate lumber, stack your stock systematically (stickering) to allow air to circulate evenly on all sides (near right photo). Unfortunately, that's not always the end of stock movement. If I find I'm not working with pieces in the near term, I make sure to set them on edge until they're needed, as in the far right photo.



Sticker. To let wood adjust to the moisture level in your shop, stack boards with small strips, called stickers, in between.

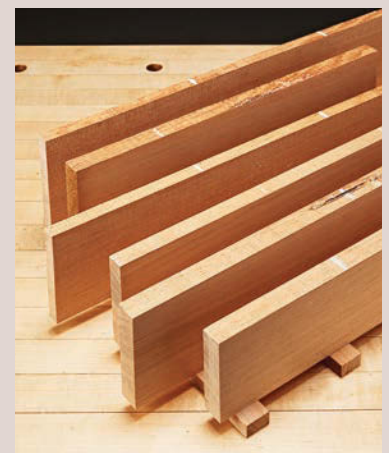

On Edge. For stock you won't be working with for a day or two, let air circulate by setting pieces on edge.

completing the Prep Work

Now that you have the pieces cut to rough size, the next series of steps will bring those rough pieces to final size. For this you'll use a trio of tools — the jointer, the planer, and the table saw.

FLATTEN ONE FACE

The first step when starting with rough stock is to flatten one face of each board. My tool of choice here is the jointer. Sure, you could use a hand plane, but if you have a lot of stock to flatten, a jointer will get you there more quickly.

JOINTER BASICS. With a jointer, the key is to feed the workpiece into the cutterhead so the edge grain runs with the cut. You can see what I mean in the photo and Figure 1 at right.

Chalk. A chalk squiggle across the face of the stock makes it easy to see when the workpiece is perfectly flat.



Plane. To avoid snipe, start a sacrificial scrap into the planer, followed immediately by a workpiece. After butting the workpieces end to end, complete the pass by butting a second sacrificial piece against the workpiece.



Joint First. Once you have your stock cut to rough size, the first step on each piece is to flatten one face. You'll want to make sure to keep in mind the grain direction (Figure 1), or any warping issues, like the cup shown in Figure 2, when you pass it over the jointer.

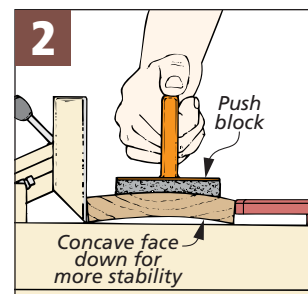
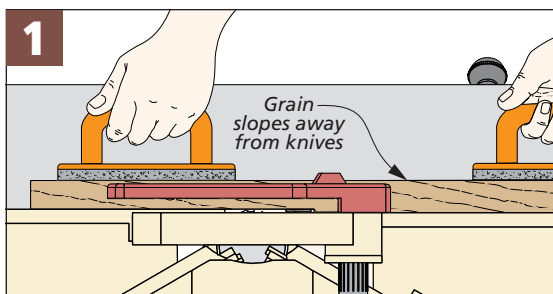

Figure 2 above. This ensures that there are two points of contact with the bed to keep the workpiece from rocking.

LIGHT PASSES. Jointing the face of a wide board requires a firm grip and a good push block (or two). And don't try to flatten the board in a single pass. Instead, set the jointer for a light cut, $\frac{1}{32}$ " or less. A light cut is easier on the jointer and results in a smoother cut overall. Since it can be a challenge to see your progress, I scribe lines across the face of the workpiece with some chalk, as in the upper left margin photo.

PLANE TO THICKNESS

After jointing one face flat, the board is ready to run through the thickness planer. A planer does two things. First, it makes the second face flat and parallel to the first. And second, it reduces the workpiece to its final thickness.

PLANER BASICS. Feeding a board through the planer is a pretty simple task. After all, the feed rollers of the planer do most of the work. Here again, it's best to take light passes ($\frac{1}{32}$ " or so) and take care to feed the pieces so the cutterhead is cutting with the grain.

PLANE BOTH FACES. If there's more thickness planing to do after both faces are flat and parallel, be sure to flip the workpiece between passes. Planing the same amount from each face will help minimize any cupping or bowing that may happen once the freshly planed wood is exposed to the air.

STRAIGHTEN AN EDGE

Now that both faces are flat and parallel, you can turn your attention to the edges. And for that I use two separate tools.

Back to the Jointer. The first edge is straightened and squared to one of the faces at the jointer. Be sure the fence is 90° to the table and then joint the concave edge until you "hear" the jointer cutting along the entire length of the piece.

To be absolutely sure you're jointing along the entire edge, you can squiggle



Joint Again. With the rough stock planed to final thickness, you can head back to the jointer to create one smooth, straight edge.

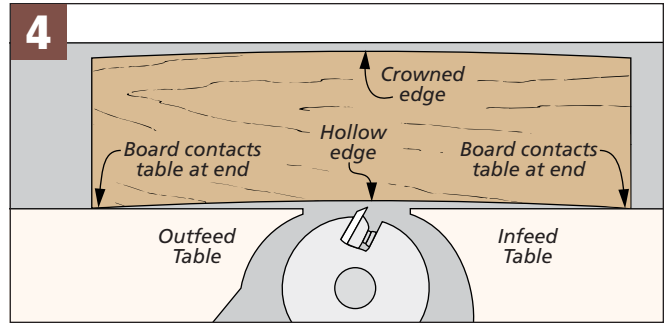
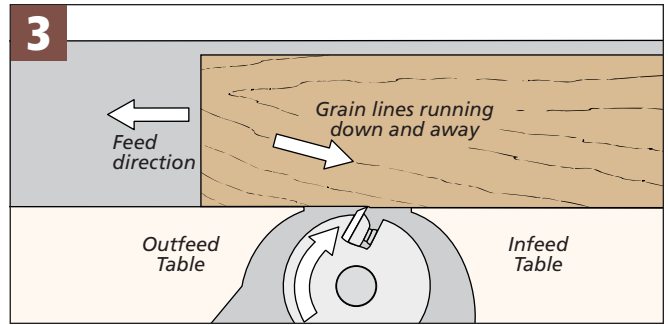

some chalk lines along it just like you did on the face of the workpieces.

Just like before when you were jointing the face, cut with the grain, as detailed in Figure 3. And if the board is bowed along the edge, keep it facing down, as shown in Figure 4.

Many boards (especially longer pieces) have grain that changes direction along the edge. The solution here is to slow down when you get to the point where the grain direction changes. This way, the knives of the jointer will be taking smaller bites, and you'll be less likely to end up with any chipout.

CUT TO FINAL SIZE

To get the second edge straight and parallel to the first, head over to the table saw. Make sure the jointed edge is against the fence (left photo below) and rip the board so it's slightly wider ($\frac{1}{32}$ ") than the final width. Then you can make a final pass at the jointer to remove any blade or burn marks.

All that's left at this point is to cut the square and surfaced stock to final length. Here's where I make my last stop at the table saw. Using an auxiliary fence attached to my miter gauge, I can quickly make the crosscuts. If I have a

number of workpieces that need to be cut to the same length, I like to use a stop block attached to the auxiliary fence to ensure they all end up the exact same length (right photo below).

FINAL THOUGHTS. With this process, you're sure to end up with workpieces that are flat, straight, square, and ready for any needed shaping or joinery. But sometimes, a piece I had prepped straight and flat the day before will warp enough overnight that I can't use it. If that happens, don't be afraid to start over on a new piece. In the end, it'll save time and frustration **W**



Rip. To get the second edge straight and parallel with the first, rip it a hair overwidth ($\frac{1}{32}$ ") at the table saw. This way, you can make a single pass at the jointer to remove any saw or burn marks.



Crosscut. All that's left now is to cut the pieces to final length at the table saw. For workpieces that need to be identical length, use a stop block clamped to an auxiliary miter gauge fence.



secrets to Cleaner Cuts

Glass-smooth, tearout-free cuts on the table saw are within reach with just a few simple additions.

Once it's tuned up properly, any table saw can handle the core functions of ripping, crosscutting, and forming dados and grooves. Of course, there's a big difference between simply performing these operations and ending up with glass-smooth, show-quality workpieces after the cut is complete.

The secret to achieving flawless cuts, rather than parts that need a lot of cleanup afterward, is being mindful of a few simple table saw setup tips prior to getting started. The good news is that with many of these steps, you only have to go through the process once before you can

get to work creating your project parts. After that, your table saw will be ready to go for quite a few projects to come.

FOCUS ON THE BLADE. Getting flawless cuts, of course, starts with using the right table saw blade. And while you might think that means using a 24-tooth rip blade for all your rip cuts and an 80-tooth crosscut blade for crosscuts, that's actually not always the case.

If you invest your money in a high-quality combination or general-purpose blade, it should handle both types of cuts well. As you can see below, these blades vary in style. The one on the left,

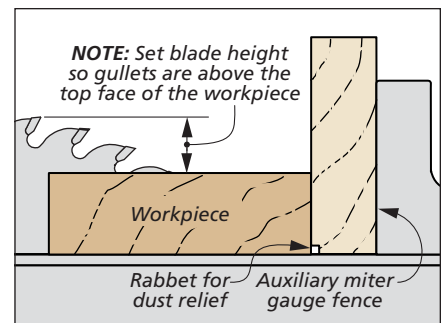

for example, is a true combination blade with 50 teeth, while the one on the right is a general-purpose blade with 40 teeth. However, as long as the teeth feature an "alternating top bevel" (ATB), where the top angle of one tooth is opposite the next, then the cuts tend to be comparable.

Another issue when it comes to clean cuts is the height at which to set the blade. If you raise the blade too high, the teeth are positioned in a manner that they're

A dull, dirty blade can leave burn marks on workpieces



A new, sharp blade produces a glass-smooth cut



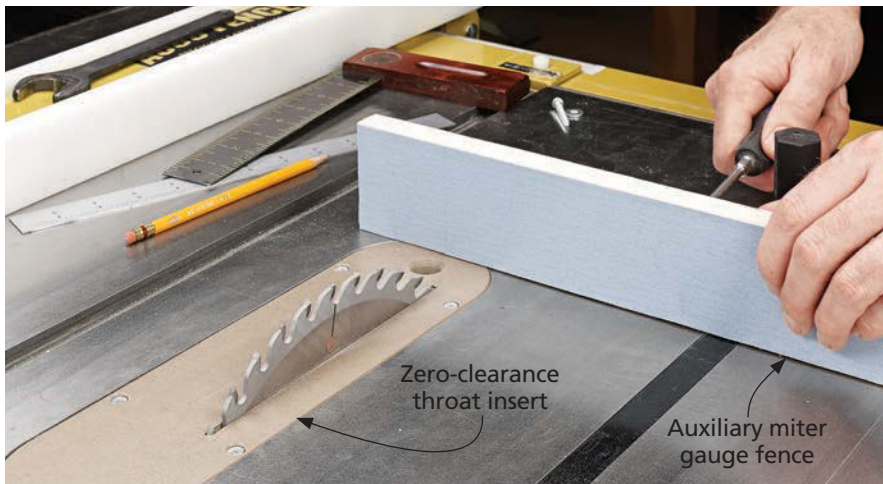

Easy Table Saw Add-Ons. A zero-clearance insert and auxiliary miter fence are the two critical accessories to achieving smooth table saw crosscuts.

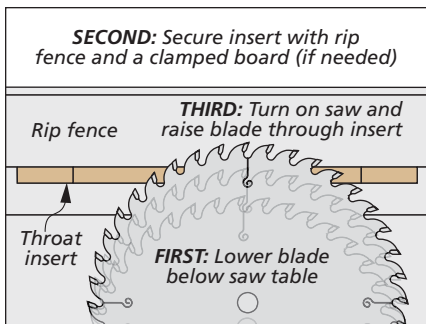

chopping at the wood, resulting in a chattered cut. Too low, and clearing sawdust from the kerf becomes a concern.

For best results, I aim for the “sweet spot” of around $\frac{3}{4}$ " above the workpiece. This positions the teeth so they’re shaving or shearing at the wood as they pass through the top face of the workpiece (refer to the drawing on the previous page). It also locates the gullets, or spaces between the teeth, above the board to allow for sawdust and chip clearance.

After awhile, it may be time to clean the blade or have it resharpened. Knowing when requires visually inspecting the blade and the results of your cuts. If it takes more effort to make a cut, the cut isn’t as clean as it used to be, or the teeth are covered with pitch or resin, then it might be time for a cleaning or resharpening. The lower left blade on the previous page is a good example.

ADD AN INSERT. The plate that surrounds the blade in your table saw is known as a throat insert. And the insert that came with your saw likely has a long, wide slot to accommodate different blades or

cutting angles. In reality, having extra space around the blade creates a potential for a chipped or “fuzzy” cut as the blade exits the bottom face of the board.

To eliminate this, a zero-clearance insert is a must. You can purchase inserts that fit your saw, or make your own. I like to purchase a few and then prep them for common cuts I make, such as different widths of dado blades.

To prepare a zero-clearance insert for making cuts, lower the saw blade the way down into the saw cabinet. Then “lock” the insert in place by setting the rip fence over one edge of the insert, and clamping a board across the other edge of the insert. Just make sure both

are clear of the cutting path of the blade. Now turn on the saw, and slowly raise the blade through the insert (drawing at lower left). Then you’re ready to make clean cuts with the workpiece fully supported from underneath.

BACK UP THE CUT. In addition to the bottom of the workpiece, another area where chipout or tearout can occur is where the blade exits the back of the cut when crosscutting. Your protection here should come in the form of an auxiliary miter gauge fence.

The auxiliary fence doesn’t need to be fancy. Just a flat, stable piece of plywood screwed to the saw’s miter gauge will do. I also like to put adhesive-backed sandpaper on the face of the fence to prevent the workpiece from shifting during the cut.

As you can see in the main photo on the previous page, you’ll want to position the fence so that it extends a few inches beyond the cutting path of the blade. This fully supports the area being cut, and also enables the fence to push the cutoff past the spinning blade. As an added bonus, the kerf produced by the blade lets you easily position future workpieces in order to cut them to length accurately.

PUTTING IT ALL TOGETHER. It doesn’t require much effort to get your table saw ready to cut parts so clean they’re almost project-ready. Run through this checklist before you start work on your next project, and you’ll be sure to notice the difference. **W**

Shop Tip: The Right Time to Tape



Extra Insurance. Masking tape placed on the cutline holds wood fibers in place to produce tearout-free cuts.

When I’m working with cabinet-grade plywood or cutting small parts where clean results are critical, I’ll add one extra step to my “clean cut” checklist. And that’s taping the cutline with a strip of painter’s masking tape.

While the precautions listed in this article are sufficient for most of my cuts, the tape helps secure the fibers around the cutline for the cleanest results possible. Today’s masking tapes also peel off cleanly without leaving residue or pulling up wood fibers around the cut.



Push Block Holder

When using the table saw, there's often an awkward moment when I need to pick up a push block midway through a cut to complete the process safely. It seems that no matter how close I position the push block, I occasionally fumble with it when it's lying flat on the saw table. To solve this problem, I built

this push block holder that sits right on top of my rip fence and holds my push block upright where it's easy to grab. It's simply a plywood cradle with a couple rare-earth magnets recessed in the base to hold it in place. Now, my push block is always at the ready without an uncomfortable or unsafe reach.

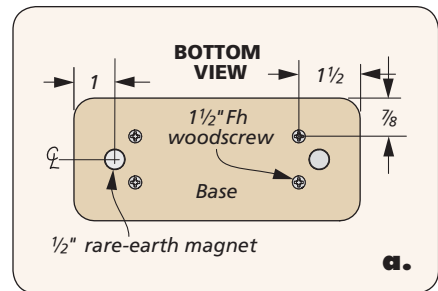

NOTE: Size base to fit on rip fence

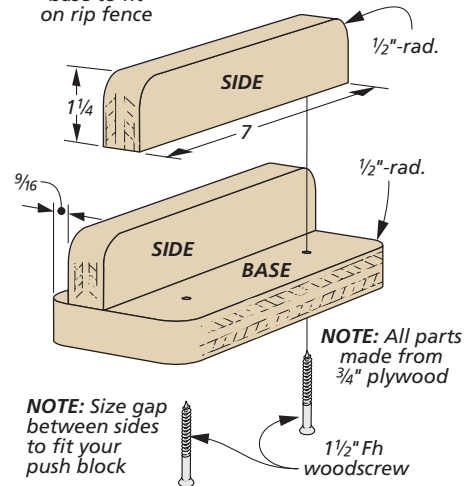

Quick Tip



CENTER-FINDER TOY

I found a clever way to make a center-finder tool using some of my child's toys. I simply connected a few *Lego* pieces like the ones shown above to one another to form a parallelogram. With a pencil in one end piece, the center-finder adjusts for varying thicknesses of lumber.

Sheet Goods Helper

When it comes to breaking down sheet goods, there's certainly no shortage of ways to complete the task. But I was looking for a way that would utilize my *Workmate* bench without cutting into the worksurface. What I devised is the setup you see above.

This method uses a C-channel made from a 2x6 for the base and some

plywood scraps that act as risers. The risers are attached to the base with screws. I sized my pieces so they're a couple feet longer than my *Workmate*.

Using It. With the C-channel clamped in the *Workmate*, position the cut line so it straddles the opening and make the cut. A sawhorse or two provide additional support.



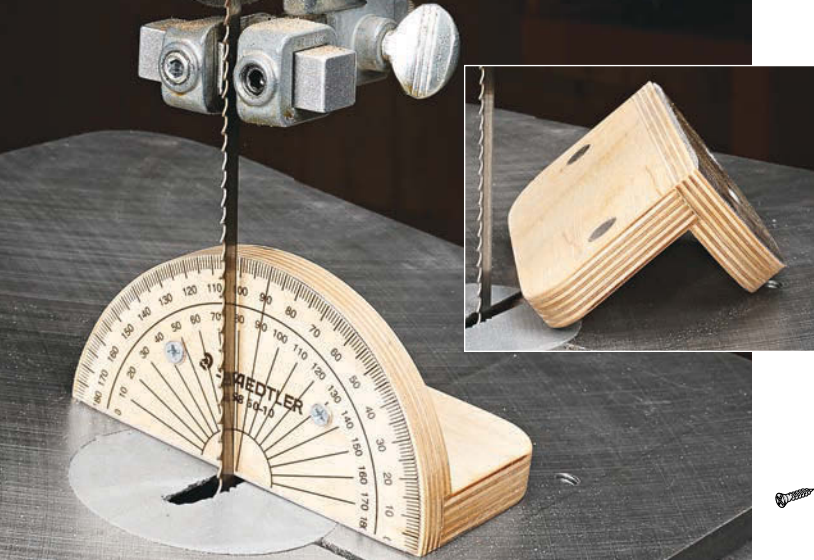

NOTE: Drill countersunk holes in protractor before screwing to upright

NOTE: Upright and base are made from 1/2" plywood

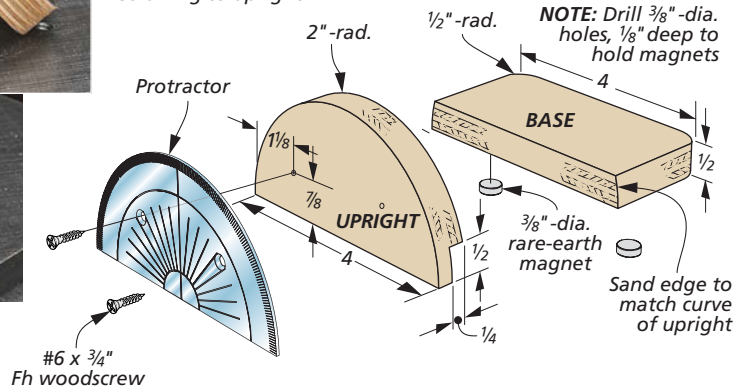

Band Saw Table Gauge

Trying to tilt the table on a band saw using the gauge underneath the table can be challenging to say the least. And holding a triangle or bevel gauge on the table surface while simultaneously tightening the table knobs is not much easier. So I designed the tilt gauge shown above using an inexpensive drafting protractor from an office store.

This gauge is simply two pieces of plywood that are rabbeted to fit together at 90°. I shaped the upright piece to match the curve of the protractor before I attached the protractor to it with screws. A couple of rare-earth magnets epoxied into the base piece keep my hands free to tighten the table knobs after setting the gauge.

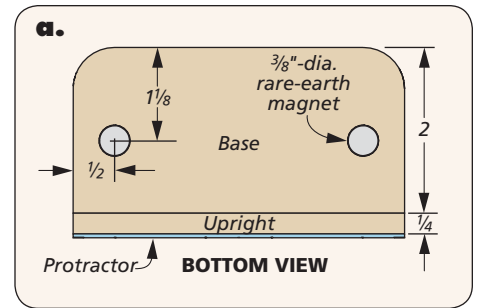

Easy Spline Trimming

Recently I made 10 keepsake boxes that featured mitered corners reinforced with splines. Normally I would reach for a hand saw to trim the splines flush with the sides of the box. But the prospect of trimming 120 splines sent me searching for a quicker method. The solution I arrived at was a simple "notched" fence to slightly recess my band saw blade.

The fence should be low enough to fit under the lowest spline. In my case, a scrap piece of plywood worked perfectly. Make the notch wide enough to accommodate the width of the band saw blade (inset photo). Then clamp the fence to the table and trim the splines nearly flush before sanding them smooth.

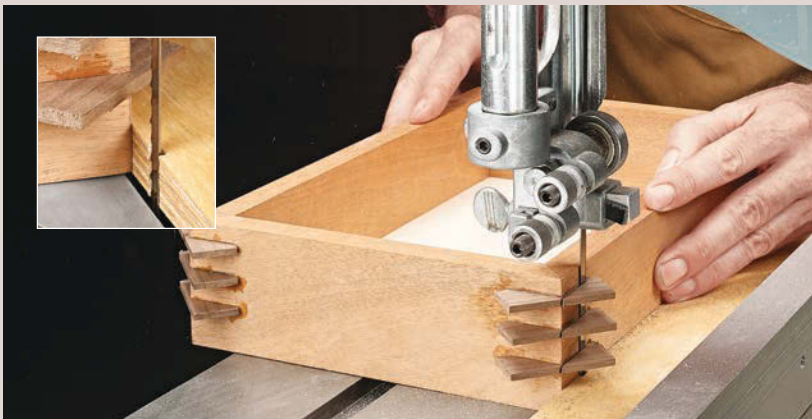

Quick Tip



SET HONING GUIDE ANGLE

I've always found it cumbersome to get my honing guide set at the correct angle when sharpening my chisels or plane blades. Then it dawned on me that my digital protractor might provide an easier solution. To set the angle properly, I use a spring clamp to hold my protractor steady. This frees up both of my hands in order to tighten the screws on the honing guide.

Hot Glue for Edging Lumber

For many of my woodworking projects, I use short pieces of rough-sawn stock. Some of the edges are too uneven to safely run them through my jointer to true one edge. Instead, I devised the following technique that allows me to cut one straight edge using my table saw.

Simple Setup. Start by placing the rough-sawn piece against the rip fence. Position the fence to get the best use out of the board and lock it down.

I then place a few dabs of hot glue down the face of the board closest to the fence to attach a narrow, straight-edged piece of plywood. The plywood should overlap the workpiece and ride against the fence. When the glue hardens, run the pieces through the table saw to get a perfect straight edge on the board. The dried glue scrapes off easily.

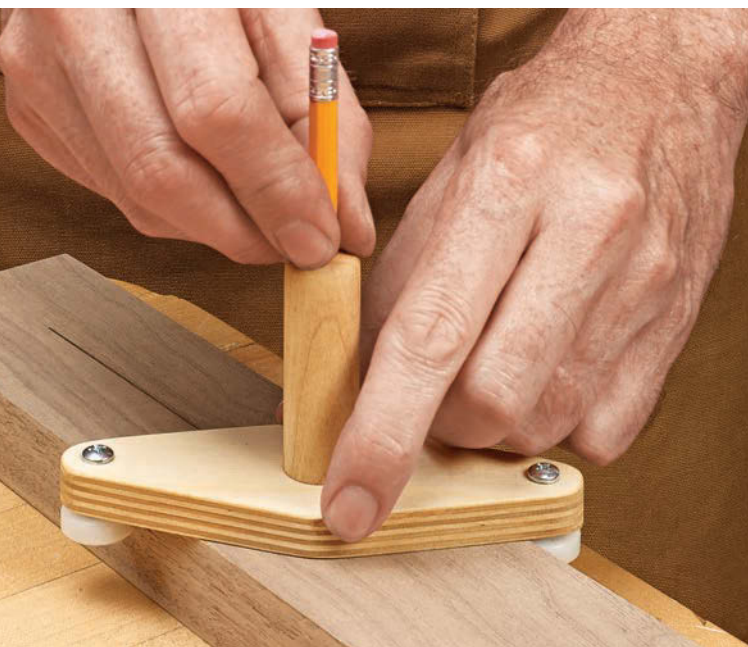

Rolling Center Finder

Over the years, I've seen (and used) many different kinds of center-finding tools. Whether they were shop-made or manufactured, they all had a tendency to use dowels, steel pins, or some other type of material that would drag along the outside edges of a workpiece. Recently, while shopping for some shower door replacement parts, I was struck with the perfect idea for an improved center-finding tool.

NYLON WHEELS. At the heart of this design is a pair of inexpensive sliding shower door replacement rollers. The rollers glide smoothly along the edge of a workpiece. After cutting a piece to size for the base, take your time in laying out the hole locations for the screws that secure the rollers, as well as the hole for the handle. The rollers need to be the exact same distance from the center hole in the base. With the parts completed, simply glue the handle in place and attach the rollers with screws, and this tool is ready to put to use.

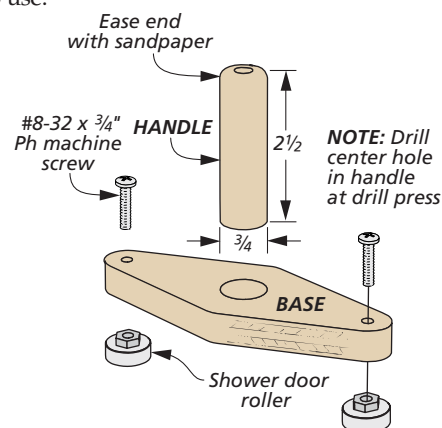
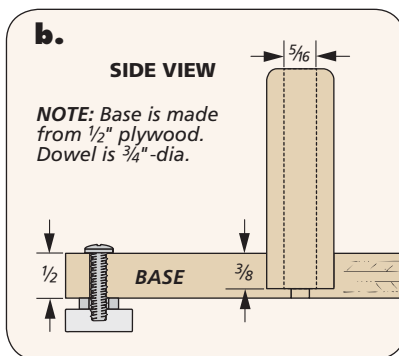
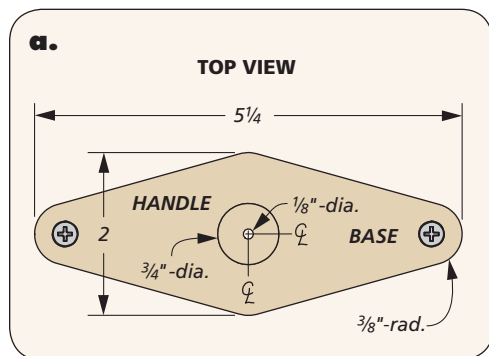

Sawhorse Flip Stops

One of the cardinal rules of using a circular saw is to make sure your board is secure before making a cut. But to be honest, I don't always follow that rule. So instead of concentrating on the cut, I end up trying to keep the board from sliding across the sawhorse. To solve this problem, I installed two flip stops on each of my sawhorses. The stops hold a board in place without having to fiddle with clamps.

EASY CONSTRUCTION. Each flip stop consists of two wood blocks. The flip stop itself can be pivoted up when you want to use it (main photo). A cleat mounted underneath holds the flip stop in the upright position. Before attaching the two blocks, it's a good idea to bevel the end of the flip stop. This makes for a handy finger recess.

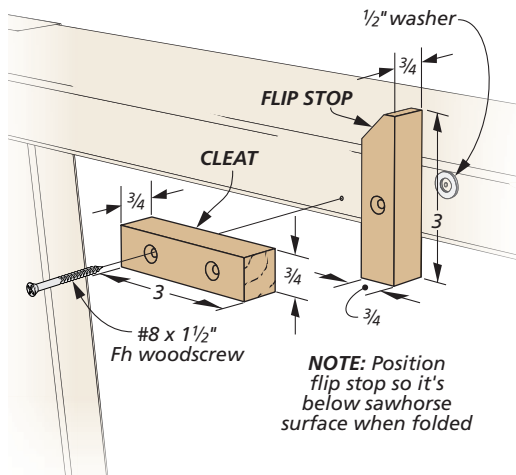

Subdividing Circles

On a recent trip through the local grocery store, I found this handy item at right, a tuna and veggie press and strainer.

The larger, outside disc has 36 evenly-spaced holes around its outside edge and a second set of holes offset half-way between the first set. This allows you to divide a circle into 5° segments easily. Or in my case, assist in laying out the number positions on the wood face of a clock I was building.

Simply mark opposite holes to find the exact center. You can then count over in 10° increments and mark the positions you need. In the case of my clock, every 30° was marked.

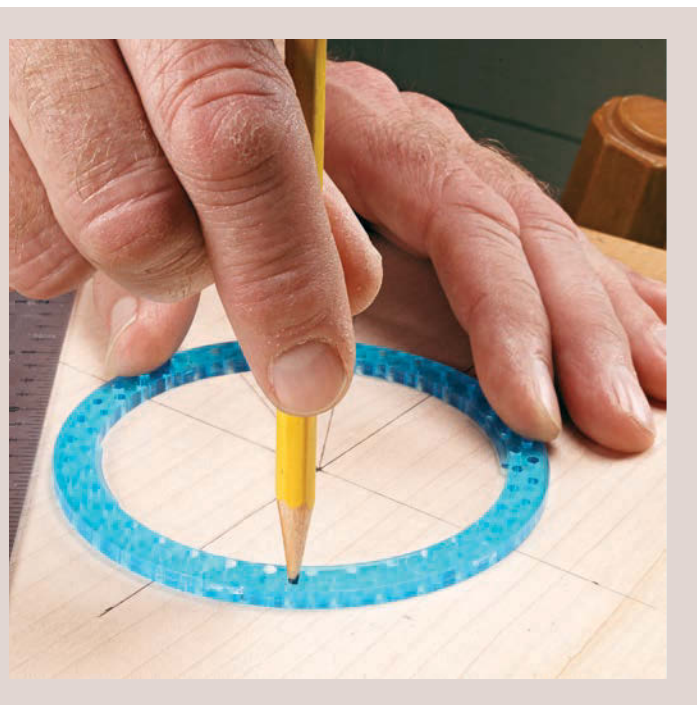
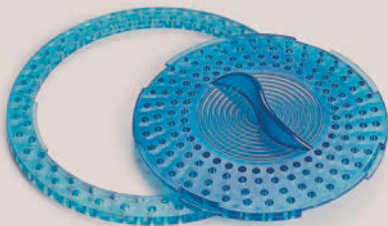

Outrigger Miter Saw

Using your hand to hold a workpiece against the fence of a miter saw can be a dangerous proposition. Especially if the workpiece is small or needs to be held at an angle (like the crown molding shown at left). To assist in situations like these, I designed this dual outrigger clamping system to use on my miter saw.

TWO COMPONENTS. This clamping system consists of two main components. The riser assemblies raise the clamps up to the level of the miter saw table. They're attached to the workbench with screws. The other parts consist of clamp assemblies that hold the workpiece against the fence. Each one has a tall fence on one side with a strip of adhesive-backed sandpaper on its face. The two slots allow for different clamp placements (photo below). A threaded rod and knob secures the clamp to the riser assembly.

CUSTOMIZABLE DESIGN. This clamping system can be configured to fit other miter saws. For instance, the riser assemblies can be made taller or shorter by changing the dimension of the uprights. Or, the risers may work better to the side of the saw base, rather than in front.

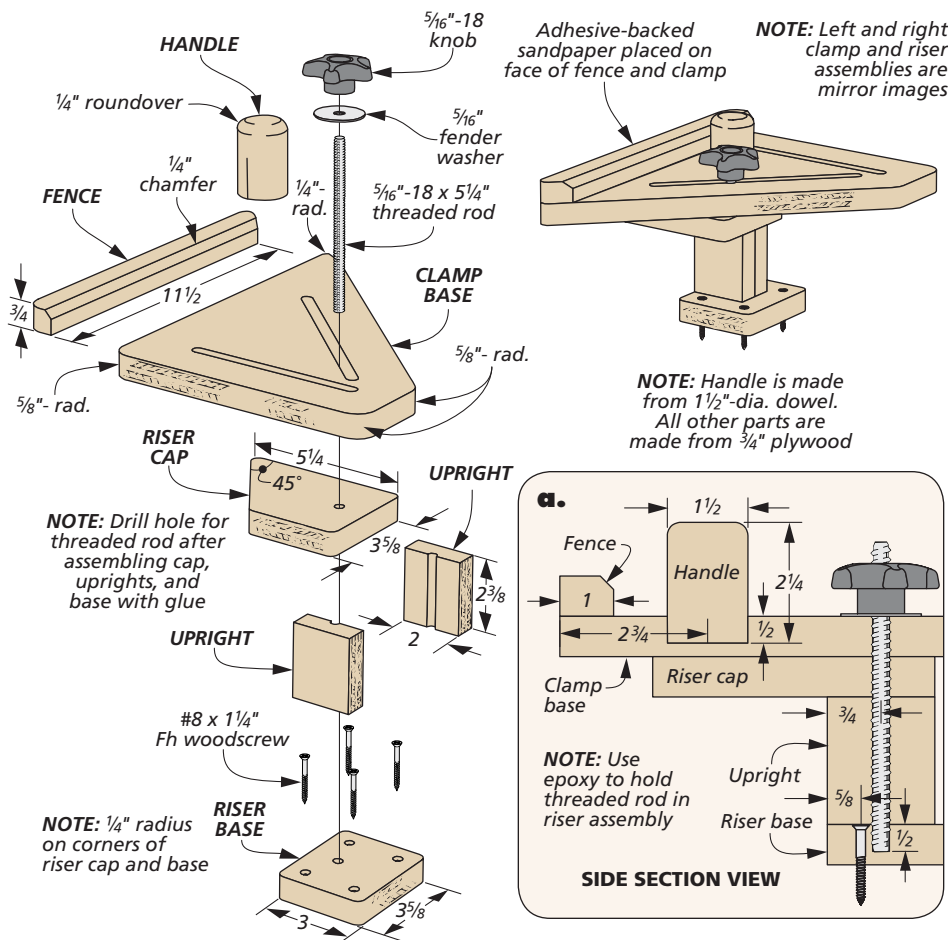
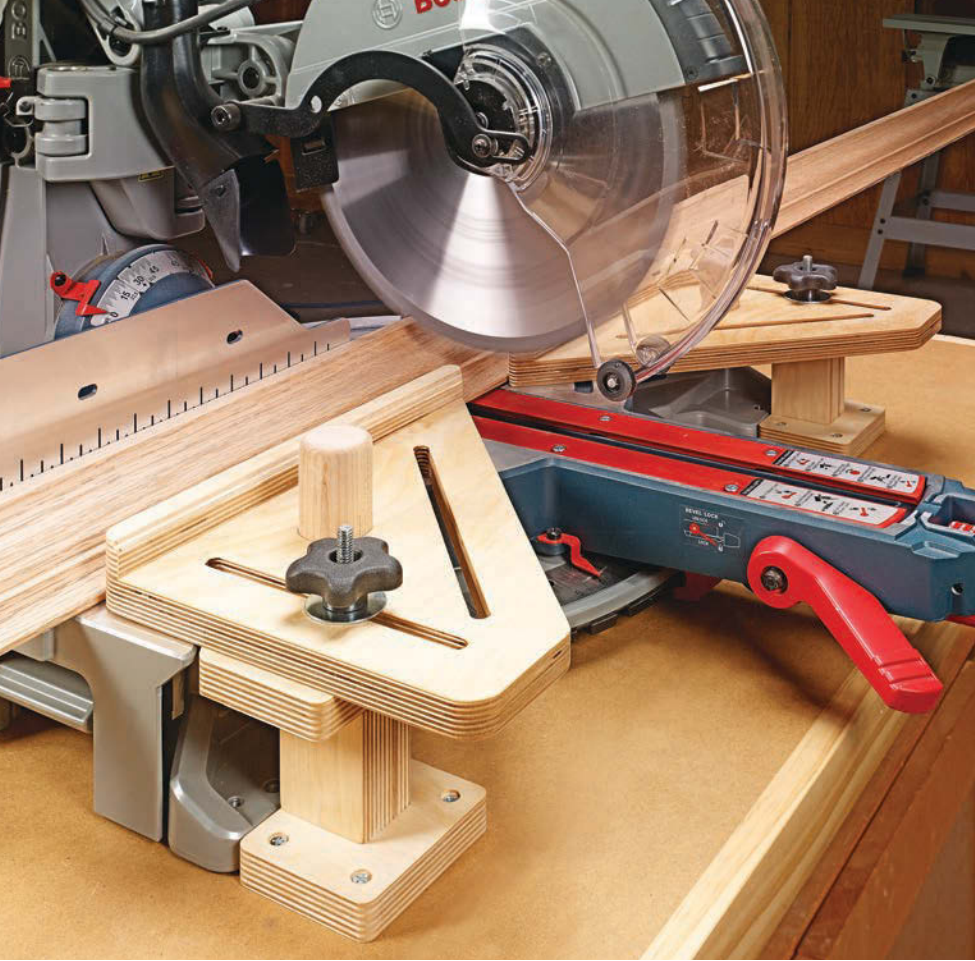

Angles. For blade clearance, position the clamp base with the threaded rod through the 45° slot when making angled cuts.

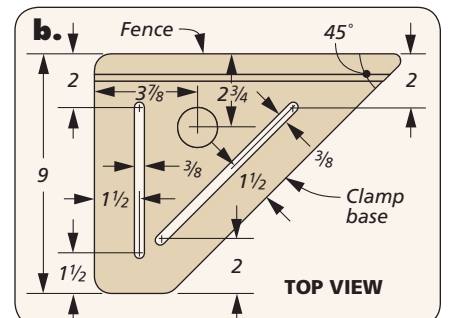
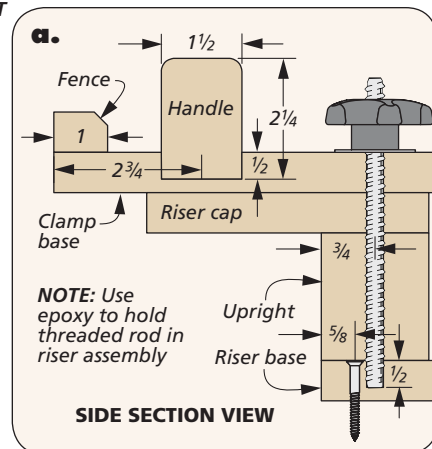

Super Paper

Ok, so it's not paper, but over the years I have found many uses for this versatile material known as High Impact Polystyrene, or HIPS. It's thin and flexible, yet stiff and dimensionally stable. It's tear resistant, waterproof, and can be marked with a pen or pencil. Plus, it's easy to cut with scissors or a knife. Best of all, HIPS is sold in large sheets that are relatively inexpensive.

It's simple to make full-size patterns of curved project parts. The patterns can be rolled up for transport, or stored flat. Because of HIPS low cost, it's an attractive material for use in one-time applications. A small piece can be edged with pinking shears to make a glue spreader. Another can be used to mix small amounts of epoxy. Pick up this versatile material at a hobby store and you're sure to find several uses of your own.

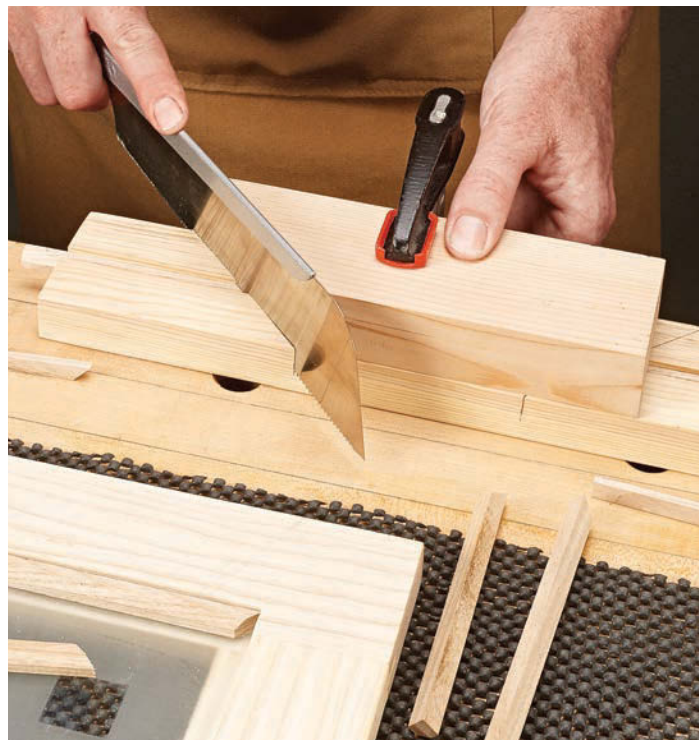
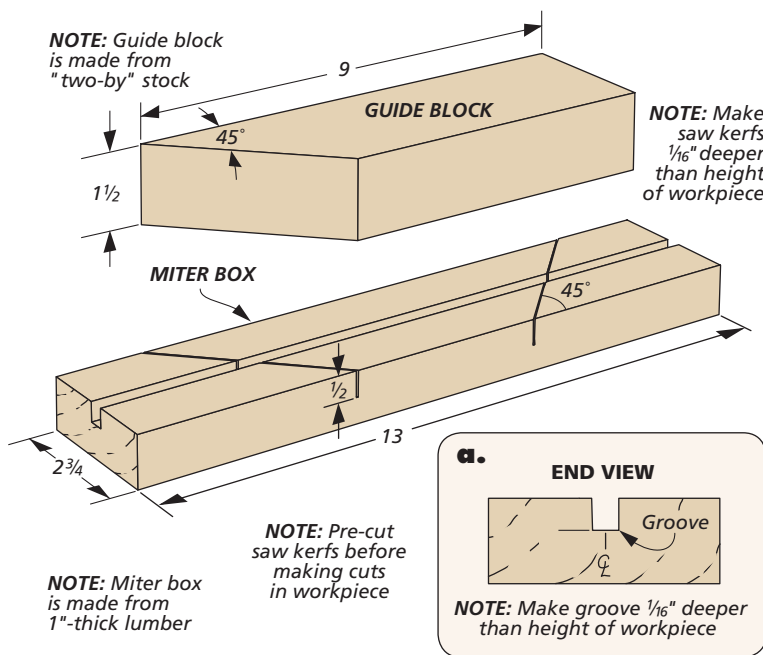
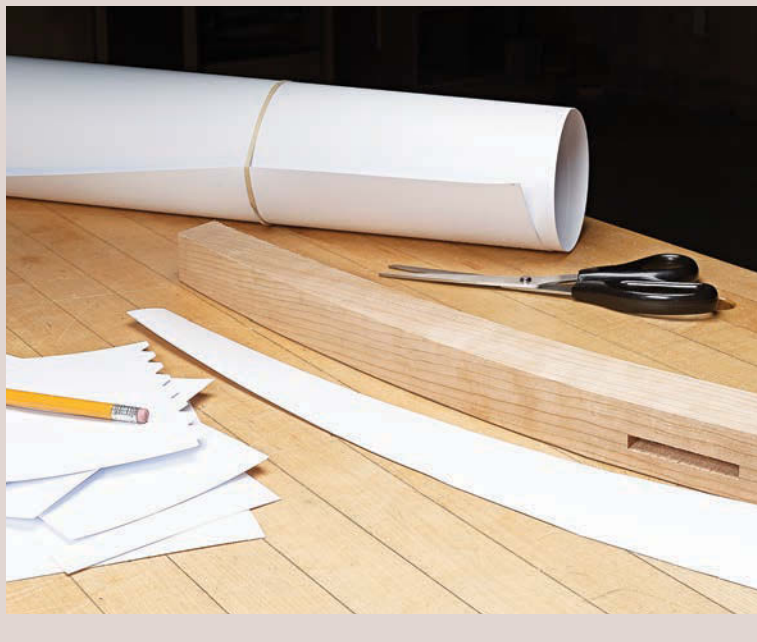

Five-Minute Miter Box

When cutting miters on small strips of molding or glass stop, a power miter saw is really overkill. It tends to splinter the wood and can turn those tiny pieces into dangerous projectiles. To avoid this problem, I made my own small-piece miter box and used a hand saw to cut the miters (photo, above right).

The miter box is simply a 1"-thick piece of scrap lumber with a groove cut down the center to hold the molding strip.

The groove is a bit deeper than the thickness of the strip. This way, the strip rests below the surface of the box, keeping the saw aligned as you begin cutting. And since this miter box is so simple and inexpensive to build, it's easy to make several customized boxes as you need them for different sizes of glass stop and molding.

The box has opposing 45° kerfs to cut both ends of the strip. To make these

kerfs, mark their locations with a combination square. Then tape a mitered guide block (also made from a piece of scrap lumber) on the cut line with double-sided tape and cut the kerfs with a pull saw, as shown in the photo above.

When cutting the miters, the idea is to end up with a strip slightly longer (about 1/32") than needed. Then use a block plane or sanding block to tune them to final size.



Storage. The screw eyes in the ends of the bench hooks provide a convenient way to hang them on pegboard for storage.

Bench Hooks

Usually a hold-down is used to clamp a workpiece flat against a benchtop. That's okay for some work. But if you're sawing, drilling, or routing, it often requires clamping the piece so that it overhangs the edge of the workbench. As a result, it's not adequately supported, which makes for a rough, less-than-accurate cut.

CREATIVE SOLUTION. A more versatile solution is to make a set of bench hooks that hold the workpiece securely above the bench (main photo). This provides clearance underneath for bits and blades, letting you work directly over the bench.

EASY TO USE. As useful as they are, I'd have to say that these bench hooks are a bit unusual looking. So it's not immediately apparent how they work — until you put them to use. To do that, simply set a bench hook on the bench and push it forward until the heel catches the edge of the bench (inset photo). Then place the workpiece on top and butt it against the stop at the end. Several of them spread apart can support any size workpiece.

To make the piece stay put as you work, just continue pressing it against the stop. A light touch is all that's needed. And since the heel is engaged on the bench, this pressure keeps the bench hook from shifting forward. Small blocks attached to the sides of the body of the bench hook keep it from tipping side-to-side.

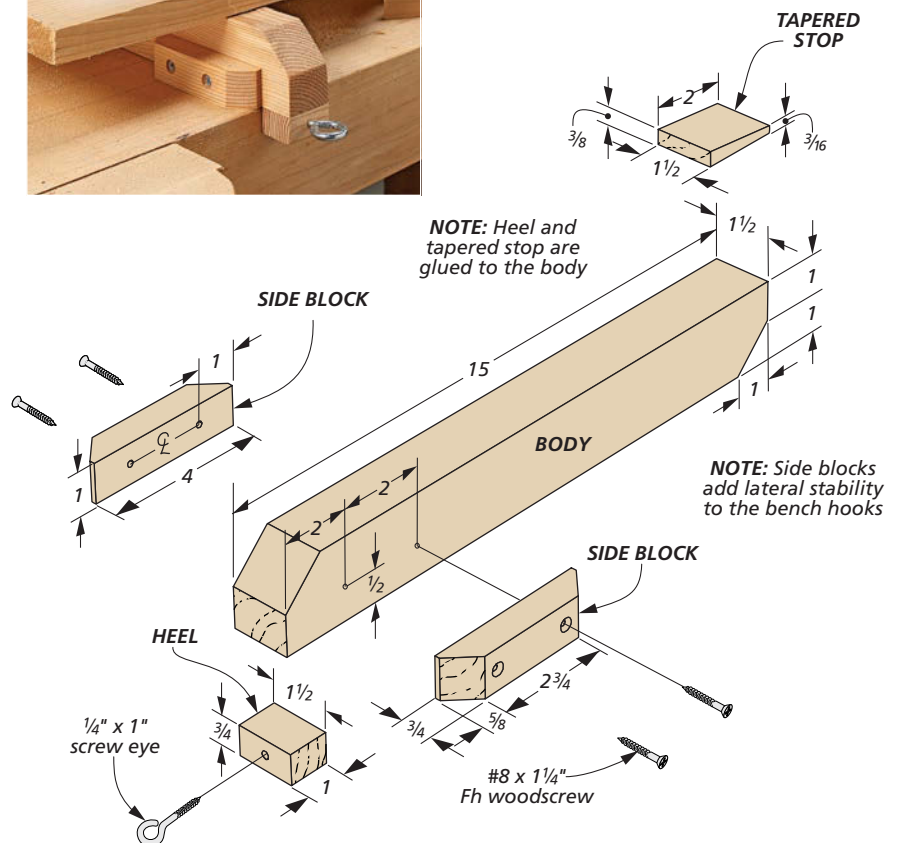



Small Center Finder

A center finder is a simple layout tool that comes in handy all the time in my shop. And if you're interested in making your own, it's not very difficult to do so using scrap wood, a pencil, and a few basic pieces of hardware, as you can see in the photo and drawings below.

To make it, start with a hardwood blank cut to final size. Before cutting it to shape, I drilled the holes for the pencil and aluminum rods. Careful layout work ensures the three holes are in alignment. The pencil hole must also be centered between the pair of holes for the rods. Then you can cut the body to shape.

After that, I cut the aluminum pins to length and secured them in the holes with epoxy. The pencil is held in place with a screw eye that is threaded into place.



Simple Saddle Square

There are many commercial saddle squares available that allow you to mark three adjacent faces of a workpiece without moving the square, but they're rather expensive. What I wanted was a three-sided saddle square that wouldn't break the bank. What I came up with is the simple square that you can see in the photo above and in the drawing below.

PLYWOOD PARTS. This saddle square is made from four plywood parts and some common hardware items. The fixed jaw has two guides glued in notches at the top corners. I cut the notches at the band saw. The rear, sliding jaw gets a threaded insert installed as shown below. A cap screw and small spring hold the sliding jaw in position. Depending on the spring's tension, this square will adjust to accommodate workpieces from $\frac{1}{4}$ " to $1\frac{1}{4}$ " thick.

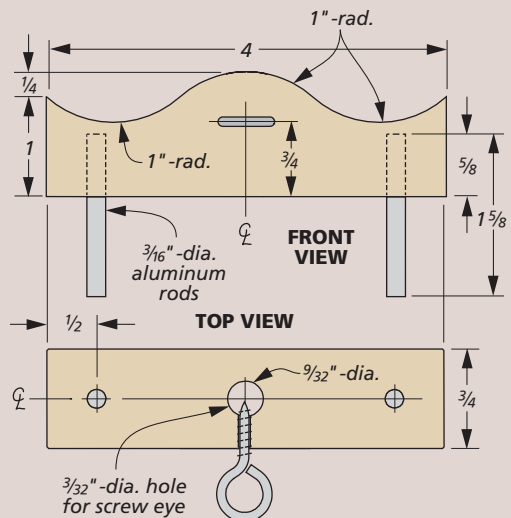
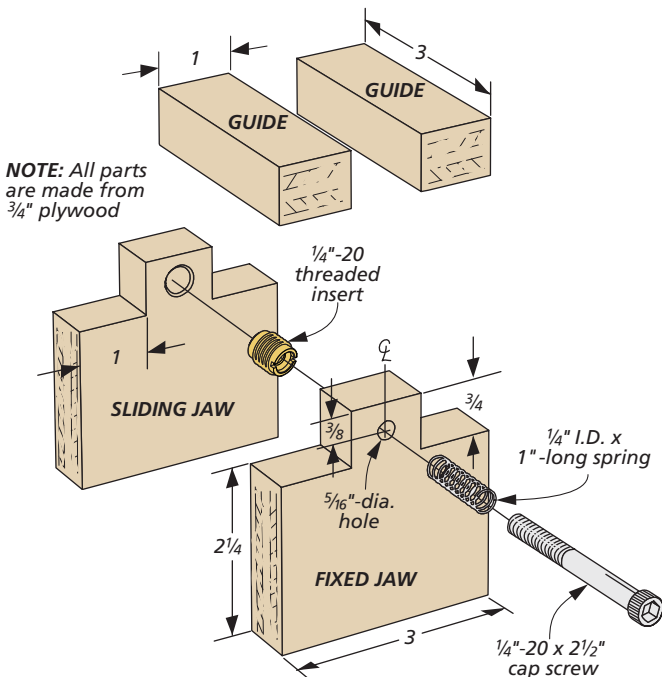



shop-made Straightedge Guides

With hardboard and plywood scraps, you can make a handy guide for your router and circular saw cuts.

If you visit the shop of any seasoned woodworker, chances are you'll see a collection of shop-built jigs and fixtures to go along with the tools. There's a very good

reason for this: As your skills increase and you build more projects, you'll gradually add some handy helpers to make common operations easier to accomplish, with more accurate results.



Dual-Use Jig. This simple, two-part jig can be customized for routing dados (main photo) or cutting sheet goods (inset).

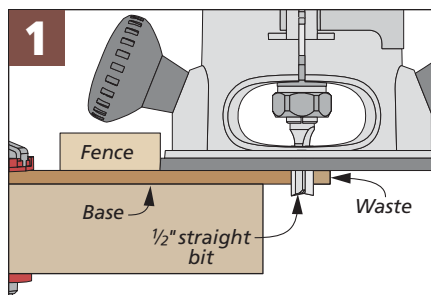

NOTE: Size width of base and glue on fence to accommodate tools you'll use the jig with (Figures 1 and 2)

A GREAT STARTER JIG. Of course, jigs come in all shapes and sizes and can be made for just about every tool. But as far as simple and useful jigs go, one I turn to time and again is the shop-made

straightedge guide shown above. With a piece of hardboard, a strip of plywood, and some glue, you can make a cutting guide that's invaluable for cutting dados, grooves, and rabbets and even breaking down larger sheet goods with a circular saw.

UNDERSTANDING THE EDGE GUIDE. As shown in the drawing on the left, there isn't a whole lot to this straightedge guide. It's just a wide base made from hardboard with a narrower plywood fence glued

to the top. As for the overall length of the guide, you can really make it any length that you want. I'll talk about some considerations in just a minute. One thing that's key when creating

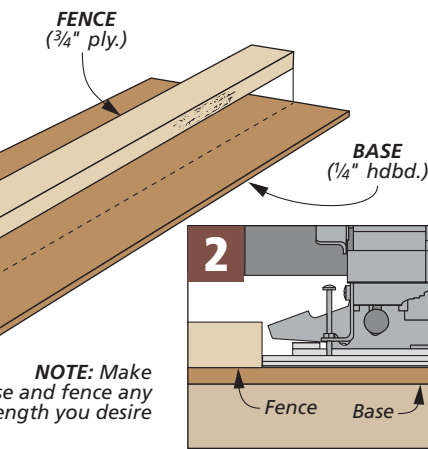

the guide is making sure that the hardboard extends well past both sides of the plywood fence as you glue and clamp it on. This is for the next step in the process, which is the secret to the guide's versatility, as well as its accuracy.

You see, after building the guide as shown in the drawing, you actually trim the edge of the hardboard with the tool you're planning to use with the guide. The end result is a base that will line up precisely with your desired cutline when using that tool.

You have several options for this step. For example, you can equip your router with a $\frac{1}{2}$ " straight bit for cutting $\frac{1}{2}$ " dadoes and grooves, and then trim the edge of the hardboard with that bit (refer to Figure 1 on the previous page). Or cut along it with a circular saw to create a precision cutoff guide for breaking down plywood panels, as shown Figure 2. In fact, the guide shown in the photos on the previous page is set up for both tools. You can use the router along one edge and the circular saw along the other.

ONE JIG, MANY USES. Really, these ideas are just the beginning of this jig's versatility. Starting with the basic concept shown in the drawings on the previous page, you can adapt the jig for a variety of different tasks.

CHANGE THE LENGTH. For example, it's possible to make it as long or as short as you'd

like for various sizes of project parts. If your main use for the jig will be for dadoes across narrow case sides, for example, then it probably doesn't need to be any longer than 28". But if you plan to use the guide for routing grooves or breaking down full sheets of plywood, then simply make the guide 54" long or even longer yet.

ADD A CLEAT. I use a square for positioning the guide on my workpiece (photo, right). But if you'd like to build that feature into the guide, another potential modification is to add a cleat to the underside of the base that's perpendicular with the fence.

ROUTER JOINERY. I already discussed how easy it is to make a guide for cutting both dadoes with a router and sheet goods with a circular saw. Another option is to make a double-sided guide that's set up for using two different diameters of straight router bits. If you find that you cut a lot of $\frac{1}{2}$ " and $\frac{3}{4}$ " dadoes and grooves, simply cut down one side of the hardboard base with a $\frac{1}{2}$ " bit. Next, rout down the opposite side with a $\frac{3}{4}$ " bit. Like that, you have one guide that can accurately cut two different sizes of dadoes or grooves. Just make sure to label the hardboard bases of the jigs clearly, so that you'll know what each side of the jig is for when you need to use it again in the future.

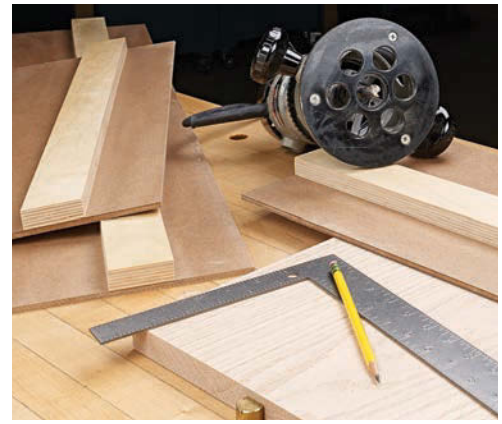

Make Several. I like to make several guides, such as the 28" and 54" ones shown, to tackle various cutting and routing operations.

CUSTOM DADOES & GROOVES. Another interesting twist on this idea is featured in the box below. In this case, you make two guides and trim the edges with a bit that's smaller than the intended dado or groove. Then using the sequence shown in the photos below, cut a custom-size dado or groove that's precisely matched to the thickness of the mating workpiece.

MUST-HAVE ACCESSORY. There's no question that my shop is outfitted with all kinds of jigs, some basic and some quite elaborate. And while these shop-made straightedge guides are some of the simplest jigs I have, I also find that I use them more than many of the others. I'm guessing that you probably will, too. **W**

How-To: Rout a Custom-Size Dado



Guide 1. After laying out one edge of the dado, clamp the first straightedge guide tightly against the layout line.



Guide 2. Next, use a scrap of the material that will go into the dado to position the second guide. Then clamp that guide in place.



Rout. Complete the dado by routing against the fence of one guide (shown) and back down the other guide.





perfect joinery & Assemblies

This is where it all comes together — gluing and clamping your parts to produce the finished product. You can be assured of better results by checking the strategies on the following pages first.

SQUARING UP A MORTISE.....82

BETTER-FITTING TENONS.....84

TIPS & TECHNIQUES.....88

GETTING READY FOR GLUEUP96

VERSATILE MITER JIG.....98



squaring up a Mortise

Anyone can cut a mortise, but creating a smooth, precision hole that fits a tenon like a hand in a glove takes a little bit of extra finesse. Here's how it's done.

Whenever I'm making a mortise for a project in *Woodsmith*, I have a go-to method that I rely on — drilling out the waste with a series of overlapping holes and then squaring up the mortise with a chisel. Drilling out the waste is pretty straightforward, aside from a couple of minor details that I'll get into later. But there's a little more to squaring up the mortise than meets the eye. In order to get a crisp mortise that fits the tenon

like a glove, there's a simple procedure that I like to follow. It's certainly not the only way to approach the task, but it's a method that works for me.

PUT AWAY YOUR PENCILS. Getting a square mortise starts with a good, accurate layout. While a pencil is useful for some layout tasks, I prefer a cutting gauge (or marking knife) for laying out a mortise, as shown in Figure 1. A cutting gauge will scribe a shallow groove in the

wood fibers. This groove acts as a registration point to align your chisel when squaring up the mortise. A pencil line just isn't as accurate.

DRILLING. Drilling out the waste is a pretty straightforward task. But a couple of points are worth mentioning here. First, I like to select a drill bit slightly smaller in diameter than the width of the mortise. For example, if I'm cutting a $\frac{3}{8}$ "-wide mortise, I use a $\frac{5}{16}$ " drill bit.

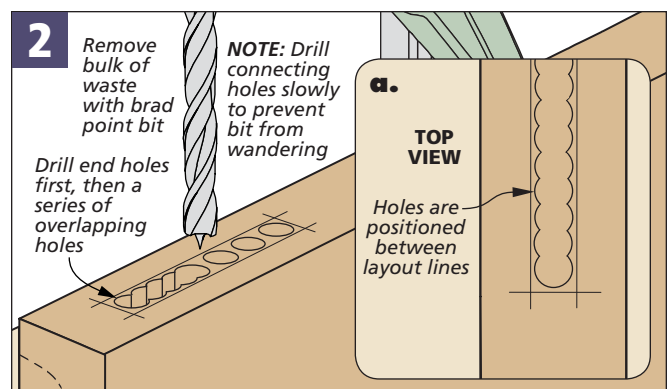
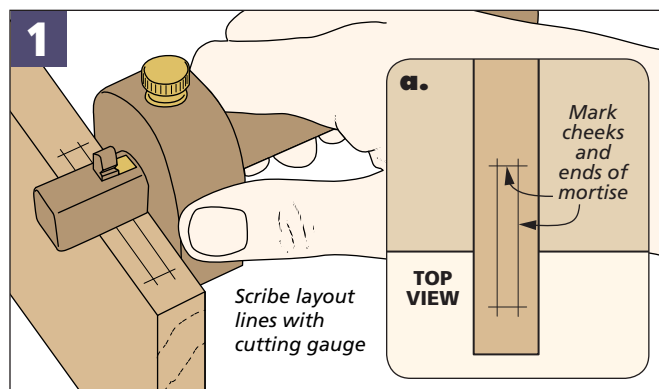

The goal is to preserve the scribed layout lines that you made with your cutting gauge. Using a smaller diameter bit ensures that the holes you drill will stay inside those layout lines, even if your drill bit drifts or wanders.

When it comes to actually drilling the holes, I start with a hole at each end of the mortise first, just shy of the layout lines. Then I drill a series of overlapping holes to join them (Figure 2).

TWO CHISELS. Once you've finished up at the drill press, clamp your workpiece in your bench to get started on squaring up the mortise. The first step is to select your chisels. The size of chisels I use depends on the width and length of the mortise. But I almost always use two chisels — a wide one to clean up the cheeks of the mortise and a narrow one to square up the ends.

For the narrow chisel, I usually choose one that is the same size or slightly narrower than the width of the mortise. For the wide chisel, I tend to grab the widest chisel I have on hand that will fit lengthwise in the mortise, usually 1" or wider. The wider the chisel, the faster you can work and the easier it is to get a flat surface on the wall of the mortise.

START WITH THE CHEEKS. My preference is to clean up the cheeks first and then focus on the ends. The cheeks seem to go quickly, so I like to get them out of the way before concentrating on the ends of the mortise.

If you look at the upper photo at right, you'll see that the drill bit leaves behind a row of peaks where the waste is drilled out. I like to start by quickly

knocking down these peaks with my wide chisel, removing the waste to within about $\frac{1}{32}$ " of the layout line. You don't need a mallet to do this; hand pressure is sufficient. This should leave you with just a thin layer of material to remove on each face of the mortise.

Place the chisel into the scribed layout line on the side of the mortise and pare straight down. Aim for holding the chisel as vertical as possible (Figure 3).

I like to use the weight of my upper body to power the chisel, but you can use a mallet if you prefer. As you pare down to the bottom of the mortise, use the back of the chisel to help guide the cut, keeping it tight against the side of the mortise. Once you have the first cheek nice and smooth, turn the workpiece around and work on the other cheek.

ATTACK THE ENDS. Squaring up the ends of the mortise takes a little more effort because you're chopping through end grain. I start by defining the end of the mortise. To do this, set your narrow chisel in the scribed layout line at the end of the mortise. While holding the chisel straight, give it a modest whack with a mallet. You're simply establishing the end of the mortise here, not trying to see how deep you can sink the chisel in a single blow.

Next, turn the chisel 90° and set it on the side of the mortise so it meets the cut you just made. Give the chisel another whack. Repeat the process on the opposite side, as shown in Figure 4.

With the end of the mortise clearly marked out by the chisel, flip your chisel over so the bevel is facing down and slice away the bit of waste in each corner, as shown in Figure 5. The waste should practically pop out with very little effort.



Paring. A wide chisel makes quick work of paring down the peaks left behind by the drill bit (top photo). Light, paring cuts result in a smooth-walled mortise (bottom photo).

Now it's just a matter of alternating between the vertical chopping cuts and the slicing cuts to work your way deeper and deeper to the bottom of the mortise. The key is to not chop out too much at one time, but instead focus on keeping the cuts straight and aligned.

Once you've completed both ends and cleaned up all the waste, you're ready to cut the tenon and fit it to the mortise. Here's where your hard work really pays off — starting with a square mortise will make the tenon-fitting process go a lot smoother and quicker. **W**

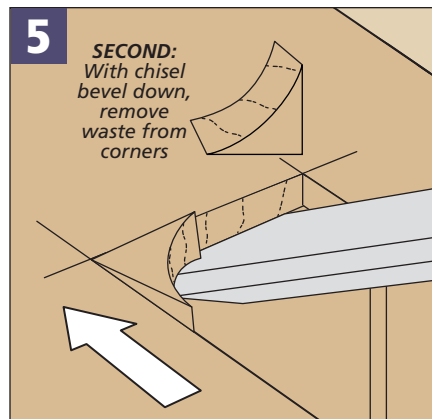
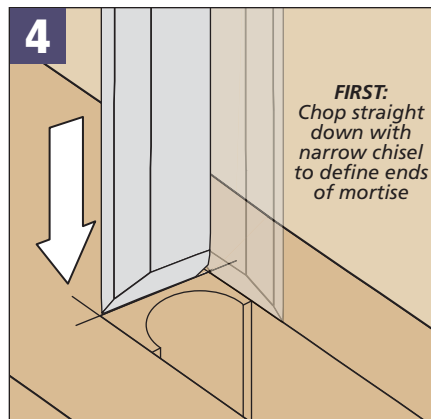
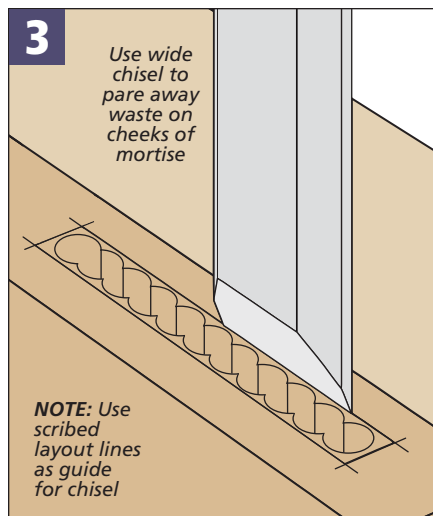

better-fitting Tenons

A careful approach and attention to detail as you cut will result in smooth, accurate tenons that will slide smoothly into their mortises each and every time.

Mortise and tenon joinery is a hallmark of solid, long-lasting construction. To improve your skills, it's helpful to take some time to zero in on one part of the process. Here, let's take a look at how to raise your tenon-making game.

YOUR TARGET. Before you get to the nitty-gritty of making and fine-tuning the fit of a tenon, I find it helpful to have an idea of the key details. The drawing and photos below

highlight what you're after. For me, there are two main points of attention: First, the connection between the wide cheeks of the tenon and the long-grain walls of the mortise. This gives the joint its strength. The other surfaces have at least one end-grain component and contribute very little to the overall strength of the joint.

The other detail that I key in on is a tight, even seam around the shoulders. This looks good, but it also resists the

forces that try to lever the pieces apart. As for the fit of the tenon at the ends of the mortise, I'm not concerned about that. In fact, a little gap here gives you some wiggle room to align parts at assembly.

Another aspect you don't need to worry about is making the length of the tenon match the depth of the mortise perfectly. I prefer the tenon to be a little short, so I don't have to worry about cleaning up the bottom of the mortise.

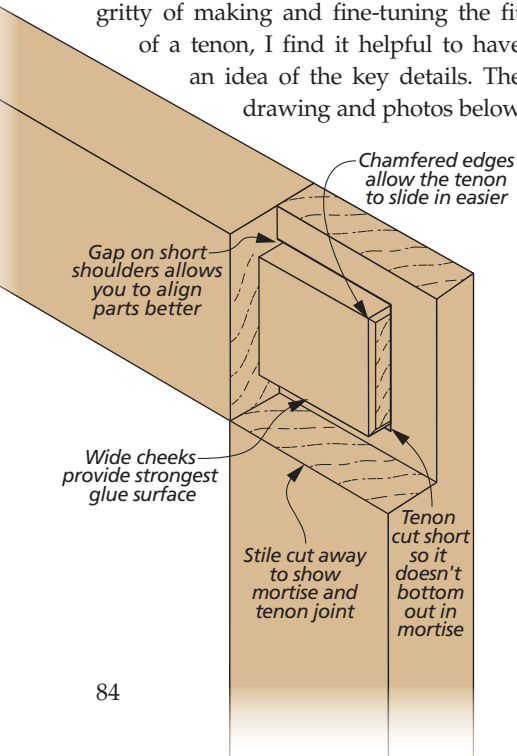

Fit. A properly sized tenon should fit into the mating mortise with moderate hand pressure or light mallet taps.



Check It. Another test for a tenon is to dry fit the joint and raise the mortised piece. The workpiece should stay in place.

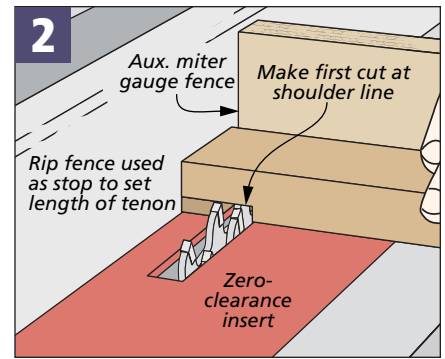
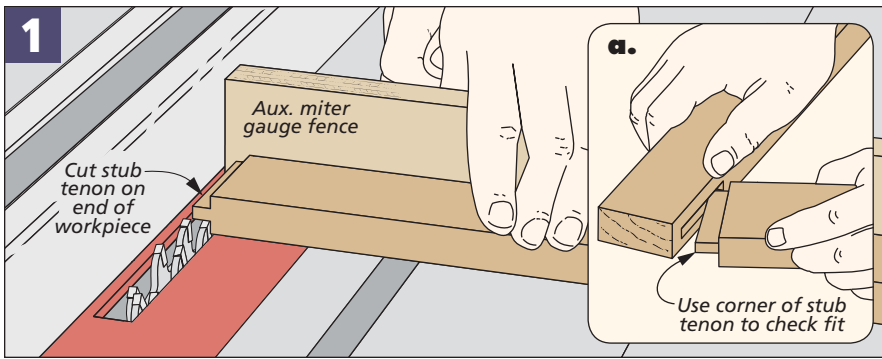

Adjust the Blade Height. Dial in on the correct blade height with test cuts across the tip of one test piece. The result is a stub tenon that will allow you to check the fit to the mortise. You're aiming for a fairly snug fit.

First Cut. Start with a cheek cut along the shoulder line, keeping the workpiece flat on the table and tight to the fence.

There are several good ways to make tenons. No matter which method you choose, your aim should be to get a good-fitting joint right from the tool. The less time and effort you spend in fine-tuning tenons means more time you have for other details. To get an idea of what I mean, I'll provide an overview of one popular and simple tenon technique.

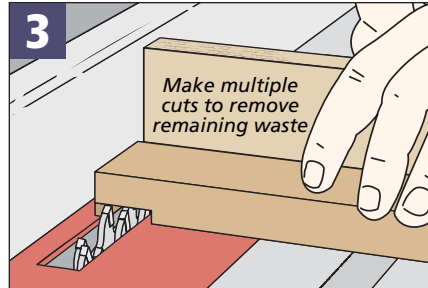

DADO BLADE METHOD. There's a reason that many woodworkers turn to a dado blade to cut tenons. The setup is simple, the process is straightforward, and with a little practice, the results are hard to beat. Long story short, you use a miter gauge to guide the workpiece across a wide dado blade to create each face of the tenon. Of course, there's more going on here than meets the eye.

Nibble Waste. Once the shoulder cut is made, start to nibble away the waste toward the end of the tenon.

Back & Forth. Remove ridges left by the dado blade to create a smoother tenon cheek and a better glue surface.

Prior to cutting the actual workpiece, I like to make a couple extra parts so they can be used as test pieces for setting up cuts. This takes away the pressure of trying to get things right on the first try.

on the correct blade height. I start with the dado blade set low and make a pass along each wide face. At this point, the stub should be too thick to fit the mortise.

longer than the width of your average dado blade. So you'll need to make multiple passes across the blade.

The drawings on this page run down the overall process. In Figure 1, you can see how to use a test piece to sneak up

SNUG FIT. Raise the dado blade a tad and make another pair of passes. Remember, you're removing material from each face, so don't raise the blade too much. You've reached your goal when you can just barely fit the tenon in.

These overlapping cuts can leave ridges that affect the fit of the tenon. To smooth them out, I slide the workpiece back and forth across the blade, as in Figure 4.

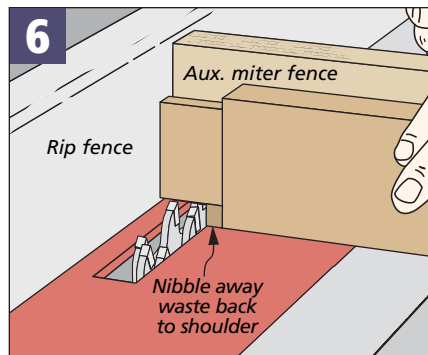
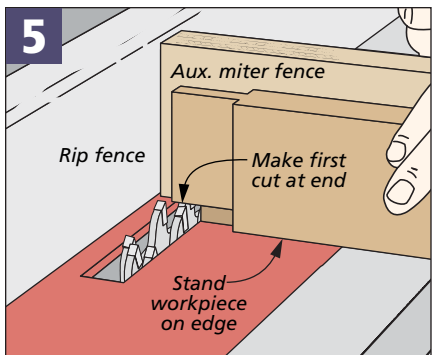

SHORT CHEEKS. The remaining step is cutting the end cheeks of the tenon. Here the workpiece is held on edge. Remember, this isn't a critical glue surface, so you don't need to worry about getting an air tight fit.

Edge Shoulders. You may need to adjust the blade height to cut the edge cheeks and shoulders of the tenon.

Edge Shoulders Last. Complete the tenon edge by making a careful cut along the short shoulders.

The margin photo shows what the results will look like. The cheeks of the tenon may still show light scoring marks. But overall, the cheeks are smooth, not ragged. If everything went well, then each tenon should slide home easily.



Dado. Here's the result of cutting a tenon by using a dado blade. The reality is a joint or two may show small gaps or may not close at all. On the next pages, I talk about the process for tracking down and fixing any problems.

troubleshooting Tenons

Taking the time and care to set up your table saw and cut accurate tenons pays off when it's time to fit the joints together. However, it isn't uncommon to end up with a couple of joints where you still need to do some additional work.

You may wonder why you have a problem at all if you've followed the steps I've already discussed. The answers cover a wide range: Individual workpieces may vary slightly in thickness or width. A part may have a subtle bow or curve. Depending on your technique, the mortise size may not be perfectly consistent. Whatever the reason, when the fit isn't right, you need to do a little detective work to diagnose the problem and fix it.

ONE STEP AT A TIME. On these pages are several common issues you're likely to run across. In some situations, you may have more than one problem going on. I find it's easier to take things one at a time. Focusing your attention on a single issue makes it easier to get a better-fitting joint in the end.

TOO THICK. I start with looking at the fit of the tenon cheeks to the sides of the mortise. After following the process on the previous pages, the most common problem occurs when the tenon is just a hair too big. It may fit only with a lot of clamping pressure, or firm mallet strokes. The danger here is that you run the risk



Plane. Trim tenon cheeks with a shoulder or rabbet plane, or a hardwood sanding block (inset). Take care to keep the tenon straight and parallel to the face of the workpiece.

of splitting the workpiece as you drive the tenon into the mortise. In addition, once the glue goes on, the joint may swell slightly. So you may be unable to even assemble the joint at that point.

The temptation is to take it back to the table saw and trim it. The problem is it's all too easy to take too much off. Instead, skip the table saw and reach for some hand tools to get the final fit. The photos above show two tools that accurately make the tenon thinner. Considering its name, it's no surprise that many woodworkers think a shoulder plane is just for trimming shoulders of tenons and rabbets. But actually, I find that this specialized tool is ideally suited for paring tenon cheeks.



A shoulder plane is narrow, so you need to trim a tenon in several passes. It's possible to create a tapered tenon, if you aren't careful. So check your progress often as you work.

The other tool is simpler by far — a sanding block. To keep the tenon flat, I use a hardwood block rather than a cork block. I apply adhesive-backed sandpaper to the block, leaving at least one edge without sandpaper. This "safe edge" prevents me from altering the shoulder of the joint unintentionally. I size the block so that I can sand the entire tenon cheek.

No matter which tool you use, the key is taking the same amount of material off each face. This keeps the tenon centered for a consistent fit of the overall assembly.

TOO THIN. The opposite problem is a tenon that drops into the mortise without any resistance. Don't worry, your workpiece isn't doomed to the scrap bin. To rescue it, you first need to make the tenon bigger. You do that by gluing a thin shim to each cheek. Clamp it firmly so that you have a gap-free connection between the shim and cheek.

When the glue is dry, refit the joint. I like to use relatively thick shims so I can recut the tenon at the table saw. If you use thin shims, you need to fit the joint with a shoulder plane or a sanding block.

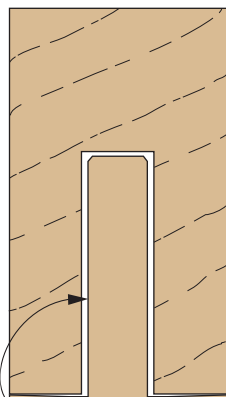

A narrow tenon prevents glue from forming a good wood-to-wood bond

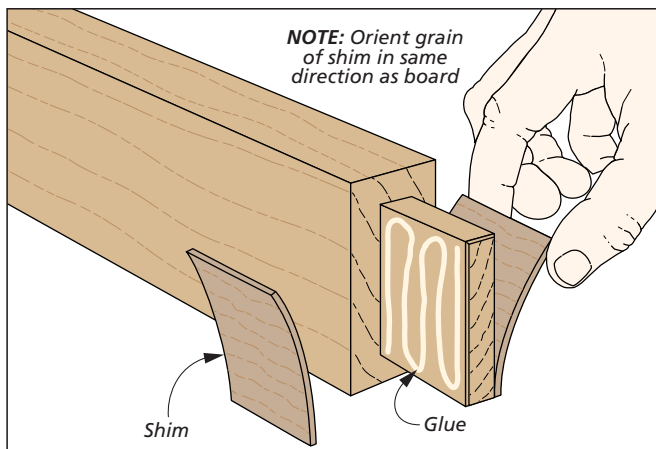

Shim a Small Tenon. If a tenon is too small, glue shims on each cheek. After the glue dries, you can recut the tenon at the table saw or trim it to size, as shown in the upper photos.

THE SHOULDERS. Taking care of the wide cheeks allows you to concentrate on other aspects of a strong and good-looking mortise and tenon joint. The next area of attention is the fit between the tenon shoulders and the mating piece that has the mortise.

Slide the joint together and examine the joint line along the two faces and both edges. If there's a gap all around the joint, the culprit could be that the tenon is bottoming out in the mortise. Check to make sure the mortise is clear of any chips. Then trim back the tenon slightly (if necessary), and reassemble the joint.

On a side note, I like to cut a small chamfer on the end of the tenon, as shown in the upper left photo on this page. This makes inserting the tenon easier and provides some glue relief.

EVEN SHOULDERS. Another problem is a step between the face and end shoulders. My tool of choice here is a chisel to remove the step (upper right photo).

When you're sure the shoulders are even and the joint still doesn't close tightly, there may be a small ridge of waste where the tenon cheeks meet the rim of the mortise. The remedy is to pare the waste away with a chisel. Take care not to cut into the tenon (near right photo).

Some woodworkers undercut the shoulders of a tenon to ensure a tight joint line. The idea here is that you hold the chisel at an angle to create a beveled shoulder where it meets the tenon (far right photo). If you do this, be sure to



Chamfer. A slight chamfer around the end of the tenon allows it to slide into the mortise easier, and it provides some glue relief.



Chisel. Cure stepped shoulders by taking small bites with a chisel. Register the chisel on the low side of the shoulder.



Ridge. A small ridge of waste where the tenon meets the shoulder can prevent a joint from seating. Trim it with a chisel.



Undercut. Undercutting the shoulder all around the tenon is another method for eliminating gaps. Leave a flat on the rim.

leave at least a $\frac{1}{16}$ " flat around the outer edges. If the flat is too narrow, the undercut shoulder may show up as a gap if you have to do a lot of sanding after assembly.

Now I said earlier that I don't tweak the mortise, but I sometimes make an exception. With the chisels out, it's easy to cut a slight chamfer around the edge of the mortise. This creates a small recess to accept

minor inconsistencies in the shoulder. And it also provides glue relief during assembly to reduce squeezeout.

ASSEMBLY. The final stage of the process is assembly. But beware, there are still hazards to avoid. The first is applying too much glue — and in the wrong places.

Instead, put the glue only where it matters most, the cheeks and sides of the mortise. This is shown in the photos at left. Brush a thin coat of glue on the wide cheeks of the tenon. Then use a paddle to put a coat on the mortise walls. Putting glue on both surfaces prevents starving the joint and creating a weak bond.

Now don't dawdle. Get the joints together quickly. Moisture in the glue can cause a tenon to swell and make it difficult to insert. It's easy to go from a just-right fit to too tight.

As you make the last turns on your clamps, the joint will close tightly. After applying these tips and techniques, it will be the last time you need to think about this joint. And peace of mind is a good destination if you ask me. **W**



Glue. Apply a thin, even coat of glue to the wide cheeks of the tenon. Too much glue here can lead to messy squeezeout.



Mortise. For the strongest joint, brush glue onto the side walls of the mortise. No other glue is necessary for solid assembly.

Quick Tip



NON-STICK CLAMPS

I got tired of glue getting all over my handscrew clamps, so I used contact adhesive to glue some small pieces of laminate to the jaw faces.



Right Angle Clamp

When assembling butt joints, it's sometimes difficult to hold two workpieces, drill pilot holes, and install screws, all while keeping everything perfectly aligned. To solve this problem, I came up with the right angle clamp shown in the photo above. It holds my workpieces at a perfect 90° while I pre-drill holes and drive screws.

ANGLE CLAMP DETAILS. The clamp consists of two fences. As shown in detail 'a,' the left fence is mitered 45° on one end. Three layers of plywood form the base of the clamp. All three layers are cut to the same

dimensions initially. The middle and top layers are then cut in half to form the slots.

A slide block fits in the middle slot and has a threaded insert in one end to accept the threaded rod. An insert in the top face of the slide block accepts a hex head bolt that secures the round clamp block. When assembling the clamp, I used a couple of spacers cut from scraps to maintain the spacing

of the slots in the top and middle layers. Be sure to wrap the spacers in wax paper to keep them from getting glued in place. Two cleats screwed to the bottom keeps the clamp elevated above the worksurface.

USING THE CLAMP. Insert your pieces in the clamp and turn the knob to pull the clamp block tight. The openings in the back of the fences allow room for drilling holes and driving screws in a workpiece.

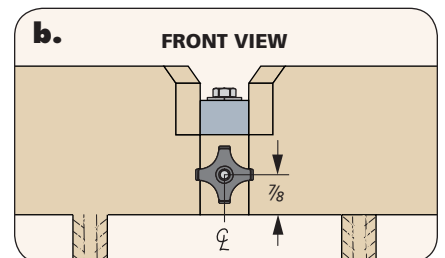
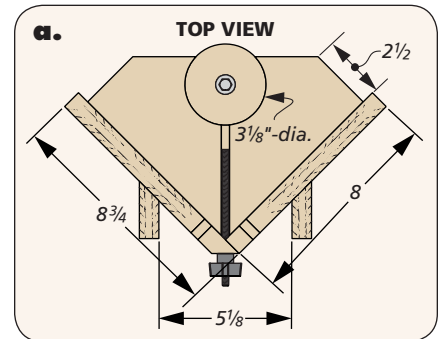
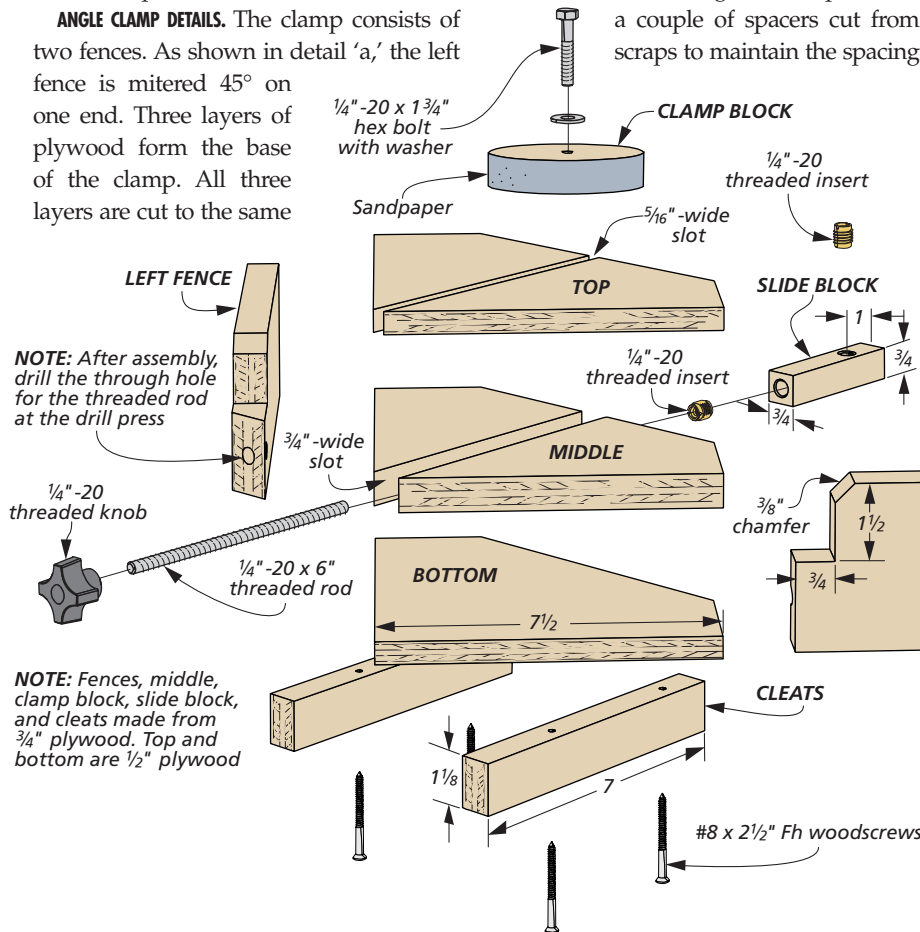

Glue Bottle Rack

Waiting for glue to flow from the bottom of the glue bottle to the tip is one of my pet peeves in the shop. Instead of waiting, I store a couple bottles in this handy rack that keeps the bottles upside-down so the glue is always ready to go.

EXPANDABLE DESIGN. I made my rack to hold the two bottles that I use the most, but it could easily be expanded by making the center sections longer. The whole rack is made from plywood. Tongues cut on the ends of the center sections slip into dadoes cut in the sides.

To add even more versatility, I drilled a large hole in the bottom tray that is sized to hold a disposable plastic cup. A glue brush rests in a groove cut next to the plastic cup hole. Excess glue drips into the cup.

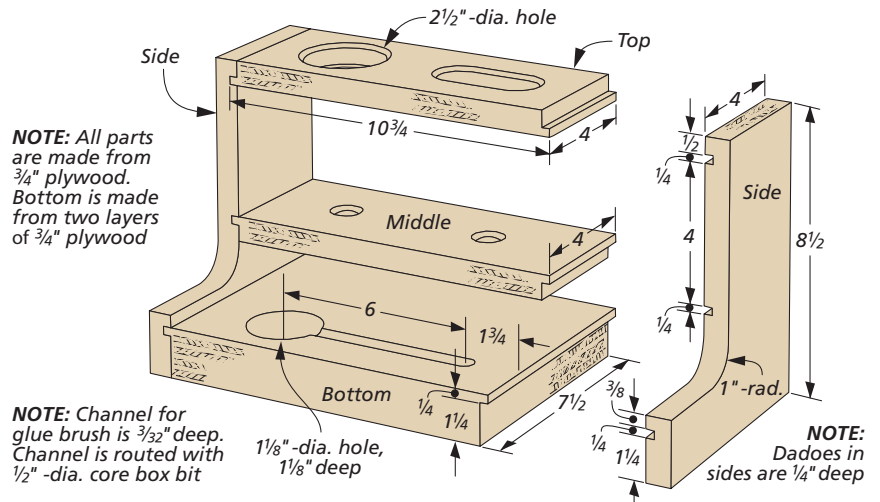
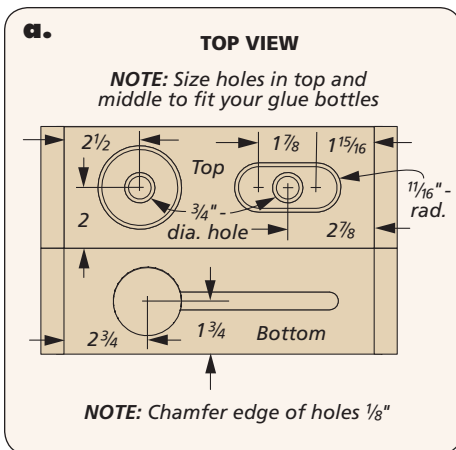

Quick Tips



PVC SUPPORTS

To support a workpiece while gluing or finishing, I used 3/4" PVC pipe with a tee fitting on the ends to keep the pipe from rolling. The supports are inexpensive to make and can be easily cleaned off when they get too messy.



STICKY CAP

I was having trouble with the caps on my Titebond glue bottles clogging up with dried glue after every use. I discovered that the cap from a French's mustard bottle fit perfectly. The plastic nib in the cap seals the bottle without clogging.

Multi-Miter Sled



I've found the table saw to be the most accurate way to make miter cuts for picture frames, table frames, and other similar projects. The trouble with using the table saw is that it takes eight individual cuts just to complete one frame. To solve this problem, I made the table saw sled shown above. It reduces the number of passes needed to make one frame from eight to three.

SLED DETAILS. As you can see in the drawing on the opposite page, the sled consists of a $\frac{1}{2}$ " plywood base with front and back bridges made from two pieces of $\frac{3}{4}$ " plywood laminated together. Two triangular fences attached to the base hold the four workpieces at the correct angle for mitering one end of each blank. Short sections of T-track sit in stopped grooves cut in the top of the fences. These T-track sections

house hold-down clamps used to secure the workpieces to the sled.

To cut the parts to length, a pair of fence extensions are secured to the T-tracks on the fences. They provide support for the workpieces. A section of T-track is attached to one side of each extension, allowing a stop block to slide along its length. The stop block can be locked in place to set the final length of your frame piece.

Quick Tips



CLEAN CLAMPING CAULS

I often use clamping cauls when gluing up boards into panels. Instead of tearing off fresh pieces of waxed paper to protect my cauls from glue, I keep my cauls wrapped in plastic wrapping film so they're always at the ready.



INEXPENSIVE CORNER CLAMPS

I often need to hold small project parts together at 90° for gluing or nailing. Since most commercially available assembly squares were too big for the job, I found that paper binder clips and metal angle brackets work just as well.

BUILDING THE SLED. Start by cutting the base to size. After gluing up the bridge pieces, shape them at the band saw. Round the upper edges, and attach them to the base with glue and screws. The miter bars are then attached to the bottom of the base using screws. These are spaced to accommodate the miter slots on your saw. Now, place the sled on the table saw and cut into the bridges and base to create the kerf.

FENCES. Use a combination square to lay out and cut the fences to size. You can then rout the stopped dados along the edges. After installing the T-tracks in the grooves, attach the fences to the base using glue and screws.

STOP GUIDES. Now cut the fence extensions and the keys to size. The keys fit in the opening of the T-track on the fences. The fence extensions are held in place with a knob and flange bolt. Next, screw a section of T-track to the extension. The stop block construction is similar to the fence extensions with a hardboard key fit



Miters. Be sure to keep the frame pieces oriented in the right direction when making the second and third passes. Labeling the pieces after the first cut helps to keep them in order.

into a dado. A knob and flange bolt are used to hold it to the T-track.

USING THE SLED. To cut miters, start by placing four frame pieces on the sled so they just overlap the kerf line. Lock them down as shown in the main photo. Pass the sled over the blade to make the first cut on all four pieces. Now remove the frame pieces and install the two fence extensions.

Orient the extensions as shown in the photo above and lock them down in the T-tracks.

Set one stop block for the length of a frame stile and the other for the length of a rail. Insert one stile and one rail piece on the sled, lock them down, and pass the sled over the blade to make the second cut. Finally, install the other stile and rail and cut them to size.

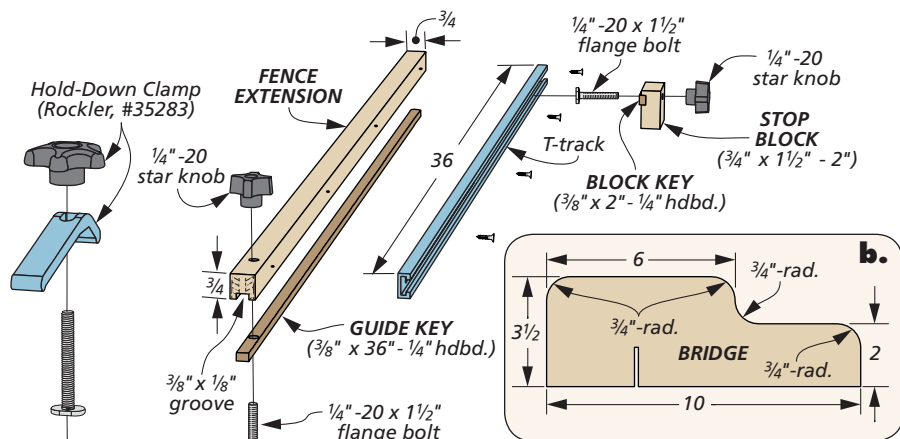
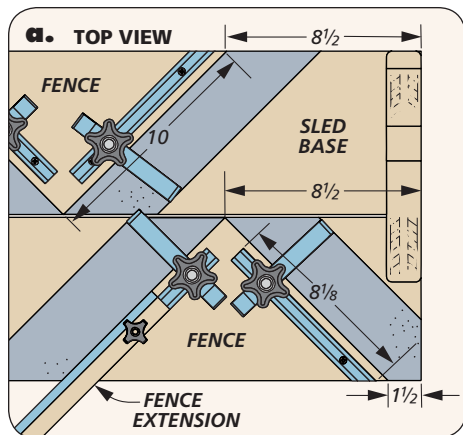

NOTE: Sled made from 1/2" plywood. Fences are made from 3/4" plywood. Bridges are made from two layers of 3/4" plywood

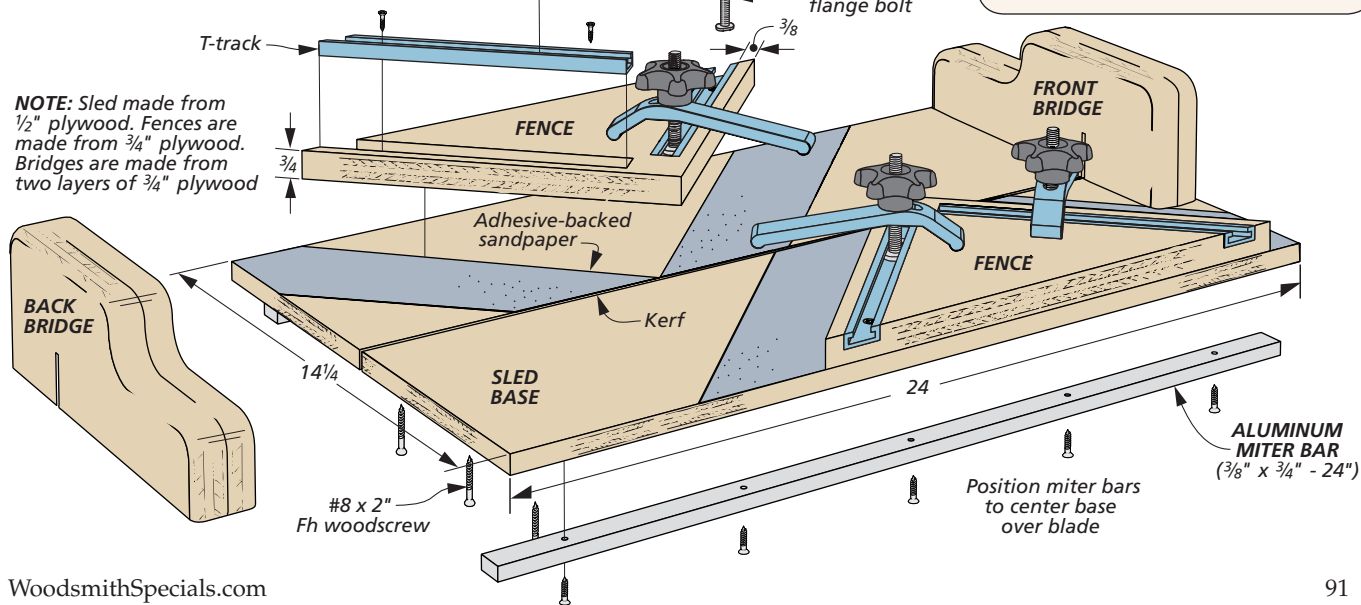

Easy Edge Banding Clamp

Recently, while applying hardwood edging to some plywood shelves for a bookcase, I ran short of the necessary clamps to finish all of the glueups. With only spring clamps left in my arsenal, I came up with a clever way to accomplish the task. I used rubber strips cut from a bicycle inner tube to clamp the edging in place.

Strips of Tubing. I started by cutting the inner tube into strips long enough to wrap around the top edge of the panel. These should also be long enough so the rubber extends below the tips of the jaws on the spring clamps.

Clamp It Up. Place the glued-up hardwood edging on the plywood panel and hold a piece of tubing in place with a spring clamp. To increase tension, simply pull down on the tubing sticking out below the clamp jaws.



Clamp Handle Hand Grip

Getting a firm grasp on bar clamp handles can be hard at times. Dry, winter hands combined with a touch of arthritis can take the fun out of my shop time real fast, that's especially true on a project that calls for a lot of clamps.

GET A GRIP ON IT. A good fix for this is a simple plywood wheel that slides on to the clamp handle. A slot in the wheel and a screw lets you cinch the wheel firmly in place. The size of the handle hole may vary depending on your clamp handles.

For the clamp size shown here, the handle wheel starts as a 3 1/4"- square piece of plywood. First, drill a hole in the center with a 1 1/8" Forstner bit. Next, cut the relief slot centered on the side of the block at the band saw. Then drill the pilot and counterbored clearance hole for the screw (detail 'a'). Next, head to the band saw and cut out the outer circumference. Then, to finish up, sand the wheel smooth before installing it on the clamp handle.

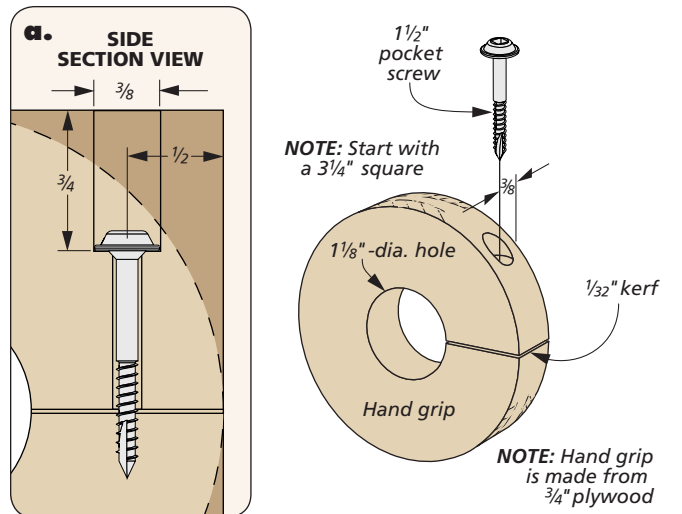

Quick Tip



ATTACHING CAULS TO CLAMPS

I have a solid fix for a wobbly problem. By cutting V-grooves in small blocks and screwing them to my bar clamp pads, I no longer have to struggle when clamping curved shapes.

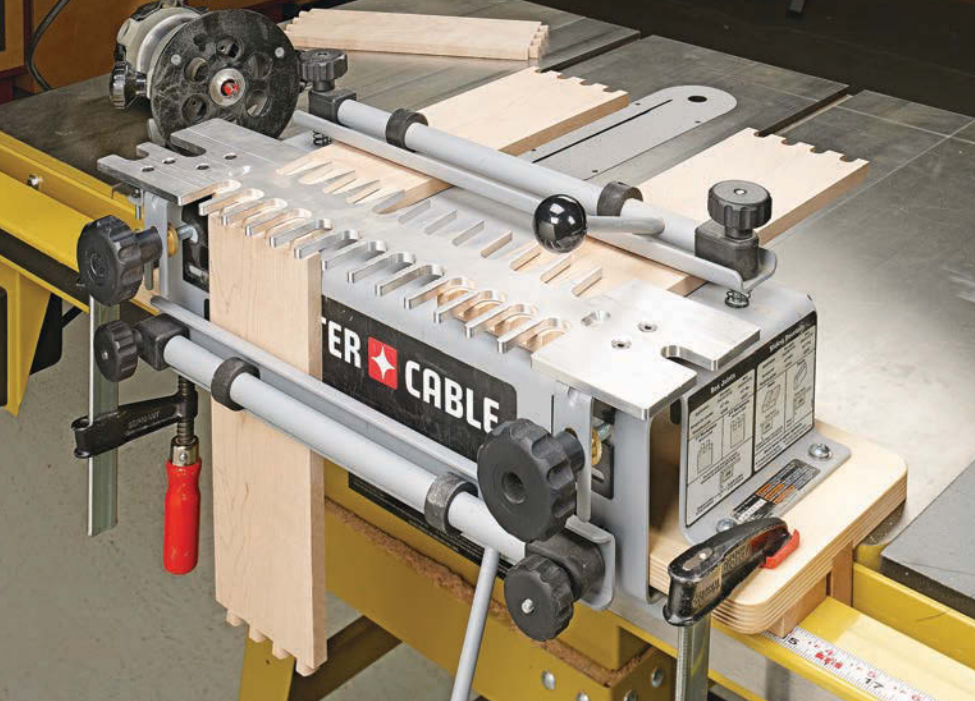

Portable Tool Mounts

When I'm knee-deep into a project, my workbench can get pretty cluttered. If I need a space to temporarily mount a portable tool or jig, like my dovetail jig shown at left, there's often no room to be found. I came up with the perfect solution using my table saw's fence rail system.

SIMPLE PLATFORM. My table saw has a gap between the L-shaped mounting bracket and the rail that the fence rides on. I sized a board to fit in that gap and then attached it to a platform that's sized to fit my dovetail jig. Another board attached to the bottom of the platform acts as a spacer to bring the platform level with the top of the saw table. The whole assembly is then clamped to the fence rail. It's easy to customize these mounts for other benchtop tools.

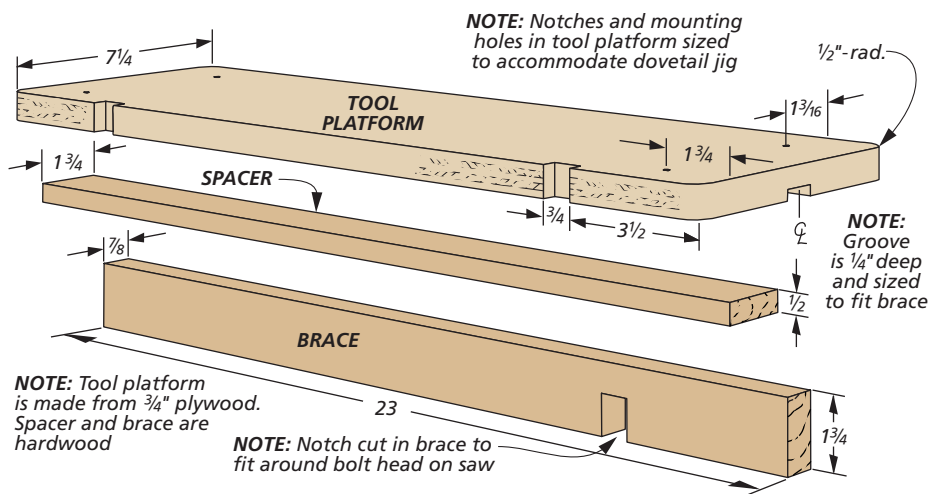

Quick Tips



SHOP-MADE BAND CLAMPS

While assembling some small boxes in my shop one day, I ran out of band clamps. I improvised by cutting the hooks off of an inexpensive tie-down strap. I reattached the loose end by tying it to the ratchet housing.



HANDY GLUE POT

I couldn't justify the expense of buying a dedicated glue bowl. I found that plastic chewing gum containers work perfectly for holding glue. They'll even keep the glue fresh for several days when closed.

Locking Pipe Clamp Stands

I use a shop-built table with T-tracks set into the top for most of my assembly work. But even with a dedicated assembly table, my pipe clamps are oftentimes too long to sit on the table. To help support my clamps, I made several of these pipe clamp stands (inset photo) that lock in place in the T-track.

Each clamp stand consists of a hardboard base with an upright made from MDF. A threaded knob, hex bolt, and washer lock the stand to the T-track.

Start by gluing a couple pieces of MDF together. The pieces should be large enough so that when trimmed to size they yield two stands. I then drilled a hole slightly larger than the diameter of the pipe clamps and cut the piece in half through the center of the hole. All that's left is to chamfer the edges and glue it to the base.

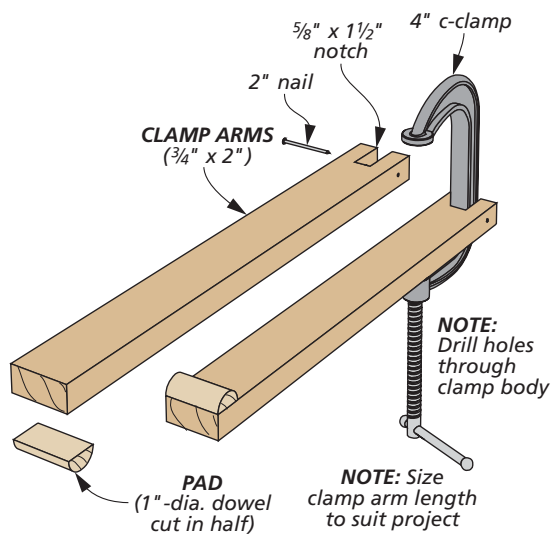
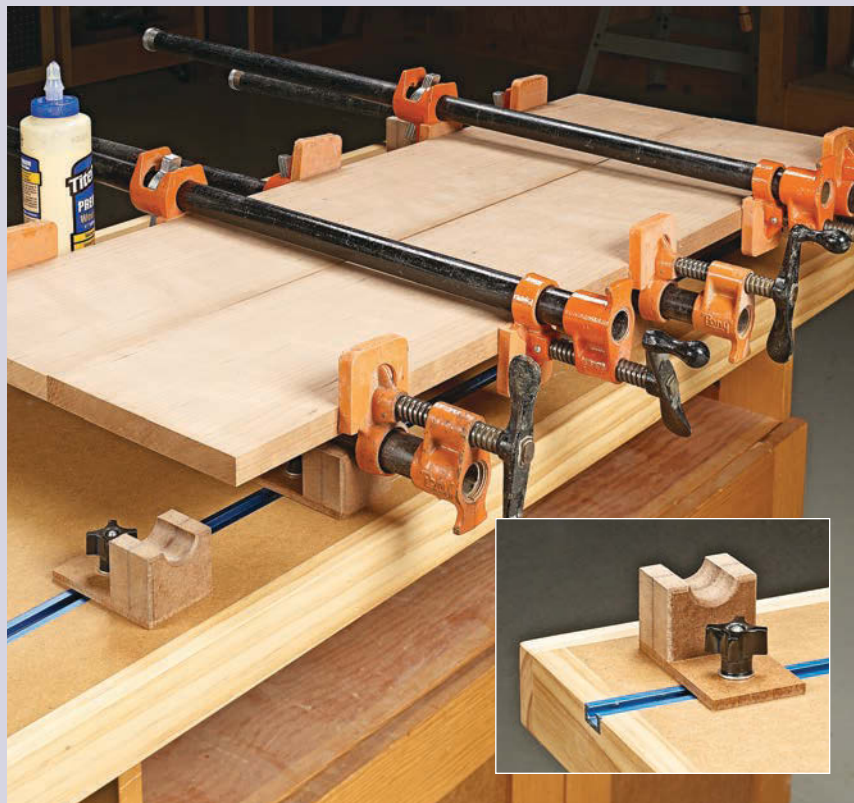

Extended Reach Clamps

I've occasionally had a need to put clamping pressure on a spot that was out of reach of any of my clamps. Since I could never justify the cost of long reach clamps, I add an extended set of jaws to some of the C-clamps that I already had among my clamp collection.

Start by cutting two pieces of hardwood that will reach the spot you need to clamp. Then drill a hole through one end and cut a notch to fit around the bars to the clamp body. Do this for both pieces.

You can drill holes through the clamp body at points that will provide the

throat distance you need, accounting for some deflection of the arms. I glued two pads to the bars and then attached the bars to the clamp body with a nail.

When you're done, you can remove the extended jaws and return the C-clamp to its intended function.

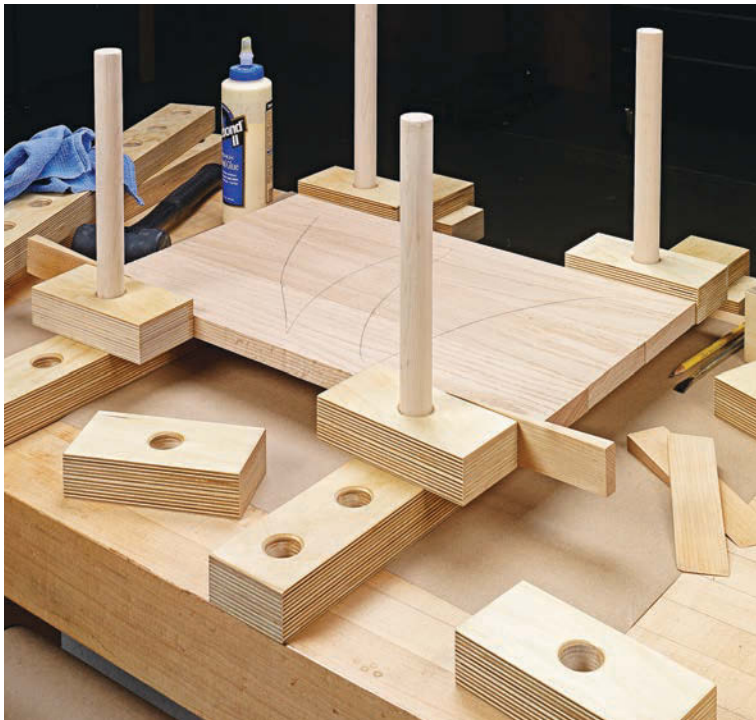

Dowels. A dowel recessed in one end of a base frame, and a cleat at the other end, hold them steady during use.



Multiples. Making multiple frames allows you to stack them vertically. The hardwood wedges secure the panels.

Panel Assembly System

For many projects, I find myself gluing up narrow boards to create wider panels. But because of the small size of my workshop, it seems that I always run out of work-surfaces after only a couple of panels are glued up and clamped.

Instead of spreading my work out, I devised this panel assembly system that fits on my workbench and allows me to

work up. This system employs a series of wedges, clamp blocks, and dowels, as you can see in the main photo above.

HOW IT WORKS. These parts work in conjunction with some adjustable frames. The frames are sized to fit across my workbench. They have evenly spaced holes along their length to hold the dowels. A dowel glued to the underside of one

end fits into a doghole in my bench, while the other end has a cleat that butts up against the edge of the workbench (upper right photo). This cleat keeps the frames from moving as I glue up the panels.

This panel clamping system can be customized to fit just about any size workbench that has dogholes in the surface. The best part is, you can make as many frame pieces and clamping blocks as you'd like. This allows you to "stack" your panel assemblies vertically, as shown in the lower right photo above. So even in a small shop, you'll rarely run out of worksurface space, even when working on projects with multiple panel glueups.

NOTE: Frames, clamp blocks, and cleats are made from two layers of 3/4" plywood. Wedge is 1/2"-thick hardwood. Long dowel is 1"-dia. hardwood. Short dowel is 3/4"-dia. hardwood

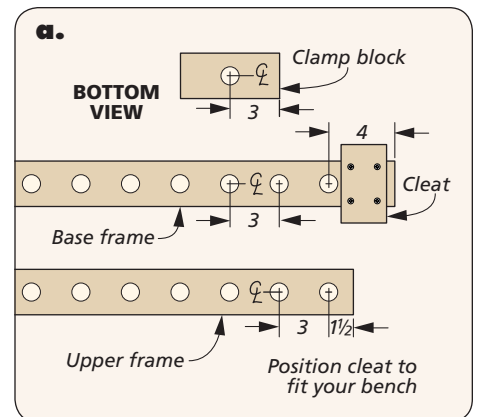
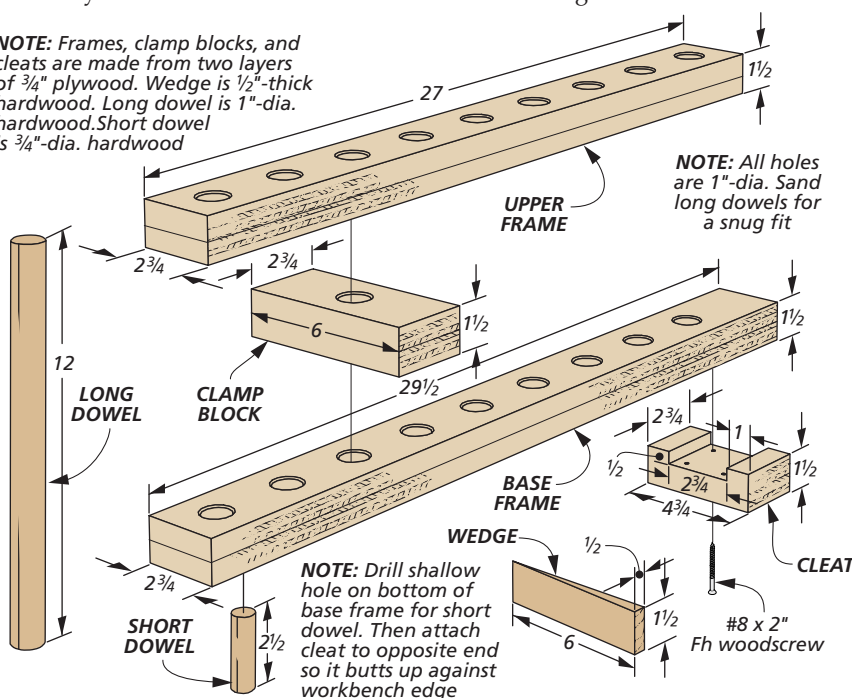



getting ready for Glueup

The perfect project all comes together with a well-executed glueup. To get there, you need to do the prep work beforehand to make sure it all goes smoothly.

You know the moment. It's the time when part or all of your project is ready for assembly. And frankly, you're a little anxious to start seeing it take shape. I find this time to be both exciting and a little nerve-racking.

I've had my share of projects go awry by being too eager to get things glued up. Over time, I've learned to slow down and think about what needs to happen

in order to have a successful assembly. There are four areas you'll want to address before you start: the space, the gear you need, the dry run, and the clamps.

It's always a good idea to stop, take a deep breath, and plan the assembly steps with the same care you would plan out a tricky joinery operation.

CLEAR SOME SPACE. When I'm knee deep in a project, my shop can look, shall we

say, "cluttered." At assembly time, disorganization and a pileup of tools and supplies can lead to misplaced parts or clamps. It can even keep you from having the best access to the assembly.

Thankfully, the solution is pretty simple. Take a few minutes to clear away some space on a flat worksurface. I'm not talking about a deep, spring cleaning. For me the time is well spent because I slow down and think through the next steps.

Most of the time, I use my workbench for assembling a project. Two other options are the top of a table saw or a sheet of plywood set up on sawhorses. No matter what you choose, it's a good idea to protect the top from glue drips. A piece of kraft paper is ideal for this task (left photo). I keep a roll in my shop for assembly as well as finishing tasks.

There are a couple of preparations to make. One of those is to keep a few pieces of lumber on hand. These are used to raise project parts off the benchtop to allow greater access for clamps. In addition to the primary assembly area, I



Proper Setup. There's more to setting up an assembly area than freeing up space. Protect the worksurface with a sheet of kraft paper to catch glue drips. Then position the project parts, tools, and accessories you need close at hand to streamline the process.



Supplies. Glue and a brush are good starting points. A mallet helps coax parts together. A square and tape measure let you check for square. Tape and waxed paper prevent glue from causing problems.

Clamps. Long pipe clamps usually handle the main assembly. Add shorter bar clamps to help align parts. Throw in a few hardwood cauls and supports to distribute pressure, and you're ready to go.

find that it's essential to have a nearby staging area for the glue, clamps, and parts. This can be as simple as rolling a cart up to the bench or having a small counter space close at hand.

GATHER YOUR GEAR. Speaking of gear, on the surface it may seem that all you need is glue and clamps, and you're ready to get started. But I've found it's a little more involved than that.

Along with glue, you're also going to need a way to apply it. I like to pour some glue into a tray and use a silicone brush to spread it on joint surfaces. When it comes to glue, I like to use liquid hide glue. It gives you more open time to get parts together before it sets.

In addition to those essentials items, I have a tape measure, mallet, and square for checking and adjusting the alignment of parts (upper left photo). A roll of masking tape is also helpful.

You can apply tape to inside corners and other places that will be difficult to access after assembly. This way, any glue squeezeout will end up on the tape and not on your project.

I also like to keep everything accessible, but where it isn't likely to get knocked around. The idea is that with everything close at hand, you can minimize extra steps once the glue goes on. You'll feel more relaxed and get better results.

DRY RUN. The next step is to gather the parts you'll assemble and bring them together with clamps, but without glue, as shown in the photo below. This practice run serves a few purposes. First, it lets you double-check the fit of all the joints. You have one last chance for fine-tuning before the glue goes on. Joints should fit snugly, surfaces should be flush, and there shouldn't be gaps. The dry assembly process also gives you an

idea of the time involved in assembling a complex project. If it takes longer than 10 minutes, you may need to consider breaking the process down into easier-to-manage stages.

Finally, the run through allows you to arrange the parts on your assembly area in the right order and orientation. This keeps the process going smoothly and prevents parts from getting mixed up — or forgotten.

COLLECT YOUR CLAMPS. Performing a dry assembly reveals the type and number of clamps you need to get the job done, as you can see in the upper right photo. Most of the time, long bar clamps or pipe clamps do the lion's share of the assembly work. But they aren't the only players on the team.

Small clamps serve as third hands. Use them to hold parts in alignment during glueup. They can even help support the assembly as you bring in longer clamps.

Another key part of applying clamping pressure is using cauls. These pieces direct and distribute clamping pressure right where it's needed, as shown in the main photo on the previous page. It's also a good idea to make sure your clamps are fitted with plastic pads to prevent your work from getting marred by metal clamp jaws. You can make pads from hardboard, as well.

As with your supplies, take some time to place the clamps nearby but out of the way of the assembly. This way, you can reach them easily once you start.

Now the moment is at hand. All your prep work pays off as you glue up your project. Take a deep breath, and get started knowing the results are in the bag. **W**



Dry Assembly. A final dry assembly is a critical part to success. You can double-check the fit and get a good idea of the best order. Once the pieces are together, apply clamps to make sure the joints close up and that the assembly will be flat and square.



Versatile Miter Jig

Instead of a miter gauge, I prefer to use a sled for all of my crosscutting at the table saw. To avoid having to remove the sled to make mitered cuts, I came up with this simple jig. The

miter jig clamps to the crosscut sled to make accurate 45° cuts. Then it's quick to remove to use the crosscut sled for straight cuts. This jig is also versatile enough to be used by itself

by running it against the table saw rip fence to make mitered cuts.

To build the miter jig, start by cutting the hardboard base and the plywood clamp support to final size. Use a combination square to lay out the angles on the front edge. Taking extra care to lay out and cut these edges will ensure the accuracy of the jig. The base and clamp support are then held together with glue. The fence is cut from solid stock and is attached with screws through the bottom of the base and clamp support.

Making a miter cut using the jig is simple. Just clamp it to the back fence of the crosscut sled as shown in the main photo above. Make sure the jig lines up with the kerf line of the sled. (The jig can be placed on either side of the saw kerf.) Next, set a workpiece against the clamp support and lock it in place by using one of the toggle clamps on the sled. Now just push the crosscut sled forward to make the cut on your workpiece.

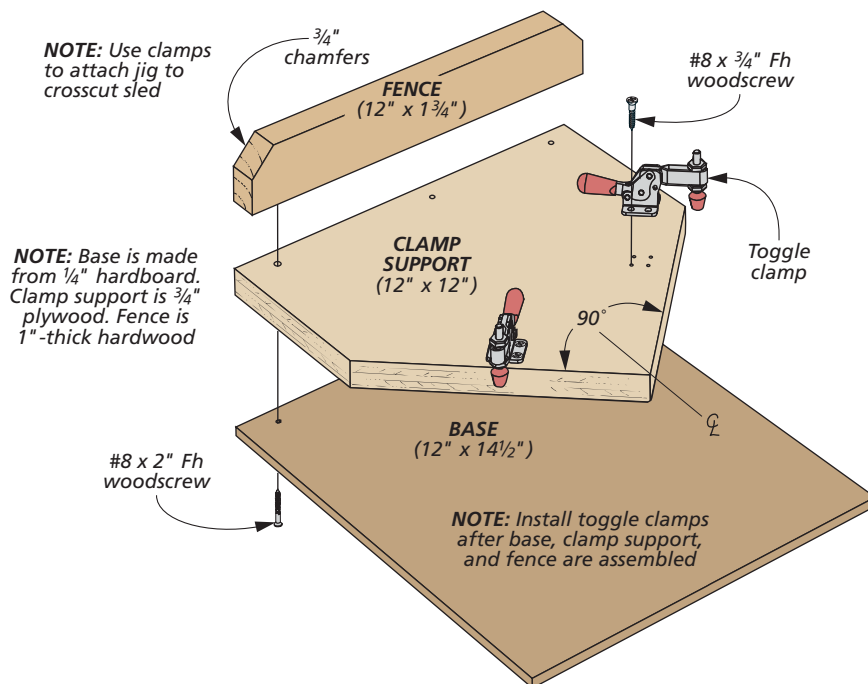

Woodsmith®

Discover More Great Woodsmith Books

from the publisher of
Woodworking Tips, Tricks & Jigs

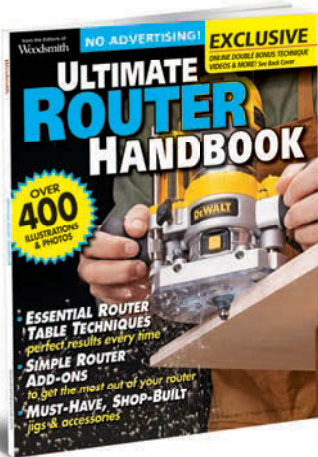

Ultimate Router Handbook

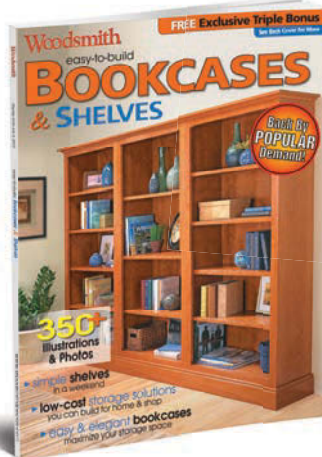

Easy-to-Build Bookcases & Shelves



Digital-only versions now available
Only \$7.95!

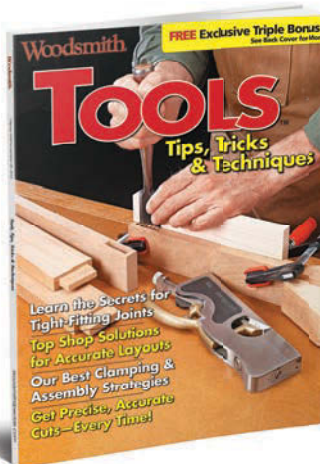

Tools, Tips, Tricks & Techniques

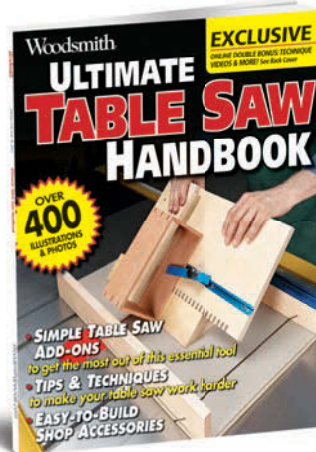

Ultimate Table Saw Handbook

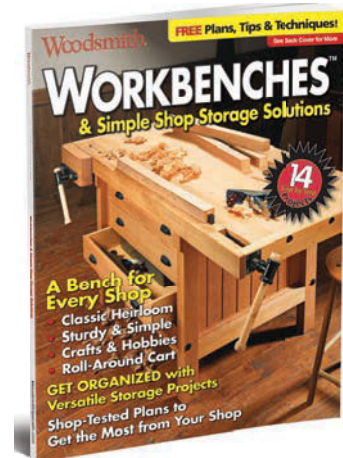

Workbenches & Simple Shop Storage Solutions

See these and more Woodsmith books at

WoodsmithStore.com

ONLINE TRIPLE BONUS!

1

10 Table Saw Jig Plans



- ➔ Easy-to-build jigs for any table saw
- ➔ Complete printable plans
- ➔ Easily accessible online
- ➔ Work faster, safer, and more accurately!

2

3 Bonus Plans



- ➔ Table Saw Miter Jig
- ➔ Small Parts Miter Box
- ➔ Quick & Easy Tool Storage

3

Free Weekly eTips!



Woodsmith eTIPS

- **Video Tips** from the Woodsmith Shop TV Show!
- **Woodworking Tips** to Print and Save
- **Special** Product Offers!

To get all your **FREE** bonus materials, go to WoodsmithSpecials.com and enter this access code



WTJ701