

**CELEB INTERVIEW** **p98**  
Get to know TV's  
*Leonie Pujol*



**YOUR FREE GIFT**    
6 stunning ideas to try!



**COLOUR CLINIC**   
Learn to use **Chameleon Pencils!**



Issue 171 July

# Cardmaking & Papercraft

The UK's No.1 cardmaking magazine

## Fresh ideas for summer

Special cards to make for birthdays, graduations, new babies, weddings and more!

### Inside this issue...

- \* **Parchment craft** made easy
- \* 6 top ideas with **VersaMark ink**
- \* **Summer trends** you can't miss



**FAB FLORALS**  
Craft this gorgeous wreath

**TRY NEW HUNKYDORY CRAFT STACKS**



**MASTERCLASS**  
Simple steps to pop-up cards



*Welcome to the world's first home and hobby cutting machine with a built-in scanner.*



**Cut it**



**See it**



**Scan it**



**Create it**

Scan any image or sketch, then precisely cut the shapes or outlines – without design cartridges or a PC.

Great range of accessories available including Rhinestone Kit, Printable Sticker Kit and much more.

**Exclusively available  
from Create and Craft TV**



Sky 674, Freeview 23  
Freesat 813, Virgin 748

Visit [www.scanncut.co.uk](http://www.scanncut.co.uk) for full details



**Sienna Parulis-Cook**  
Editor

# Welcome to the July issue

Make your summer an extra-crafty one with all the fantastic ideas in our July issue. Our gorgeous cover card was made by Paula Holifield using the **paper piecing technique** – turn to p18 to learn how to add patterned papers to your stamped designs to create perfectly coordinated cards and save loads of work colouring! Now is the season for **graduations**, and if you're celebrating any recent school-leavers or university grads, you can't miss Clare Buswell's amazing ideas on p46, from **mortarboard gift boxes** to **diploma cake toppers**! I've been lucky to work with celeb crafter **Leonie Pujol** for years on her regular magazine column (p56), but I learned so much interviewing her for our back page this month. For example, did you know she used to work at a stockbrokers? Turn to p98 for more surprises from this **craft TV star**!

Sienna



Dress up your stamped designs with the paper piecing technique  
page 18



Craft an unforgettable graduation party with these fab ideas  
page 46



*Our promise to you...*

- ★ The very best techniques, with detailed step-by-steps
- ★ Essential advice and knowhow from the UK's top experts
- ★ Gorgeous card ideas from all your favourite designers
- ★ An exclusive free gift every issue

## Meet the team!



**Robert**  
Art Editor

"It's impossible to pick a favourite among this month's treat cup cards, but I do love the fish bowl and piggy bank!"



**Jo**  
Deputy Editor

"Maria Simms has made such a pretty, summery card for her parchment craft tutorial – I'd definitely like to give it a go"



**Molly**  
Editorial Assistant

"I once visited the beautiful Neuschwanstein Castle in Bavaria and loved seeing it featured on a card this month!"



**Matilda**  
Designer

"I designed this month's peacock-themed bonus papers and am so impressed by the cards made with them"

For free downloads, tips and many more cardmaking ideas, visit  
[www.cardmakingandpapercraft.com](http://www.cardmakingandpapercraft.com)

Like it



[www.facebook.com/  
cardmakingmag](http://www.facebook.com/cardmakingmag)

Tweet it



[@cardmaking\\_mag](https://twitter.com/cardmaking_mag)

Pin it



[www.pinterest.com/  
cmpcmag](http://www.pinterest.com/cmpcmag)

Watch it



[www.youtube.com/  
cardmakingmag](http://www.youtube.com/cardmakingmag)

# Contents

## July 2017

### On the cover

#### Your free gift 10

Six ideas to make with your **Mermaid Wishes** stamps, embossing folder and paper pack

#### Knowhow stamping 18

Enhance stamped designs with **paper piecing**

#### Something for the weekend 24

Decorate your home with a **floral wreath**

#### Trend Spotter 41

**Flamingos** are everywhere this summer!

#### Masterclass 42

**Pop-up cards** have never been easier than with these new dies from Stampendous

#### Home sweet home 46

This **graduation party** will get top marks!

#### Parchment craft 54

Try something new with this **beginner project**

#### Colour clinic 66

Colour like a pro with **Chameleon Pencils**

#### 6 ways with VersaMark ink 73

There's so much to make with this **clear ink**

#### 10 minute makes 80

Try out new Craft Stacks from **Hunkydory**

#### The last word with... 98

**Leonie Pujol** as you've never seen her before

### More to make

#### Knowhow technique 26

Make imaginative and playful cards with Creative Expressions' **treat cups**

#### Quick makes 34

**12 easy cards** to make for all occasions

#### Bonus papers 48

Sarah Jackman Read has three gorgeous card ideas to make with your **free peacock papers**

#### 10 ideas for bird lovers 58

Take flight with these 10 **tweet ideas**

#### 1 sketch 3 ways 61

See Europe with **Stampin' Up!**'s new stamps

#### 5 ideas with windows 68

Ruth Hamilton has loads of creative ideas to try with **window frame dies**

#### Upcycle with... 83

Three pretty projects with **seed packets**



### 42 Masterclass pop-up cards



### 80 10 minute makes with Hunkydory



### 34 Quick makes 12 fab ideas



### 24 Something for the weekend die-cut floral wreath

### Subscribe today

**Subscribe today to take advantage of your exclusive digital edition subscription offer**

**Turn to page 32 now!**





## 46 Home sweet home graduation party

### Features

**Leonie's favourites** 56

Stamping fun with Leonie's **doodle designs**

**Crafting with Barbara Gray** 62

Summer florals with **Jayne Nestorenko** stamps

**Cardmaking around the world** 64

Meet Michelle Anders from **South Africa**

**Favourites** 79

We love bright and bold **summer stickers**

### Every issue

**Your letters** 6

See what's in **this month's postbag**

**Stampin' Up! competition** 13

**10 chances to win** a fantastic prize bundle

**The wish list** 14

Check out the latest **new craft products**

**The Hub** 70

All the latest from the **online world**

**Crafter's Q&A** 75

Our experts solve your **crafty dilemmas**

**Prize time!** 79

Over **£770 worth of goodies** to win!

**Puzzles** 85

Complete our **crossword** and win a prize

**Templates** 86

**All the templates** for this issue's projects

**Glossary** 93

**Cardmaking terms** made simple

**Toolbox** 94

Your guide to the **crafting essentials**

**Next month** 96

Take a look inside our **next issue**

### Where to buy

**Shopping guide** 91

Our handy **list of all the stockists** in this issue

**Back issues** 92

**Missed an issue?** Order it here

CARDMAKING & PAPER-CRAFT (USPS 250) is published bi-monthly (Jan, Apr, Jun, Aug, Oct and Christmas) by Immediate Media Company Bristol Limited, 2nd Floor, Tower House, Fairfax Street, Bristol BS1 3BN, UK. Distributed in the US by Circulation Specialists Inc., 2 Corporate Drive, Suite 945, Shelton, CT 06484. Periodical postage paid at Shelton, CT and other mailing offices. POSTMASTER: Send address changes to Cardmaking and Papercraft, PO BOX 37495, Boone, IA 50037-0495.



## 18 Knowhow stamping paper piecing

Make our cover star!



## 26 Knowhow stamping treat cup cards

## 58 10 ideas for bird lovers



## Your free gift!

### Mermaid Wishes



See page 10 for inspired ideas using your gift!

# Dear Sienna

Show off your cards and win a prize from Hunkydory!



"I love hearing your crafting stories and seeing your fab cards, so please write in and share them with me!"

**Sienna**  
Editor



Simple but effective!

## Endless possibilities

I had to share the card I made today using the stamps free with issue 169. I love how many possibilities there are! I decided to keep it fairly simple and stick to just a couple of colours, and only one little heart embellishment (which I coloured with my alcohol markers). Hope you like it, and thanks for another great issue.

**Fiona Fellows**, via email

**Sienna says:** *This is a really lovely card, Fiona. I think your decision to keep it simple has worked very well, I love the twine and little green heart, too. Well done, Fiona!*

## Inspiring issue

I wanted to share two of the cards I've made using the gorgeous bonus papers and toppers by designer Shannon McNab from issue 169. I look forward to my *Cardmaking & Papercraft* magazine arriving every month. I love looking through it as I always find fabulous inspiration. I hope you like my cards.

**Diane Felton**, via email

**Sienna says:** *Wow, these are so colourful and beautifully bright! What fantastic card creations for the summer months. Keep up the fabulous crafting, Diane.*

## Stage hand

As soon as I received my copy of issue 169, I knew I wanted to create and build a stage design of some kind using the free For All Seasons gift. I had great fun stamping the trees with the lovely coordinating leaves, hearts and flower blossom stamps. I used the embossing folders to create pretty little clouds, adding a little ink and glitter to emphasise the outline. I also wanted to make a feature of the hanging clouds, so I used cocktail sticks and added little bits of twine to make them look even prettier. Your sentiment stamps came in very handy, too, and I added the free papers included in the magazine. I do hope you like my creation.

**Justin Groves**, Leeds

**Sienna says:** *What a fabulous and inventive stage you've created. I love it! I really like the way you've outlined the clouds with glitter and placed the rabbits on different levels. This is so creative, Justin. Well done and keep crafting!*



**Editor's Favourite**

**Editor's Favourite wins £15 of Hunkydory goodies!**

## Comfort in crafting

I'd lost a bit of my crafting mojo after I experienced a miscarriage, but when my subscriber copy of issue 169 fell through my letterbox, I enjoyed flicking through so much that I got out my glues and inks again. I loved the tree stamps and found a sketch was the perfect way to show them off. I used the Tonic Studios

Woodland Walk papers as they complemented the stamps so well. Thank you for the gorgeous freebies, the inspiration and a reason to craft again.

**Michelle Dawson**, via email

**Sienna says:** *I'm so sorry to hear of your loss. I feel as though crafting and creativity really helps in times such as these. There is a real sense of calm to your make with the muted green, pink and yellow hues. It's a lovely card, Michelle. I hope you continue to find comfort in crafting.*

## Tree of love

I absolutely loved using the free For All Seasons stamp and embossing folder set free in issue 169! It is so versatile and I had so much fun using them! I really hope you like my card made using the stamp set.

**Beverly Coulton**, via email

**Sienna says:** *It is a really versatile set! I love how you've put the tree in a heart – it creates a very different look. How creative!*



**Be the first to send us a photo of a card you've made using this month's free cover gift and you could win a mystery craft prize!**



Butterfly heaven



Season of love...!



A trio of trees

**Terrific trio**

I was excited as always to receive my copy of *Cardmaking & Papercraft* in the post. The free gift is amazing with such versatility. A scene for all seasons, and the embossed clouds are a great addition to floral cards, too. I got to work straight away and wanted to share my makes with you as way of thanks. I look forward to trying out the letterpress technique!

**Fiona Bacon**, via email

**Sienna says:** *I love the three different backing papers you've used – they really complement the stamps. Three beautiful makes!*

**Delightful donation**

I've made three cards using the free stamps, which came with issue 169. I added my own papers and embellishments but had fun creating these scenes with the stamp set. I make lots of cards for the Dog's Trust, and these three will be donated, too. I loved the embossing folders, and I will definitely use them in other designs. Once again, thank you for a brilliant magazine and lovely free gifts and papers.

**Margaret S Browne**, Darlington

**Sienna says:** *These cards are fabulous, Margaret. You've managed to create a beautiful, coordinated collection. I love them! Thanks so much for sharing them with us.*

\*\*\*\*\*  
**Facing the facts!**  
 \*\*\*\*\*



A cardmaking challenge between two sisters

My sister and I FaceTime each other when we are cardmaking because I live on the south coast and she lives in the Midlands. We show each other the magazines we've bought and the great free gifts that come with them. Just before Easter, my sister showed me her copy of *Cardmaking & Papercraft* magazine, issue 168, which came with a lovely free gift of a bunch of spring flowers and two embossing folders. We decided to set each other a challenge to make a card for each other, and see how differently they would turn out using the same free gift. So, I rushed off to the shops to buy my own copy of the magazine, totally forgetting I had already purchased the magazine a few days before. I didn't mind though, as this meant I could emboss two

edges at once and had lots of bonus papers, too. Lucky me! My card is the lemon coloured one and my sister, Karen, made the green and silver card.  
**Vivienne Jane Westgarth**, Gosport

**Sienna says:** *I really love the idea of FaceTiming while cardmaking and discussing your craft magazines! And what a fabulous idea for a cardmaking challenge. I'm sure your sister will be surprised with your next FaceTime when you show her who's won the Star Letter in issue 171. I hope you both continue crafting, and FaceTiming!*



Star letter wins £50 of Hunkydory goodies!



Three is the magic number



**Not a subscriber yet?**

**Subscribe today to enjoy your digital edition subscription offer...**

**Turn to page 32 now!**



**Cardmaking & Papercraft**

Turn the page for more of your letters →

*Write to us and share your latest designs with us...*

Got a story to tell? Some tips to share? Send your letters and good quality photos to:  
**Dear Sienna**, Cardmaking & Papercraft, 2nd Floor, Tower House, Fairfax Street, Bristol BS1 3BN

Or you can email the team at [writetous@cardmakingandpapercraft.com](mailto:writetous@cardmakingandpapercraft.com)

**Every letter printed wins a £5\* craft prize from Hunkydory!**

\*Star Letter wins £50, Editor's Favourite wins £15 and Cardmaker on Holiday wins £15 worth of prizes.

Please include your full name, address and phone number/email address so that we can send you your prize. Only original letters will receive a prize. **Please note, your letters may be edited for reasons of space. We regret that cards cannot be returned.**





### Crafting therapy

We had a beautiful day in Calstock and I thought it was the perfect time to sit down with a cup of tea and read my copy of *Cardmaking & Papercraft* and have a go with the lovely free gift! My husband died a few months ago and I've been trying to find things to occupy me, so I thought I'd have a go at making cards. I really enjoyed it and it kept my mind occupied for a little while, too. Thank you for the great magazine. I'm already looking forward to the next issue.

**Anita Elliott**, Calstock

**Sienna says:** *Cardmaking, and crafting in general, is really therapeutic! I think it's because it keeps your hands and mind busy thinking about ideas and designs, and it's so lovely seeing the end result, too. I especially like how you've added sparkles to your card. It gives a really fun and cheerful feel to the finished card.*



## CARDMAKER ON HOLIDAY

### Indian adventure

We've always wanted to see the Taj Mahal, so my husband and I made sure that on our recent holiday to India the tour included a visit to this romantic place. I took my latest copy of *Cardmaking & Papercraft* magazine with me because I knew it would keep me interested and entertained on the long flight to Delhi. The vibrancy of the patterns and colours everywhere in India has inspired me to be more flamboyant with colours in my cardmaking. My early attempts with the free Lace

Bouquet embossing folder are showing great promise. Thanks for the inspiration from your lovely magazine.

**Vicky Holdway**, Stoke-on-Trent

**Sienna says:** *What a fantastic photo. I'm sure you came away with lots of inspiration that will be perfect for all your summer creations! It will be great fun introducing such vivid colours to your cardmaking, how exciting!*



Exotic inspiration



Cardmaker on Holiday wins £15 of Hunkydory goodies!

### Coping mechanism

My family and I are going through a particularly difficult time at the moment and my manager has been incredibly supportive in allowing me to put my family first. My crafting is invaluable to me as an escape from my troubles (as I'm sure it is for lots of us) and reading your magazine is a part of that escapism. The free gift that came with issue 169 inspired me to make this little token of appreciation for my manager, because without her support,

your magazine and my crafting, I would not be able to cope as well as I am! I have lots to be thankful for. I hope you like it!

**Tracey North**, London

**Sienna says:** *What a lovely card, and a lovely gesture, too! Crafting is a real escape for a lot of people, and it's such a pleasure to hear that Cardmaking & Papercraft magazine has helped you with your recent struggles. I'm sure your manager will be truly touched. I hope you keep up the wonderful crafting, Tracey.*



Craft your troubles away!

## CARDMAKING PRINCES

### Double act

I would like to nominate both my sons Henry (7) and George (5). My mother-in-law's lawn mower recently packed up, so for her birthday we got her a new one. My two little princes, Henry (left) and George (right) helped to make some garden-themed wrapping paper and matching cards using the free stamps from the May issue (169). They loved stamping the trees and birds, which made such pretty paper. Their nanny was so pleased with it.

**Hannah Harris**, Loughborough

**Sienna says:** *What a fantastic idea to not only make cards but also wrapping paper! I'm not surprised your nanny was pleased. Well done!*



The two kings of cardmaking!

### Win £10 of cool kids' craft goodies!

This issue's **Cardmaking Princes** win an exciting craft bundle from **Baker Ross**. Visit [www.bakerross.co.uk](http://www.bakerross.co.uk) for more inspiration!



To nominate your Prince or Princess, send a letter or an email plus a photo to: 'Cardmaking Prince or Princess', to the address, right.



Write to us and share your latest designs with us...

Send your letters and good quality photos to:  
**Dear Sienna**, Cardmaking & Papercraft, 2nd Floor, Tower House, Fairfax Street, Bristol BS1 3BN  
 or you can email the team at [writetous@cardmakingandpapercraft.com](mailto:writetous@cardmakingandpapercraft.com)

Every letter printed wins Hunkydory prizes

**NEW** Chameleon™ Color Tones Pencils

# Coloured Pencils you'll flip over!



**JUST  
FLIP TO  
BLEND!**



**SPECIALLY DESIGNED PENCILS  
WITH COLOURS PAIRED FOR  
PERFECT COLOUR BLENDS!**

- 50 COLORS/25 PENCILS
- ARTIST QUALITY/  
MADE IN AUSTRIA
- HIGHLY PIGMENTED  
INTENSE COLOURS!
- ULTRA SMOOTH  
CONSISTENCY
- PERMANENT
- PRE-SHARPENED
- BREAK RESISTANT  
3.8MM LEAD



**TRAVEL CASE ACTS AS A WORKSTATION!**

**CHAMELEON™**  
Changing Color.

# This month's free gift

## Mermaid Wishes

Find your inner mermaid, and take your cardmaking on an underwater adventure with your 3-in-1 gift set! **Fleur Pearson** has six gorgeous ideas to get you started...



Use your **FREE** 3-in-1 undersea collection to make inspired cards, gift tags and more!

**D**ive beneath the ocean waves and find a magical world of beautiful mermaids, charming seahorses, elegant shells and more with this month's free 3-in-1 gift. With 11 clear stamps, four designer papers and a wave border embossing folder, there's so much that you can create!

Designer Fleur has come up with lots of ways to use the stamps, from colouring them to match the purple, blue and turquoise of the patterned papers to stamping them onto coloured card and cutting them out to create 3D toppers. She's also shown just how versatile your mermaid stamp can be – you can colour her hair to match your recipient's, or even give her an on-trend, ombré 'sea-punk' look!

Perfect for summer, your Mermaid Wishes collection can also be used to make lovely nautical-themed cards. Try embossing patterns or borders with your wave folder, or building seaside patterns with the shell stamps. Or why not use the set to scrapbook a summer holiday at the beach?

We'd love to see what ideas you come up with for crafting with your 3-in-1 Mermaid Wishes collection, so please do share them with us using the contact information below – you could even win a mystery prize!



**Be the first past the post!**

Be the first to send us a photo of a card made using this month's free gift, and you could win\* a mystery craft prize!

*Win a prize!*

Email your photos to [writetous@cardmakingandpapercraft.com](mailto:writetous@cardmakingandpapercraft.com) or post your cards to **Cardmaking & Papercraft, Immediate Media Company Bristol Ltd, 2nd Floor, Tower House, Fairfax Street, Bristol BS1 3BN**

\*UK only. See p13 for full terms & conditions of entry

\*Gift available with print edition only

## Try these designs

### Mermaid wishes

- 1 Layer a 138mm square of net patterned paper onto yellow card, leaving a narrow border. Attach to a 150mm square white base card.
- 2 Stamp mermaid onto an 80x105mm piece of watercolour card. Colour with Distress Markers, and layer onto yellow card. Attach to base. Stamp sentiment onto yellow card, trim, and layer onto light blue card. Attach to base, using sticky fixers.
- 3 Stamp shells and starfish onto dark blue, light blue and yellow card. Cut out, shape and attach to base as shown, along with paper flowers.



### Make a splash!

- 1 Layer a 135mm square of purple shell paper onto a 140mm square of turquoise card. Layer a 95mm square of starfish paper onto a 100mm square of turquoise card. Attach panels as shown onto a 145mm square white base card.
- 2 Stamp the fish image onto a 65mm square of watercolour card, colour with Distress Markers, and layer onto a 70mm square of turquoise card. Attach to base, using sticky fixers.
- 3 Stamp sentiment onto a 70x20mm piece of watercolour card, layer onto turquoise card, and attach to base, using sticky fixers.

Turn the page for more ideas using your gift

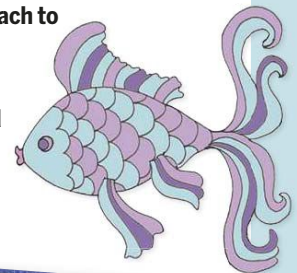

### Beautiful you

- 1 Attach a 90x60mm piece of coral paper and a 90x30mm piece of purple shell paper to a 95mm square of dark blue card. Stamp sentiment onto watercolour card, trim, layer onto dark blue card, and attach behind the top of the panel. Wrap panel with twine, and attach to a 100mm square white base card.
- 2 Use Distress Markers to stamp coral in purple and teal onto a 60mm square of watercolour card. Layer onto dark blue card, and attach to base with sticky fixers.
- 3 Stamp seahorse and shells onto watercolour card. Colour and cut out. Shape, and attach to base with sticky fixers. Add a small paper rose, to finish.



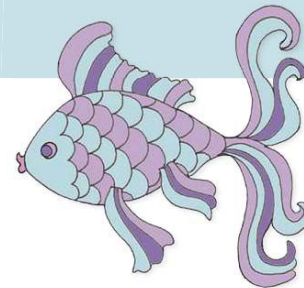

## More ideas with your free gift



### Stunning seahorse

- 1 Layer a 105mm square of seahorse paper onto a 110mm square of dark teal card, and attach to a 115mm square white base card.
- 2 Stamp seahorse as shown onto a 65mm square of watercolour card. Colour with markers and layer onto a 70mm square of dark teal card. Attach to base.
- 3 Stamp the sentiment onto an 80x10mm strip of watercolour card. Layer onto an 85x15mm piece of dark teal card, and attach to base as shown. Finish with black adhesive pearls.

### Magical mermaid

- 1 Layer a 120mm square of coral paper onto turquoise card, and attach to a 125mm square white base card.
- 2 Emboss a strip of teal Core'dinations card, and rub sandpaper over the raised wave design and distress the edges. Trim to 137x28mm, layer onto turquoise card, and add to base as shown.
- 3 Stamp mermaid onto a 73x105mm piece of watercolour card, colour and layer onto turquoise card. Add to base with sticky fixers. Mask part of the sentiment to stamp 'mermaid wishes' only onto watercolour card. Trim, layer onto turquoise card, and add to base with sticky fixers. Finish with pearls.



### Starfish kisses tag

- 1 Trim the top two corners of a 120x75mm piece of coral paper to make a tag shape, then layer onto a 125x80mm piece of yellow card, again trimming to a tag shape.
- 2 Stamp three starfish onto watercolour card, colour and cut out. Add to the tag as shown, using sticky fixers.
- 3 Mask part of the sentiment (using only 'starfish kisses') and stamp onto yellow card. Trim, draw faux stitching around the edges, and attach to bottom edge of the tag, as shown. Thread two buttons with yellow twine, tie in a knot, and attach to the top of the tag, to finish.



Free next month\*

Flower Fairies cardmaking pack  
See page 96

# 10 fabulous Stampin' Up! Petal Garden Suite prizes to be won!

Enter our competition and you could win this pretty Petal Garden Suite range from Stampin' Up! – including papers, stamps, inks and more!

Each prize worth over £100!



## How to enter

For your chance to win, simply answer the following question correctly:

**What colour do leaves turn in the autumn?**

- A) White
- B) Blue
- C) Orange

**Text** STAMP171 followed by your answer (A, B or C), then your name, postal address and email address to 87474\*. Texts will be charged at 50p plus your standard network tariff rate. The closing date for all entries is 11.59pm on Thursday 20th July 2017. For full terms and conditions please see below.

**Enter online** at our website [www.cardmakingandpapercraft.com](http://www.cardmakingandpapercraft.com)

**To enter by post** write your name, address and answer (A, B or C) on the back of a postcard and send to: Stampin' Up! Competition 171, Cardmaking & Papercraft, Immediate Media Co Ltd, 2nd Floor, Tower House, Fairfax Street, Bristol BS1 3BN

Get ready to craft with the beautiful Petal Garden Suite range from Stampin' Up!'s exciting new catalogue. This month we've got a fab chance for 10 lucky readers to win this sensational crafty range worth over £100. It contains all you need to make dozens of wonderful cards and pretty papercrafts.

Petal Garden Suite is a charming new collection from Stampin' Up!'s brand new catalogue, and is the perfect range to keep you cardmaking through summer. With deep burgundies, soothing greens and warm oranges in combination with soft, elegant blooms, you'll have so much fun crafting with this collection!

This impressive prize includes the Petal Garden designer papers, colourful card, a base card and envelope pack, an intricate embossing folder and matching embellishments, too. Plus, each winner will

receive the Graceful Garden six-piece rubber stamp set, which features a mix of gorgeous blooms, two thoughtful sentiments and geometric pattern stamp to choose from. Stampin' Up! has also added three of their bestselling ink pads and two clear stamping blocks to the prize bundle, too. To view the new catalogue visit [www.stampinup.eu](http://www.stampinup.eu).

### Each prize includes:

- ★ 1x Graceful Garden 6-piece Rubber Stamp Set
- ★ 1x Garden Trellis Textured Impressions Embossing Folder
- ★ 1x Designer Series Paper Stack
- ★ 1x Petal Garden Cardstock Pack
- ★ 1x Petal Garden Memories & More Card Pack
- ★ 4x Sheer Ribbon Sets
- ★ 3x Ink Pads
- ★ 2x Clear Stamping Blocks

**Promoter:** Immediate Media Company Bristol Ltd, UK and Channel Islands entrants only. Promotion excludes Immediate Media employees. By entering, you agree to be bound by all the rules of the promotion. Only one entry per person allowed. No responsibility accepted for lost, delayed, ineligible or fraudulent entries. Direct queries to [writetous@cardmakingandpapercraft.com](mailto:writetous@cardmakingandpapercraft.com) or call 0117 927 9009. Winning entries will be chosen at random from all eligible entries. Winners will be notified within 28 days of closing date. The draw is final and no correspondence will be entered into. For details of winners send an SAE within two months of the closing date. If any winner is unable to be contacted

within one month of the closing date, the Promoter will offer the prize to a runner-up. Promoter reserves the right to substitute the prize with one of the same or greater value but there is no cash alternative.

\* By entering this competition you are agreeing to receive details of future offers and promotions from Immediate Media Company Ltd and related third parties. If you do not want to receive this information please add the words 'NO INFO' at the end of your text message or write 'NO INFO' on your postcard.



### Whimsical watercolours

With idyllic blooms and romantic hues, Cocoa Vanilla's beautiful new Wild at Heart paper collection is a delight. Following the ever-popular watercolour trend, this collection has an array of charmingly soft, floral designs, dulcet tones and gently fused colours – and we adore it! Plus, if the pretty papers aren't enough, the gorgeous range of ephemera pieces might just push you over the edge with glee – the floral ampersand and dainty butterflies are just the cutest. You'll be creating summer card designs for your friends and family effortlessly with this fab collection.

**Cocoa Vanilla Studio Wild at Heart paper collection, from £1.19, [www.heylittlemagpie.com](http://www.heylittlemagpie.com)**

### Saving grace

Think pretty pastels, vintage florals and quaint designs, and you'll have Kaisercraft's Sage & Grace in mind. This oh-so dainty paper collection is the perfect companion for creating graceful and delicate cards this summer. With sweet polka dots, large and little blooms, paisley patterns and shabby chic papers to choose from, you'll have an exquisite selection of cards to show off. Perfect for sophisticated tea party invitations, elegant scrapbook pages or even an on-trend vintage birthday card!

**Kaisercraft Sage & Grace paper collection, £10.25, [www.merlyimpressions.co.uk](http://www.merlyimpressions.co.uk)**



### Ticket to ride

We love this adorable Bicycle Built for You stamp set from Lawn Fawn! With 28 pieces to choose from, this fun and versatile set will help you build an abundance of charming scenes that even Daisy Bell would approve of! Choose from a wonderful selection of accessories to build a bicycle just the way you want, with a top hat, beret, balloons, flowers, cat, dog, wedding veil and more. Plus, it comes complete with cute sentiments so you can create cards for every occasion – how perfect!

**Lawn Fawn Bicycle Built for You stamp set, £11, [www.sevenhillscrafts.co.uk](http://www.sevenhillscrafts.co.uk)**



Pick of the month



Pastel Lustre Vases, £39.95 [www.miafleurl.com](http://www.miafleurl.com)

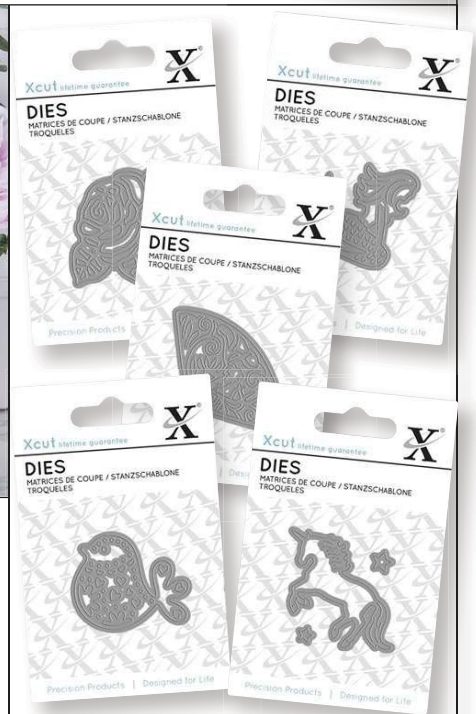

### Magnificent minis

Mini dies are on the rise, and docrafts have a fabulous selection to choose from. Ideal for creating your own decorative die-cuts, these wonderfully detailed Xcut dies will heat up your summer crafting. Choose from a gazing mermaid, prancing unicorn, ornate bird, pretty floral fan, a romantic rose and more. We love the idea of adorning your summer crafts with tiny mythical creatures – the perfect way to add a little magic and enchantment to your crafts!

**Docrafts Xcut Mini Dies, £2.75 each, [www.hobbycraft.co.uk](http://www.hobbycraft.co.uk)**

# The Wish List

It's all about summer colours with pretty pinks, luscious lilacs and tempting turquoises this month!

### Laws of attraction

Get ready to evolve your colouring skills with the exciting new Magnetips from The Fowndry. Featuring 20 high-quality, precision, fine-line, refillable colour pens, these are the most attractive new product to hit the colouring market. Plus, say goodbye to crafting clutter with Magnetips' help! Each pen has a powerful magnet within, so they'll stay attached together and ready for use. We're definitely feeling the pull towards this fabulous new product!

**The Fowndry Magnetips, £39.99, [www.thefowndry.com](http://www.thefowndry.com)**



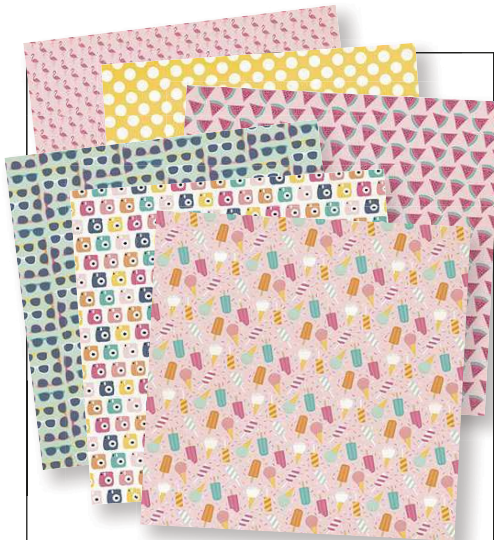

**She sells sea shells . . .**  
 Remember your holidays at the British seaside with the wonderful new Coastal Paper Stack from DCWV. Overflowing with nostalgic seaside memories, this fabulous paper collection will have you reaching for your flip flops and fish and chips. The luxurious collection includes 48 high-quality sheets, with 16 sumptuous papers featuring pearl foil designs. Each pack boasts pretty starfish, dazzling sentiments, stunning seashells and glamorous seaweed. Your marine crafting dreams and beach wishes will definitely come true with this fab set!

**Summer shades**

Get into the summer spirit with the wildly sunny and vibrant new Summer Dreams collection from Echo Park. The sensational paper collection is bursting with radiant designs, featuring delightful watermelons, on-trend flamingos, cool cameras, delicious ice lollies, zooming mopeds and more! This fantastic collection will whisk you away into dreams of sunshine, sunglasses, sun hats and fun. The set is perfect for documenting your summer holidays in a pretty scrapbook page, so pack your suitcase and start creating!

**Echo Park Summer Dreams paper collection, £16.50, www.craftie-charlie.co.uk**



**Trending now... Stripes**



Stripe Lemon Roll



Stripe Red Roll



Stripe Mint Blue



Stripe Magenta Roll



Stripe Lilac Roll

**Sprinkle twinkle**

Doodlebug is renowned for its fun and super cute crafting products, and these brand new Shape Sprinkles are just lovely. They're perfect for summer crafting with kids, and your little ones will have a fabulous time choosing between endearing ice creams, vibrant rainbows, cheeky monkeys and cheerful crocodiles! These wonderfully colourful and entertaining ephemera pieces will add just the right amount of playfulness to your crafting this summer!

**Doodlebug Shape Sprinkles, £5.49 each, www.craftie-charlie.co.uk**



**Mosaic moments**

Woodware has a fabulous new set of stamps on the market, and keen colourists are going to love them. The wonderful Mosaic Stamps are just waiting to be brought to life with a bit of colour and creativity, with a pretty heart, perching bird, crawling turtle and more to choose from. With beautiful images to make your own, these stamps are perfect for the expert and novice alike – simply get colouring and see where it takes you!

**Woodware Mosaic Stamps, £4.99 each, www.craftworldonline.co.uk**

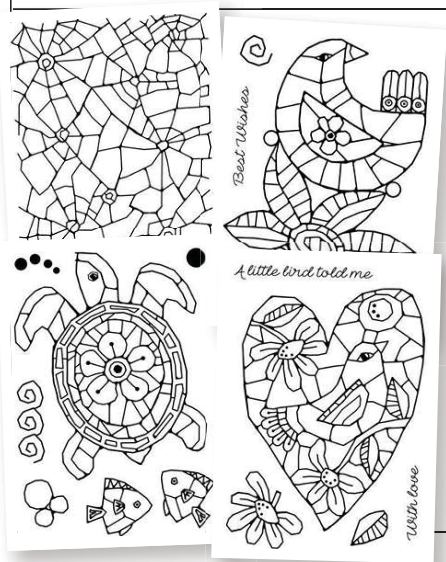

mt Masking Tape, £2.95 each  
[www.stonegift.com](http://www.stonegift.com)

## Trending now... Foliage dies

**Creative Expressions Sue Wilson Finishing Touches – Spring Foliage Die, £15.99**  
[www.craftworldonline.co.uk](http://www.craftworldonline.co.uk)

**Finishing Touches – Whimsical Leaves Dies, £7.95**

**Finishing Touches – Autumn Leaf Trio Dies, £15.49**

**Finishing Touches – Dandelion Posies, £7.95**

**Finishing Touches – Queen Anne's Lace, £8.45**

## What's on this month

### Crafting Live

**Doncaster Racecourse, Doncaster**  
**15-16th July**

Stephanie Weightman's award-winning Crafting Live is in Doncaster on the 15th and 16th July! So, get ready for a weekend of delight with fantastic exhibitors such as Tattered Lace, Crafty Devils and the exciting new Screen Sensation. Meet your favourite Create and Craft TV presenters and even book ahead to take part in one of the fabulous Make'n Takes that Crafting Live is renowned for. What are you waiting for? Adult tickets are £5.

**For more information and to book tickets, go to [www.craftinglive.co.uk](http://www.craftinglive.co.uk).**



### Exeter Craft Festival

**Exeter Cathedral Green, Exeter**  
**6-8th July**

The Exeter Craft Festival is a celebration of the very best artists and makers in the South West. Set in the picturesque grounds of Exeter Cathedral, the festival will take place between the 6th and 8th July. With over 100 stalls to peruse, you'll have plenty of opportunity to see what the West Country's best artists and crafters have to offer. A perfect outing for the whole family, with crafts, workshops, a Punch & Judy show, face painting, dancers and even a strolling jazz band. Admission is free.

**Visit [www.exetercraftfestival.co.uk](http://www.exetercraftfestival.co.uk) for more information.**

### Stitching, Sewing & Hobbycrafts Show

**NEC, Birmingham**  
**30th June-2nd July**

The Stitching, Sewing & Hobbycrafts show's next stop is the NEC in Birmingham, from 30th June to 2nd July, so get ready to stock up! The show is set to be a creative haven for all crafters, with plenty to see and do during the exciting three-day event. Enjoy inspiring workshops, demonstrations and talks, and all for no additional cost! Adult tickets are £8.

**Visit [www.ichfevents.co.uk](http://www.ichfevents.co.uk) for more details.**



### Charity crafts!

Stampin' Up! is celebrating its 10th anniversary in the UK, and to mark this special occasion they're asking all cardmakers to help them with their quest to give back to the crafting community. Stampin' Up! has a long history of supporting charitable causes and this year they're aiming



to make a whopping 10,000 cards over two crafting weekends, which will then be donated to the Ronald McDonald House Charities.

How can you get involved? The charity weekends are being held on the 23rd-25th June for the Birthday Wishes Challenge, and the 1st-3rd December for the Christmas Cheer Challenge. Get in touch with your local Stampin' Up! demonstrator to find out more, or go to [www.stampinup.eu](http://www.stampinup.eu).



# Living with joint pain?

## Our FREE guide can help

Filled with hints, tips and practical support, our free guide can help you cope with the aches and strains of joint pain.

When you call, we will ask for your delivery details. We will also tell you how you could support us with a donation, but there is no obligation to do so.

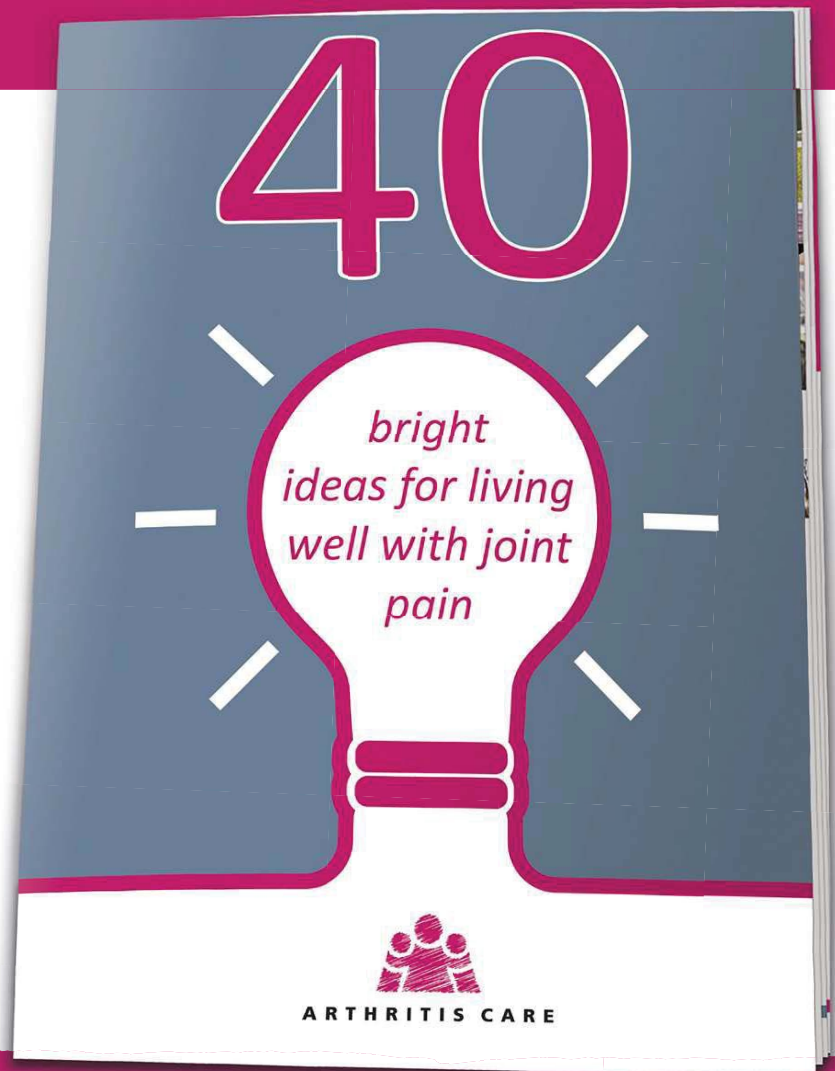

To request your free guide today, call

# 0800 144 5888



ARTHRITIS CARE



Registered Charity Nos. 206563, SC038693.



KNOWHOW

Paper  
piecing



# All dressed up

Add vibrant colour and pretty patterns to your stamped designs with paper piecing. **Paula Holfield** shows you how

Turn the page for your step-by-step instructions



## Cardmaking & Papercraft

### KNOWHOW

**Project:** Five cards and one matching tag

**Time:** 1 hour per card

**Expert:** Paula Holifield



Paula has been cardmaking for over a decade and is very much at home in her craft room, surrounded by pretty papers. A self-taught crafter, she enjoys everything from stamping and colouring to die-cutting and découpage. Paper piecing is one of her specialities, and she shares the secrets of this fab technique with you this month!



## KNOWHOW

### Paper piecing

Create perfectly coordinated cards by using paper piecing with your stamped designs

If you fancy trying something new with your stamping, then why not have a go at paper piecing? This is a simple yet effective technique that allows you to add extra dimension and colour to your stamped images and card designs. It allows you to bring together the colours of your backing papers and the stamped images on your cards for really striking results.

Paper piecing basically means stamping onto a solid background and then again onto coloured or patterned paper, and cutting parts of the second stamping out to place onto the original stamped image. This works especially well for clothing, rather than colouring in the clothes.

It's a technique that I enjoy and I use a lot. It can really liven up your card designs – so why not try it out today?!

### Shopping list

Pink Paislee Oh My Heart 12x12 papers, £18.69; Pink Paislee Oh My Heart Charms, £5.49

From **Craftie-Charlie**

Little Darlings Rubber Stamps: Prosecco Time, Time to Sparkle, £9.75 each; All Dressed Up, £10.99

From **Crafteezee**

Die-cutting machine: circle, pierced circle, scalloped circle, oval, pierced square and pierced rectangle dies; pink card, black card, ribbon, baker's twine, border punch, paper flowers, sparkly gems, enamel dots, alcohol markers, buttons, sentiment toppers and stamps

From your local craft shop

For stockists turn to page 91

Cute and colourful Oh My Heart is perfect for paper piecing!



## How to make this card and tag



**1** Layer a 135mm square of spotty paper onto a 140mm square of black card. Cut two 45x115mm pieces of pink paper and layer each onto black card. Add to the upper left and lower right of the spotty panel as shown.



**2** Wrap the black ribbon around the centre of the panel, and attach it to a 145mm square white base card. Layer a 95mm white circle onto a larger scalloped circle of black card. Add to the base card with sticky fixers.



**4** Stamp image again onto spotty paper and cut out just the dress. Colour the bow, and attach dress onto your first stamped image. Cut around image, leaving a small border. Add to base with sticky fixers.



**5** Stamp or print a sentiment onto white card and layer onto black card. Add to the right side of the base with sticky fixers. Attach a few layered paper flowers and add a sparkly gem to the centre, to finish.

## Now try these



Use paper piecing to add pretty patterns to stamped images

### With love

**1** Die-cut a 135mm square of white card with a pierced border, and layer onto a 140mm square of pink card.

**2** Layer a 120x55mm piece of spotty paper onto 125x65mm of pink card and a 55x140 piece of floral paper onto 60x140mm of pink card; add to panel as shown. Wrap panel with pink ribbon. Attach to a 145mm square white base.

**3** Add a plain white oval to the second largest Elegant Oval die-cut from pink card. Add this to

the centre of the base with sticky fixers. Stamp image onto white card, and colour everything but the dress. Stamp image again onto floral paper and pink paper. Carefully trim the bodice and skirt from the floral paper and the belt from the pink paper. Add these to the first stamped image. Trim around the image and add to the oval with sticky fixers.

**4** Finish with a sentiment and flower shaped buttons threaded with baker's twine.

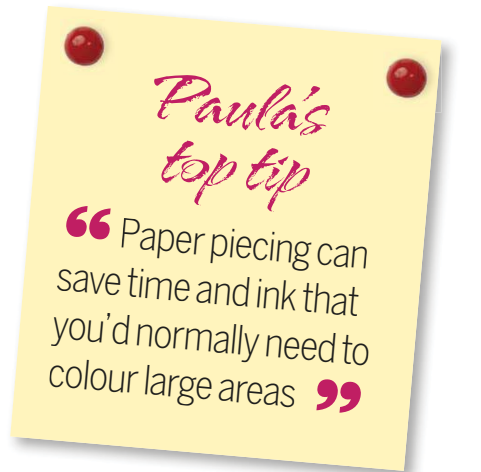

### Paula's top tip

“Paper piecing can save time and ink that you'd normally need to colour large areas”



**3** Stamp the Prosecco Time image with black ink onto white card and colour in the hair, face, body, gloves, shoes and prosecco glass with alcohol markers. However, you will not have to colour in the dress on this stamped image.



**6** Layer 50x90mm pink tag onto black then white card. Add a strip of spotty paper layered on black card. Stamp image, cut with small circle die and colour. Add to black scalloped circle. Add sentiment and ribbon.



Simple designs can be very elegant!

### So special

**1** Stamp image onto the right-hand side of a 115mm square of white card with a pierced border. Colour the hair, skin and shoes, then layer the card onto a 120mm square of pink card. Attach this to a 140mm square of aqua script paper.

**2** Wrap the left-hand side of the panel with pink and white baker's twine, and attach to a

145mm square white base card. Stamp two sentiment tags onto white card, cut out and add to the top of the twine with a twine bow. Secure in place with a sticky fixer.

**3** Stamp the image again onto plain aqua paper. Carefully cut out the dress, and attach it on top of the first stamped image, to finish.

Turn the page for Paula's top tips





## KNOWHOW

### Paper piecing

## Happy birthday

**1** Layer a 95x135mm piece of white card with a pierced border onto a 100x140mm piece of pink card. Add two thin strips of heart paper to either side of the panel as shown, and attach to a 140mm square white base card, using sticky fixers.

**2** Trim an 85x50mm piece of heart paper to a pennant shape and layer onto pink card. Attach to the base as shown.

**3** Die-cut a 90mm pierced circle and cut in half. Layer this onto a slightly larger circle of pink card which has also been cut in half. Attach to the base card, over the pennant shape as shown.

## Two more designs to try

Paper piecing gives this tutu added dimension



**4** Stamp image onto white card and also onto light pink paper. Colour everything but the dress on the main image. Cut out the dress from the pink paper and add to the first image. Trim image, and add to base with sticky fixers. Add enamel dots and a sentiment, to finish.

## Paula's top hints & tips

Follow Paula's expert advice on paper piecing



★ Some stamps will work much better with this technique than others – avoid small, very detailed stamps to avoid lots of fussy cutting and tiny pieces.

★ Use a darker ink colour to stamp your images, as you'll want to see the lines clearly for cutting.

★ Paper piecing tends to work best with stamps with larger areas to cut out. It's perfect for large areas that would otherwise take a very long time and a huge amount of ink to complete!

★ Avoid using very dark papers or patterned paper with lots of dark areas, as it will be difficult to see the ink lines for cutting.

★ This technique works just as well for digital images as well as traditional stamped images. I print onto plain paper and then tape down what patterned papers I want to print on in the same position onto plain paper. Then I just cut out the patterned papers and attach as normal.

★ Do use a sharp craft knife for any fussy cutting that would be difficult with scissors.

A craft knife will help you cut detailed areas



## Celebrate

**1** Attach a 135x100mm piece of floral paper and a 135x35mm piece of white card to a 140mm square of pink card.

**2** Cut a 100x70mm piece of heart paper and layer onto a 105x75mm piece of pink card. Attach this to the centre of the first panel as shown. Punch along the bottom of a 145x40mm strip of pink card, and add a 140x30mm strip of green paper to the centre before attaching to the first panel to cover the join between the floral and white card. Wrap with baker's twine, and attach to a 145mm square white base card.

**3** Cut a 10x50mm piece of white card and layer onto pink card. Attach to the right-hand side of the base with sticky fixers.

**4** Stamp the image onto white and then pink card. Colour the hair, skin, shoes and inside

The inside of this dress is coloured, and the front is paper pieced!



of the dress. Trim the front of the dress from the pink card, and attach on top of the first image. Trim around image, and add to base with sticky fixers. Add a heart charm and sentiment, to finish.

Next month  
Mirror stamping



# The original and multi-award winning TV Craft channel

Sky 674 Freeview 23 Virgin 748 Freesat 813 Apple TV & Amazon Fire



Martyn Parker



Rachel Pierman



Dean Wilson

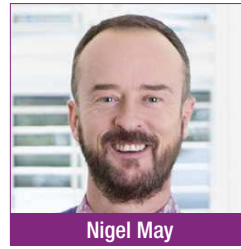

Nigel May



Jenny Cleary



Dan Bancroft



Stephanie Weightman



Mel Heaton



Ben Moseby



Loen Love



Andy Love

Meet the Create and Craft family

# Watch, learn and be inspired with Create and Craft



**Sky 674, Freeview 23, Freesat 813, Virgin 748**

*WATCH*



[createandcraft.com/cmpc](http://createandcraft.com/cmpc)

*SHOP*



**0330 0415 684\***

*ORDER*



*FOLLOW*

\* Calls cost 20p per minute plus network extras. Calls from mobiles and other networks may cost more. Create and craft is a registered trading name of Ideal Shopping Direct Limited. Registered in England No. 1534758. VAT No. GB 738 1640 28. Registered Office: Ideal Home House, Newark Road, Peterborough PE1 5WG. Information accurate at time of printing.

SOMETHING *for*  
the WEEKEND



# Pretty as a posie

Welcome summer with Florartisty dies and **Sharon Callis'** show-stopping wreath inspiration for your home

# Sharon's top hints & tips

Make a summer floral wreath with Sharon's expert advice



★ Instead of crêpe paper to cover the wreath you can also use fabric, felt, hessian or simply paint.

★ When forming the centre stamens and using gems or buttons, you can adjust the stamen size. Measure the diameter of the gem and adjust the stamen accordingly.

★ You can mix materials when forming the flowers – why not try vellums for the centres to add a delicate touch?

★ Add texture to your petals by dry embossing the die-cuts before forming your flowers.

★ The folding dies work best when using double-sided papers to save time on gluing and assembly. However, if you are using single-sided papers, simply cut along the perforated line, turn over one of the strips, layer over the other and glue in place.

## Shopping list

Floristry: Stamen Dies, £5.99 each; Fabulous Foliage Dies, £6.99-£7.99 each; Floral Finishers Dies, £8.99-£9.99 each; Small Floral dies, £8.99-£9.99 each; Large Floral dies, £11.99-£12.99 each

### From Personal Impressions

Die-cutting machine, hot glue gun, quilling tool, 10" foam ring, green crêpe paper, hanging loop, coloured card, pearls

### From your local craft shop

For stockists turn to page 91

## How to make a floral wreath



**1** Die-cut the Traditional and Universal Stamens. With a quilling tool, make a tight coil with the Traditional Stamen, and wrap the Universal Stamen around the outside. Leave on the quilling tool.

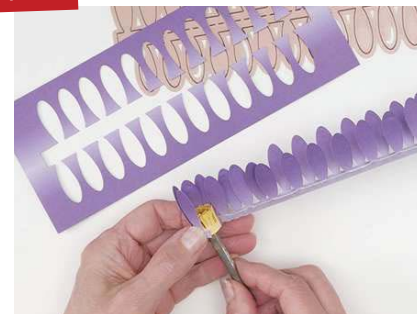

**2** Die-cut a Fabulous Folding Flower and fold along the perforated centre line. Add glue along the folding strip and wrap the flower around the stamen on the quilling tool. Remove from the quilling tool.



**3** Die-cut the Floral Finisher from green paper and glue to the base of the flower. Fold the edges up around the flower base. This will hold your stamens and flower petals in place.



**4** Add a Fabulous Foliage die-cut to the base and a pearl, button or gem in the centre to finish. Repeat to make flowers using different paper colours and petal shapes. Add leaves to the larger flowers.



**5** Cover a polystyrene wreath base with 30-40mm wide strips of green crêpe paper. Wrap around the wreath base overlapping slightly and secure with glue at the end.



**6** Add greenery to the base with various Fabulous Foliage die-cuts. Start on the outside edge and work in a clockwise direction adding pieces around the outer edge of the wreath. Repeat on inner edge.



**7** After making plenty of flowers, glue to the wreath base with a hot glue gun or silicone glue. Work in a clockwise direction, sticking them close together and mixing the colours, shapes and size attractively.



**8** Continue until you have filled the whole wreath with flowers, adding more foliage if necessary. Attach a hanging loop to the reverse, spray with a lovely scent, and your floral wreath is ready to hang.



KNOWHOW

Treat cup  
cards

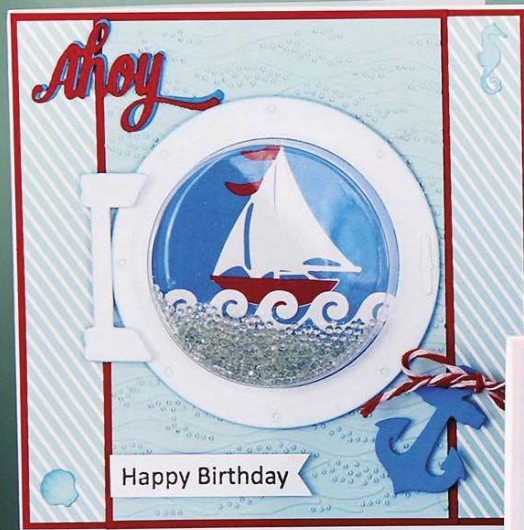

# Shake it up!

Fill your cards up with fun, using **Sue Hughes'** design inspiration and Creative Expressions' new treat cups and dies!

# Cardmaking & Papercraft

## KNOWHOW



**Project:** Five cards and one matching tag

**Time:** 1 hour per card

**Expert:** Sue Hughes

Sue is an experienced cardmaker, having been cardmaking and papercrafting for over 15 years. She's always loved anything and everything crafty, and this month she's made fabulous cards using Creative Expressions' treat cups! These cups take shaker cards to a whole new level and Sue has gotten creative with her design inspiration.



Turn the page for your step-by-step instructions





## KNOWHOW

### Treat cup cards

Create some oh-so-fun shaker cards with Sue Hughes' brilliant treat cup card ideas and inspiration

If you enjoy creating 3D shaker cards or have wanted to have a go at it, then you'll love using these treat cups. Their clever design makes it easier and quicker than ever to create unique interactive cards that are sure to put a smile on the recipient's face!

Simply fill the cups with sequins, glitter, microbeads, die-cut shapes or whatever you desire – the possibilities are endless. As the cups are robust, you can add bigger and heavier fillers, and because they are deep, the contents will have more room to shake, too!

The Creative Expressions treat cups and die-sets used here are specifically designed to work together so you don't need to worry about fiddly cutting and measuring.

### Shopping list

Creative Expressions Fillables: Porthole, £12.49; Fish Bowl, £9.99; Fluttering Heart, £9.49; Laced Heart, £9.49; Nautical Accessories, £9.99; Creative Expressions Treat Cups: domes and hearts, £2.79 each; Creative Expressions Clear Stamp Set: Sweet Wishes, Fishbowl Friends, £10.49 each; Creative Expressions Embossing Folder: Ocean Waves, £5.49

**From Joanna Sheen**

My Favorite Things: Hearts and Stripes 6x6 papers, £5.95; Sweet Celebrations 6x6 papers, £5.95

**From Seven Hills Crafts**

Die-cutting machine, scalloped circle nesting dies, scalloped rectangle nesting dies, scalloped square nesting dies, circle nesting dies, foliage dies, butterflies dies, heart punch, acetate, Tumbled Glass Distress Ink, pink ink, coloured card, pearls, gems, sequins, microbeads, hand sanitiser, ric-rac, ribbon, googly eyes

**From your local craft shop**

**For stockists turn to page 91**

## How to make the card and tag



**1** Layer a 140mm square of pink heart patterned paper onto a piece of white card and a piece of blue card. Attach to a 150mm square white base card with the fold at the top for extra stability.



**2** Sprinkle a selection of sequins into a heart shaped treat cup. Cut a circle of acetate and place it on top, securing with glue or double-sided tape to hold the sequins in the treat cup.



**4** Die-cut the heart dies from white card. Attach the butterfly background heart to pink card and add to the reverse of the aperture. Add the heart frame over the treat cup. Attach to base with sticky fixers.



**5** Stamp a sentiment onto white card, trim to size and layer onto blue card. Attach to base using sticky fixers. Die-cut four white butterflies, brush with ink and attach. To finish, add pearls to the corners.

## Now try these

### Just for you

**1** Layer a 140mm square of pink striped paper onto blue card and pink card. Attach to a 150mm square base. Layer a 115mm square of plaid paper onto pink card and use the fish bowl circle die to cut an aperture. Add ric-rac.

**2** Place coins into a treat cup and secure with acetate. Push through the aperture, add a piece of pink card to the reverse then attach to base.

**3** Die-cut the fish bowl frame from pink card, trim one side to create a more circular shape at the top, then stick in place around the treat cup with the straight edge at the bottom. Add two upside down pink hearts for the pig's feet. Curl a strip of pink card around a pencil for the tail and attach.

**4** Die-cut a 55mm pink circle, cut shapes for the ears and attach in place. Cut a 25mm circle from light pink card for the nose, add two small circles and

Get creative with your dies to make new shapes!



attach with sticky fixers. Add two googly eyes and attach to the top left of the treat cup. Stamp a sentiment onto white card, trim to a pennant and layer onto blue card. To finish, attach sentiment to the top right corner of the base.

Turn the page for Sue's top hints & tips



### Best fishes

**1** Attach a 145mm square of red card to a 150mm square white base. Layer a 135mm square of blue striped paper onto a white scalloped square. Layer a 135x35mm piece of plaid paper onto white card with the lower edge cut with a reverse scallop. Use the circle from the fish bowl set to cut an aperture 30mm from the bottom edge.

**2** Pour hand sanitiser gel into a round treat cup so until it is two thirds full. Glue a piece of acetate on top to seal. When the glue is dry, push cup through the aperture.

**3** Stamp pebbles onto white card and colour with pencils. Add two die-cut water weeds. Stamp, colour and cut out two fish and attach above the pebbles. Place panel under the aperture and attach to the base card. Die-cut a fish bowl frame from red card and attach over the treat cup.

**4** Stamp a sentiment onto white card, trim to a pennant and layer onto red card. Attach to the top left corner with

Add hand sanitiser to create a water-effect



sticky fixers. Die-cut starfish and shells from pink and yellow card and brush with pink ink. Place in a pattern along the scalloped border. Add a shell and starfish to the top right corner and a seahorse to the sentiment panel. Finish with gems.

### Sue's top tip

“ Be sure to use a thick base card and turn it so the fold is at the top to stop it falling over ”



**3** Layer a 110mm circle of blue patterned paper onto a white scalloped circle. Cut an aperture using the heart from the Fluttering Heart die set. Push the treat cup through the opening and secure on the reverse.



**6** For the tag, layer blue paper onto a scalloped rectangle. Place sequins in the treat cup, seal with acetate and push through aperture. Add frame, layer onto pink and white card. Add ribbon, butterfly and sentiment.



KNOWHOW

## Treat cup cards

### Great friend

**1** Layer a 135mm square of blue hearts patterned paper onto a white scalloped square and a 145mm square of pink card. Attach to a 150mm square white base card.

**2** Layer a 95x135mm piece of pink striped paper onto white card. Use the heart die from the Laced Heart set to create an aperture. Sprinkle a selection of die-cut flowers into the treat cup and secure a piece of acetate on top. Push cup through the heart aperture.

**3** Die-cut the background and frame from white card. Attach to a piece of blue card and place underneath the aperture. Add the panel to the base card and stick the die-cut frame around the heart. Stamp a sentiment onto white card, layer onto blue card, and attach with sticky fixers near to the bottom of the base card.

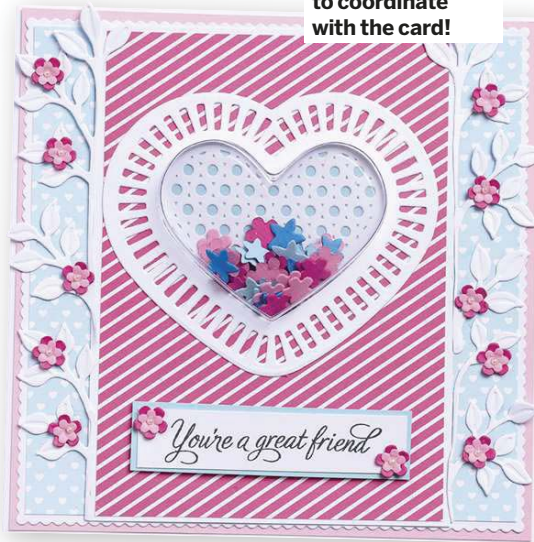

Use a die-cut filler to coordinate with the card!

**4** Die-cut foliage from white card, trim and attach to base along either side. Die-cut light pink and dark pink flowers, layer together and attach as shown. To finish, add pearls.

## Sue's top hints & tips

Sue has put together some handy pointers to help you get the most of your treat cup cards



★ You can use glue or double-sided tape to secure the acetate to the treat cup. If your contents are small, it's better to use glue to ensure a tighter fit and prevent the contents from leaking. Ensure you allow plenty of time for the glue to dry – the fishbowl card, shown here, was left to dry for two days.

★ Take care if using glue, as the acetate can easily slip out of place. It's a good idea to secure it with tape and try not to spread the glue too near to the inside edge of the treat cup as it may show through when the acetate is placed on top.

★ If you are using a heavy filling or have lots of embellishments, use a thick base card and turn it so the fold is at the top to stop it falling over.

★ Layer your backing paper onto card before cutting the aperture to give it more stability.

★ If you don't have dies the correct size or shape, simply draw around the inside edge of the treat cup and carefully cut out the aperture with a craft knife.

### Ahoy

**1** Layer a 140mm square of blue striped paper onto red card and attach to a square white base card. Emboss a 95x140mm piece of blue card with a wave pattern and layer onto red card. Attach to base centrally.

**2** Die-cut the Porthole frame from white card and brush with blue ink. Push a round treat cup through it. Add clear microbeads to the treat cup and cover with a circle of acetate slightly smaller than the porthole frame to secure the beads.

**3** Die-cut a blue circle slightly smaller than the porthole frame. Add die-cut waves and a boat cut from white card with elements cut from red card. Place underneath the porthole and attach to the centre of the base. Cut the porthole hatch from white card, brush with ink and attach to the left of the porthole with sticky fixers.

**4** Stamp a sentiment onto white card, trim one end to a pennant and attach underneath the porthole. Thread baker's twine through a blue die-cut anchor and attach near to the bottom right corner. Die-cut 'ahoy' from red

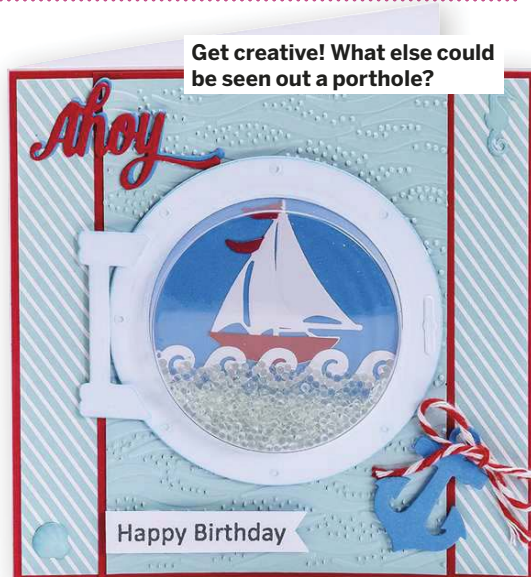

Get creative! What else could be seen out a porthole?

card and blue card. Layer together, offsetting them slightly and attach in the top left corner. Add a die-cut shell and seahorse to the other corners to finish.



Treat cups can be loads of fun for your cards!



# Make *Amazing* Cards

*Bumper pack*



ORDER TODAY!

Your complete summer cards kit worth **£20** & featuring **219 pieces!**

Your bumper pack includes:

- ✓ 2 embossing folders
- ✓ 15 stylish stamps
- ✓ 32 designer papers
- ✓ 12 découpage sheets
- ✓ 85 toppers & motifs
- ✓ 72 all-occasion greetings

PLUS an inspirational project magazine packed with ideas for amazing cards and crafts to make for all occasions!



**NEW!**

COMPLETE CARDS KIT FOR SUMMER Worth **£20!**

only **£8.99** inc p&p

## Make *Amazing* Cards

Summer 2017 Special issue £8.99

*Bumper pack*

**219** PIECE GIFT SET  
Amazing cards to make for every occasion!

- INSIDE YOUR PACK:
- ✓ 32 designer papers
  - ✓ 12 découpage sheets
  - ✓ 85 toppers & motifs
  - ✓ 15 stylish stamps
  - ✓ 72 all-occasion greetings
  - ✓ 2 embossing folders
  - ✓ Project magazine

**3** fantastic gifts

GIFT 1  
15-piece stamp set

Turn over for more

GIFT 2  
2 embossing folders

GIFT 1  
15-piece stamp set

GIFT 2  
2 embossing folders

GIFT 3  
Stylish papers, toppers & découpage

Fab card ideas, step-by-step guides & e

**ORDER YOUR COPY NOW!**

CALL ☎ 0844 844 0388 and quote 'Make Cards Summer 2017'

ONLINE [www.buysubscriptions.com/craftspecial](http://www.buysubscriptions.com/craftspecial)

Lines open weekdays 8am to 8pm and Saturday 9am to 1pm. Overseas please call ☎ +44 (0) 1795 414 676.  
EUR price £11.99, ROW price £12.99. All prices include p&p.

# Cardmaking & Papercraft

Save when you subscribe  
To the digital edition



Available from



Available on the  
**App Store**



GET IT ON  
**Google play**



Available on  
**kindle fire**

The perfect addition to your crafting, featuring the very best techniques, detailed step-by-steps, essential advice and knowhow from the top experts and gorgeous card and papercraft ideas from all your favourite designers.



Enjoy our Premium App experience now available from



Cardmaking  
& Papercraft

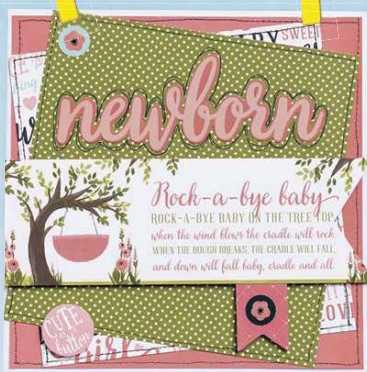

**12 QUICK PROJECTS**  
to make today

# Quick makes for July

Make pretty cards for babies, birthdays, summertime fun and more, with 12 inspiring ideas from our designers

## This month's designers

### Lisa Plummer



This month, Lisa has used the fabulous new Portrait of a Lady collection from Graphic 45 to make a set of four elegant vintage cards, perfect for any occasion year-round.

### Jo Nevill



Jo is showing off her cat-itude with My Mind's Eye cat-inspired Meow collection. You'll love the precious feline figures and the fresh modern makes Jo has in store for you!

### Tracey Grundy



Tracey has used the lovely Rock-a-bye Baby Girl collection from Carta Bella this month. It's full of gorgeous pastels, charming nursery rhymes and the cutest little characters.



Happy birthday



Portrait of a lady

Turn the page for your step-by-step instructions



Rock-a-bye baby



Great friend



Lovely lady

## Portrait of a lady

**1** Ink the edges of a 130mm square of Kraft card and attach to a 135mm square base card. Ink the edges of two 130x55mm pieces of contrasting patterned paper. Attach to base as shown. Add a ribbon and a border from the paper pad over the join.

**2** Cut out a lady topper from the paper pad, ink edges and attach with sticky fixers. Add a message tag to the top left, and a chipboard square on top.

**3** Ink the edges and attach three circle embellishments and a rose banner, as shown.

**4** To finish, tie a twine bow and add to the banner at bottom left.



### Shopping list

Graphic 45 Portrait of a Lady: 8x8 paper pad, £10.95; Decorative Chipboard, £5.45; Journalling Chipboard, £5.45  
**From Charmed Cards & Crafts**

Kraft card, Vintage Photo Distress Ink, cream satin ribbon, twine

**From your local craft shop**

For stockists turn to page 91

Just a little note

## Happy birthday

**1** Layer a 130mm square of fish bone patterned paper onto a 135mm square of white card, and attach to a 140mm square grey base card.

**2** Attach a 135x45mm strip of patterned paper and a 135x25mm strip of striped paper, as shown. Add a swirl of twine to the base, securing the ends with a small piece of tape.

**3** Stamp a sentiment onto a speech bubble in black ink. Stamp and heat emboss 'Happy Birthday' in white onto black paper and die-cut into a pennant. Attach to base using sticky fixers.

**4** Attach die-cut pieces from the mixed bag using sticky fixers and double-sided tape. To finish, add a puffy sticker.



### Shopping list

My Mind's Eye Meow: 6x6 paper pad, £5.99; Mixed Bag, £5.99; Puffy Stickers, £4.99

**From Hey Little Magpie**

My Favorite Things Fishtail Flags Stax Dies, £15.95; Hero Arts Many Everyday Messages Clear Stamp Set, £12.95

**From My Mum's Craft Shop**

Die-cutting machine, heat tool, grey card, black twine, VersaMark ink, white embossing powder

**From your local craft shop**

For stockists turn to page 91

Design by Lisa Plummer

Design by Jo Nevill

Coy kitten

## Great friend

**1** Attach two 100x130mm pieces of patterned paper overlapping at an angle to a 140mm square white base as shown.

**2** Round the corners of a 125x90mm piece of patterned paper and attach to base. Die-cut a tag from patterned paper and tie a twine bow to the top. Attach using sticky fixers.

**3** Stamp a sentiment onto pink patterned paper and die-cut to create a pennant. Attach to base using sticky fixers. To finish, attach die-cuts from the mixed bag using sticky fixers and double-sided tape. Add a puffy sticker, to finish.



### Shopping list

My Mind's Eye Meow: 6x6 paper pad, £5.99; Mixed Bag, £5.99; Puffy Stickers, £4.99

**From Hey Little Magpie**

My Favorite Things Fishtail Flags Stax Dies, £15.95; Hero Arts Many Everyday Messages Clear Stamp Set, £12.95

**From My Mum's Craft Shop**

Die-cutting machine, tag die, corner punch, black twine

**From your local craft shop**

For stockists turn to page 91

Dream big

## Rock-a-bye baby

**1** Cut two 110mm squares, two 120mm squares and two 130mm squares of contrasting patterned papers. Cut each square in half diagonally to create triangles. Layer contrasting triangles together and attach to a 140mm square white base card, as shown. Draw a faux stitching border.

**2** Trim the rocking horse paper to 75mm square, and layer onto patterned papers. Attach to base with sticky fixers.

**3** Add 'Dream Big Little One' sticker to base and outline with a black fineline pen. Add ephemera sentiments, to finish.



### Shopping list

Carta Bella Rock-a-Bye Baby Girl 12x12 Collection, £16.49

**From Craftie-Charlie**

Black fineline pen

**From your local craft shop**

For stockists turn to page 91

Design by Jo Nevill

Design by Tracey Grundy



Cat-itude!



Welcome

Turn the page for your step-by-step instructions



New arrival



Believe in yourself

Pretty pastels

## Welcome

**1** Attach a 130mm square of pink patterned paper to a 140mm square white base card using sticky fixers. Layer a 120mm square of patterned paper onto white card with a pierced border. Attach to base and add corner tabs cut from patterned paper.

**2** Layer a 130x20mm strip of patterned paper onto a 130x40mm piece of white card. Pierce a border around the edges and attach centrally.

**3** Add an 'I love you' tab and green pennant to the reverse of the baby girl topper. Pierce a border around the edges and attach to base using sticky fixers.

**4** To finish, add a small flower to the bottom left corner.



### Shopping list

Carta Bella Rock-a-Bye Baby Girl 12x12 Collection, £16.49

**From Craftie-Charlie**

Needle or piercing tool

**From your local craft shop**

**For stockists turn to page 91**

Design by Tracey Grundy

Just purr-fect

## Cat-itude!

**1** Die-cut two pennants from coordinating patterned papers and attach to the centre of a 140mm square grey base card.

**2** Round the corners of a 100x90mm piece of patterned paper. Attach centrally.

**3** Die-cut a tag, tie with a twine bow and add to base using sticky fixers. Attach the die-cuts from the mixed bag using double-sided tape and sticky fixers. Add a couple of puffy stickers to finish.



### Shopping list

My Mind's Eye Meow: 6x6 paper pad, £5.99; Mixed Bag, £5.99; Puffy Stickers, £4.99

**From Hey Little Magpie**

My Favorite Things Fishtail Flags Stax Dies, £15.95

**From My Mum's Craft Shop**

Die-cutting machine, tag die, grey card, black twine

**From your local craft shop**

**For stockists turn to page 91**

Design by Jo Nevill

Vintage florals

## Believe in yourself

**1** Layer a 125mm square of rose paper onto a 130mm square of Kraft card. Ink the edges and attach to a 135mm square base.

**2** Layer a 120mm square of pink patterned paper onto Kraft card and ink the edges. Add taupe ribbon down both sides as shown and add to base.

**3** Layer a 120x75mm piece of brown striped paper onto Kraft card, ink the edges and attach to base. Add a lady tag to left as shown.

**4** Attach a chipboard frame over a second lady image, trim around and add to base. To finish, attach a sentiment with sticky fixers and a chipboard label to top.



### Shopping list

Graphic 45 Portrait of a Lady: 8x8 paper pad, £10.95;

Decorative Chipboard, £5.45;

Journalling Chipboard, £5.45

**From Charmed Cards & Crafts**

Kraft card, taupe ribbon, Vintage Photo Distress ink

**From your local craft shop**

**For stockists turn to page 91**

Design by Lisa Plummer

Baby girl

## New arrival

**1** Attach a 135mm square of striped paper to a 140mm square white base card.

**2** Attach a 130mm square of patterned paper at an angle, as shown. Draw a border with a black fineline pen.

**3** Trim the nursery rhyme paper to a 150x50mm pennant and attach as shown. Add a 50x20mm pink triangle from patterned paper on the bottom right, and draw a border.

**4** Add 'girl' sticker to base and ephemera using double-sided tape and sticky fixers, to finish.



### Shopping list

Carta Bella Rock-a-Bye Baby Girl 12x12 Collection, £16.49

**From Craftie-Charlie**

Black fineline pen

**From your local craft shop**

**For stockists turn to page 91**

Design by Tracey Grundy



Beauty begins



I love cats

Turn the page for your step-by-step instructions



Newborn



Elegance



For a cat person

## I love cats

**1** Cut one 125mm square from grey card and one from black and white lined patterned paper. Attach to a 140mm square pink base card as shown.

**2** Cut two 65mm circles from patterned paper and a pennant tab from matching patterned paper. Attach to base as shown.

**3** Attach die-cuts from the mixed bag using sticky fixers and double-sided tape. To finish, add puffy stickers.



### Shopping list

My Mind's Eye Meow: 6x6 paper pad, £5.99; Mixed Bag, £5.99; Puffy Stickers, £4.99  
**From Hey Little Magpie**

My Favorite Things Fishtail Flags Stax Dies, £15.95  
**From My Mum's Craft Shop**

Die-cutting machine, nesting circle dies, pink card, grey card  
**From your local craft shop**

For stockists turn to page 91

Just lovely

## Beauty begins

**1** Layer a 128mm square of pink patterned paper onto a piece of Kraft card. Ink the edges and add taupe ribbon across centre. Attach to a 135mm square white base.

**2** Layer a 90mm square of coordinating pink paper onto a piece of Kraft card and ink edges. Add to base.

**3** Trim a lady from the pad and attach at an angle. Fold and assemble a mini pocket. Attach at angle, adding a topper.

**4** Place a tag in the pocket, ink edges and attach a circle chipboard flower to each corner. To finish, tie a piece of twine through a chipboard button and attach in the lower right corner.



### Shopping list

Graphic 45 Portrait of a Lady: 8x8 paper pad, £10.95; Decorative Chipboard, £5.45; Journalling Chipboard, £5.45; Tags and Pockets, £4.75  
**From Charmed Cards & Crafts**

Kraft card, Vintage Photo Distress Ink, taupe ribbon, twine  
**From your local craft shop**

For stockists turn to page 91

Design by Jo Nevill

Design by Lisa Plummer

Vintage appeal

## Elegance

**1** Layer a 125mm square of striped brown paper onto Kraft card and ink the edges. Attach to a 135mm square base card. Layer a 65x115mm piece of pink patterned paper onto Kraft card, ink the edges and attach to base.

**2** Layer a 90mm square of rose paper onto Kraft card and ink the edges. Cut a border strip and add to bottom. Attach to base.

**3** Assemble two pockets and ink the edges. Add a chipboard message and lady to the pink pocket and attach to base. Add a tag and chipboard lady to the large pocket. Attach using sticky fixers.

**4** Add a tag to bottom left. Cut a sentiment from the paper pad and stick onto the chipboard tag. Add gems, to finish.



### Shopping list

Graphic 45 Portrait of a Lady: 8x8 paper pad, £10.95; Decorative Chipboard, £5.45; Journalling Chipboard, £5.45; Tags and Pockets, £4.75  
**From Charmed Cards & Crafts**

Kraft card, Vintage Photo Distress Ink, gems  
**From your local craft shop**

For stockists turn to page 91

Design by Lisa Plummer

Pretty in pink

## Newborn

**1** Attach a 135mm square of pink paper to a 140mm square white base card. Attach two 120mm squares of contrasting patterned paper, overlapping at angles. Draw faux stitching around each of the three squares.

**2** Trim the nursery rhyme paper to create a 140x50mm pennant. Add a 20x25mm pink pennant to the bottom reverse and attach to base with sticky fixers.

**3** Add a 'newborn' sticker and outline with a black fineline pen. To finish, add ephemera pieces using double-sided tape and sticky fixers.



### Shopping list

Carta Bella Rock-a-Bye Baby Girl 12x12 Collection, £16.49  
**From Craftie-Charlie**

Black fineline pen  
**From your local craft shop**

For stockists turn to page 91

Design by Tracey Grundy

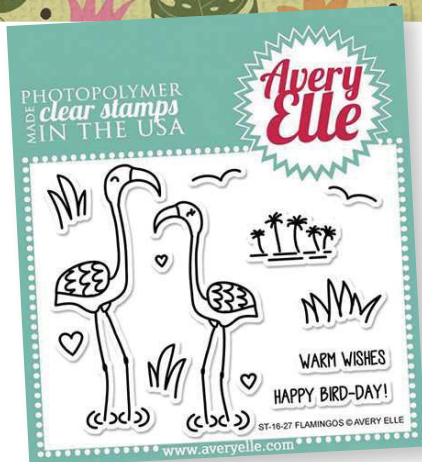

### Tropical treasures

Avery Elle Clear Stamps – Flamingos, £5.95  
[www.mymumscraftshop.co.uk](http://www.mymumscraftshop.co.uk)



Flamingo Bay Weekend Bag, £29.95; Flamingo Bay Washbag, £12.95; Flamingo Bay Make Up Bag, £6.95; Dotcomgiftshop

## Trend Spotter Flamingos

Start your summer crafting with a touch of pink – pink flamingos that is! These beautiful birds are sure to please, so stock up your stash today

### Bold and bright

Kaisercraft Flamingo Pink 12x12 Glitter Cardstock, £1.95  
[www.merlyimpressions.co.uk](http://www.merlyimpressions.co.uk)



### Just peachy

Stickles Glitter Glue – Neon Flamingo, £1.99  
[www.papermaze.co.uk](http://www.papermaze.co.uk)



### Pretty in pink

Lawn Fawn Plastic Flamingo Ink Pad, £5.95  
[www.sevenhillscrafts.co.uk](http://www.sevenhillscrafts.co.uk)

### Birds of a feather

My Mind's Eye Palm Beach Flamingos Paper, 95p each  
[www.hey littlemagpie.com](http://www.hey littlemagpie.com)



### Elegant embellishments

Daisy Trail Flamingo Fancy digikit, £3.99  
[www.shop.daisytrail.com](http://www.shop.daisytrail.com)



### Pretty pastels

Doodlebug Fun in the Sun Flock of Flamingos Decorative Washi Tape, £4.39  
[www.craftie-charlie.co.uk](http://www.craftie-charlie.co.uk)

### Fancy flamingos

Echo Park Flamingo Palm Die, £14.95  
[www.craftelier.co.uk](http://www.craftelier.co.uk)

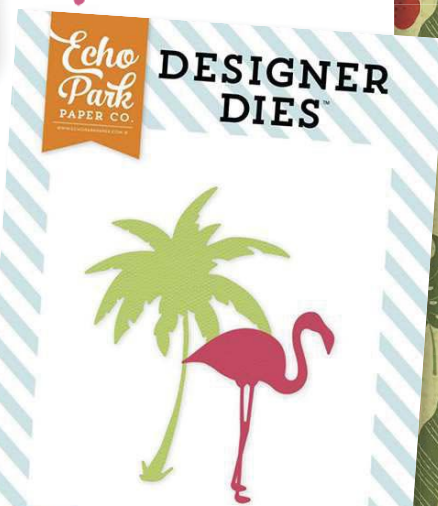

Flamingo Palm Die Set  
 CUTS THROUGH PAPER, CARDSTOCK & OTHER THIN MATERIALS  
 FOR MORE SHAPES AND IDEAS VISIT [ECHO.PAPER.COM](http://ECHO.PAPER.COM)  
[www.cardmakingandpapercraft.com](http://www.cardmakingandpapercraft.com) 41

★  
MASTERCLASS  
Pop-up  
cards



# Friendly felines

Make pop-up cards the easy way with Stampendous dies and **Carolyn Knott's** cat-tastic design inspiration

Turn the page for your step-by-step instructions



## Cardmaking & Papercraft MASTERCLASS



**Project:** Pop-up cards

**Time:** 1-1/2 hour per card

**Expert:** Carolayne Knott

Carolayne has been cardmaking for over 15 years and she is now an expert on everything from stamping to die-cutting. She loves testing new ideas and experimenting with new products. This issue she's created fabulous pop-up cards using the new pop-up dies and stamps from Stampendous. Turn the page to get started on your own!

## MASTERCLASS

### Pop-up cards

Create wow-factor pop-cards with beautiful butterflies and friendly felines using oh-so-easy Stampendous dies

Pop-up cards have been around for quite a while, but they have usually involved carefully working out and measuring to make sure the mechanisms work. All this has changed with the new Stages dies from Stampendous, and pop-ups are now easier than ever to make.

This set of dies cuts pop-up platforms and tiny tabs, and the dies can be used either independently or in combination with each other to create simple or more complex versions of pop-up cards.

For this set of three cards, I've used the stylised cat and butterfly stamp sets from Stampendous that have been developed to coordinate with the pop-up range. These work brilliantly either on their own or together. However, as the butterflies are smaller images, they sometimes allow the column and platform pop-up elements to show. They can still be used by simply adding a larger element behind them, such as the fence that I created from strips of card as something for them to be landing on. Enjoy playing with these dies – there is so much they can do!

### Shopping list

Stampendous: Stages Pop Up Die Set, £19.99; Stampendous Laurel Burch: Indigo Cats dies, £16.99; Indigo Cats stamp set, £10.99  
**From Crafts U Love**

Spellbinders Scalloped Borders  
 Two dies, £11.95  
**From IconUK**

Die-cutting machine, small bow die, patterned papers, Kraft card, orange pen, sentiment stamps, colouring pencils  
**From your local craft shop**

For stockists turn to page 91

## Simple



**1** Mark the middle of a 260x145mm piece of green patterned paper. Line up pop-up column dies 3 and 2 (turning 2 so the etched number is upside down) along the middle line, approximately 40mm in from left and right of the card, and die-cut.

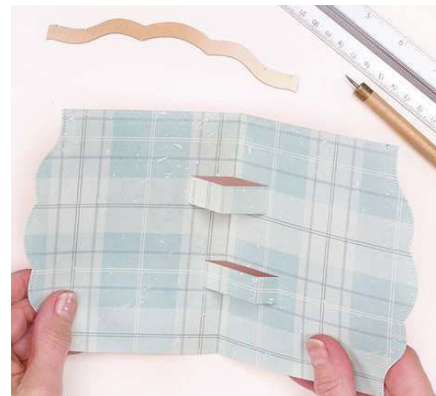

**2** Die-cut a scalloped edge from each end of the panel approximately 100mm from the centre line. Score the area along the centre line that has not been cut into tabs and gently work the folds to create the pop-up elements.

## Intermediate



**1** Attach a 145x120mm piece of cloud and a 145x130mm piece of green patterned paper, overlapping by 10mm. Cut a scalloped border at ends; add green, blue and orange patterned papers to make a 145x290mm base. Add a narrow cream border at the top and a strip at the bottom to cover the joins.



**2** Mark the middle of the panel and line the pop-up platform die (7) 35mm from the left edge and a tab 40mm from the top right of the panel. Add tab 2 (turning so the number is upside down) to the top of the platform, lining up the score lines, and run through your die-cutting machine.

## Advanced



**1** Attach a 145mm square of blue paper to a 145x155mm piece of green patterned paper, overlapping centrally by 10mm. Repeat to make a second panel. On one panel, align column dies 1, 3 and 2 (number upside down) as shown. Cut small tabs 35mm and 25mm from the top and 25mm from the bottom for butterflies and sentiment.



**2** On the second panel, cut column dies 6 and the platform die (7), as shown. Cut tabs 35mm and 25mm from the top of the panel and 25mm from the centre of the bottom of the panel. On both panels, score along the centre lines between the pop-up tabs and gently crease the folds to create the pop-up elements.

# Carolynne's hints & tips



Follow these handy hints from Carolynne to help you create your fabulous pop-up cards

★ Create a template using a piece of spare card to show what type of pop-up effect each die gives.

★ Don't be limited in how to use the dies. They can be turned upside down, for example, and dies 1, 2 and 6 can also be used on top of a platform die.

★ Working the folds from the back can be easier, but if you accidentally fold part of a column that should be straight, add a piece of card behind to strengthen. Once something is attached to the front, you won't see a fold line.

★ To get a more layered effect, make sure that stamped images are set at different levels and overlap.

★ When attaching your die-cut shapes to columns and platforms, try closing the base before attaching them in place, to make sure nothing sticks out of the edges when folded.



**3** Cut two 145x35mm pieces of orange paper. Attach behind the scalloped edges so the panel measures 290mm long. Add a narrow white scalloped border along the top green scalloped edge. Add panel inside a 145mm square white base card.



**4** Stamp, colour and die-cut two cats from Kraft card. Attach to the tabs. Add a stamped sentiment with faux stitching on orange card, a die-cut bow and white scalloped border to finish. Make panels for the front and back of the base.



**3** Score and fold along the centre to create the pop-up elements. Die-cut a scalloped border on a 140x75mm piece of striped paper and align the platform die centrally to remove the section so it fits around the pop-up elements; attach. Add the panel into a 145mm square base.



**4** Stamp, colour and die-cut six butterflies from Kraft card. Round the tops of 14 8x45mm and four 6x100mm strips of white card and attach to create two fences. Add the fences to the platform and attach a sentiment. Add butterflies. Decorate the front of the base.



**3** Cut two 145x75mm orange panels with scalloped edges to fit around the pop-up elements. Add a thin border from cream card. Score a 290x285mm piece of white card at 145mm along the longer edge and 140mm on the shorter edge. Use a craft knife to remove a 3mm slit from the centre down to the bottom edge and attach the pop-up panels.



**4** Stamp, colour and die-cut seven cats and six butterflies from Kraft card. Round the tops of 12 10x45mm strips of white card to create a six-piece fence and two three-piece fences. Attach behind columns on left panel and front of platform on right. Add cats, butterflies and a sentiment. Decorate reverse of all panels and the front of the folded card.

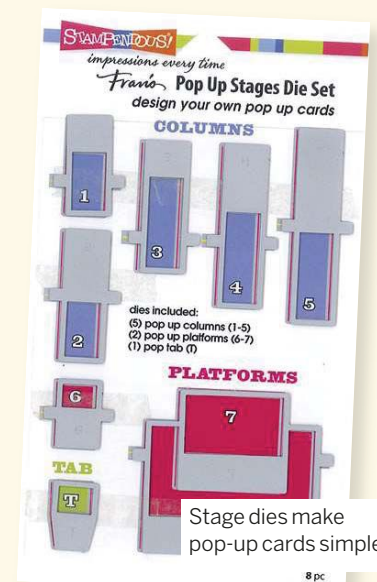

Home  
sweet home

### Shopping list

Sizzix Tassel Tastic Dies, £14.99  
From HOCHANDA

Die-cutting machine, black card,  
yellow card, yellow cord, brads,  
toothpicks, piercing tool  
From your local craft shop

For stockists turn to page 91



# To the graduate

Celebrate commencement day with a degree of fun using  
**Clare Buswell's** fantastic mortarboard-inspired designs

## Cupcake toppers

*Add an extra touch to your cakes with these adorable cap and diploma toppers!*

**1** Trace the template from page 88 onto black card and cut out. Trace the top square of mortarboard again and cut out. Layer top square onto mortarboard using sticky fixers. Attach wooden skewer to back of topper, and cover back with a piece of card.

**2** Cut an 80x100mm piece of white paper or card. Roll into scroll shape, secure with strip of black paper. Using template

on page 88, trace the ribbon onto black card and cut out. Attach to the reverse of the scroll and add a wooden skewer to back of topper. Cover back with white card.

**3** Repeat to make several mortarboard and scroll toppers, and insert into cakes, to finish.



## Mortarboard gift box

*Give the graduate a little something special in this adorable cap and tassel gift box*

**1** Trace the box base template from page 87 onto black card and cut out. Score along lines and fold. Assemble the box. Trace the box top template, onto black card and cut out. Score along lines, fold and assemble.

**2** Measure a 120mm square on black card, add 10mm tabs on all sides and cut out. Score along lines and fold. Stick tabs down using double-sided tape. Attach square to top section of

box. Measure to find the centre and pierce a hole.

**3** Die-cut a tassel from yellow card or paper and assemble. Attach tassel to piece of yellow cord, thread through the hole and secure inside of box. Attach a brad to cover hole at top of box, to finish.



## Mortarboard card

*Celebrate your graduate's momentous achievement with a mortarboard card*

**1** Trace the card template from page 88 onto black card, cut and score. Fold along the scored lines to assemble.

**2** On the front of the card, find centre point of mortarboard, pierce hole and add cord or twine. Make a mini tassel from lengths of twine and attach. Add a brad to cover hole.

**3** Cut a 95mm square of yellow card and attach onto

the pointed side of the card. Cut a 140mm square of yellow card, trim the top into a triangle and attach to the bottom half of the base. Print text onto card or paper, trim, and layer onto the yellow card as shown. Using the template on page 88, trace small mortarboard onto black card, cut out and attach using sticky fixers, to finish.



# 3 ideas for... your bonus papers

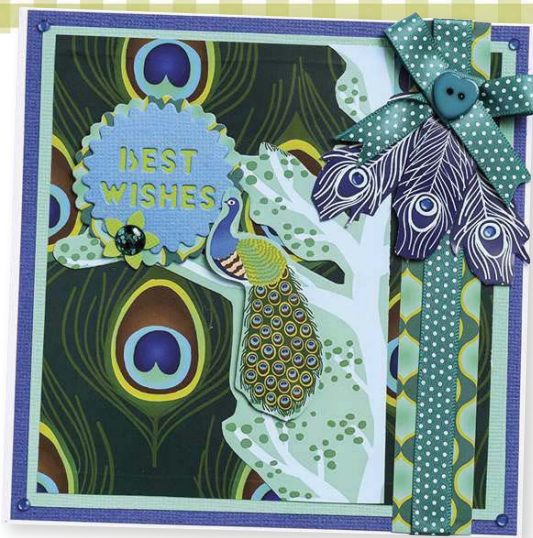

## 1 Best wishes

**1** Layer a 120mm square of peacock feather paper onto teal then blue card. Attach a 20mm wide strip of patterned paper to the right-hand side of the panel, and wrap with ribbon. Attach to the front of a 135mm square white base. **2** Fussy cut a tree and attach to base as shown. Die-cut a sentiment from blue card and back with lime green card. Layer onto a larger scalloped circle die-cut from patterned paper, and add to base with sticky fixers. Add a punched flower and dome sticker to the sentiment. **3** Fussy cut a peacock; attach. Add a ribbon bow and heart button in the top right corner. Fussy cut three feathers, and attach under the bow. Finish with gems.

Download  
**PAPERS**  
for free  
from [www.cardmakingandpapercraft.com](http://www.cardmakingandpapercraft.com)

Sarah Jackman Read has three beautiful card ideas to make with Matilda Smith's elegant peacock papers

## 2 With love

**1** Layer a 120mm square of patterned paper onto blue, then lime green card, then add to a 135mm square white base. Add a 132x28mm strip of peacock paper. **2** Die-cut a scalloped circle frame from blue card. Glue a die-cut circular peacock image behind the frame, then attach to the base. Fussy cut three large peacock feathers and attach next to the frame. **3** Die-cut a sentiment from lime green card, layer onto blue card, then attach with sticky fixers. Add a punched flower and dome sticker to the top. Attach a ribbon bow and heart button to the frame, and finish with gems.

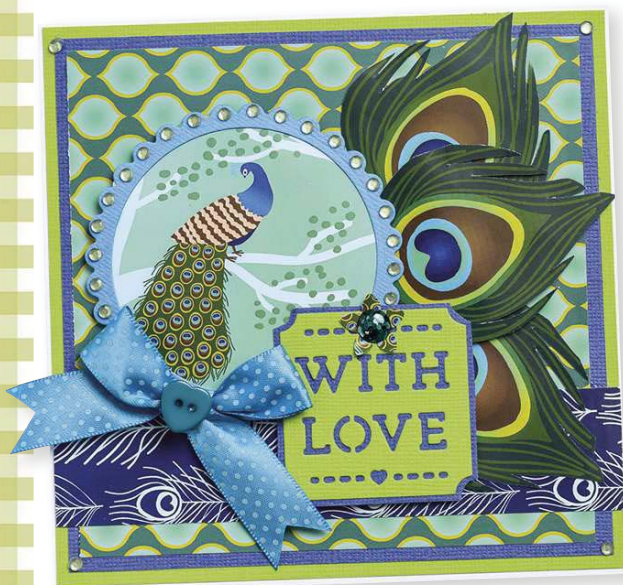

## 3 Get well soon

**1** Layer a 115mm square of peacock feather paper onto lime green then blue card. Attach a 132x30mm strip of patterned paper in the centre, wrap with ribbon, then attach to a 135mm square white base card. **2** Die-cut a sentiment from blue card, layer onto green card, then attach to the base with sticky fixers. Die-cut a scalloped circle from patterned paper, cut in half and attach above and behind the sentiment. Fussy cut two peacocks and attach to the top of the sentiment, using sticky fixers. **3** Punch three flowers from blue card, and glue towards the bottom. Add dome stickers in the centres. Add a heart button to the top of the sentiment, and finish with gems.



More  
**DESIGNER  
PAPERS**  
to download for free  
from [www.cardmakingandpapercraft.com](http://www.cardmakingandpapercraft.com)



Click on 'cardmaking'  
then 'cardmaking papers'  
on our homepage

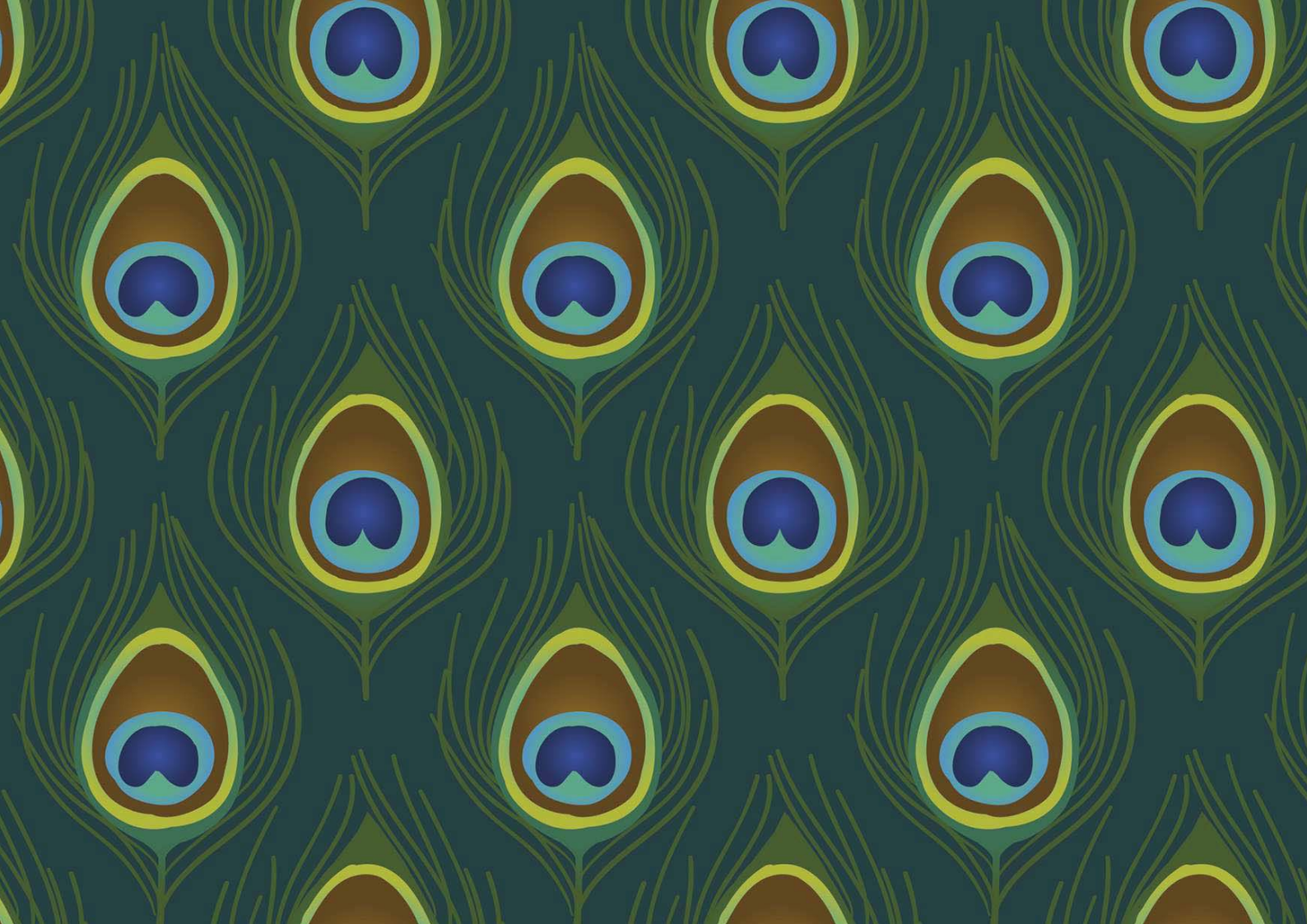

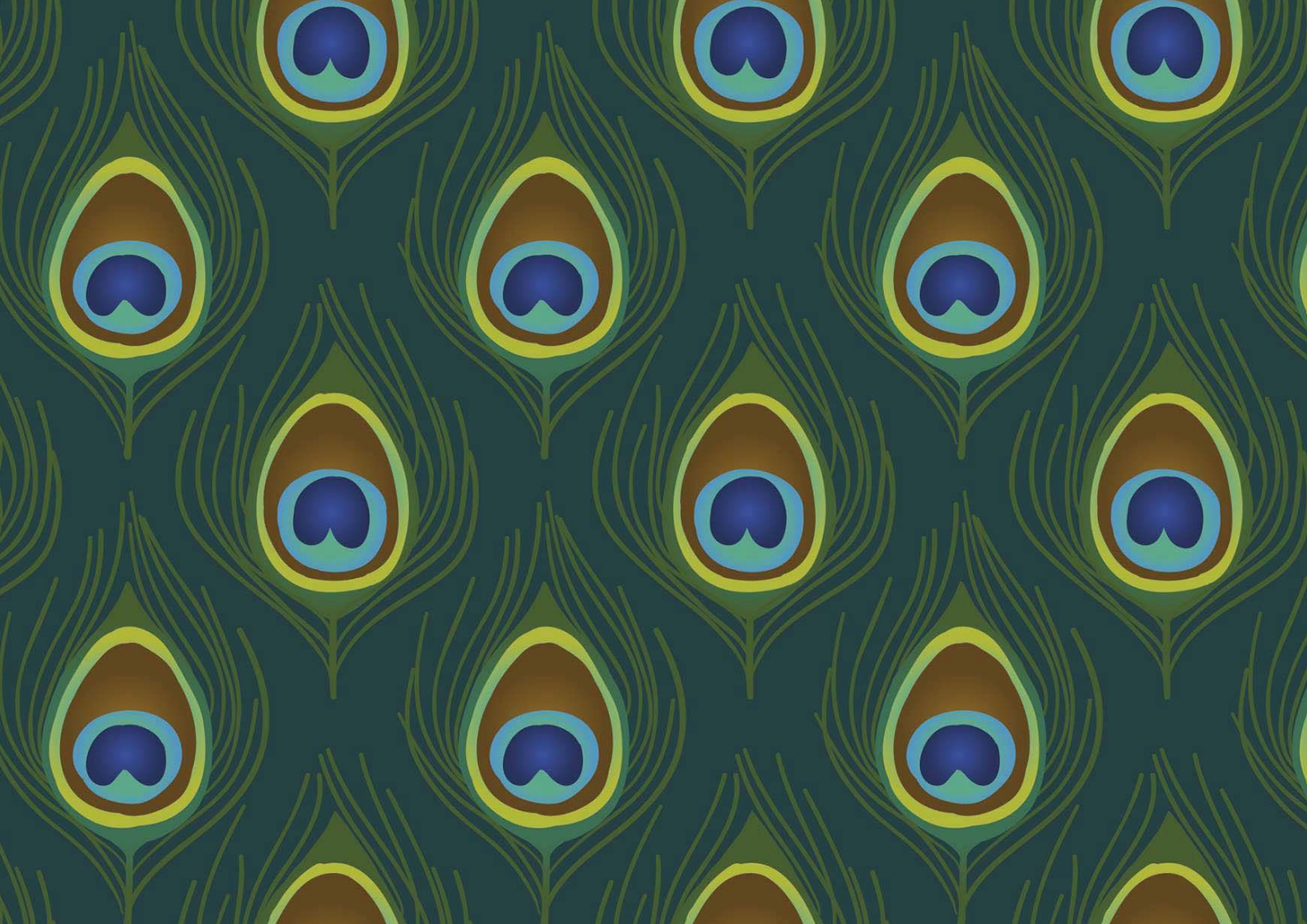

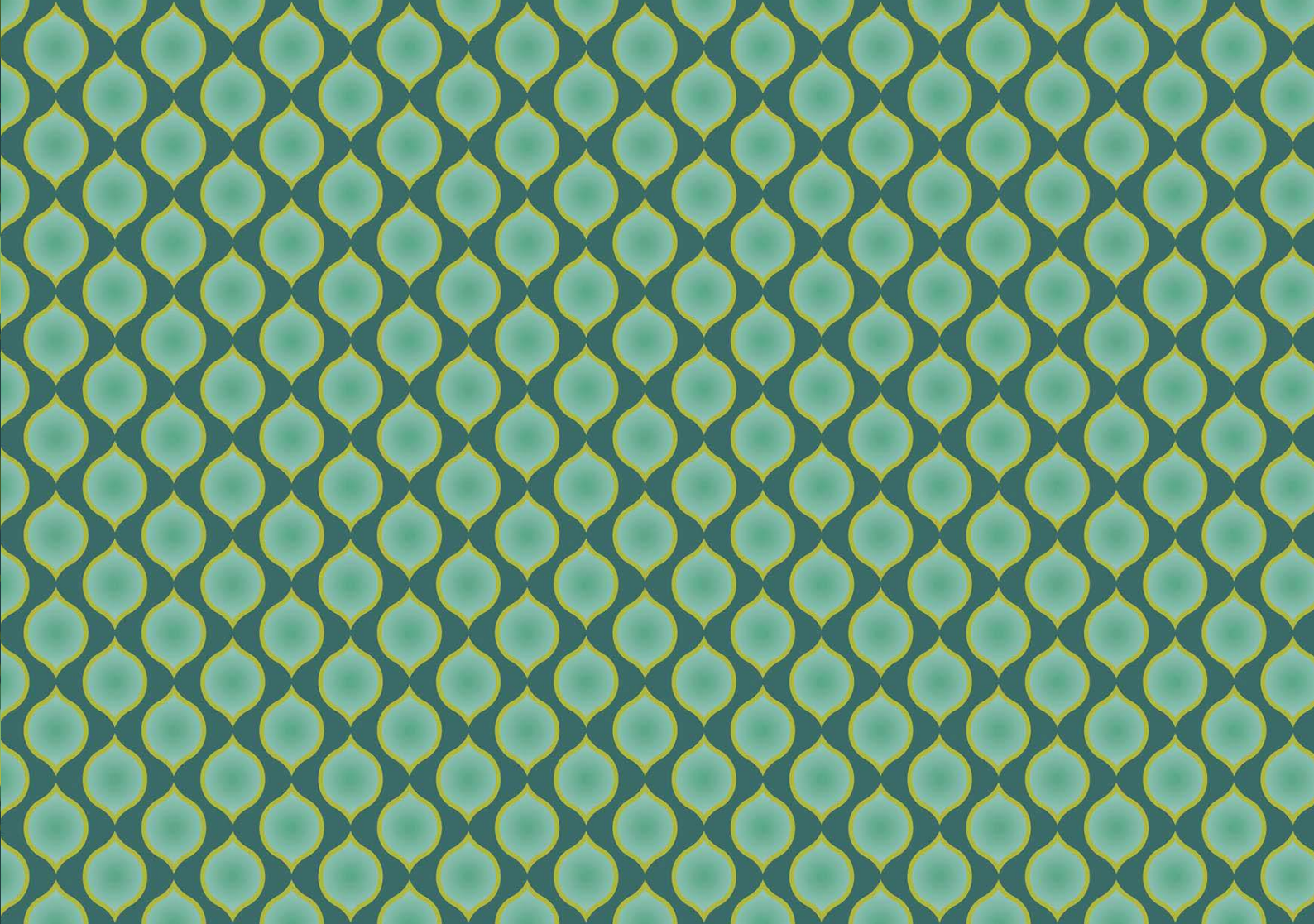

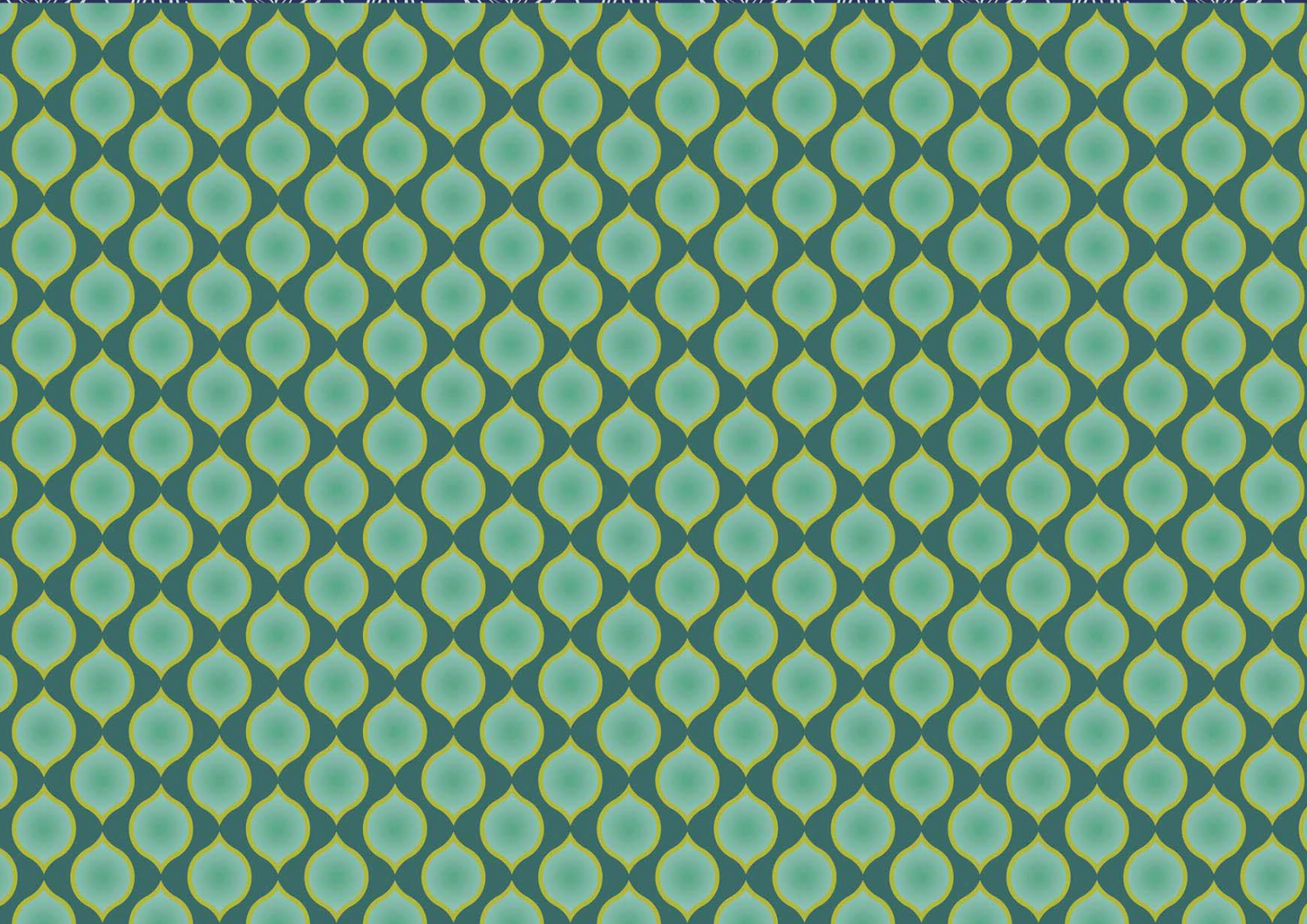



## Manchester crafts

The organisers of the Stitching, Sewing & Hobbycrafts show are offering 10 readers the chance to win a pair of tickets to the event. Taking place at EventCity from 7th-9th September, the show will feature over 100 exhibitors. This is the perfect occasion for craft lovers to stock up on supplies, get tips from the experts, take part in hands-on demonstrations and plenty of workshops, too. For more info visit [www.ichfevents.co.uk](http://www.ichfevents.co.uk).

**To enter text ICHF171, your name, address and email to 87474\*.**

**Texts will be charged at 50p plus your standard network tariff rate.**



## Character building

Introducing the whimsical world of Kori Kumi, Santoro's newest collection. This award-winning papercraft collection is brought to you by Craft Consortium and will transport you to a blissful world of friendship and adventure. Each winner will receive 10 fabulous premium character stamps, including Melon Shower, Blowing Kisses, Dreamboat and more! To view the whole Kori Kumi range, visit [www.craftconsortium.com](http://www.craftconsortium.com).

**To enter text SANTORO171, your name, address and email to 87474\*.**

**Texts will be charged at 50p plus your standard network tariff rate.**

# Prize time!

Enter our special prize draws for your chance to win some lovely crafty prizes.



## Decopatch designs

We've teamed up with ExaClair to offer 12 lucky readers a chance to win their very own Decopatch kit, with everything included to get started on an exciting craft project. There are six travel-themed and six love-themed kits up for grabs. The travel-themed kit comes complete with a maché camel and selection of tropical, holiday-inspired papers. The love-themed kit boasts cute, kitsch and romantic papers with a ready-to-decorate maché trinket box, photo frame and ornament. Each winner will also receive glue and a brush so that they can get crafting immediately. For more information please visit [www.decopatch.com/index-en.html](http://www.decopatch.com/index-en.html)

**To enter text DECOPATCH171, your name, address and email to 87474\*.**

**Texts will be charged at 50p plus your standard network tariff rate.**



## Easy crafting

Easycraftideas has set out to help those new to crafting with their fabulously simplistic style. The Easycraftideas products are easy to colour, cut and transform into fantastic cards and projects! We're thrilled to offer 10 readers the chance to win a fab prize bundle, featuring an A6 Romantic Roses stamp set and Lovely Lilies stamp set, too. Plus, each winner will also receive a beautiful colouring pad, which includes 11 design sheets (3 of each) consisting of a range of toppers, messages, borders and backgrounds. To view the whole range, visit [www.easycraftideas.co.uk](http://www.easycraftideas.co.uk).

**To enter text EASY171, your name, address and email to 87474\*.**

**Texts will be charged at 50p plus your standard network tariff rate.**

### Terms & conditions of entry

**The closing date for entries is 11.59pm on 20/07/17.**

**Enter online at [www.cardmakingandpapercraft.com](http://www.cardmakingandpapercraft.com)**

**To enter by post:** write your name, address and the keyword from your chosen prize on the back of a postcard (one entry per postcard please) and send to: Cardmaking & Papercraft 171, 2nd Floor, Tower House, Fairfax Street, Bristol BS1 3BN.

**Promoter:** Immediate Media Co Bristol Ltd. Promotion excludes Immediate Media employees. Open to UK and Channel Islands entrants only. By entering, you agree to be bound by all the rules of the promotion. Only one entry per person per prize draw. No responsibility accepted for lost, delayed, illegible or fraudulent entries. Direct queries to [writetous@cardmakingandpapercraft.com](mailto:writetous@cardmakingandpapercraft.com)

com or call 0117 927 9009. Winning entries will be chosen at random from all eligible entries. Winners will be notified within 28 days of closing date. The draw is final and no correspondence will be entered into. For details of winners send an SAE within two months of the closing date. If any winner is unable to be contacted within one month of the closing date, the Promoter will offer the

prize to a runner-up. Promoter reserves right to substitute prize with one of same or greater value. There is no cash alternative.

\*By entering this competition you are agreeing to receive details of future offers and promotions from the Immediate Media Group and related third parties. If you do not want to receive these write 'NO INFO' at the end of your text message or on your postcard.

# Parchment craft precision

*Maria Simms has put together a parchment craft tutorial that's perfect for beginners! Etch, colour and present this beautiful parchment piece with just 11 easy steps*



Learn parchment craft with Maria

The Groovi Parchment System from Claritystamp is a versatile modular system that was born out of a yearning to create beautiful pieces of parchment art without the need for lots of time, knowledge, patience or even confidence!

The system, which is suitable for crafters both young and old, is a series of precision-etched acrylic plates designed to transfer beautiful line art onto parchment paper quickly, easily and accurately, using a minimum of tools.

Once the white line art is completed, it is up to you to decide how far to take the design. The artwork will already look beautiful as it is, though you may like to add colour with pencils or pens. You could also decide to explore some of the beautiful traditional parchment techniques that complement Groovi artwork so well.

This step-by-step Groovi project is the first in a three-part series. This month, we will start at the beginning and get to grips with the basics. Then next time we can introduce a couple more techniques, building in skills and confidence to continue on to more advanced projects in future months.



## Shopping list

Groovi Plate Starter Kit Deluxe, £49.99; Nested Ovals Groovi Plate, £7.99; Nested Scallops Square Groovi Plate, £7.99; Sprig Background Groovi Plate, £7.99; Garden Bird – Small with Branch A6 Square Groovi Baby Plate, £4.99

**From Claritystamp**

Coloured pencils, A5 translucent parchment paper, mirri card, removable tape, Perga Glue

**From your local craft shop**

**For stockists turn to page 91**

## Maria's top hints & tips

- ★ Start with freshly washed hands, as any natural oils on your hands can transfer onto and mark your parchment.
- ★ Use a piece of kitchen towel to rest your hand on while you craft. This will help protect your parchment.
- ★ Rubbing your parchment with a tumble dryer sheet before etching it will help the tool glide easily on your project.
- ★ Pressing firmly with your tool will help you stay in the grooves of the design.
- ★ When colouring your parchment, build up colour slowly using light strokes, as this will give a softer, more blended look.

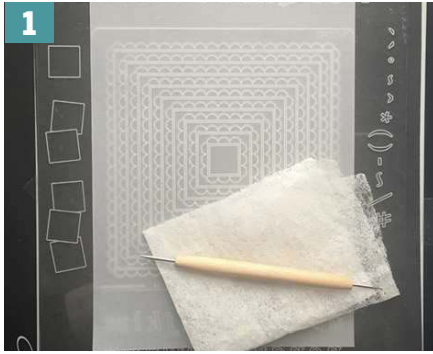

**1** Slot the scallop square plate into the Plate Mate. Use removable tape to attach a piece of parchment, and rub with the tumble dryer sheet from the starter kit.

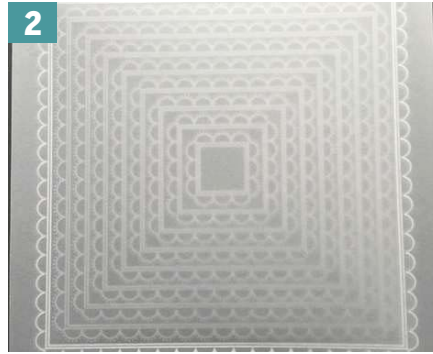

**2** Using stylus number 1, the smallest tool that comes with the Groovi starter kit, etch the largest scallop square into place on your parchment.

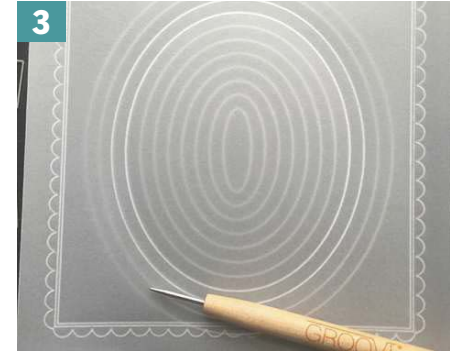

**3** With the parchment still in position, replace the square plate with the nested oval plate and etch the third and fourth largest ovals.



**4** Replace the oval Groovi plate with the sprig plate. Now etch the sprig design in the blank area between the outer oval and the scalloped square frame.



**5** Remove the sprig plate and replace with the inset/adaptor plate for the Garden Bird baby plate. Reposition the parchment and etch the branch.



**6** Reposition the parchment again and etch the Garden Bird so that it is sitting on the branch, as shown.



**7** Etch a sun/moon shape above the bird as shown, using the landscape plate that comes with the starter kit. Then remove the parchment from the Plate Mate.



**8** Lay the parchment on the solid side of the black mat from the starter kit. Continuing to work on the same side of the parchment, start to colour the design with pencils.



**9** Once you have coloured your bird, branch and sun, colour the oval frame using pink and brown pencils. Gently overlap the colours for a blended look.



**10** Colour the leaves in the sprig design green, and fill in the inner edge of the scalloped square border with brown coloured pencil. Now, flip your parchment over.



**11** Layer your parchment onto coloured paper, using a tiny amount of Perga glue in the four corners. Add embellishments to cover the glue. Layer onto mirri card and a 7x7 base.

## Meet Maria

Papercraft demonstrator and tutor Maria Simms has been doing parchment craft for several years and was part of the team that launched the Groovi Parchment System for Claritystamp. Check out her blog for more cardmaking projects, as well as recipes! <http://inkymits.blogspot.co.uk>



My favourite things

# Leonie loves Stamped patterns

Get creative with Leonie Pujol's versatile stamp sets to **build fun and fabulous patterns** for your cards



**H**i again crafters. Wonderful to have your company. As I write this I am actually in the process of moving house, so crafting in between the packing has been interesting. I seemed to find that I was spending more time looking for things rather than crafting... even more than I normally do! It'll get there, but I feel it may be some time before I find everything again.

I did manage to make some projects, of course.

This month I wanted to work with my stamps again, but not using them with the masks they were designed to

*"I feel it's important to show different ways of working with products..."*

work with. I feel it's important to show different ways of working with products in order to demonstrate the diversity and the different results which can be obtained.

These stamp sets are so great for versatility, as there are over a dozen different stamps in each, and they're all small enough to work together to create funky patterns and backgrounds that will really enhance your work. You'll find lots of different combinations, and a huge range of patterns which you can achieve – it is really addictive!

*Leonie*

See Leonie Pujol presenting every week on HOCHANDA, visit her blog at [www.leoniepujol.blogspot.com](http://www.leoniepujol.blogspot.com), and find her videos at [www.youtube.com/Leoniepujol](http://www.youtube.com/Leoniepujol)



## Little mouse

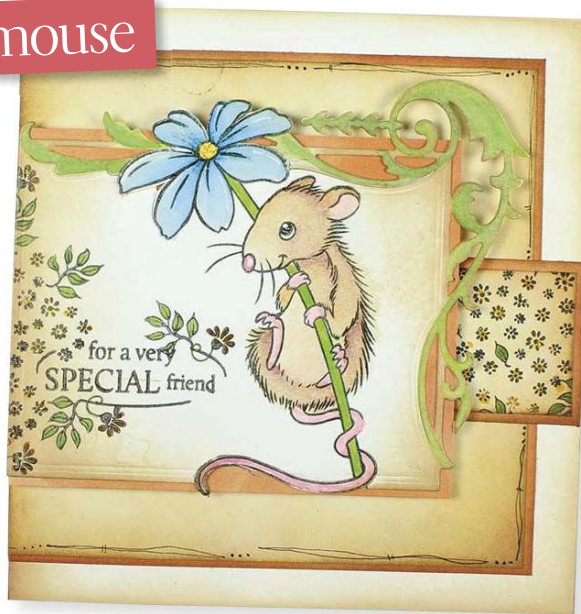

**1** Stamp your lovely little mouse on a piece of cream card. Place the Elegant Frames die over the image and calculate the part of the image that will go outside the cutting edge of the die. I planned to have the flower head and mouse's tail outside of the die, so I marked where they would extend past the cut line.

**2** Using a craft knife, cut out the flower where it will extend over the die-cut. You'll have to cut into the image a little further to be able to lift the flower over the die.

**3** Place the die on the card, ready to cut out the image, but bring the part of the flower you have pre-cut, over the top of the die. This will allow you to cut out the stamped image, but have the flower extending outside the cut line.

**4** Stamp a sentiment from the Milton stamp set, and use the Branching Out stamps to create your own pattern. I used the smaller of the stamps, so they look like a continuation of the lines from the sentiment stamp.

**5** Stamp your pattern again onto a scrap of cream card and colour. Colour the mouse and the vine on the die-cut.

**6** I layered my scrap piece of card with my doodle pattern onto orange card and it became a really nice decorative border. I attached it to a 120mm square of brown card, orange card and 130mm square base, then layered the coloured panel on top with sticky fixers. Ink all the edges for a great result.

## Shopping list

Leonie Pujol clear stamps:  
Branching Out, £4.99  
**From Crafter's Companion**

Wild Rose Studios: Mouse & Flower stamp, £12.80; A5 Milton stamp set, £17.72; Elegant frames die, £36.70  
**From Amazon**

Die-cutting machine, Frayed Burlap Distress Ink, black fineline pen, Spectrum Noir Watercolour pens, craft knife; cream, orange and brown card  
**From your local craft shop**

**For stockists turn to page 91**

## Enjoy today

**1** First, pop the top of a 120mm square base card in your embossing folder, so only half will be embossed. I kept the card folded, so the front, inside and back are embossed, too!

**2** Next is pattern building. My stamp range has so many options for you, so just choose your favourite image. I find it's best to group the images together, as this way the pattern forms more coherently. Practise first on scrap paper. I also recommend using a small acrylic block,



as this will give you more control.

**3** Use one of the stamps to create a border between the pattern and the embossed line.

**4** Stamp your sentiment on a scrap piece of card. Colour another scrap of card using one of the pens you are going to use for your pattern. This will ensure you have colours in coordinating tones. Layer your sentiment onto the coloured card, and attach it above the stamped border.

**5** Now, colour in your pattern and add a little glitter glue, to finish.

## Leonie's hints & tips

Follow Leonie's expert advice and ideas for making cards with her clear stamp sets



★ I find when using these doodle design stamps, it is best to take the stamp to the ink pad, as this will be quicker for you, and easier to control them as they're smaller stamps.

★ If you make a mistake when stamping, there are lots of small stamps which come in handy for over-stamping splodges! Failing this, either pop a little glitter glue on, or use your drawing pen to turn your splodge into a dot, but remember to do more dots so it looks like it's part of the pattern.

★ Dry brushing is easier with a large (approx 1") flat paintbrush. Try to use nice long sweeps, and keep the paintbrush loose in your hand. You are not trying to paint the gesso on, simply 'sweep' it on across the image. You will find this will give you a lighter coverage.

★ If you get a little carried away with the gesso, you can always go back over the top with your acrylic paint – but try to avoid it being too thick as you will lose the definition of the pattern.

★ Pattern building is fun. Experiment, but keep a note of the stamps you use and the way they work together, and then you can go back to this time and time again. Also incorporate stamps you already own outside of the stamp set to change the look of the image.

### Shopping list

Leonie Pujol: Branching Out and Arrow to the Art stamps, £4.99 each; It's Snowing Embossing Folder, £4.99  
**From Crafter's Companion**

Die-cutting machine, sentiment stamp, Spectrum Noir Watercolour pens, Stickles Glitter Glue  
**From your local craft shop**

For stockists turn to page 91

## Joy

**1** Emboss scraps of card using the Typography embossing folders. I used a word and patterns.

**2** Create a mosaic by gluing the embossed panels to your canvas. Cut them down to mix the pattern up, vertically and horizontally.

**3** Paint the canvas. I went for a soft pastel tone for this. Allow paint to dry, then very gently dry brush white gesso over the top. This enhances



the embossing and gives you a shabby chic look.

**4** Gently sponge over the small 'Joy' mask with paint. Don't apply too much paint, to avoid working the paint under the mask. Cut into a pennant and layer onto a piece of black card.

**5** Die-cut the heart from white and black card. Create your stamped pattern on the white centre, allowing the stamps to fall off the heart.

**6** Glue the stamped heart to your canvas and add the black swirl in place. Don't completely stick this down initially, as you then want to put 3D glue onto your Joy banner. I wove it into the heart swirl, gluing part of the swirl to the canvas, and part to the banner.

**7** Add the die-cut word 'Love', using a mix of fonts, and add Glossy Accents. Attach gems, and draw a doodled border around the edges.

### Shopping list

Leonie Pujol: Branching Out and Arrow to the Art stamps, £4.99 each; Hearts and Swirls Overlay die, £19.99; Glitter Brush Pens – Bright Lights, £12.99; Mask and Stencils – Joy, £5.99; Typography Collection Embossing Folders: Dream Big, Patterns Rule, Swirls & More, £3.99 each; Typography Collection Dies: L, O, V, E, £2.49 each  
**From Crafter's Companion**

Die-cutting machine, white gesso, acrylic paint, black card, Cosmic Shimmer adhesive, black fineline pen, Glossy Accents, 140mm square canvas, black gems  
**From your local craft shop**

For stockists turn to page 91

# 10 ideas for... bird lovers

Set your eyes to the skies with Sarah Jackman Read's beautiful bird-themed makes



## 1 Mini frame

**1** Cover the front of a mini frame with green patterned paper. Emboss a piece of pearlescent paper from the pad and attach to the back of the aperture. Make a small stand with Kraft card and glue to the back. **2** Die-cut a bird and birdhouse from coloured card and attach as shown. Fussy cut a bird from the papers and attach in the bottom left corner. **3** Die-cut flowers and a heart in patterned paper; attach. Finish with pearls.



## 2 Birthday wishes

**1** Layer a 115mm square of flower paper onto pink card and attach to a 125mm square cream base. Emboss a 90mm square of pearlescent paper and layer on floral paper. Attach to base. **2** Glue baker's twine in a circle three times across the embossed paper. Add a bow towards the top of the circle. Attach a sentiment in the bottom right corner. **3** Die-cut a bird from pink card and branches from floral paper. Attach to the circle. Die-cut a heart and attach with sticky fixers. Add gems, to finish.

## 3 With love

**1** Layer a 90x135mm piece of green patterned paper onto cream card and a 110x145mm piece of striped paper. Wrap ribbon around the bottom and attach to a 105x150mm cream base. **2** Add a sentiment onto the ribbon. Die-cut a scalloped heart from flower paper and attach with sticky fixers. Die-cut branches from cream card and add across the bottom of the heart. **3** Die-cut birds, flowers and a birdhouse from coloured card and attach. Finish with gems.

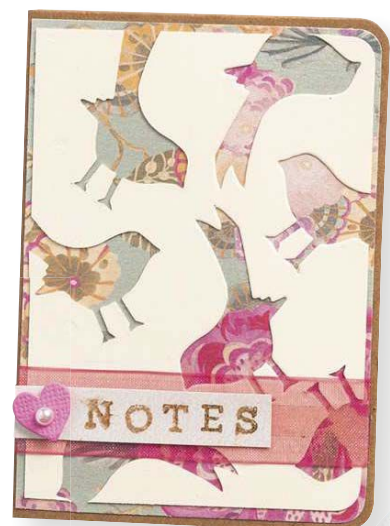

## 4 Gift bag

**1** Emboss a 90x135mm piece of cream card, and ink the raised pattern. Layer onto pink floral paper and a 110x170mm piece of green patterned paper. **2** Wrap purple ribbon around the bottom, and attach to the front of bag. Add a sentiment and a large bow to the ribbon. Fussy cut a bird and attach above the ribbon. Fussy cut the wing of a second bird and add over the top with sticky fixers. **3** Die-cut two birds and a heart and attach as shown. Add gems, to finish.



## 5 Mini journal

**1** Cut cream card and pearlescent floral paper slightly smaller than the front of the journal and round the right-hand corners with a corner rounder punch. Die-cut birds from the cream card. **2** Layer the cream card onto the floral paper and wrap pink sheer ribbon across the bottom. Attach to the front of the journal. **3** Stamp 'notes' on a strip of pearlescent paper and attach to the ribbon. Add a die-cut heart and pearl, to finish.



## 6 Garland

**1** Die-cut bird cages from pearlescent paper and attach to floral paper. Trim and glue evenly across a length of baker's twine. **2** Die-cut small flowers, glue to the top of the cages and add pearls to the centres. **3** Die-cut birds from various coloured card and attach to cages with sticky fixers.



## 7 Gift topper

**1** Cover your gift with striped paper, and wrap with ribbon. Die-cut two birds from red card. **2** Cut the wing off one bird and add on top of the other with sticky fixers. Attach to the top of the gift. Trim the sentiment into a pennant, tuck one end under the bird's wing and attach with sticky fixers. **3** Die-cut a heart from purple card and attach with sticky fixers. Finish with gems.

## 8 Bookmark

**1** Round the corners of a 45x145mm piece of cream card using a corner rounder punch, and emboss. Lightly ink the debossed side with purple ink. **2** Layer onto floral paper and round off the corners with a corner rounder punch. Stamp 'read' on a strip of pink card, trim to a pennant, and attach as shown. **3** Die-cut a bird and flowers from coloured card and branches from floral paper. Attach across the bookmark as shown.

## 8 Bookmark

## 8 Bookmark

## 8 Bookmark



## 9 Bird seed tag

**1** Create an 85x120mm tag from Kraft card, punch a hole in the top and round the corners with a corner rounder punch. Layer a 70x85mm piece of flower paper onto striped paper. Attach to tag. **2** Emboss an 85x25mm strip of cream card, and attach across the tag. Stamp 'bird seed' in brown ink onto a strip of pink card; attach. Die-cut a bird, branches, birdhouse and flowers in coloured card. **3** Attach the flowers in the bottom right corner and the rest of the die-cuts above the embossed strip. Thread baker's twine through the top of the tag. To finish, add a twine bow and pearls.

## 10 Birdhouse box

**1** Using the templates on page 86 to create the box from pearlescent paper. Repeat with the roof using Kraft card, then decorate the panels with patterned paper. **2** Die-cut birds, branches and flowers from coloured card and attach around the aperture. Glue acetate behind the aperture. Add double-sided tape to the box flaps and secure the roof in place. **3** Die-cut a tag from cream card, emboss and add a sentiment. Thread with baker's twine and attach to the roof. Add a satin ribbon bow on top of the twine, and finish with pearls.



## Shopping list

Dovecraft Painted Blooms: 12x12 Premium Paper Pad, £12.50; Embossing Folder, £3.40; Sentiment Toppers, £1.90

**From Buttercup Crafts**

Sizzix Sweet Bird Thinlits Dies, £10

**From Hobbycraft**

Die-cutting machine, scalloped heart die, heart and circle nesting dies, flower dies, tag die, corner rounder punch, pearls, gems, coloured card, Kraft card, baker's twine, cream satin ribbon, purple satin ribbon, pink sheer ribbon, alphabet stamps, purple ink, brown ink, acetate, Kraft gift bag, mini journal, mini wooden frame

**From your local craft shop**

**For stockists turn to page 91**

**fold away** Petite

*new*

# Salcombe Edition



**Petite Salcombe & Hutch**  
Regular Price £1120  
(excluding delivery and lighting kit)

**Petite Salcombe**  
Regular Price £795  
(excluding delivery)

**Magazine Offer**  
**£650 (SAVE £145)**

Mainland UK delivery £30 extra  
**Offer Coupon - SAL715**

- § Choose unit with or without hutch storage top section
- § Optional built in lighting pack in the hutch
- § On wheels for ease of movement
- § Adaptable shelves for threads, ribbons or storage boxes

**Magazine Offer**  
**£895 (SAVE £225)**

Mainland UK delivery £35 extra  
Optional lighting kit £50 extra  
**Offer Coupon - SALH715**

**Already have a Petite?**  
**Buy a hutch for just**  
**£325**



Unit pictured in Oak finish



*best seller*

**fold away** Deluxe

# Arlington Edition



**Really Useful Storage Cabinet 190cm (KITD14)**  
Regular Price £659.10  
(excluding delivery)

**Magazine Offer**  
**£570 (SAVE £89.10)**

Mainland UK delivery £30 extra  
**Offer Coupon - D14SAVE**



Unit pictured in Vanilla finish



**Fold Away Deluxe - Arlington**  
Regular Price £1495  
(excluding delivery and lighting kit)

**Magazine Offer**  
**£1195 (SAVE £300)**

Mainland UK delivery £50 extra  
Optional lighting kit £50 extra  
**Offer Coupon - ARL715**

Offers expire end of month following magazine publication (eg. Jan Issue expires end of Feb)

Please note all furniture items are supplied self assembly - assembly can be arranged please call for further details and charges

[www.storage4crafts.co.uk](http://www.storage4crafts.co.uk)  
[mail@storage4crafts.co.uk](mailto:mail@storage4crafts.co.uk)

**Call us free**  
**0800 048 8606**

# 1 sketch, 3 ways

Anne Richardson creates three beautiful cards with travel stamps and just one sketch

This month Anne Richardson has created exciting, European travel-themed card designs using Stampin' Up!'s Chase Your Dreams stamp set and lovely patterned papers. Use her sketch and design inspiration to create your own cards.



## 2 Bonjour

Rotate the sketch 180 degrees. Layer a 110mm square of blue card onto black card and attach to a 120mm square base card. Layer a 120x65mm piece of patterned paper onto a 120x70mm piece of black card and attach to base. Stamp, colour and cut out the Arc de Triomphe image. Attach to a 75mm square of patterned paper and layer onto a white card. Stamp the sentiment, trim and add to base with a 70x10mm strip of patterned paper, as shown. Die-cut three flowers from patterned paper and add to the bottom with small pearls, to finish.

### What's a sketch?

If you haven't heard of this before, a sketch is a term used to describe a basic card layout. It's there to provide you with an idea of how to build up your card. From this you can introduce your own ideas by following the layout, but using your own choice of papers and embellishments.

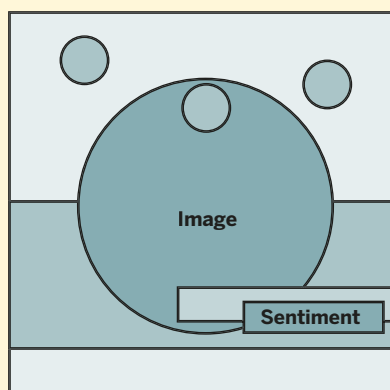

## 1 Hello

Follow the sketch exactly. Layer a 110mm square of black card onto orange card and attach to a 120mm square base card. Layer a 120x65mm piece of patterned paper onto a 120x70mm piece of orange card and attach to base. Stamp, colour and cut out the Tower Bridge image. Attach to a 75mm circle of patterned paper and layer onto a white circle. Die-cut three clouds from white card and add as shown. Attach circle panel to base. Stamp sentiment, trim and add to base with a 70x10mm strip of patterned paper, as shown.



## 3 Guten tag

Rotate the sketch 90 degrees. Layer a 110mm square of orange card onto blue card and attach to a 120mm square base card. Layer a 65x120mm piece of orange card onto a 70x120mm piece of blue card and attach to base. Stamp, colour and cut out the Neuschwanstein Castle image. Attach to a 75mm circle of patterned paper and layer onto a white circle. Stamp the sentiment, trim and add to base with a 10x70mm strip of patterned paper, as shown. Add three sequins in complementary colours, to finish.



## Create summer florals with... Barbara Gray

Summer is here and what better way to show it than with a **stunning floral frame** using Jayne Nestorenko's stamp sets

**D**on't you love the warmth of summer? When the sun is shining and there is a gentle breeze, there's nothing quite like sitting in the garden, listening to the birds and enjoying the flowers.

Here is a beautiful floral stamp set designed by our dear friend Jayne Nestorenko, who is sadly no longer with us, but who left us a wonderful legacy of floral tributes. I have tried to emulate her way of colouring in this project. She was a very gentle woman, softly spoken and never loud. I think the pastel pinks and greens I have used reflect her and her style well. I often think about Jayne. She is missed by many of us. But how grateful am I that she had the vision to pass on her art to us, for all to enjoy, before she went on ahead.

Barbara  
Claritystamp  
LIMITED

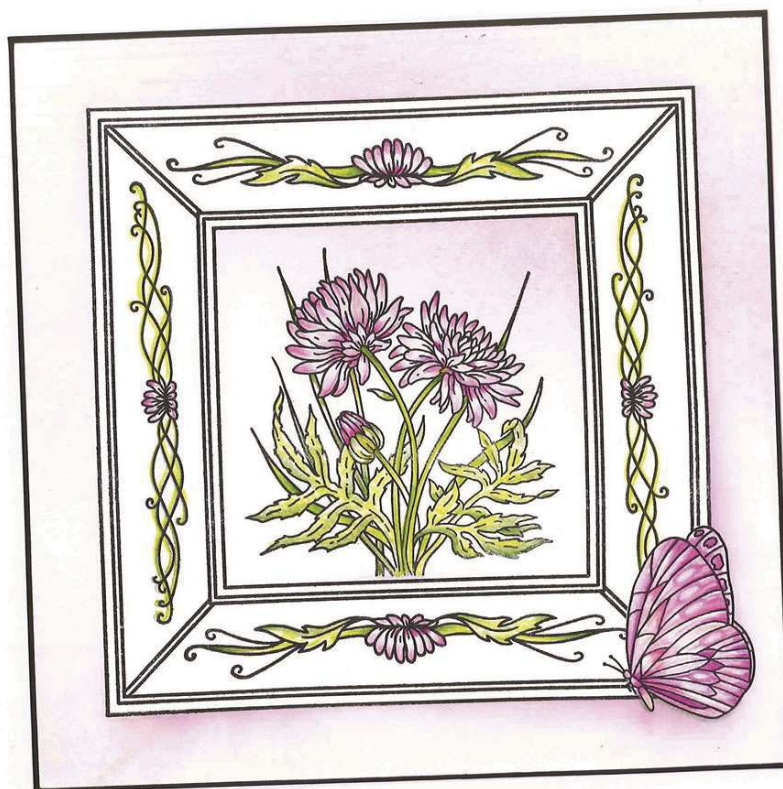

### Shopping list

Perga Liners – Combi Box, £29.99;  
Jayne's Dahlias Unmounted Stamp  
Set, £19.99; Jayne's Frame  
Unmounted Stamp Set + 7x7 Mega  
Mount, £19.99; Clarity Stencil  
Brushes, £19.99; New England Fall  
Designer Paper Pack 8x8, £12.98;  
Garden Heart and Verse Unmounted  
Clear Stamp Set, £12.78; 7x7 Stencil  
Card, £7.98; 8x8 Card Blanks &  
Envelopes x10, £4.50

#### From Claritystamp

Cotton Candy and Fancy Fuchsia  
Artistry inks; coloured pencils, black  
Sharpie, makeup sponge, sticky notes

#### From your local craft shop

For stockists turn to page 91

### Essential toolkit



Jayne's Frame Unmounted Clear  
Stamp + 7x7 Mega Mount  
£19.99



Jayne's Floral Unmounted  
Stamp Sets  
£19.99 each

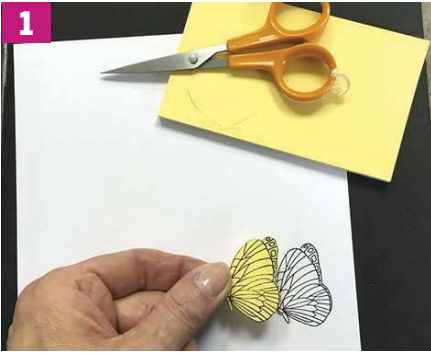

**1** Decide where the butterfly will settle on the frame, and stamp it onto a 7x7 stencil card in black ink. Stamp it again onto a sticky note and cut out to create a mask.

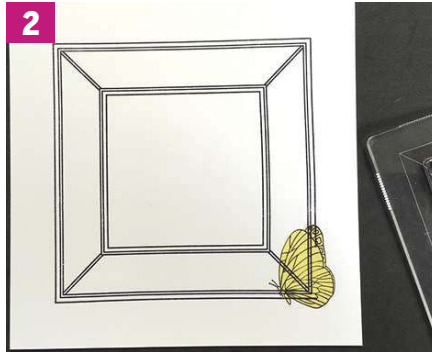

**2** Position the mask over the butterfly, and stamp the frame in black over the butterfly. With large stamps, I use the soft black Groovi mat underneath for a clear image.



**3** Stamp Jayne's perfectly designed floral centrepiece to sit inside the frame. Each set comes with floral trails to decorate the sides of the otherwise plain frame, too.



**4** Time to add colour! I used the Perga Liners coloured pencils. I like this set because it houses a combination of waxy pencils and watercolour pencils. I used both.



**5** Make a mask to cover up the whole of the frame itself, using low-tack masking tape, as we'll add a bit of shading, but want the frame to stand out.



**6** Use a Clarity Stencil Brush with a combination of Artistry inks. I used Cotton Candy, then added Fancy Fuchsia. Simply sweep back and forth across the page.



**7** To add a drop shadow under the frame, use a makeup sponge with Fancy Fuchsia ink and light feathery strokes starting on the tape and moving out towards the paper's edge.



**8** Once you remove the mask from the frame, you see how much colour you have actually applied! If you're happy, you can now remove the butterfly mask as well.



**9** Trim the card back, and drag a black Sharpie around all four sides. It is fast and neat; just put copy paper underneath, and don't hesitate! If you prefer, use a ruler.

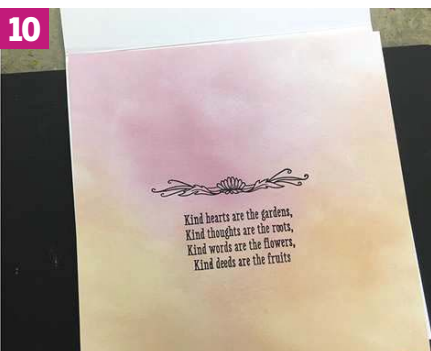

**10** For the inside of the card, stamp a sentiment onto a piece of paper to match. I used the Garden Heart and Verse stamp set on New England Fall Designer paper.



**11** Finally, mount your floral artwork onto the front of an 8x8 white base card. Attach the insert to the inside top edge with double-sided tape to finish!

## There's more...

Be sure to visit Claritystamp online at [www.claritystamp.com](http://www.claritystamp.com) and [www.facebook.com/claritystamp.co.uk](http://www.facebook.com/claritystamp.co.uk). Plus, see Barbara on crafting TV channel HOCHANDA (Sky 663, Freeview 85 and Freesat 817) the first Sunday of every month.



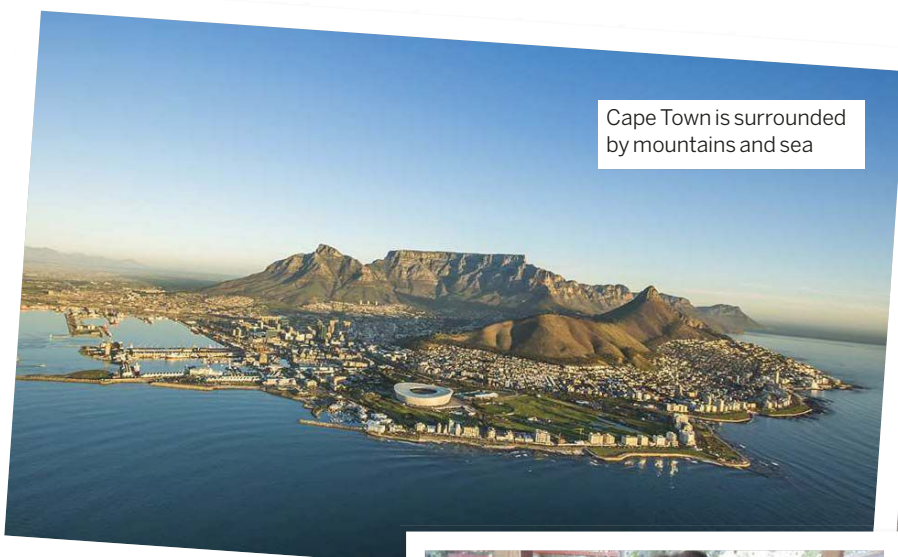

Cape Town is surrounded by mountains and sea



Michelle and her students at an Easter basket making class

# Cardmaking in South Africa

South African cardmaker Michelle Anders tells us about her close-knit cardmaking community and sharing her love of craft with a younger generation

As told to **Sienna Parulis-Cook**

**M**y name is Michelle Anders, and I'm a cardmaker living in the beautiful city of Cape Town, South Africa. I love the greenery of walking down a street here, and I can drive about 15 minutes to my nearest beach. We are surrounded by mountains, and when you travel outside and are driving back, you know you're home when you see Table Mountain – one of the seven Wonders of the World – and the sea in the distance. It is such a beautiful view! No matter where you are in Cape Town, you can have four seasons in one day. I love the slang in our different communities, culture and most importantly the variety of food.

I've been making cards for nearly 20 years. In the late 1990s, I remember

seeing cards with gold embossing and wanted to learn how to do that. Then in 1997, I walked into a craft store selling rubber stamps. I immediately put my name down on their waiting list, and my first cardmaking class was in January 1998. Before cardmaking, I was always interested in other crafts and did various workshops such as fabric painting, candlemaking, beading and découpage – I think I was finding myself, but nothing caught my attention like cardmaking.

In my circle of family and friends, I am the only one doing cardmaking, although a few do other crafts like knitting, crochet or sewing. But I also have a community of cardmaking friends – the ladies I met when I began cardmaking, and a Yahoo group that

I started in 2002. Our cardmaking community supports each other – we recently visited an opening of a scrapbooking shop, Be Love Creations, which is around a 20-minute drive one way, and quite far by Cape Town standards! I also like to visit my friend Shamela Hendricks' shop, Kanje Krafts & Kreations, which caters to scrapbookers and cardmakers.

Michelle teaches a craft class to kids of all ages, twice a month



*“You know you're home when you see Table Mountain and the sea in the distance”*



Michelle's RSA Yahoo group get-together at Kanje Krafts & Kreations

## scrap-it design studio



## “South Africa also has its own crafts and designs, and this diversity of design in our country is great”

There are people in South Africa who buy shop-bought cards. However, they are expensive and generally bought for only for special occasions. Handmade cards are cheaper and can be personalised. Sadly, due to our postal strikes in the past, cardmakers are wary of posting cards, but the system is improving and we do hand deliver as well. Amongst cardmakers, we will post registered and this way we know our cards will be received.

Although there are crafters in South Africa who use stamps, dies, embossing folders and other techniques similar to those you see in Europe or North America, and there is amazing talent (and teachers) here, our hobby is considered a luxury, as certain goods are imported and expensive for some households. As a result, there is another kind of South African cardmaker who will use their printer for wording, handmade paper, stickers and embellishments to make cards. Our exchange rate definitely curbs my shopping, as well, making sure that what I buy can be used often and I am getting my money's worth. Of course, South Africa also has its own crafts and designs, such as African designs using beads and wire, and this diversity of design in our country is great. It would be boring if our creativity was the same, I think.

Another challenge is that we are in the Southern Hemisphere. When I started buying rubber stamps, I would

buy winter-themed Christmas stamps. Then another cardmaker pointed out to me that we have a summer Christmas, and since then I don't buy winter-themed Christmas cards and look at stamps differently, especially if they are not suitable for our country.

Scrapbooking is quite popular in South Africa, and we have a local scrapbooking magazine called *Scrap Affairs*. We also have some of our own brands for scrapbooking materials and other papercrafting supplies, including Fab Scraps, Lady Pattern Paper and Ivytree Studio.

Most of us cardmakers get our inspiration from Pinterest and YouTube, and our scrapbooking shops do offer scrapbooking and cardmaking classes as well.

A few years ago, I was a craft facilitator for disabled students, and this is where I started to think about using recyclable items for crafts. I look at packaging differently now and am always thinking of a craft idea. Last September, I started to teach Saturday craft classes for kids of all ages, and the focus is using items in your home. I started off with origami boxes and flowers, and now the kids can make a box for any occasion using any kind of paper in their home. We will be using old buttons, tins and plastic bottles for future projects.

I also started a group called Crafting for a Purpose – here, the ladies bring along their latest craft projects, and I



Michelle's parents, niece and nephew visiting Scrap-It Design Studio in Port Elizabeth (top); Michelle with Scrap-It owner Elizna Van Lill Parsons

teach them the same class I do with the kids. These ladies are also craft facilitators, so we are all giving back in our communities. Since September 2016, I have shown six project ideas using any size square paper and introducing the ladies and kids to patterned scrapbooking paper. My focus, however, is using recyclable items to draw on our own resources.

Like every country, we have our challenges in South Africa, but I do think this makes one appreciate what we have even more, and also helps us to be more creative when it comes to our choices of crafting materials and cardmaking designs!

### Share your story

We'd love to hear from you! If you have a cardmaking story you'd like to share, email [writetous@cardmakingandpapercraft.com](mailto:writetous@cardmakingandpapercraft.com)

# Chameleon Color Tones

*Hazel France shows you how to use the Chameleon Color Tone Pencils for some fabulous shading to create this pretty card*

**Project:** Your guide to Chameleon Color Tones

**Time:** 1 hour

**Expert:** Hazel France



Hazel has been cardmaking for over 15 years and her favourite techniques are stamping and distressing, not to mention colouring! This month she's experimenting with Chameleon's new Color Tone Pencils to bring you an excellent step-by-step guide to shading a beautiful lily!

**H**ave you ever wanted to have a play with pencils but just don't know where to start as there are so many different colours to choose from?

Well, let me introduce to you the new Chameleon Color Tones Pencils. These have been specially designed to take the guesswork out of having to choose from all those different colours for blending and shading as each pencil is split; one colour is at one end and its perfectly matching partner is at the other. No more trying to figure out which colours go together, which will give you more time to be creative.

These pencils are artist quality and are highly pigmented, plus they've been specially designed for the smoothest of blending. While there are 25 pencils in the range, giving you 50 different colours, you can expand this even more by applying a different pressure each time you colour, adding even more tones to your collection.

Don't be afraid to experiment on different surfaces, from smooth card to a more textured medium such as watercolour paper. Each surface will give you a different result, but remember that the texture will affect how easy it is to blend and layer colours together.

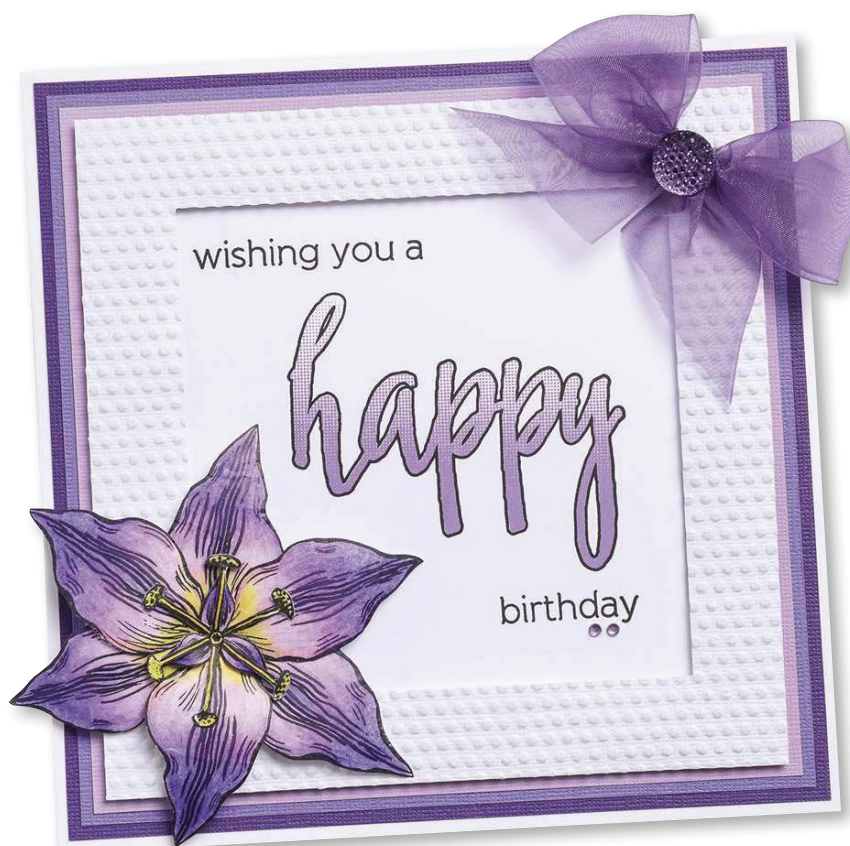

## Shopping list

Chameleon Pack of 25 Color Tone Pencils, £49.99

**From Create and Craft**

Sheena Douglass A Little Bit Floral A6 Stamp Set – Lily Stamp, £4.99

**From Crafter's Companion**

Die-cutting machine, embossing tool, dotty embossing folder, large sentiment stamp, three shades of lilac card, lilac ink, sheer lilac ribbon, lilac rhinestone sparkler, lilac gems

**From your local craft shop**

**For stockists turn to page 91**

## Hazel's top hints & tips

- ★ Blend your colours from light to dark; that way you have more control of the area you want to shade and the depth of the colour you are looking to achieve.
- ★ Don't think there are only two colours to each pencil – the more pressure you apply, the darker the colour you will achieve.
- ★ Try blending two completely different colours together. Experiment and you'll be

surprised by some of the different shades you can create.

- ★ If you can, carefully use a small craft knife to sharpen your pencils, as this will not only save your precious lead, but will also allow you to create sharper lines and get into the most detailed of areas.
- ★ Remember to gently wipe away any lead dust that may be on your work with a soft tissue regularly, as this may become attached to your hand or fingers, and can then spoil your project.



**1** Stamp the lily image onto a piece of smooth white card using black ink. Take the Lemon Peel pencil and start to colour the centre of the flower. Flip the pencil over to Grapefruit and shade the section until you are happy with the colour.



**2** Take the Pink Orchid coloured pencil and, starting from the top of the petal, gently layer the colour all the way down to the yellow section. Lightly colour over the yellow edge with this colour to help it blend together.



**3** Flip the pencil over, and using the Thistle end, start to colour from the top of the petal down towards the centre. Colour around the inner edges and stop approximately half of the way down, as shown.



**4** Take Heather for the darkest colour and start at the top of the petal, bringing the colour into Thistle. To smooth the two colours, take Thistle and use small circular motions to gently blend the colours together until you are happy with the result.



**5** To bring all the colours together seamlessly, take Pink Orchid and, starting from the top, go over all the colours down to Lemon Peel. Once you are happy with the finished image, repeat from the beginning on a second stamped image.



**6** Stamp the central section of the lily, and colour using the same colours and technique as above. For the stamen, start from the centre with Grapefruit. Three quarters of the way up, flip your pencil over and finish with Lemon Peel.



**7** Once you are happy with all the coloured parts of the flower, carefully cut out each image and shape using a large embossing tool. Attach the layers together, as shown, to create a beautifully coloured lily.



**8** Layer three shades of lilac card onto a 180mm square base. Stamp a sentiment onto a 150mm square of white card and attach. Add a 160mm square embossed frame with sticky fixers. Attach the lily, a bow, rhinestone sparkler and gems.



Subscribe to Cardmaking & Papercraft today and receive your own set of Chameleon Color Tone Pencils!  
See p32

## 1 Window and window box

- 1 Attach a 135mm square of wood effect paper to a 140mm square white base card. Die-cut a window with an arch from white card. Add patterned paper to the reverse and attach to the centre of the base card.
- 2 Die-cut the window box, flowers and four pieces of foliage from white card. Colour with pencils and add pearls to the flowers. Assemble the window box and flowers and attach below the window.
- 3 Add two pieces of foliage at the top of the arch and two to the sides of the window box. Die-cut five small butterflies and attach as shown, to finish.



### Shopping list

Creative Expressions Kinetics: 3D Window Box and Accessories die set, £13.04; Arched Window/Door die set, £8.72; Window Shutter and Valance die set, £5.30

#### From Sunrise Crafts

Trimcraft First Edition Sweet Nothings 6x6 paper pad, £7.99

#### From Hobbycraft

Die-cutting machine, banner die, coloured card, acetate, colouring pencils, pearls, letter stamps or computer/printer

#### From your local craft shop

For stockists turn to page 91

# 5 ideas with... windows

Look out for these fun cards made using window dies and **Ruth Hamilton's** design inspiration

## 2 Black and white cats

- 1 Attach a 135mm square of navy spotty paper to a 140mm square white base card. Die-cut the rectangular part of the window and the sill from the window die, both from white card. Attach together. Cut two 15x70mm pieces of striped paper and add behind each side of the window to form curtains. Add a 50x70mm rectangle of floral patterned paper behind. Attach to base centrally.
- 2 Use the offcuts from the window panes to die-cut 'bricks' from navy patterned paper. Attach seven with sticky fixers around the top and sides of the window, as shown.
- 3 Die-cut two round topiary trees, colour with pencils and add gold pearls. Attach one to each side of the window with sticky fixers. Die-cut one black and one white cat and attach below the window to finish.

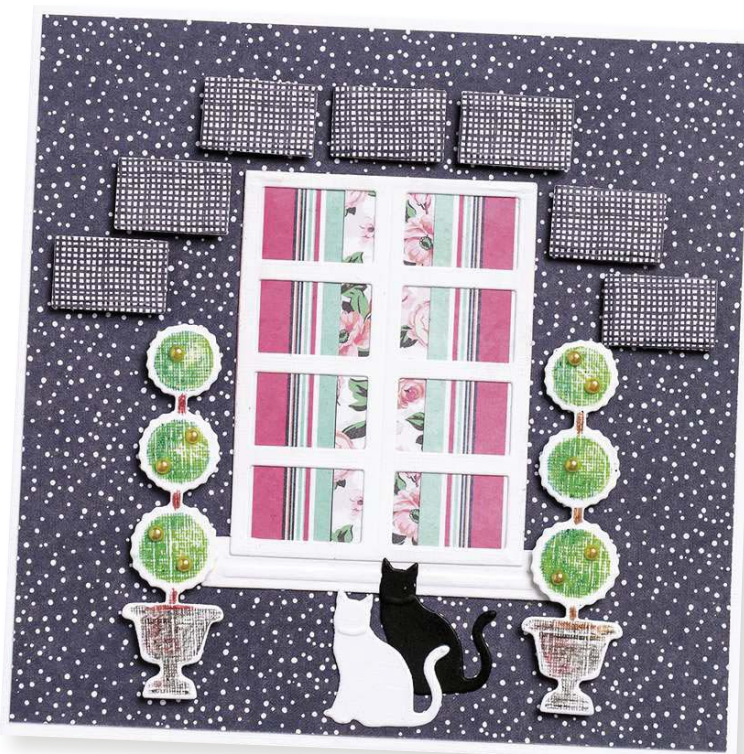

### 3 Florist shop

- 1 Attach a 135mm square of navy patterned paper to a 140mm square white base card. Die-cut the rectangular window die, excluding the inner frame, from black card, then die-cut the inner frame from white card. Attach acetate behind the white frame.
- 2 Die-cut the flowers from the window box, two pieces of foliage and three flower pots. Colour with pencils and attach to the black window. Add the white window frame on top and attach to base.
- 3 Die-cut two topiary trees from white card and pots from black card. Colour the trees and attach to either side of the window with sticky fixers. Print or stamp the word 'Florist' and die-cut with a banner die. To finish, attach above the window with sticky fixers.



### 4 Side curtain

- 1 Attach a 130mm square of floral paper to a 135mm square of aqua paper and a 140mm square white base card. Cut a 130x10mm strip of white card, emboss a fine line across the top and bottom and attach 40mm from the bottom of the base.
- 2 Die-cut the rectangular window and a topiary tree from white card. Colour the tree and attach to the reverse of the window. Add a rectangle of pale blue card behind. Attach to base. Add a 60x20mm strip of peach paper just overlapping the top of the window, then die-cut the valance from the same paper and attach below the strip.
- 3 Cut a 105x60mm piece of aqua paper; score and fold concertina-style every 5mm along the 60mm length. Die-cut another peach valance, attach around the centre of the curtain and trim. Add the curtain to the left side of the window. Die-cut a white cat and attach with sticky fixers.



### 5 Window and shutter

- 1 Attach a 135mm square of wood effect paper to a 140mm square white base card. Die-cut the window pieces, valance and shutters from white card. Attach a semi-circle of aqua paper to the inside of the window arch and triangles of the same paper to the inside of the window to make curtains. Add a 60x20mm strip of white card at the top behind the curtains and attach the valance below. Add a 60x70mm piece of floral paper at the back.
- 2 Attach the window to base. Add the shutters with double-sided tape to the window edge and sticky fixers on the outside edge.
- 3 Die-cut flowers from the window box using patterned paper and attach at the corners of the window. Add pearls in the centres. Die-cut the bird and foliage, colour with pencils and attach using double-sided tape and sticky fixers, to finish.



# The Hub

Looking for new ideas, challenges and chat? Then log on and join us

## Facebook

Like us on Facebook to keep up with competitions to win fantastic prizes, download exclusive free papers, share ideas and meet fellow papercrafters [www.facebook.com/cardmakingmag](http://www.facebook.com/cardmakingmag)

## Chat

**Here's what you've been sharing with us on Facebook...**

It's not often I get to buy your magazine as I live in Swaziland. However, when I do get my hands on one it is such a treasure. I've made many cards following the techniques and I especially enjoy browsing for inspiration. Thank you for your creative magazine.

**Beverly Marx**

Thank you so very much for the amazing free gift from issue 169! I love that it comes with changeable blossom, leaves and hearts for the trees. The clouds are great for building scenes, too!

**Fiona Bacon**

## Friday Challenge

Each week there's a brand new chance to win a lovely craft prize – from stamps to papers and dies to machines! Recently, we gave away this fabulous My Mind's Eye In Bloom collection, including papers, chipboard pieces, enamel dots and more. Visit us on Facebook now and enter for your chance to win a lovely prize!



**Check out our Facebook page for weekly challenges, projects & more!**

## BLOG OF THE MONTH

Be inspired by our pick of the best craft blogs around. This month we love...

[www.pinkanddotty.co.uk](http://www.pinkanddotty.co.uk)



**Meet Wendy, the owner and creator of the fantastic Pink and Dotty blog. Wendy was inspired to start crafting by her mother, and once she started cardmaking, she was hooked! You'll find a variety of imaginative and beautiful cards at Pink and Dotty, so visit now for her fabulously fun ideas and inspiration!**

## Website OF THE MONTH

Each issue we show you the best websites to visit for plenty of papercrafting inspiration

[www.onlinecardclasses.com](http://www.onlinecardclasses.com)

Why we love Online Card Classes...

- ★ Clean and simple – if you're just starting out, you'll find loads of clean and simple card design tutorials to help you get a hold of the cardmaking basics!
- ★ Techniques – If you're struggling with a particular technique, you'll find helpful tutorials here that will guide you through your chosen skill.
- ★ Stretch your supplies – You'll find out all the tips and tricks for becoming an economical crafter by stretching your stamps, dies and papers!

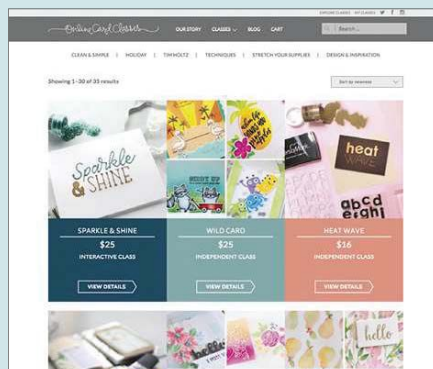

## Get inspired!

Visit our Pinterest page at [pinterest.com/cmpcmag](http://pinterest.com/cmpcmag)



**It's summer and we're loving these fun and fruity cards. Check out our Pinterest for more exciting designs!**



## Milestone moment

Follow us on Instagram for exclusive behind-the-scenes glimpses, crafty giveaways, the *Cardmaking & Papercraft* team's very own card creations, cardmaking inspiration and even your makes, too. This month we hit our first Instagram milestone, reaching 1,000 followers! We've loved seeing all your makes, tagged using our #cardmakingmag, and can't wait to see more creativity that is yet to come! Thank you to each and every one of our readers and followers for all your fantastic support. Happy crafting!



Follow us @cardmakingmag

## APPS TO GO!

Now you can take your copy of *Cardmaking & Papercraft* with you wherever you go!

Our fantastic apps are available at the Apple Newsstand, on Google Play, Zinio and via Amazon on Kindle Fire. Buy single issues or subscribe for amazing discounts. It's all your usual inspiration in pocket size!

Take us with you!



## Win prizes!

### Enter our online cardmaking challenge!

This month we challenged you all to make your most delicious baking-themed crafts, and we were astounded with the amount of delectable designs. Our winner this month is Christine Bilyard, who entered this fabulous afternoon tea card! We love all the beautiful details, such as the golden clock, pretty



butterflies and lace elements. What a gorgeous creation!

Tick tock goes the clock – we love the spoon and fork hands



Tune into our YouTube channel for helpful tutorials! Recently, we shared videos showing how to make fun pop-up cards and more from this issue!

[www.youtube.com/CardmakingMag](http://www.youtube.com/CardmakingMag)

Tweet it

@cardmaking\_mag



## Free DESIGNER PAPERS

from [www.cardmakingandpapercraft.com](http://www.cardmakingandpapercraft.com)



To download visit [www.cardmakingandpapercraft.com/download/free-february-facebook-designer-papers](http://www.cardmakingandpapercraft.com/download/free-february-facebook-designer-papers)

To download visit [www.cardmakingandpapercraft.com/download/issue-167-free-gift-digi-papers](http://www.cardmakingandpapercraft.com/download/issue-167-free-gift-digi-papers)

Download for free

from [www.cardmakingandpapercraft.com](http://www.cardmakingandpapercraft.com)

For free downloads, tips and many more cardmaking ideas, visit [www.cardmakingandpapercraft.com](http://www.cardmakingandpapercraft.com)

132 PAGES OF ON-TREND STITCHING DIYS AND INSPIRATION

Mollie  
MAKES

149 INSPIRING IDEAS & MOTIFS FOR  
EVERYONE, EVEN BEGINNERS!

# EMBROIDERY

YOUR COMPLETE GUIDE • DIYS FOR HOME, FASHION & KIDS

29 FRESH  
PROJECTS



INSIDE: SUBLIME STITCHING • SEÑORITA LYLO •

JUST  
£8.99!\*

The team behind *Mollie Makes* brings you a **collection of embroidery** projects and ideas for your **home**, your **wardrobe** and the **little ones in your life**. Perfect for beginners and seasoned stitchers alike, it's **packed with DIYS** for embroidery in hoops, **on banners**, on denim... and more!

**ORDER YOUR COPY TODAY!**

Call 0844 844 0388 and quote 'Mollie Embroidery'

Online [www.buysubscriptions.com/craftspecial](http://www.buysubscriptions.com/craftspecial)

Lines open weekdays 8am to 8pm and Saturday 9am to 1pm. Overseas please call +44 (0) 1795 414 676.

\* EUR price £11.99, ROW price £12.49. All prices include p&p.

## 1 Colour resist

Colour resist is a clever technique where dye-based inks don't stick to the VersaMark ink, creating a subtle contrast. I found that Distress Inks give a more even coverage than Archival inks. For this card, I stamped the greeting and seed heads onto gloss paper in VersaMark ink, then brayered over Scattered Straw, Worn Lipstick and Spiced Marmalade Distress Inks. Roll the brayer until the ink is smooth; you can wipe off excess with a tissue.



## 2 Heat embossing

VersaMark is the best type of ink for heat embossing. As it is clear, even pale embossing powders will show up as pretty, clean colours. To make the trees, stamp small flowers onto green paper, sprinkle with pastel pink embossing powder, tap off excess and emboss with a heat tool. Repeat to stamp and emboss three small butterflies on orange card. Stamp flower stems onto pink card, and use a VersaMark pen to 'colour' the petals and heat emboss in pink.

## 3 Watermark

Create a watermark effect by stamping with VersaMark on plain card. You'll get the best results from a smooth absorbent card in a dark shade. You can also create a raised effect by heat embossing the VersaMark with clear powder. Here, I've used VersaMark ink to repeatedly stamp dark green card with the word 'love' and flowers, and stamp light green gloss card with butterflies which I then coloured in. I cut the green panels into strips and alternated them to create a striped pattern.



# 6 ways with... VersaMark ink

It's not just for heat embossing! **Dorothy Wood** shows how versatile this ink can be



“VersaMark is a versatile pigment ink that should be in every cardmaker's stash. This slow-drying, viscous, sticky clear ink is ideal for heat embossing, 'no-line' stamping, creating two-tone or shaded effects with chalks, achieving subtle resist patterns and watermarks using stamps, and more.

Sponge or dab the ink to create a distressed background, or use a brayer for a smooth finish. VersaMark is available as a pen or ink pad, and you can also buy a re-inker to replenish. ”

## 4 Pastel background

PanPastels are large blocks of chalk that can be used to colour backgrounds with a sponge, giving an impressive even cover. Stamp with VersaMark ink first, and you'll achieve a subtle two-tone effect. Here, I've stamped flowers, stems and words onto white card with VersaMark ink and also added dots with a VersaMark pen. Then I coloured over the card with pink, orange and yellow PanPastels to create patterned papers.



## 6 Chalk images

Chalks stick to VersaMark ink, as it has a sticky consistency. This creates a subtle shadowy effect, as even with a cotton bud you will put some colour on the background. The colour is darker on the VersaMark than on plain paper. Here, I've stamped flowers onto white card in VersaMark, and used cotton buds to carefully colour the flowers with pink, orange and yellow chalks. Add dark green to the dots. The butterflies are also stamped in VersaMark and coloured with chalks.



## 5 Pastel effect

By stamping with VersaMark ink and heat embossing with clear powder, you create a softer, more painterly effect than stamping with black ink. The heat embossing also makes it easier to keep within the lines when colouring. Here, I've stamped the flowers and butterflies in VersaMark, heat embossed with clear powder, and coloured with pale pastel ProMarkers. I then coloured over the ball flower with yellow chalk, and finished by stamping, heat embossing and colouring one butterfly to trim and attach on top of the sentiment strip.

OVER  
**£25**  
WORTH OF  
CARDMAKING  
GIFTS INSIDE

# make special Cards

NEW  
2-IN-1  
CARDMAKING  
PACK

Make beautiful cards for all your summer celebrations with this fantastic pack, worth £25

OVER **£25** WORTH OF CARDMAKING GIFTS INSIDE

**EASY CARDMAKING 156 FAB GIFTS INSIDE**

SEE INSIDE! PRETTY CUT-OUT AND STICK SENTIMENTS

the **REALLY SPECIAL SERIES**

NEW ISSUE

SUMMER 2017 ISSUE 8

**make special Cards**

ALL YOU NEED TO MAKE BEAUTIFUL CARDS FOR ALL OCCASIONS

**YOU GET ALL THIS...**

- \* Patterned papers
- \* Die-cut toppers
- \* Beautiful clear stamps
- \* Quality card blanks
- \* Matching envelopes
- \* 52-page magazine

Start making cards today!

**YOUR LUXURY POP-OUT & STICK PACK!**

- 30 PATTERNED PAPERS
- 88 DIE-CUT TOPPERS
- 18 CLEAR STAMPS
- 10 CARDS & ENVELOPES

**MAKE CARDS USING YOUR GIFT PACK!**

MAKE SPECIAL CARDS £9.99  
IMMEDIATE MEDIA 0.8  
9 772057 189014

**50 CARD & TAG IDEAS! BIRTHDAYS, ANNIVERSARY & MORE**

**BEST WISHES**

**HAPPY BIRTHDAY**

**SPECIAL THANKS**

**MILESTONES**

Our pack is bursting with cardmaking goodies, plus a fab magazine with over 50 ideas for cards and tags you can make straight away!

Whatever occasions you're marking this summer, you'll be inspired to make gorgeous cards with this fantastic 2-in-1 pack. Create stylish greetings with our floral watercolours collection featuring elegant flowers and foliage. Or, go super-sweet with our adorable mice – they're nestling in plant pots and hiding in posies!

## LOOK AT WHAT YOU GET!

- \* 88 die-cut toppers
- \* 30 pretty papers
- \* 18 clear stamps
- \* 10 cards and envelopes
- \* 52-page magazine packed with projects

**PRE-ORDER YOUR COPY NOW!**

CALL 0844 8440388 and Quote "Really Special 8"  
Online [www.buysubscriptions.com/craftspecial](http://www.buysubscriptions.com/craftspecial)

Lines open weekdays 8am to 8pm and Saturday 9am to 1pm. Overseas please call +44 (0) 1795 414 676.  
EUR price £12.99, ROW price £13.99. All prices include p&p. Please allow up to 14 days for delivery.



## This month's Experts

### Simonne Clay

Simonne is an experienced crafter with a wealth of knowledge to share with you! She's always ready to test out the latest ideas – this month, she shares expert tips on stamping with white ink.



### Deb Ellis

One of Hunkydory's talented design team members, experienced crafter Deb, is on hand this month to help out with découpage dilemmas and special card suggestions for all occasions.



### John Lockwood

From crafty blogger and demonstrator to a Creative Expressions designer, John is an expert in all things handmade. This month he has some fab tips for quality glues and embossing.



### Dorothy Wood

Dorothy is an experienced crafter who loves trying new techniques. She's written over 20 books on papercraft, beading and textiles and has become a well-known crafting expert.



# Crafter's Q&A

Put your crafting questions to our team of top experts

I like making découpage scenes but find that they can get very bulky and difficult for posting. Do you have any advice?

**Molly Adams, Norfolk**

**Deb says:** There are a couple of things you can do to reduce the bulkiness. You can use our Hunkydory Imm sticky fixers, which still give some depth but reduce the thickness considerably if you are wanting to post your card. You can also cut down on the layers of découpage you use if you want to make the card thinner still. This card from our Primrose Lane collection has been made using the thinner sticky fixers and it still looks gorgeous! The cottage itself is two layers on top of the base, while the garden has up to six layers, plus the fence. Even with all these layers, the card is only 7mm thick – perfect for posting!



Sometimes, when I use certain embossing folders, I get lines on my card from the edge of the embossing folder. Is there a way to prevent this?

**Julie Waters, London**



**John says:** You can always avoid lines from your embossing folders by making sure that the embossing sandwich leaves the edge of the folder overhanging the plates in the machine. Where the card overhangs the folder and the plate goes over this, you do often end up embossing a line into the card. The best solution I find is to cut the embossed piece to size and place inside a larger folder than the required embossed layer. This will give neat clean embossing edge with no lines or edge marks. You can repeat a pattern on a smaller folder by again making sure the edge of the folder hangs over the embossing sandwich. I've used these techniques on this embossed card here!

Turn the page for more advice from our experts



Write to us...

By post

Q&A, Cardmaking & Papercraft,  
Immediate Media Co Bristol Ltd,  
2nd Floor, Tower House, Fairfax Street,  
Bristol BS1 3BN



Email us

writetous@  
cardmakingand  
papercraft.com



Instagram

Find us on Instagram at  
@cardmakingmag, and don't  
forget to tag your photos with  
#cardmakingmag



Tweet us

@cardmaking\_mag



## 5 TIPS FOR USING PUNCHES



**1** Turn the punch upside down when you're using it so you can see the area you're cutting out.

**2** If the punch starts to become dull, punch a piece of tinfoil several times to sharpen the cutting edges.

**3** Use just part of your punch to create different effects. For example, use part of a scalloped circle punch to make a square with a curved decorative edge.

**4** Regularly clean out the paper and card scraps from your punch to stop it from jamming up.

**5** Keep the pieces you punch out from and use them as scrap card or embellishments for other projects.



I often make cards using glue, but it makes my card wrinkly. Should I be using a special kind?

**Adam Fennell, Brighton**

**John says:** There are two main reasons for card warping when using wet glue. Standard PVA or school glues use a great deal of water in the formulation, which can then swell the card, causing lines and warping. The best remedy is to use a specialist craft glue such as Cosmic Shimmer Dries Clear Glue, which is an acrylic-based craft glue that does not contain this high quantity of water. The second reason is that simply too much glue is applied. Use glue sparingly. A thin layer of a good specialist glue will stick without warping your card.



I can never get my images stamped with white ink to show up very well. I'm using standard Kraft card and a quality white ink. Do you have any ideas of what am I doing wrong?

**Amy Cooke, Exeter**

**Simonne says:** There are so many white inks available on the market with varying opacities, so it is difficult to know which is best. Different inks react differently to different stamping surfaces as well. When deciding on which white ink is best for your needs, check out YouTube for ink comparison videos, and also experiment with different inks and surfaces yourself. No matter which ink you choose, stamping with white ink will always give a more muted, rustic effect. However, if you repeat stamp the image multiple times, allowing the ink to dry between stamping to provide a 'key' for the next layer, you can build up the layers of ink to a good opacity. The best type of ink for this technique is pigment ink, however



these inks are slow to dry. My favourite white ink is Memento Luxe Wedding Dress ink as it can be quickly heat set with a heat tool to make it permanent so that it doesn't lift off or smudge. For my card, I used a stamp positioning tool to repeat stamp the foliage and sentiment three times to build up the layers of ink and achieve good opacity. I heat set each layer of ink between stamping to provide a key for the next layer, ensuring that the second and third layers of ink didn't absorb into the card.



We think this stamp set from Creative Expressions is just dino-mite! Featuring 13 roarsome stamps, you'll have lots of fun creating cards for your dinosaur-mad friends and family! Choose from three terrifyingly cute dinosaurs, four sentiments and extras like an empty egg, steaming volcano and suspicious footprints – just think of the papercraft drama you could create!

Creative Expressions Dinosaur Friends Stamp Set, £10.89, [www.craftasmic.co.uk](http://www.craftasmic.co.uk)

I forgot a good friend's birthday and I feel terrible! Do you have any ideas for a nice card to say sorry?

**Rowan Dent, Weston-super-Mare**

**Deb says:** This cute kitten topper set from the Hunkydory Special Days collection is the perfect way to say sorry. I am sure she will forgive you once she sees that little face! Simply layer the foiled kitten image onto a 150x210mm piece of gold mirri card and add to a base card. Then add the matching kitten topper and 'I'm sorry' sentiment with sticky fixers, and finish with a few gems.



This collection comes with papers and toppers for all occasions!

Sometimes my dies and embossing folders have sticky residue on the back when I remove them from the packaging. What's the best way to clean this off?

Sarah Sharp, Edinburgh



Did you know vinegar can remove sticky residue from your dies?

**Dorothy says:** Manufacturers often use adhesive tape or a glue dot to hold embossing folders and dies in place, and the sticky residue can damage papers when you use the items. Vinegar is cited as a good way to clean adhesive residue, especially if you are allergic to petrol-based products, but a solvent is quicker as it dissolves the adhesive. Some people suggest using acetone-based nail polish remover, but there are lots of products on the market including Goo Gone, De Solv It and Sticky Stuff Remover from Betterware. These products all have good reviews – I use De Solv It as I like the gel formula. Apply with a ball of cotton wool rather than a tissue, leave to soak for a few minutes, then wipe off. These products are also useful for cleaning scissors. Goo Gone is available online from Amazon and De Solv It from high street stores such as Halfords and Tesco.

## Your tips & advice...

We love sharing tips on our Facebook page, and we've recently been talking about applying colours onto the stamp, then stamping the image as normal to get more from your stamps

★ I find that this works best with water-based markers, and not alcohol markers. Huffing on the stamp will also help to re-moisten any ink that's dried while colouring other parts of the stamp. Candy Clouston

★ I've coloured my stamps with Sharpies before stamping them. Helen Walsh

★ Be sure to work quickly when colouring your stamps or else the colours may start to dry before you get to stamp the image onto your card. Becca Schutizus

## Where can I find...

### ... a DIY party crafts tool?

It's time to get your summer party crafts hat on, and you can make your very own with the help of this fabulous DIY Party Board from We R Memory Keepers. Create cute party hats, ice cream cone holders, cake decorations, party bags and so much more with ease! You'll certainly be the host with the most this summer!

We R Memory Keepers DIY Party Board, £20.35, [www.crafttelier.co.uk](http://www.crafttelier.co.uk)



### ... a summer bicycle die?

We love this cute bicycle die set from Sizzix. It's perfect for summer crafting, and you'll have lots of fun creating an abundance of summer cycling scenes. The set comes with three pieces – the bicycle, flower and heart dies. This set will help you create beautiful cards for birthdays, weddings, or even just because. Why not create a field of flowers hidden in the middle?

Sizzix Three-Piece Bicycle Die Set, [www.hobbycraft.co.uk](http://www.hobbycraft.co.uk)

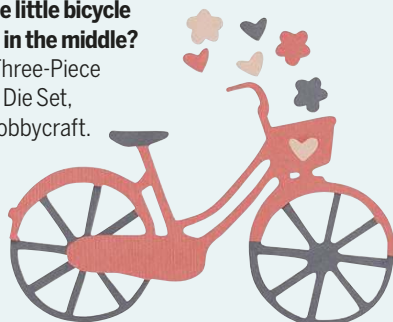

Punches shouldn't be overlooked!

As my papercraft stash gets larger, I was wondering if there were certain punches that every cardmaker should have in his or her stash. What punches are most useful? Could you make a card with some basic punches, please?

Riva Varma, Salford

**Dorothy says:** Punches have been slightly forgotten with die-cutting being so popular, but I find them so quick and easy to use. Basic shapes such as circles, hearts, butterflies and flowers are so useful for adding little details to your cards. I have several sizes of square punches. You'd think, why not just cut the squares? But punched squares have slightly softer corners that makes such a difference to the finish! Circles are great for layering, as a background for greetings or a few punched flowers, as shown on this retro card. To make the card, punch squares in two sizes and lay out on the base card. Punch circles and arrange over the squares. Draw around the circles, punch the sections out, then stick the squares down, raising the circles with sticky fixers. Add a greeting and finish with a dashed line.



Tweet or text us your tips

Tweet your top tips, crafty questions and comments to @cardmaking\_mag Text CMPCED followed by your message to 87474. Texts charged at 50p plus your standard network rate.\* Please include your name and address in case your message is printed.

\*Please note, we cannot reply to text messages. For customers on contracts, texts to shortcodes are generally not included in SMS bundles. By texting us you are agreeing to receive details of future offers and promotions from Immediate Media Company Bristol Ltd. Your details will not be passed on to third parties. If you do not want to receive this information please add the words 'NO INFO' at the end of your text message.

# TRY 3 ISSUES FOR JUST £5!

when you subscribe to **Quick Cards** made easy



Dear reader,

Quick Cards Made Easy is the must-read magazine for card makers, offering easy-to-follow step-by-step tutorials and projects, expert advice and quick-make ideas for every budget. Whether you're new to the hobby or looking to expand your skills with more advanced makes, our on-trend designs will excite and inspire you.

The magazine also comes with a fabulous free gift and eight beautiful bonus papers every issue, making it an essential package for anyone with a passion for card making. **Subscribe today and you can try 3 issues for just £5!**

*Hayley*

Hayley Rowe, Editor

## GREAT REASONS TO SUBSCRIBE:

- ✓ First 3 issues for only £5\*
- ✓ FREE gift with every issue
- ✓ Continue with a 25% discount – just £26.95 every 6 issues!
- ✓ Eight unique BONUS papers to craft with every month
- ✓ FREE UK home delivery – never miss an issue
- ✓ OVER 70 new gorgeous card designs featured in each issue

QCHA17

## SUBSCRIPTION ORDER FORM

- Yes, I would like to subscribe to **Quick Cards Made Easy** with the special offer of 3 issues for just £5\* then £26.95 every 6 issues by Direct Debit **SAVING 25%**

### YOUR DETAILS

(it is essential that you complete this section)

Mr/Mrs/Ms/Miss Name \_\_\_\_\_

Address \_\_\_\_\_

Postcode \_\_\_\_\_

Telephone number (in case of queries) \_\_\_\_\_

Email address\* \_\_\_\_\_

**GIFT RECIPIENT'S DETAILS** (please attach a separate sheet with the name, address, email and telephone details of the recipient, if you are giving a gift subscription)

This offer ends 31st December 2017 \*This offer is only available to UK residents paying by Direct Debit and is subject to availability. After your first 3 issues, your subscription will continue at just £26.95 every 6 issues, saving you 25% on the shop price. If you cancel within 2 weeks of receiving your second issue, you will pay no more than £5. Your subscription will start with the next available issue.

Your personal information will be used as set out in our Privacy Policy, which can be viewed at [www.immediate.co.uk/privacy-policy](http://www.immediate.co.uk/privacy-policy)

## PLEASE FILL IN THE DIRECT DEBIT BOX BELOW

INSTRUCTION TO YOUR BANK OR BUILDING SOCIETY TO PAY BY DIRECT DEBIT 

Name and full postal address of your bank or building society:

Name \_\_\_\_\_

Address \_\_\_\_\_

Postcode \_\_\_\_\_

Name(s) of account holder(s) \_\_\_\_\_

Branch sort code \_\_\_\_\_ Bank/building society account no \_\_\_\_\_

### Instruction to your bank/building society

Please pay Immediate Media Company Bristol Ltd Direct Debits from the account detailed in this instruction subject to the safeguards assured by the Direct Debit Guarantee. I understand that this instruction may remain with Immediate Media Company Bristol Ltd and, if so, details will be passed electronically to my bank/building society.

Signature(s) \_\_\_\_\_ Date \_\_\_\_\_

Office use only

Originator's identification no \_\_\_\_\_ Reference no \_\_\_\_\_

8 3 6 8 3 9 \_\_\_\_\_

Banks and building societies may not accept Direct Debit instructions for some types of accounts

## 3 EASY WAYS TO ORDER:

 **ORDER ONLINE** at [www.buysubscriptions.com/QCHA17](http://www.buysubscriptions.com/QCHA17)

 **CALL NOW** on 0844 844 3799 and quote code QCHA17

Lines open weekdays 8am-8pm and Saturday 9am-1pm

 **ORDER BY POST**  
Send this form to **FREEPOST IMMEDIATE MEDIA**  
(please use capital letters)



**Summer lovin'**  
Echo Park Summer Fun 12x12  
Element Shape Stickers, £3.29  
[www.craftie-charlie.co.uk](http://www.craftie-charlie.co.uk)

**Sunkissed**  
Photoplay For the Love of  
Summer 12x12 Element  
Shaped Stickers, £3.29  
[www.craftie-charlie.co.uk](http://www.craftie-charlie.co.uk)



# Favourites Summer stickers

Time to get away with these  
oh-so-colourful summer stickers



**Gone camping**  
Crate Paper Oasis  
Stickers, £4  
[www.hobbycraft.co.uk](http://www.hobbycraft.co.uk)



**Sandy days**  
Little B Sandcastle 3D  
Stickers 9 Pieces, £5  
[www.hobbycraft.co.uk](http://www.hobbycraft.co.uk)



**Floral fun**  
Pebbles Jen Hadfield Simple Life  
Puffy Stickers, £3.47  
[www.craftelier.co.uk](http://www.craftelier.co.uk)



**Tropical treat**  
My Mind's Eye Palm Beach 6x12  
Cardstock Stickers, £1.99  
[www.hey littlemagpie.com](http://www.hey littlemagpie.com)



**Simply summer**  
Simple Stories  
Summer Days 12x12  
Cardstock Stickers,  
£2.99  
[www.hey littlemagpie.com](http://www.hey littlemagpie.com)



**Seaside summer**  
Authentique Seafarer  
12x12 Sticker Details  
Accessories Sheet, £4.39  
[www.craftie-charlie.co.uk](http://www.craftie-charlie.co.uk)

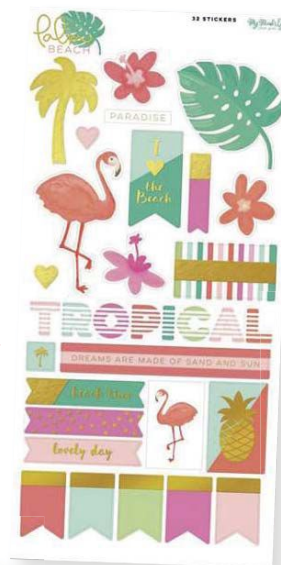

**Palm tree trips**  
Doodlebug Icons  
Cardstock Stickers Fun  
In The Sun, £2.95  
[www.mymumscraftshop.co.uk](http://www.mymumscraftshop.co.uk)





## 1 Butterfly wishes

- 1 Add 40x128mm torn strip of leaf paper to a 123x128mm butterfly paper. Cut around and raise wings of middle butterfly and add panel to a 128mm square of gold mirri card.
- 2 Add panel to a 5x5 base. Make up a small floral envelope; glue one side to a 65x90mm piece of gold mirri. Add butterfly cards inside envelope and one to front. Add sentiment to hold envelope closed.

### Shopping list

Hunkydory Craft Stacks: Butterfly Botanica, £19.99; Hunkydory Crafts: A4 Gold Mirri Card (8 sheets), £5.99; Hunkydory Crafts: 5x5 Ink Me Pre-scored Cards & Envelopes (Pack of 10), £2.99  
**From Hunkydory Crafts**

## 2 For you

- 1 Cover the front of a 5x5 base with gold mirri card. Add 124x20mm, 124x16mm and 124x85mm pieces of patterned paper as shown, and a green foiled border.
- 2 Attach large butterfly topper and sentiment topper with sticky fixers.
- 3 Add a lilac ribbon bow and a vellum butterfly, to finish.

### Shopping list

Hunkydory Craft Stacks: Butterfly Botanica, £19.99; Hunkydory Crafts: A4 Gold Mirri Card (8 sheets), £5.99; Hunkydory Crafts 5x5 Ink Me Pre-scored Cards & Envelopes (Pack of 10), £2.99  
**From Hunkydory Crafts**  
 Lilac ribbon  
**From your local craft shop**



## 5 Wishes

- 1 Cover the front of a 6x6 base card with gold mirri card. Attach 150x27mm and 120x20mm strips of floral paper, 150x10mm and 150x8mm strips of purple foiled paper, and a 150x100mm panel of butterfly paper as shown, first cutting around and raising two of the butterflies' wings.
- 2 Attach tag and sentiment toppers with sticky fixers. Add a grey ribbon bow, to finish.

### Shopping list

Hunkydory Craft Stacks: Butterfly Botanica, £19.99; Hunkydory Crafts: 6x6 Gold Mirri Mats (100 sheets), £11.99; Hunkydory Crafts: 6x6 Ink Me Pre-scored Cards & Envelopes (Pack of 10), £3.50  
**From Hunkydory Crafts**  
 Grey ribbon  
**From your local craft shop**



# Butterfly beauties

Kay Carley uses Hunkydory's new Craft Stacks to make seven gorgeous cards



### 3 Special friend

**1** Attach 28x152mm torn strips of green foiled paper to sides of a 110x152mm piece of purple foiled paper. Add to a 6x6 sheet of gold mirri card and a 6x6 base.

**2** Add trimmed pieces of the 'Birthday Wishes' border as shown. Attach large butterfly topper and sentiment topper with sticky fixers.

#### Shopping list

Hunkydory Craft Stacks: Butterfly Botanica, £19.99; Hunkydory Crafts: 6x6 Gold Mirri Mats (100 sheets), £11.99; Hunkydory Crafts: 6x6 Ink Me Pre-scored Cards & Envelopes (Pack of 10), £3.50

**From Hunkydory Crafts**

### 6 Best wishes

**1** Attach 175x10mm, 175x15mm and 175x35mm torn strips of patterned paper to a 175mm square of butterfly paper as shown. Cut around and raise butterfly wings.

**2** Add panel to a 7x7 panel of gold mirri card and a 7x7 base card.

**3** Slide a butterfly topper under one butterfly's wing and glue firmly into place. Attach sentiment and circular topper with sticky fixers.

#### Shopping list

Hunkydory Craft Stacks: Butterfly Botanica, £19.99; Hunkydory Crafts: 7x7 Gold Mirri Mats (75 sheets), £11.99; Hunkydory Crafts: 7x7 Ink Me Pre-scored Cards & Envelopes (Pack of 10), £3.99

**From Hunkydory Crafts**



### 4 Thank you

**1** Add torn strips of patterned paper to the left-hand edge of a 173x178mm piece butterfly paper as shown. Cut out and raise the wings of the butterflies, then attach to a 7x7 sheet of gold mirri card and a 7x7 base card.

**2** Attach topper panel and sentiment with sticky fixers.

**3** Add vellum butterflies, to finish.

#### Shopping list

Hunkydory Craft Stacks: Butterfly Botanica, £19.99; Hunkydory Crafts: 7x7 Gold Mirri Mats (75 sheets), £11.99; Hunkydory Crafts: 7x7 Ink Me Pre-scored Cards & Envelopes (Pack of 10), £3.50

**From Hunkydory Crafts**

For stockists turn to page 91



### 7 All that is wonderful

**1** Score 254x153mm of gold mirri at 50mm and 100mm; fold to make a stepper card. Add to a 6x6 base.

**2** Add 35mm wide torn strips of leaf paper to the right-hand side of 148x50mm and 148x153mm pieces of butterfly paper; add to base.

**3** Add toppers with sticky fixers, thread with ribbon as shown, and add vellum butterflies, to finish.

#### Shopping list

Hunkydory Craft Stacks: Butterfly Botanica, £19.99; Hunkydory Crafts: A4 Gold Mirri Card (8 sheets), £5.99; Hunkydory Crafts 6x6 Ink Me Pre-scored Cards & Envelopes (Pack of 10), £3.50

**From Hunkydory Crafts**

Cream ribbon

**From your local craft shop**

IN  
THE

# moment

MINDFUL WAYS TO LIVE YOUR LIFE WELL



Photography: Alief Vinicius

BRAND NEW  
MAGAZINE  
CLAIM YOUR  
FREE ISSUE  
TODAY!

*"Enjoy the new monthly magazine that's helping women make the most of every day with mindfulness, creativity and wellbeing. Expect practical creative projects, positive stories and adventures for a healthy body and mind!"*

## wellbeing

Well-informed, fun and inspiring reads to ensure you're immersed in goodness from head-to-toe, through every moment of your day.

## creating

Make and be mindful. Simple, stylish creative projects you will want to show and display, plus gorgeous creative types to read about.

## living

Food trends and recipes for wellbeing and mindfulness, connecting with family, friends (and work), profiles on foodies and home-style experts.

## escaping

Ways to have adventures and challenge the body and soul – spiritual, natural, health & fitness or creative pastimes and alternative retreats.

## CLAIM YOUR FREE ISSUE TODAY!\*

Call 0800 665 426 or text 78070 quoting ITPFCM

\*Your free issue will either be the 1st issue, mailed mid June 2017 or the 2nd issue, mailed mid July 2017. This offer is available to UK residents only for the first 1,000 copies claimed. Limited to one copy per household on a first come, first served basis. OFFER ENDS 31st JULY 2017. Order lines are open 8am-8pm weekdays and 10am-6pm Saturday. Calls are free from all consumer landlines and mobiles. Text entries are charged at the mobile network rate - customers will be contacted by telephone to arrange delivery of the free issue.



## Fridge magnet

**1** Trim a piece of chipboard the same size as the front of your seed packet. **2** Ink the edges of the seed packet with Vintage Photo Distress Ink. Attach to the chipboard. **3** Apply VersaMark ink to the front of the seed packet. Sprinkle with clear ultra thick embossing powder. Heat with a heat tool to melt the powder. Repeat inking and embossing two more times to build up a thick layer of embossing. **4** Attach a magnet to the back.

Finished planting your garden? Don't throw seed packets away, use **Simonne Clay's** ideas to turn them into something fun

## Bird house

**1** Cut out the base and the roof of the birdhouse from Kraft card using the template on page 89. Score and fold along the score lines. **2** Cover the sides and roof with seed packets, as shown. Ink the edges with Vintage Photo Distress Ink. **3** Die-cut a small circle from one of the end panels. **4** Assemble the birdhouse. Apply glue to the top flaps of the side panels and along the diagonal edges of the end panels. Attach the roof to the top of the birdhouse. To finish, add a cream twine bow above the die-cut circle.



*Quick tip*  
Looking for seed packets to match your décor? You can find digital designs by searching online or even stamp your own!



## Pencil pot

**1** Wash and dry a tin can. Trim four seed packets so that you are left with the fronts only. **2** Ink the edges of two seed packet fronts with Vintage Photo ink, and attach to opposite sides of the can. Ensure that the edges of each seed packet are not glued down at this stage, just the centres. **3** Cut the remaining two seed packet fronts in half horizontally. Fold both pieces in half horizontally. Trim triangular banner shapes. Ink the edges with Vintage Photo Distress Ink. Glue the banners to four pieces of cream twine, as shown. **4** Apply glue to the reverse of the banners and attach to the tin can, slipping the ends of the twine underneath the edges of the seed packet fronts. To finish, apply glue to the edges of the seed packets and press down.

# SAVE 60%

when you subscribe to

# Simply Knitting

**Hurry!**  
limited  
offer



Save 60% and get 13 issues for **just £31.49\***



- Step-by-step tutorials and gorgeous, creative patterns for every skill level
- Don't miss an issue of the UK's favourite knitting magazine, PLUS get a free gift every issue!

£5.99  
★ YOU PAY  
★ JUST  
★ **£2.42**  
★ PER ISSUE!

## 2 EASY WAYS TO SUBSCRIBE

 **ORDER ONLINE** at [buysubscriptions.com/SKCCPCP](http://buysubscriptions.com/SKCCPCP)

 **PHONE** Call 0844 322 1251<sup>†</sup> and quote code SKCCPCP

\*Save 60% offer available to UK Direct Debit orders only and is subject to availability. After your first 13 issues, your subscription will continue at just £46.70 every 13 issues thereafter, saving you 40% on the shop price. Offer ends 31 July 2017. <sup>†</sup>Lines open weekdays 8am to 8pm and Saturday 9am to 1pm. UK calls to 0844 numbers will cost 7p per minute plus your telephone company's access charge. Mobile charges may vary. Overseas readers call +44 1795 414 606.

# Prize crossword

Solve the clues then rearrange the letters in the shaded squares to spell the name of a special type of card with a moving tab (9)

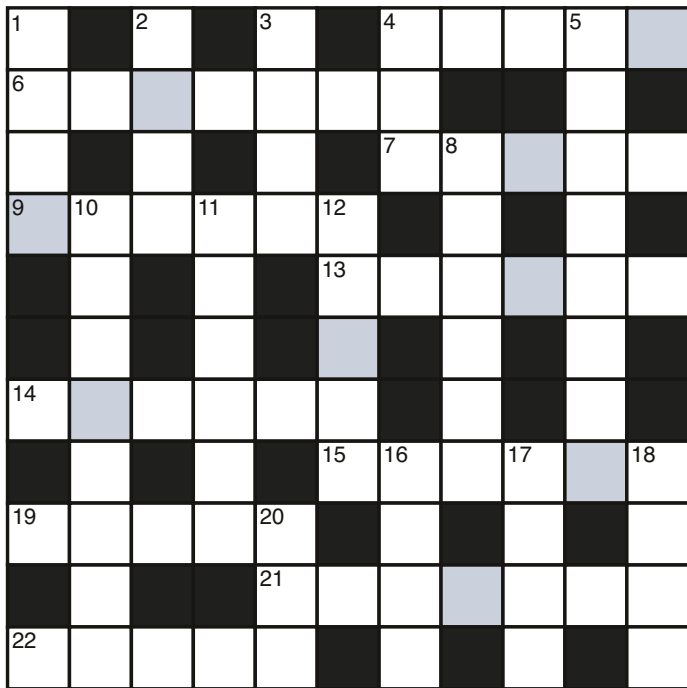

## Across

- 4 Move position (5)
- 6 Football official (7)
- 7 Hooked claw (5)
- 9 Gentle heat (6)
- 13 Long thin cream cake (6)
- 14 Animal with a long body and short legs (6)
- 15 Trying experience (6)
- 19 Polite (5)
- 21 Middling (7)
- 22 Underneath (5)

## Down

- 1 Forehead (4)
- 2 Distant (4)
- 3 Worry (4)
- 4 Solidify (3)
- 5 Group of small boats or ships (8)
- 8 Joined by treaty (6)
- 10 Gluey substance (8)
- 11 Breakfast cereal (6)
- 12 Word of greeting (5)
- 16 Tall grass that grows in marshy land (4)
- 17 Dutch cheese with a red rind (4)
- 18 Onion-like vegetable (4)
- 20 Statute (3)

Four First Edition prizes worth £25 to be won



## First Edition Sweet Nothings paper stack prize bundle worth £25 for four winners!

We've teamed up with Trimcraft this month to give away four fantastic sets of First Edition papers from the new Sweet Nothings collection. Four lucky readers will each win: a 12x12 and an 8x8 paper pad from this charming and romantic collection. Each pad contains 48 sheets of 200gsm patterned paper, with three sheets each of 16 beautiful designs, including fabric, pearlescent and spot UV papers for added texture. The pretty patterns include gorgeous florals, on-trend doilies, rustic woodgrains and endearing sentiments. For more information on the Sweet Nothings range and other First Edition paper collections, visit [www.trimcraft.co.uk](http://www.trimcraft.co.uk).

**HOW TO ENTER:** Send your name, address and answer on a postcard to: **Prize Crossword 171, Cardmaking & Papercraft, Immediate Media Company Bristol Ltd, 2nd Floor, Tower House, Fairfax Street, Bristol BS1 3BN.** The closing date is 20th July 2017. See page 13 for full terms and conditions of entry.

**ISSUE 169 ANSWERS:**  
**Across:** 1 Buttonhole, 6 Cognac, 7 Humbug, 10 Skirt, 13 Ode, 14 Debit, 17 Genius, 20 Advice, 21 Tirelessly.  
**Down:** 1 Brook, 2 Toner, 3 Ouch, 4 Harm, 5 Elegant, 8 Used, 9 Bull, 10 Suggest, 11 Iron, 12 Tofu, 15 Eaves, 16 Itchy, 18 Idle, 19 Safe.  
**Winning answer: BONE FOLDER**

## Win original artwork!

### Purr-maids

Enter our prize draw and you could be the proud owner of this month's original cartoon, drawn by illustrator Ann Edwards. Simply send us your address to be in with a chance!

**HOW TO ENTER:** Send your name and address to us at the address above, marking your postcard **'Cartoon Giveaway 171'**. See page 13 for full T&Cs. The winner is the first name drawn after the closing date of 20th July 2017.

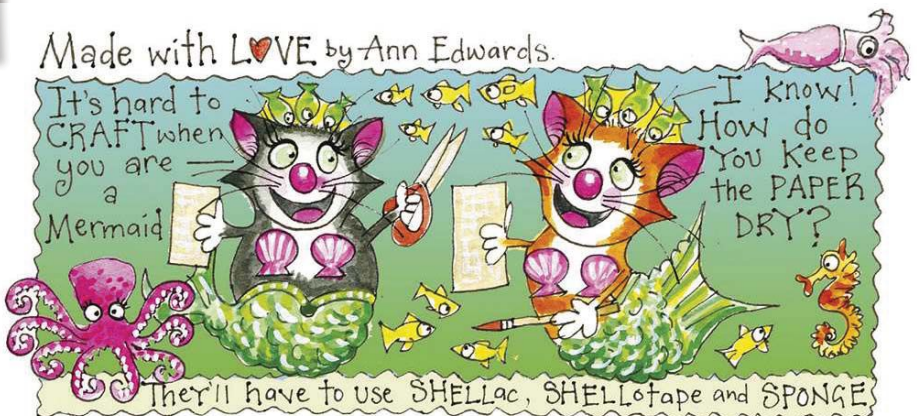

# Templates



Photocopy and cut out these templates, or download and print them from our website, and use to make this issue's projects

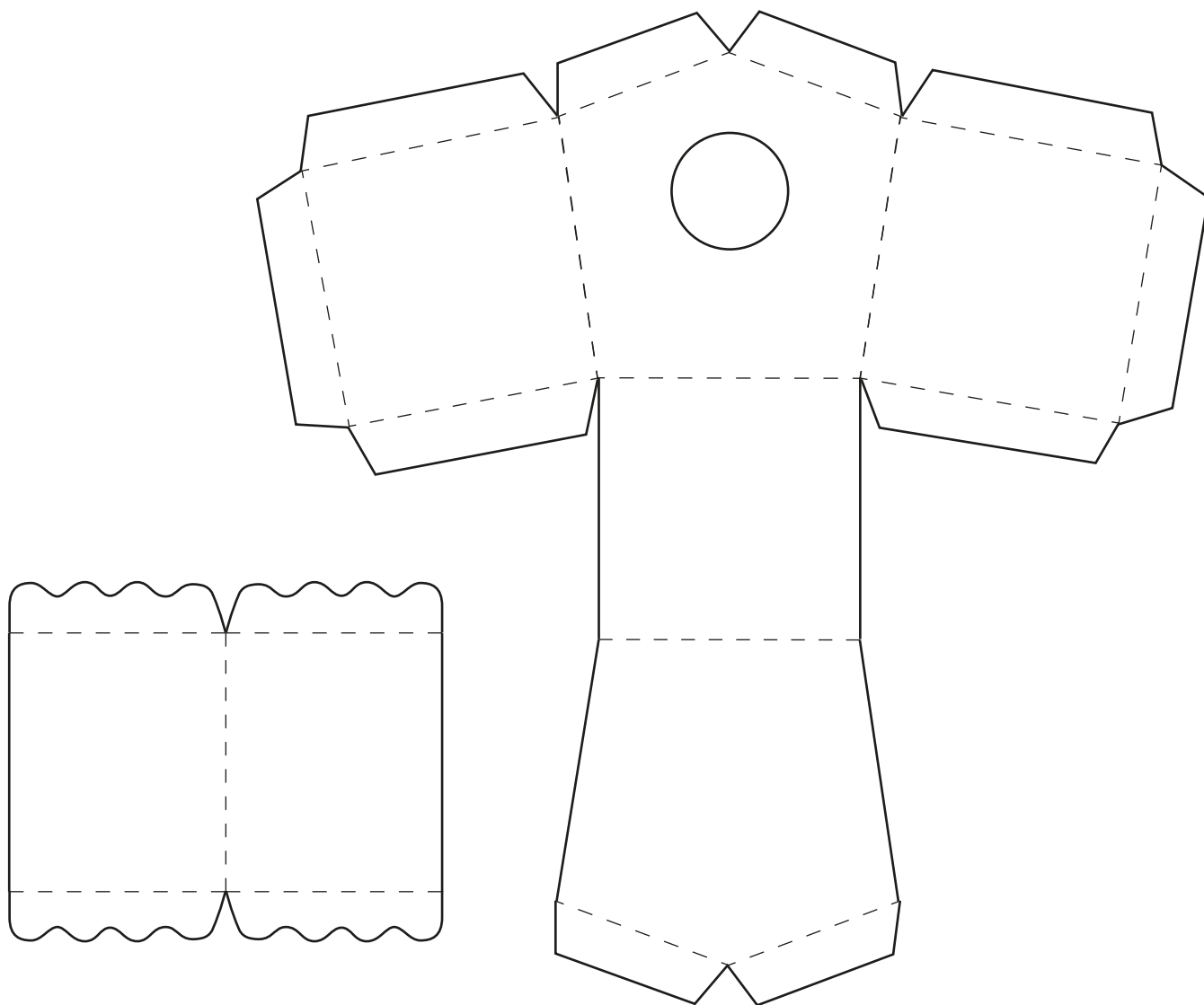

## 10 ideas p58

Trace or photocopy the templates at 200% (double size) to make Sarah Jackman Read's birdhouse box.

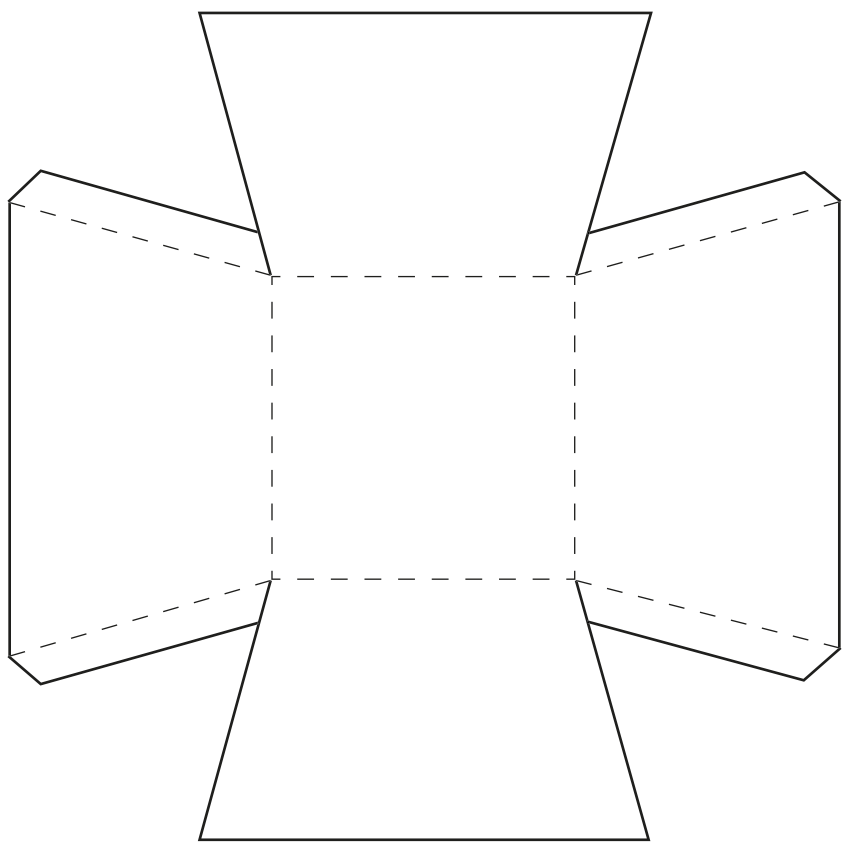
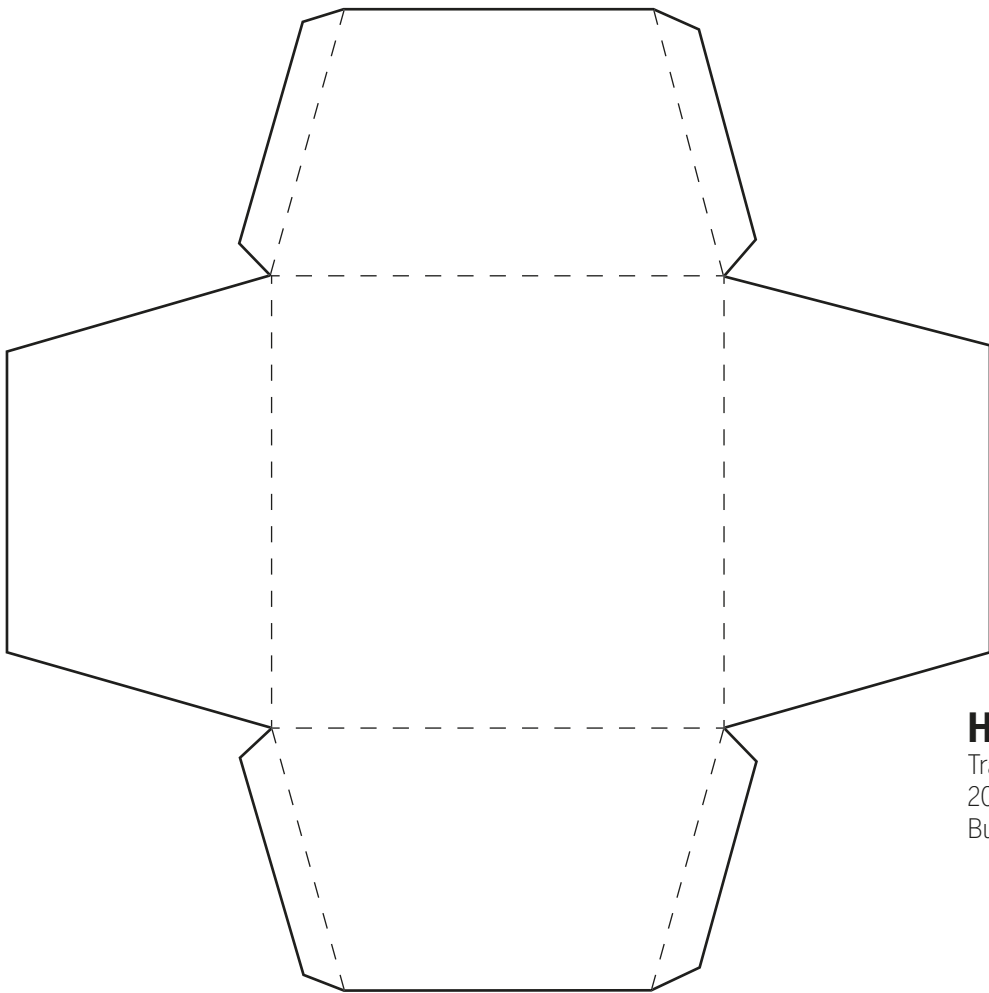

**Home sweet home p46**

Trace or photocopy the templates at 200% (double size) to make Clare Buswell's mortarboard box.



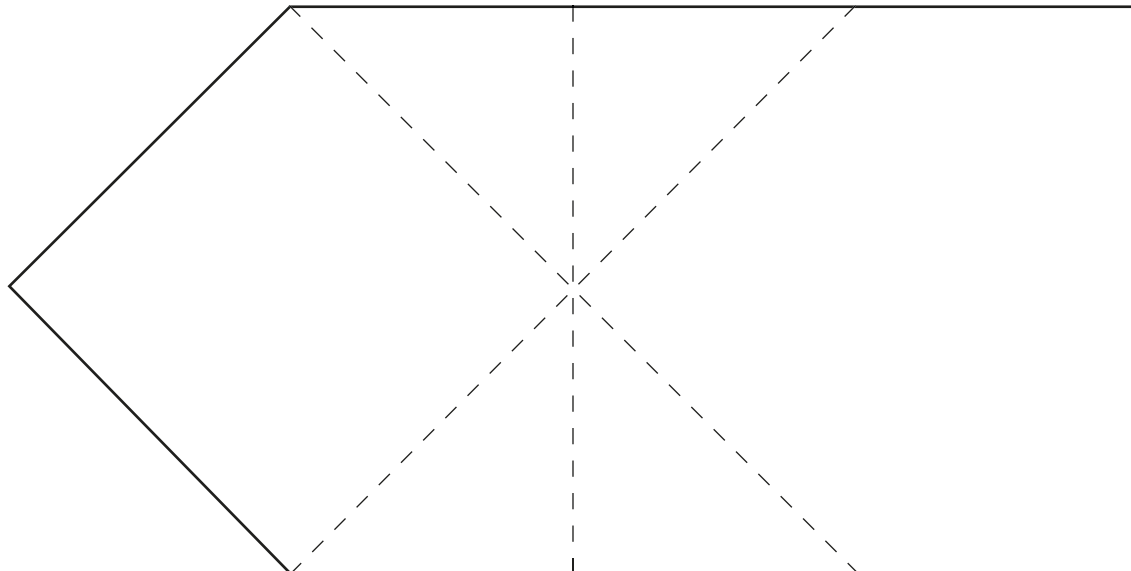

### Home sweet home p46

Trace or photocopy the template above at 200% (double size) and the templates below at 100% to make Clare Buswell's graduation projects.

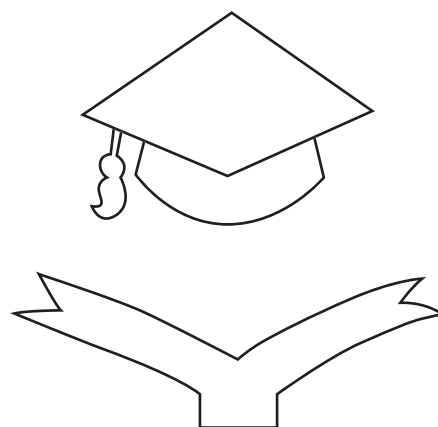
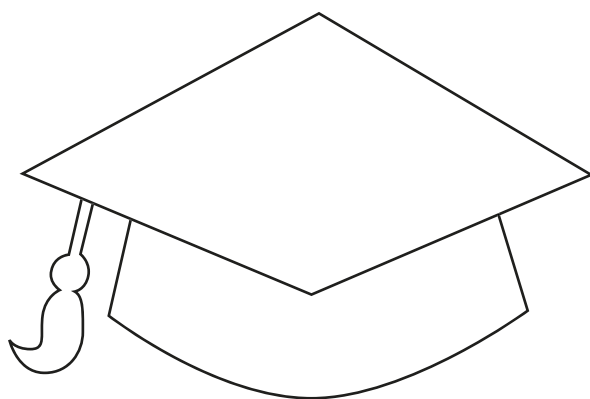

### Upcycle p83

Trace or photocopy the large template at 100% (actual size) and the small template at 200% (double size) to make Simone Clay's birdhouse.

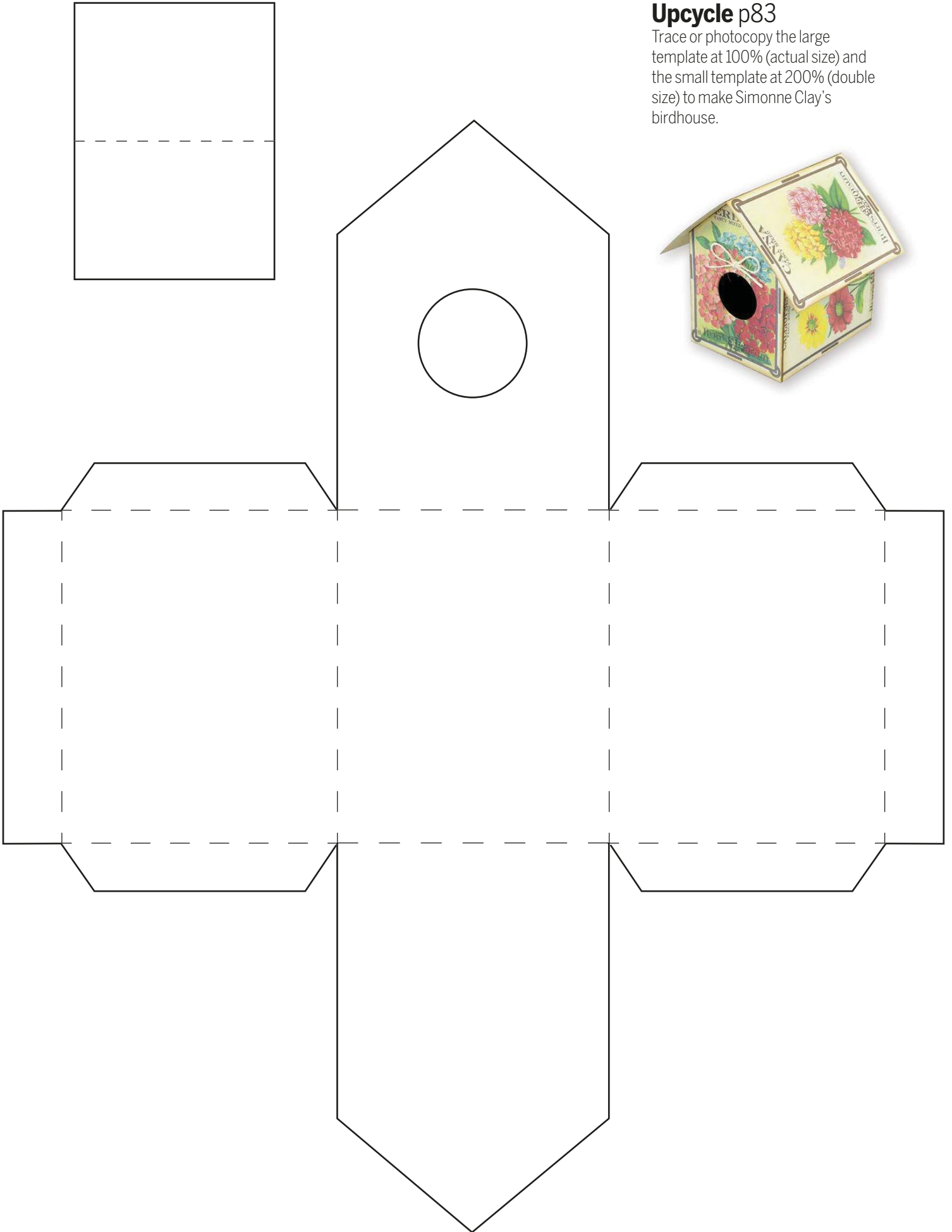

Order  
your copy  
today!

Your gorgeous gardens collection

# Ultimate CrossStitch Gardens

NEW

Only  
£8.99  
inc p&p



Mill house garden

Butterfly gift ideas

French-style sampler

## Ultimate CrossStitch Gardens

Vol 14 2017  
£8.99

255  
charts  
FOR ONLY  
£8.99



Stitched with love



Hydrangea cushion

### DESIGNS YOU'LL LOVE TO STITCH

- \* Botanical cards
- \* Garden gnome gift ideas
- \* ABC sampler
- \* Stylish seed packets
- \* British garden birds and much more



Quick & easy cards



Pretty cottage garden



Playful puppies



The best-loved garden designs – yours to treasure forever!

This beautiful collection has over 255 unmissable designs for garden lovers to stitch and keep – or to give as lovely cards and gifts.

With 255 charts inside, you are sure to find yourself the perfect design to stitch. Choose from a secluded water mill, a cottage garden and picturesque views to frame as pictures. Plus, stitch flowers and butterflies as cards and gifts.

### Inside this issue:

- \* Don't miss Fizzy Moon potting flowers and plants in a must-stitch scene that's full of fun
- \* Make a quick card for a garden-loving friend
- \* Stitch an adorable kitten in a flowerpot – this irresistible card will steal your heart
- \* Stitch perfect garden scenes filled with colour and an abundance of your favourite flowers
- \* Plus, don't forget those welcome garden visitors to the bird table, as well as ladybirds, butterflies – even garden gnomes and playful pixies!



### Your favourite designers

- \* Durene Jones
- \* Joan Elliott
- \* Lucie Heaton
- \* Amanda Gregory
- \* Susan Bates
- \* Lesley Teare
- \* Kate Knight
- \* Maria Diaz
- and more!*

## Order your copy now!

CALL 0844 844 0388 and quote 'ULTGHA17'

ONLINE [www.buysubscriptions.com/craftspecial](http://www.buysubscriptions.com/craftspecial)

Lines open weekdays 8am to 8pm and Saturday 9am to 1pm.

Overseas please call +44 (0) 1795 414 676 EUR price £11.99, ROW price £12.99. All prices include p&p.

# Where to buy

Start your shopping here, with the help of our handy list of all the stockists in this issue of *Cardmaking & Papercraft*

## Amazon

[www.amazon.co.uk](http://www.amazon.co.uk)

## Hunkydory Crafts

[www.hunkydorycrafts.co.uk](http://www.hunkydorycrafts.co.uk)

## Baker Ross

[www.bakerross.co.uk](http://www.bakerross.co.uk)

## Buttercup Crafts

[www.buttercup-crafts.co.uk](http://www.buttercup-crafts.co.uk)

## Charmed Cards & Crafts

[www.charmedcardsandcrafts.co.uk](http://www.charmedcardsandcrafts.co.uk)

## Claritystamp

[www.claritystamp.com](http://www.claritystamp.com)

## Craft Consortium

[www.craftconsortium.com](http://www.craftconsortium.com)

## Craft Creations

[www.craftcreations.com](http://www.craftcreations.com)

## Craft World

[www.craftworldonline.co.uk](http://www.craftworldonline.co.uk)

## Craftasmic

[www.craftasmic.co.uk](http://www.craftasmic.co.uk)

## Crafteezee

[www.crafteezee.co.uk](http://www.crafteezee.co.uk)

## Craftelier

[www.craftelier.co.uk](http://www.craftelier.co.uk)

## Crafter's Companion

[www.crafterscompanion.co.uk](http://www.crafterscompanion.co.uk)

## Craftie-Charlie

[www.craftie-charlie.co.uk](http://www.craftie-charlie.co.uk)

## Crafting.co.uk

[www.crafting.co.uk](http://www.crafting.co.uk)

## Crafts U Love

[www.craftsulove.co.uk](http://www.craftsulove.co.uk)

## Crafty Devils Papercraft

[www.craftydevilspapercraft.co.uk](http://www.craftydevilspapercraft.co.uk)

## Create and Craft

[www.createandcraft.tv](http://www.createandcraft.tv)

## Creative Expressions

[www.creative-expressions.uk.com](http://www.creative-expressions.uk.com)

## Decopatch

[www.decopatch.com/index-en.html](http://www.decopatch.com/index-en.html)

## Daisytrail

[www.shop.daisytrail.co.uk](http://www.shop.daisytrail.co.uk)

## docrafts

[www.docrafts.com](http://www.docrafts.com)

## Easycraftideas

[www.easycraftideas.co.uk](http://www.easycraftideas.co.uk)

## Fox and Star

[www.thefoxandstar.co.uk](http://www.thefoxandstar.co.uk)

## The Fowndry

[www.thefowndry.com](http://www.thefowndry.com)

## Handy Hippo

[www.handyhippo.co.uk](http://www.handyhippo.co.uk)

## Hero Arts

[www.heroarts.com](http://www.heroarts.com)

## Hobbycraft

[www.hobbycraft.co.uk](http://www.hobbycraft.co.uk)

## Hey Little Magpie

[www.heylittlemagpie.com](http://www.heylittlemagpie.com)

## HOCHANDA

[www.hochanda.com](http://www.hochanda.com)

## Hunkydory Crafts

[www.hunkydorycrafts.co.uk](http://www.hunkydorycrafts.co.uk)

## ICHF Events

[www.ichfevents.co.uk](http://www.ichfevents.co.uk)

## IconUK

[www.iconuk.co.uk](http://www.iconuk.co.uk)

## Joanna Sheen

[www.joannasheen.com](http://www.joannasheen.com)

## Lili of the Valley

[www.liliofthevalley.co.uk](http://www.liliofthevalley.co.uk)

## Marianne Design

[www.mariannedesign.nl](http://www.mariannedesign.nl)

## Merly Impressions

[www.merlyimpressions.co.uk](http://www.merlyimpressions.co.uk)

## My Mum's Craft Shop

[www.mymumscraftshop.co.uk](http://www.mymumscraftshop.co.uk)

## Papermaze

[www.papermaze.co.uk](http://www.papermaze.co.uk)

## Personal Impressions

[www.personalimpressions.com](http://www.personalimpressions.com)

## Seven Hills Crafts

[www.sevenhillscrafts.co.uk](http://www.sevenhillscrafts.co.uk)

## Sizzix

[www.sizzix.co.uk](http://www.sizzix.co.uk)

## Stampin' Up!

[www.stampinup.eu](http://www.stampinup.eu)

## StickerKitten

[www.stickerkitten.co.uk](http://www.stickerkitten.co.uk)

## Stone Gift

[www.stonegift.com](http://www.stonegift.com)

## Stuff 4 Crafts

[www.stuff4crafts.com](http://www.stuff4crafts.com)

## Sunrise Crafts

[www.sunrisecrafts.co.uk](http://www.sunrisecrafts.co.uk)

## That's Crafty!

[www.thatscrafty.co.uk](http://www.thatscrafty.co.uk)

## Tonic Studios

[www.tonic-studios.co.uk](http://www.tonic-studios.co.uk)

## Trimcraft

[www.trimcraft.co.uk](http://www.trimcraft.co.uk)

## Wild Rose Studio

[www.wildrocestudio.co.uk](http://www.wildrocestudio.co.uk)

# Back issues & storage

Missed an issue? Complete your *Cardmaking & Papercraft* collection with these back issues and buy a handy slip case to keep them in!



## Issue 170 June

Bring on summer with our inspiration-packed June issue! Create 3D scenes with colourful bendi cards, try our 10 cool ideas with ice cream, make your own working candy machine with die-cuts, master the elegant double embossing technique, marble, embellish and more using nail varnish, celebrate Dad with a fantastic array of Father's Day card ideas, stamp the cutest cat cards, create coffee projects for your home, find pretty ballet ideas, plus get eight summer bonus papers and much more!

**FREE GIFT: Sheena Douglass Create a Flower three-piece die set, worth over £20**



**Issue 164**  
**FREE 2-in-1 Japanese Tea Garden Collection**



**Issue 165**  
**FREE Sincere Sentiments 25-piece stamp set**



**Issue 166**  
**FREE Hunkydory Luxury Card Collection**



**Issue 167**  
**FREE Butterfly die and digi paper set**



**Issue 168**  
**FREE Lace Bouquet 3-in-1 collection**



**Issue 169**  
**FREE For All Seasons stamp & embossing set**

\*Cover gifts available with print edition only

## ORDER NOW

[www.buysubscriptions.com/cardbackissues](http://www.buysubscriptions.com/cardbackissues)

**0844 844 0029**

Lines open weekdays  
8am to 8pm and  
Saturdays 9am to 1pm

## Get organised

Each slip case can hold a year's worth of magazines (13 issues) and ensures your growing collection remains in perfect condition for future reference.

To order slip cases, please visit  
[www.buysubscriptions.com/cardbinder](http://www.buysubscriptions.com/cardbinder)



## BACK ISSUES ORDER FORM (Print edition only)

Your details (please print clearly)

Mr / Mrs / Ms / Miss Name .....

Address .....

Postcode .....

Country .....

Tel number (in case of queries) .....

Email address .....

### Please choose from two easy ways to pay:

I enclose a cheque made payable to Immediate Media Company Bristol Ltd  
(Please write your name and address on the back of the cheque)

Please debit my  Visa  MasterCard  Maestro  Delta

### Card number

Valid from  /  /  Expiry date  /  /  Issue number

Signature ..... Date .....

## Cardmaking & Papercraft

Item	Price	Issue(s)	Qty	Total
Slip case	£7.50			£
Back issues	£6.99			£
<b>Grand total</b>				£

For UK back issues send this coupon (or a copy) to:

**Cardmaking & Papercraft, Back Issues, PO Box 326, Sittingbourne, ME9 8FA**

### Overseas pricing for back issues:

Europe £8.35, Rest of World £9.35. Prices for slip cases are: Europe £9.60, Rest of World £11.50. All prices include P&P. Email [cardmaking@servicehelpline.co.uk](mailto:cardmaking@servicehelpline.co.uk) or send to Overseas Back Issues, Cardmaking & Papercraft, PO Box 326, Sittingbourne ME9 8FA, United Kingdom.

### DATA PROTECTION:

Your personal information will be used as set out in our Privacy Policy, which can be viewed at [immediate.co.uk/privacy-policy](http://immediate.co.uk/privacy-policy). Please give us your email address to receive special offers and promotions from Immediate Media/Cardmaking & Papercraft. You may unsubscribe at any time.

# Glossary

From die-cutting to découpage – if you're new to the cardmaking world you might be wondering what it all means...

**Aperture** An aperture is a shaped hole cut from the front of a base card.

**Bone folder** A tool used to make a neat, sharp crease in paper or card.

**Découpage** There are two very different découpage techniques. The first is the art of creating a 3D image from paper layers. The smaller parts of a repeated image are cut out and layered on top of the original image with sticky fixers. The second is when pieces of découpage paper are used to cover an object, usually using watered-down PVA glue or Mod Podge.

**Die-cutting** A die-cutting machine cuts out shapes from paper or card. The machine sandwiches metal dies (templates) over your chosen card, which is then fed through a roller by turning a handle on the machine.

**Distressing** A technique where card or paper is distressed with a tool to create a rough-edged, aged finish.

**Embossing** This technique adds a raised image, pattern or greeting. It is often done by hand using a stencil or board with an embossing tool.

**Embossing folder** This plastic folder has a raised design on one side and an indented design on the other. Place card inside the folder and run through a die-cutting machine using the correct plates to emboss.

**Embossing paste** This is a thick paste that can be applied to cards to create a raised, embossed image, usually used with a stencil.

**Faux stitching** This involves using a fineline pen to imitate stitches by drawing lines.

**Fussy cutting** In papercraft, this means using scissors to cut out an image or motif from patterned paper.

## Conversion chart

5mm	¼ inch	150mm	6 inches
10mm	½ inch	170mm	6½ inches
20mm	¾ inch	180mm	7 inches
25mm	1 inch	200mm	8 inches
30mm	1¼ inches	230mm	9 inches
40mm	1½ inches	240mm	9½ inches
50mm	2 inches	250mm	10 inches
75mm	3 inches	280mm	11 inches
100mm	4 inches	300mm	12 inches
120mm	4½ inches	320mm	12½ inches

**Glossy Accents** A clear, three-dimensional gloss made by Ranger. Use it to accent and protect distinct areas of your projects.

**Heat embossing** This technique creates a shiny, raised effect on a stamped image. Stamp using a slow-drying ink such as VersaMark, sprinkle over with embossing powder and tap off the excess before gently heating with a heat tool.

**Kraft card** This is light brown, usually recycled, card that is used for layering with backing papers.

**Masking** This involves covering an area of card before stamping or colouring so that the colour or image underneath is unaffected.

**Mod Podge** A brand of water-based glue. Use for découpage projects, or as a general adhesive.

**Parchment craft** The art of embossing and piercing specialist paper to create an image or pattern.

**Punches** These are used to punch out shapes to decorate cards. There is a huge variety available, including border punches and nesting punches.

**Shaker card** A shaker card is a type of card that has a clear window which is filled with various beads and/or glitter. The card can then be shaken to see the embellishments move.

**Sticky fixers** These are tiny, sticky foam pads used to give a 3D effect when attaching panels to a base card, or between layers of découpage.

**VersaMark ink** A thick, clear ink that dries slowly, which is used in stamping and heat embossing.

**Washi tape** This is a kind of decorative masking tape with the properties of rice paper.

## Cardmaking & Papercraft

This issue is brought to you by...



**Editor**  
Sienna Parulis-Cook  
sienna.parulis-cook  
@immediate.co.uk



**Deputy Editor**  
Jo Stenlake



**Editorial Assistant**  
Molly Price



**Art Editor**  
Robert Bewick



**Designer**  
Matilda Smith

**Photography** Gavin Roberts, Steven Sayers, Ally Stuart

**Designers** Clare Buswell, Sharon Callis, Kay Carley, Simonne Clay, Hazel France, Tracey Grundy, Ruth Hamilton, Paula Holfield, Sue Hughes, Sarah Jackman Read, Carolyne Knott, Jo Nevill, Fleur Pearson, Lisa Plummer, Sarah-Jane Rae, Anne Richardson, Dorothy Wood

**Contributors** Michelle Anders, Ann Edwards, Deb Ellis, Barbara Gray, John Lockwood, Carol McCormick, Leonie Pujol, Maria Simms  
**Group Advertising Sales Manager**  
Penny Stokes, Tel 0117 300 8206  
penny.stokes@immediate.co.uk

**Advertising Sales Manager**  
Anna Summerson, Tel 0117 300 8227  
anna.summerson@immediate.co.uk

**Ad Services Manager** Paul Thornton  
**Ad Coordinator** Jade O'Halloran

**Ad Designer** Alice Davenport  
**Production Director** Sarah Powell  
**Production Coordinator** Lizzie Ayre

**Reprographics** Tony Hunt, Chris Sutcliffe  
**Subscriptions Director**  
Jacky Perales-Morris

**Direct Marketing Manager** Penny Clapp  
**Direct Marketing Executive** Joe Jones  
**Director of Licensing & Syndication**  
Tim Hudson

**Buying Team** Paul Torre, Corinne Mellerup, Karen Flannigan

**Publisher** Catherine Potter  
**Creative Development Publisher**  
Anna Davenport

**Group Managing Director** Andy Marshall  
**CEO** Tom Bureau

**Distribution** Frontline Tel 01733 555161  
**Printed in England** by William Gibbons



Cardmaking & Papercraft is published by

**IMMEDIATE MEDIA**<sup>CO</sup>

Cardmaking & Papercraft, Immediate Media Company Bristol Limited, 2nd Floor, Tower House, Fairfax Street, Bristol BS1 3BN  
Tel: 0117 927 9009 Fax: 0117 934 9008

Immediate Media Company Bristol Limited is dedicated to producing the very best consumer specialist interest magazines, edited and designed to inform our readers, enhance their lives and give them the best value for money possible. Please visit [www.immediate.co.uk](http://www.immediate.co.uk) for details of our other publications. We take great care to ensure all elements of Cardmaking & Papercraft are accurate. However, we accept no liability for any misprints or mistakes that appear in this magazine. All prices quoted are correct at the time of going to print. © Immediate Media Company Bristol Limited

**Copyright** You may make cards from this issue of Cardmaking & Papercraft and sell your cards (unless otherwise stated) as long as you do not go into mass production

### Want to stock the magazine?

Call Worldwide Magazine Distribution on 0121 788 3112 or visit [www.wmmd.co.uk](http://www.wmmd.co.uk)

**To subscribe** call the hotline 0844 844 0029 or email [cardmakingandpapercraft@servicehelpline.co.uk](mailto:cardmakingandpapercraft@servicehelpline.co.uk)  
USA & Canadian subscription hotline  
Toll-Free 866-926-0269 or email  
CAFcustserv@cdsfulfillment.com  
BAR rates: UK £48.50 annually,  
EUR £60 annually, ROW £72 annually

We abide by IPSCO's rules and regulations. To give feedback about our magazines, please visit [www.immediate.co.uk](http://www.immediate.co.uk), email [editorialcomplaints@immediate.co.uk](mailto:editorialcomplaints@immediate.co.uk) or write to Sienna Parulis-Cook, Immediate Media Co., Tower House, Fairfax Street, Bristol BS1 3BN



Immediate Media Company Bristol Limited is working to ensure that all of its paper is sourced from well-managed forests.

This magazine can be recycled, for use in newspapers and packaging. Please remove any gifts, samples or wrapping and dispose of it at your local collection point.



**37,064**  
1st Jan to 31st Dec 2013  
A member of the Audit Bureau of Circulations



Send your letters to **Dear Sienna**, Cardmaking & Papercraft, 2nd Floor, Tower House, Fairfax Street, Bristol BS1 3BN, or you can email the team at [writetous@cardmakingandpapercraft.com](mailto:writetous@cardmakingandpapercraft.com)

# Toolbox

Your indispensable guide to the craft essentials every cardmaker should own...

## 1 Back to basics

You'll need most of these items in addition to those listed on our shopping lists for every project you do...

### White card

Use to stamp on and to make base cards

### Black ink

Use to stamp sentiments and images

### Trimmer, craft knife, craft mat, scissors

Use for basic cutting and trimming

### Base cards

Available in a variety of sizes and colours – buy ready-made or make your own

### Bone folder

Use to achieve a sharp crease when folding base cards

### Glues

Adhesive dots, sticky fixers, glue sticks, double-sided tape and silicone glue are most commonly used

## 2 Tools of the trade

Some cardmaking techniques require special tools; these are the most common...

### Heat tool

For heat embossing: use with clear pigment ink such as VersaMark ink and embossing powder for a glossy, raised effect on stamped images

### Die-cutting machine

There are traditional, electronic and digital models available. They use dies to cut out shapes from a variety of materials

### Eyelet setter

Use to add decorative eyelets to your designs

### Stencils

Use with an embossing tool, chalks or inks

### Embossing tool

Use with stencils or embossing boards to create a raised effect

### Punches

These allow you to easily punch out small shapes and fancy borders

## 3 The fun stuff

Once you've got the basics sorted, you're ready to get creative...

### Stamps, inks and embossing powders

Use stamps to create perfect images, and add texture with heat embossing

### Pencils, marker pens, chalks and watercolours

Use to add colour to motifs, card panels and stamped images

### Ribbons

Use these to add texture, colour and little bows

### Stickers and rub-ons

These are a popular, easy way to decorate and add sentiments

### Embellishments

These include brads, gems, fabric flowers, beads and more...

### Patterned papers

Use patterned papers to add layers, colour and texture to your designs

BRAND NEW  
PRODUCT RANGE

# 3D

## EMBOSSING FOLDERS

BROUGHT TO YOU BY

*Crafter's Companion*



# NOW AVAILABLE

CREATE FANTASTIC  
MULTI-DIMENSIONAL  
EMBOSSSED EFFECTS!

AVAILABLE FROM YOUR LOCAL STOCKIST OR FROM [WWW.CRAFTERSCOMPANION.CO.UK](http://WWW.CRAFTERSCOMPANION.CO.UK)

August  
issue on sale  
6th July

Next month in

# Cardmaking & Papercraft

FLOWER  
FAIRIES™

## Fairies of Summer

cardmaking collection

Your free gift includes:

- 🌸 4x foiled & die-cut topper sheets
- 🌸 10x coordinating papers



**YOUR  
FREE  
GIFT!**

*Plus*  
Six ideas to  
make with  
your free gift\*

Cardmaking

© The Estate of Cicely Mary Barker, 1925, 1990  
Reproduced by permission of Frederick Warne & Co.  
www.flowerfairies.com



Worth  
£7.99



Make all this & more...



# Mirror, mirror

Make **fairytale cards** with mirror stamping

**4 SUMMER**  
bonus papers

# Quick makes

Beautiful card ideas for **all occasions**



# True blue

Create your own **handmade paper**



# Go fish!

Craft this amazing **paper aquarium**

# Wedding season

Say 'I do' to these 10 craft ideas



Contents subject to change

**To subscribe today**  
**call 0844 844 0029**

\*\*UK print subscription only. Terms & conditions apply, see page 32

Get a  
Chameleon  
Color Tones  
Pencil set when  
you subscribe\*\*



# The last word with...

## Leonie Pujol

The craft TV star and mag columnist recalls how she transformed from shy student to professional presenter



**D**escribe your home – is there a lot of handcrafted décor? I'm actually in the process of moving house, so my home is currently full of boxes! Amongst those boxes there isn't really a lot of handcrafted décor, but I do love buying art, so I do have a few lovely prints, and I also collect handmade mugs. I love pottery, and I enjoy buying a handcrafted mug when I visit somewhere new.

What has been the biggest surprise since you started designing your own line of craft products? How time consuming it is! From the initial idea, to getting the physical product takes months – and there's an awful lot of work involved. I'm so pleased I have the experience of the Crafter's Companion team, that really does help. It's good to bounce ideas off other people as well – as it may sound great in my head, but that doesn't mean it will be great in real life! It's also a very competitive market – trying to come up with an idea that's going to appeal to others can be difficult, and is really scary. You never know if something you have designed will be popular, or even understood, as sometimes the vision you have for a product may not be immediately obvious!

How do you keep from getting too messy when doing mixed media? Haha... I don't! I don't mind getting messy, in fact I enjoy the process. It all washes off – eventually. Or sands off (thinking about my dining table). Or washes out (thinking about all the clothes covered in paint!).

Is there one particular artist or school of art that inspires you the most? Wow, there are so many artists I love, and it's a very eclectic mix of styles as well. I love architecture, from Gaudi to gothic haunts. I also adore sculpture, ceramics, graffiti... the list goes on. I think my love of many different styles comes across in my crafting, as I always love to find new products to experiment with.

Did you ever imagine as a child that you would be a celebrity crafter? Good grief no. I was so shy at school, which generally comes as a shock! I definitely never saw myself on TV, and never had any ambition to go in that direction. I used to do craft fairs with my sister, and realised I didn't want a "proper" job (I worked in a stockbrokers in Manchester), but wanted to follow what made me happy, which

*"I realised I didn't want a 'proper' job, but wanted to follow what made me happy"*

was making things. It was a risk, but most definitely worth it! I think I must have been about 26ish. Gosh, that's a while ago! I still don't see myself as a celebrity crafter – that just makes me giggle!

How did you first get on television? I used to work for Dawn Bibby, helping behind the scenes for her weekly show on QVC. Dawn always used to try and convince me to try guesting, but I used to go bright red and giggle at the



Leonie with her three lovely dogs

thought of it. Dawn's mum was very poorly one week, and Dawn couldn't do her show, so I stood in! I was so scared, but got the bug. Dawn really encouraged me, and gave me lots of help to develop. It was great fun, and I really grew to love it!

What would we find you doing on your days off? Well, of late, packing boxes! When I'm not moving house, I always spend time with my dogs, making sure they get their walks, which I love. I try to see my friends and family and spend time going out and having a laugh. I have also been doing more workshops and demonstrations, so some days off will be spent prepping. I love visiting new towns, and having a nosey 'round (I'm vegan, so obsessed with trying to find places which offer good food!). Of course, there is always prep for my "Let Leonie Loose" show as well. Crafting generally occurs on a day off.

What three adjectives best describe your crafting style? Experimental; eclectic; impulsive.

Watch "Let Leonie Loose" every week on HOCHANDA; shop her range of crafting products at [www.crafterscompanion.co.uk](http://www.crafterscompanion.co.uk); and read her monthly column in *Cardmaking & Papercraft!*



Leonie loves playing with different styles and techniques



# Hunkydory

● CRAFTS ● LIMITED ●

YOUR ONE STOP WEBSITE FOR PAPER-CRAFTS!

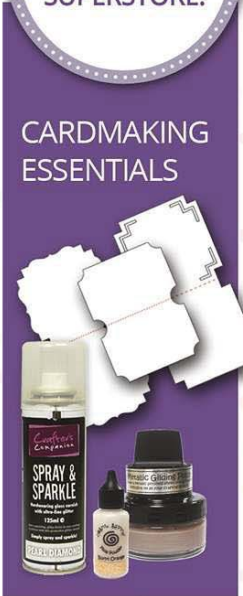

Visit: [www.hunkydorycrafts.co.uk](http://www.hunkydorycrafts.co.uk)

Connect with us



## Craft Creations

New Die-Cut Découpage Designs

[www.craftcreations.com](http://www.craftcreations.com)

[www.e-crafts.co.uk](http://www.e-crafts.co.uk)

Suppliers of Cardmaking, Scrapbooking, Craft & Bridal Supplies

General Craft Supplies ✿ Floral Products  
✿ Card Embellishments ✿ Bridal Supplies  
✿ Baby Embellishments ✿ Card & Paper Supplies  
✿ Seasonal Items ✿ Special Offers

Cardmaking and Scrapbooking Supplies

Units B4/B5, Dudley Central Trading Estate, Shaw Road, Dudley, West Midlands DY2 8TP

Phone: 01384 230000 Mobile: 07751 891754  
Fax: 01384 235666 Email: [sales@e-crafts.co.uk](mailto:sales@e-crafts.co.uk)

Internet & Mail order only

## INSPIRATIONAL PAPER-CRAFT SHOW

... the hands on show for papercrafters, stampers and cardmakers

### NEWBURY PAPER-CRAFT SHOW

At Berkshire stand, NEWBURY RACECOURSE, Newbury, Berks. RG14 7PN

(entrance over new bridge from Hambridge Road- directions available from website)

On Saturday 8th July 2017

Open from 10:30 – 4:00pm

Admission £3.00, Under 16s FREE

Workshops, Make n Takes, and Demonstrations running all day

*Celebrity crafters include*

*John Lockwood, Jenny Mayes, Kay Carley, Jane Gill, Michelle Johnson etc*

Refreshments available all day

[Facebook.com/NEWBURY PAPER-CRAFT SHOW](https://www.facebook.com/NEWBURY-PAPER-CRAFT-SHOW)

Organiser Wendy Kadzidlo on 01488 658728

Directions can be downloaded from [www.stampsandmemories.co.uk/blog/newbury-paper-craft-show/](http://www.stampsandmemories.co.uk/blog/newbury-paper-craft-show/)

# BUDDLY Crafts

THE  
ONLINE  
SHOP  
FOR  
CARDMAKERS &  
MIXED MEDIA  
ARTISTS



NEW CUTTING DIES & CRAFT PRODUCTS EVERY MONTH

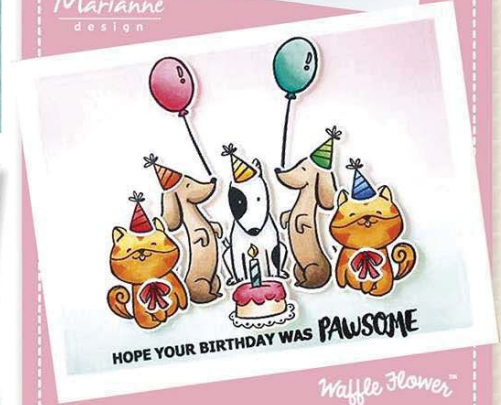

**BuddlyCrafts.com**

FREE UK SHIPPING  
ON ORDERS OVER £30

**DUTCH DOOBADOO**  
New Masks & Card Art  
Templates every month



**Waffle Flower™** Stamps & Dies

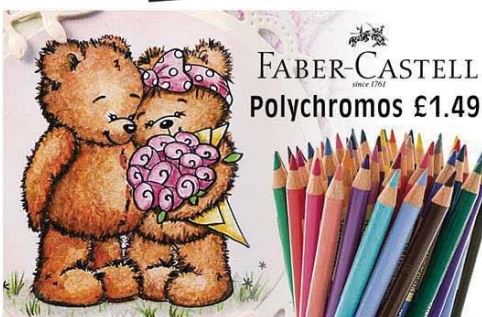

**Beat the Clock & SAVE 5%** on 1st week listings of all new products.



Products available whilst stocks last.  
Prices correct at time of going to press.