

SACRED THEMES

SWANS
IN THE SWIM

MAGIC CROCHET

**FILET,
PATCHWORK,
AND FINE-ART
TABLECLOTHS**

BEAUTIFY YOUR TABLE



FEBRUARY 1992 - Number 76 - \$ 3.25 - Canada - \$ 3.75

Dear Reader,

Tell me what you eat and I will tell you who you are, as the old saying goes. But the way you set the table also reveals your personality – to your guests! The most elegant table decor often features a tablecloth covered with a topper. And our topper patterns are filet, fine-art or patchwork projects. One of the many festive tables in this issue of MAGIC CROCHET is bound to be exactly the “tablewear” statement you want to make.

After the party is over and your house is back to normal, you may find a different use for your beautiful topper. Give it a place of honor on your cherished antique, where the fine lace and soft color will add a perfect extra touch to a home-sweet-home atmosphere.

In fact, all this coziness will probably inspire you to start on a new project right away. And we suggest you turn quickly to page 24 of this issue of MAGIC CROCHET for a special bonus. There you will find detailed instructions on how to finish, press and starch your crochet creations for best results.

Here is wishing you happy crocheting and much enjoyment.

Sincerely yours,

Paulette ROUSSET



LES EDITIONS DE SAXE

20, rue Croix-Barret
69358 LYON CEDEX 7 (France)

Director in charge : Guy ROUSSET

Editor : Paulette ROUSSET

Page-setting : Eric GUERIN

MAGIC CROCHET (ISSN 0246-5957)

published bi-monthly

by LES EDITIONS DE SAXE S.A.

69358 LYON CEDEX 7 FRANCE

Rate : \$ 3.25 per copy; \$ 16.25

per year in the U.S. and territories.

Second class postage paid

at Patterson, N.Y. 12563 and

at additional mailing offices

Issue N° 76 - February 1992

© 1992 LES EDITIONS DE SAXE S.A.

All rights reserved. Reproduction in any manner in whole or in part, except as authorized by the Copyright Act, is prohibited.

POSTMASTER : send address changes

to MAGIC CROCHET,

Subscription Dept.

PO BOX 5830

PATTERSON, N.Y. 12563

in CANADA, send address changes

to MAGIC CROCHET

Subscription Dept.

279 Humberline Drive

Rexdale, Ontario, M9W 6L1

Printed in U.S.A.

Canadian goods and services

tax registration number R124617572

- 7 How to follow the diagrams
- 8-9 Crochet basics
- 24 Finishing, pressing, starching



SWEET NOSTALGIA

- 4-5 Open secret
- 6 Leaf lace
- 10-11 Alone
- 12-13 Swans together

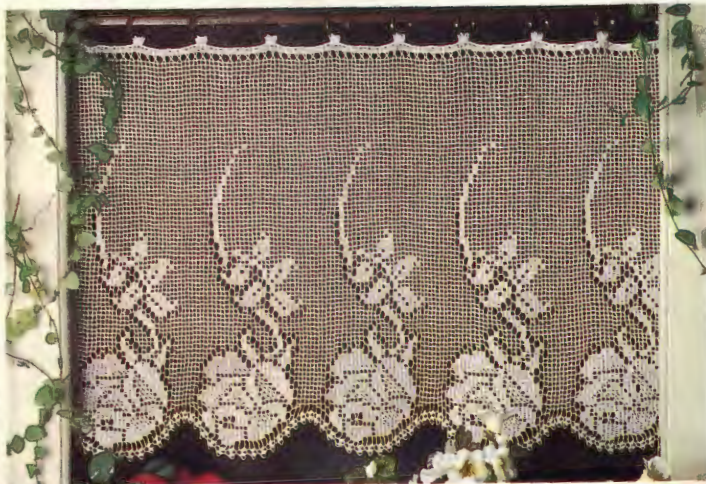

FESTIVE TABLES

- 14-15 Solstice
- 16-17 Mixed floral
- 18-19 Mosaic
- 20-21 Symphony
- 22-23 Checkers
- 24-25 Breeze
- 26-27 Knitter's special
- 28-29 Applause
- 30-31 Ambiance
- 32-33 Ardor

CROCHET CHARM

- 34-35 Mutliwhirl
- 36-37 Floret lace
- 38-39 Napkin keeper
- 40-41 Green and gold
- 42-43 Venus in view
- 44-45 Great moment
- 46-47 White lotus
- 48-49 Proper poposal
- 50 Artistic book mark

AT-HOME IDEAS

- 52-55 Filmstrip
of how-tos
Raindrops in
the water
- 56-57 Easy living
- 58-59 Regency



TIME OFF

- 60-61 Vineyard memento
- 62-63 Sweet scents
- 64-65 Good read
- 66-67 Grape festival
- 68-69 Wild goose

DISTINCTIVE TOPPERS

- 70-71 Medallion
- 72-73 Majesty

LEARN A STITCH

- 74-75 Row by row:
a Magic selection
- 76-77 Puff stitches
- 51 Back issues

CROCHET WORKSHOP

- 78-82 Popcorn pullover
- 83 Coming in the
next issue



1

OPEN SECRET

By *Kyoko Takagi*

SIZE:
Width: 29 3/4 inches, including edging 1/8" deep on each side.
Length: 18 1/2 inches.

MATERIALS:
Crochet cotton with sheen (or fil d'Ecosse) no. 20, white, about 890 yds. Steel crochet hook US size 11 or **SIZE FOR GAUGE**. 10 plastic rings 1 3/8" in diameter measured on outside.

GAUGE:
4" square = 19 meshes and 20 rows. If you use pearl crochet cotton no. 5 and steel crochet hook US size 7, you will obtain curtain measuring about 27 1/2 by 37 1/2 inches.

TO MAKE CURTAIN: Beg at one side edge, ch 248. **ROW 1:** 7 ch, 3-dc cl (see how-to) in 8th st from hook, 5 ch, 3-dc cl in next st, 5 ch, sk 5 sts, 3-dc cl in next st, work * 2 ch, sk 2 sts, dc in next st, rep from * 76 more times (= 77 open meshes <om> in all), 5 ch, sk 5 sts, dc in each of 4 last sts; ch 3, turn. **ROW 2:** Dc in each of next 3 dc, 2 ch, sc in ch-5 lp, 2 ch, dc in next dc, 77 om, 5 ch, dc + 5 ch + dc in ch

lp located bet 2 cls; ch 7, turn. **ROWS 3-150:** On row 3, beg with 3-dc cl + 5 ch + 3-dc cl in first ch lp, 5 ch, dc in 4th st of next ch lp, then cont working back and forth as per pat diagram and 2-dc cl how-to. At end of row 150, fasten off. **EDGING:** RS facing, attach thread with sl st in first dc of row 150 and work 1 row sc across side edge, top edge and opposite side edge of curtain; fasten off. **HANGING LOOPS:** For each loop, work 5 rows dc as shown. Insert ring in each loop, fold in half to WS and sew in place with overhand stitches.

1/8" 29 1/2" (150 rows)

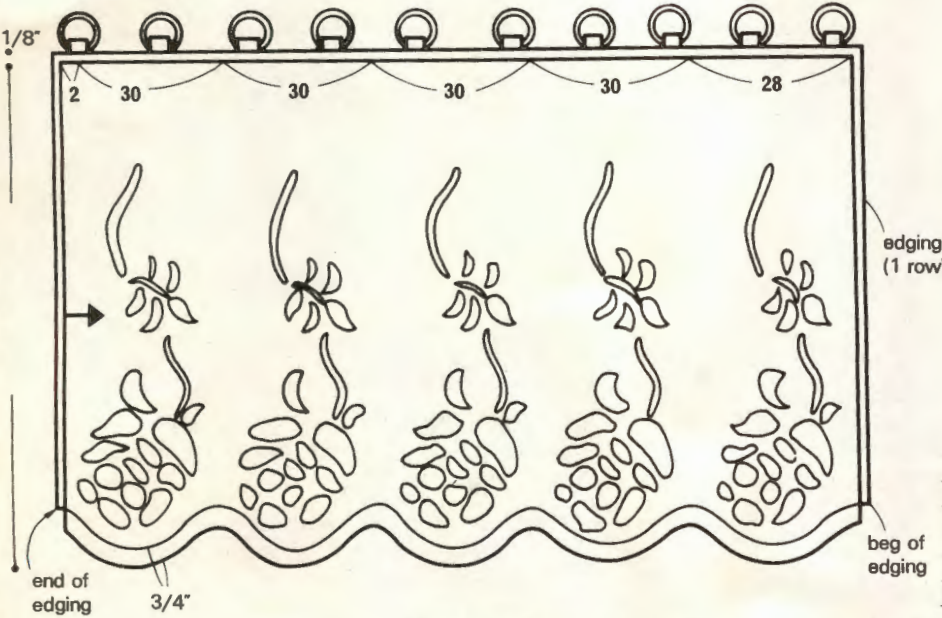

GAUGE: 4" square = 19 meshes x 20 rows

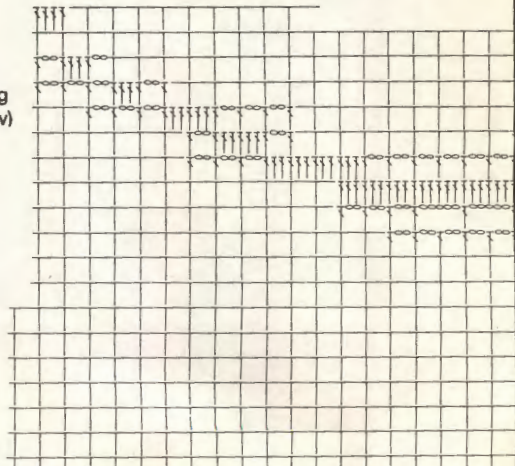

sew to WS of edging

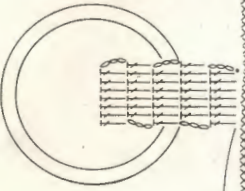

sk 14 rows

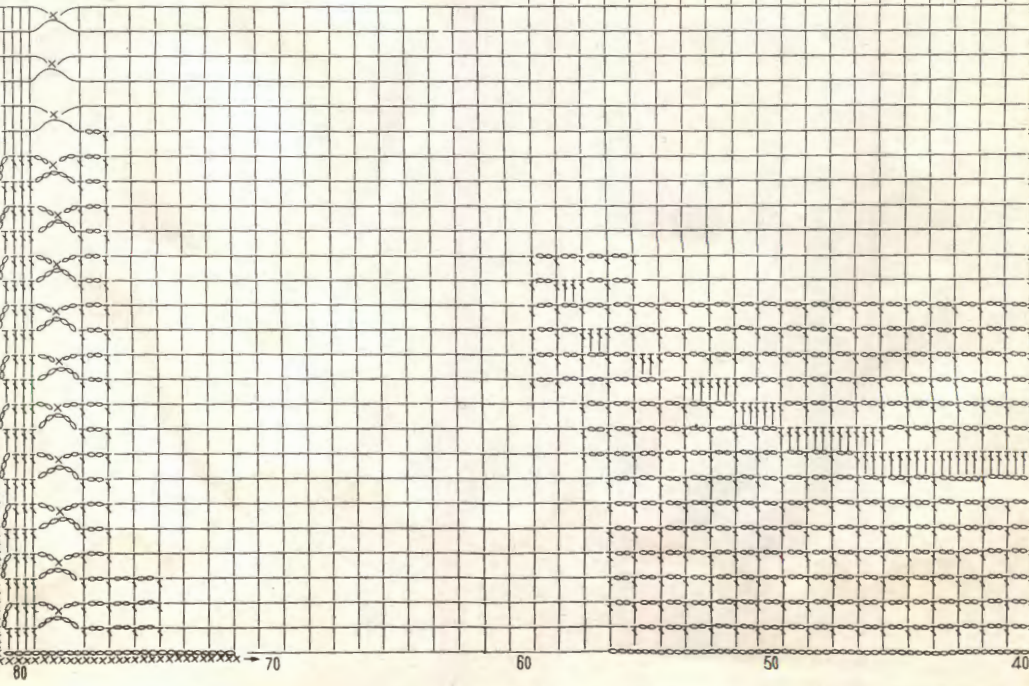
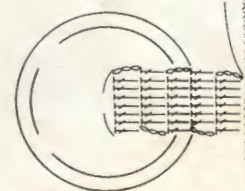

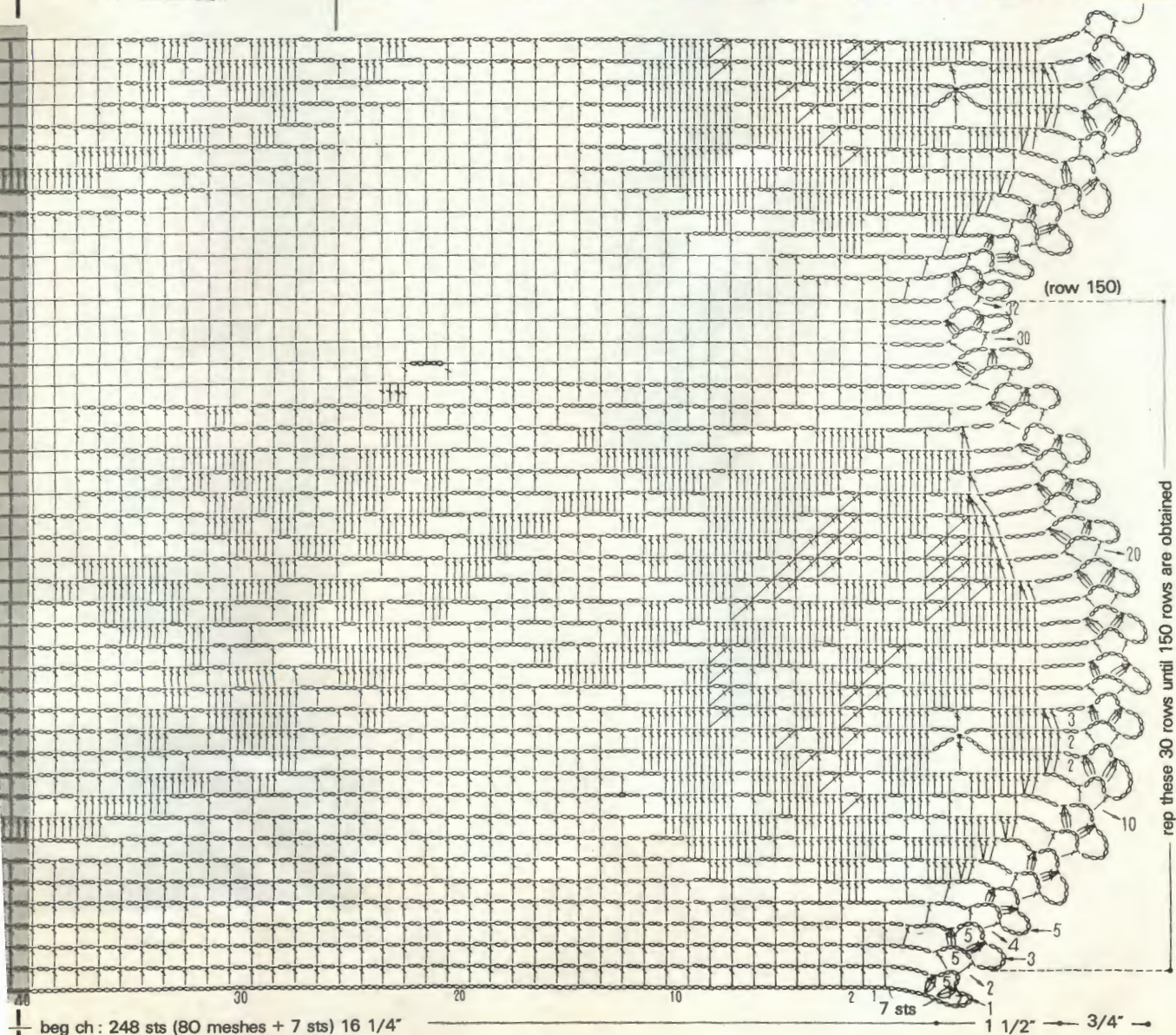
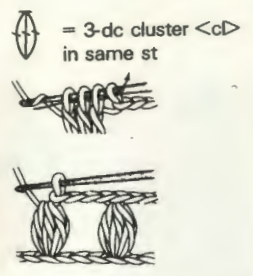
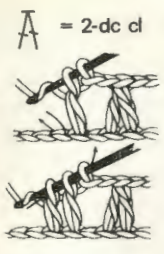

rep these 30 rows until 150 rows are obtained

beg ch : 248 sts (80 meshes + 7 sts) 16 1/4"

1 1/2" 3/4"

2 LEAF LACE

By Chantal Chevallier

SIZE:
3 1/2" wide, 79" long.

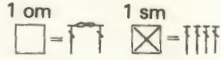

MATERIALS:
Crochet cotton no. 10, white, about 310 yds. Steel crochet hook US size 9 or SIZE FOR GAUGE.

GAUGE:
2" square = 9 meshes and 9 1/2 rows.

GAUGE: 2" square = 9 meshes x 9 1/2 rows

TO MAKE:
Ch 49 + 5 to turn (3 ch count as first dc and 2 ch form first open mesh or om). ROW 1: Dc in 9th st from hook, then work * 2 ch, sk 2 sts, dc in next st, rep from * across = 16 om in all; ch 5, turn each row. ROW 2: 3 om, 2 solid meshes <sm> (= * 2 dc in ch-2 lp, dc in next dc, rep from * once more), 11 om. ROWS 3-387: Work following pat diagram. At end of row 387, fasten off.

79" (387 rows) 7 grps of 2 leaves

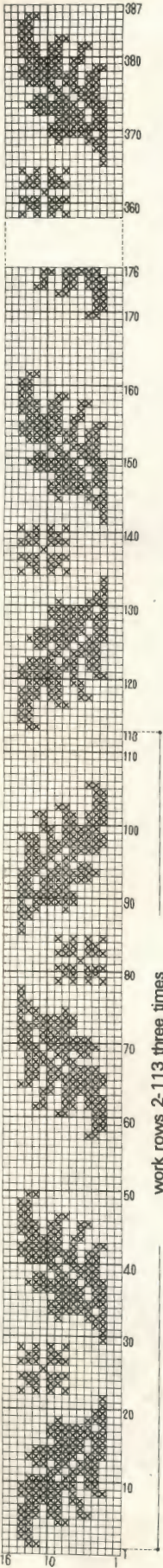

work rows 2-113 three times and rows 2-51 once

3 1/2"
beg ch : 49 sts
(16 meshes)



How to follow the diagrams

Crocheting involves only a limited number of stitches, but by combining them you can create many different patterns. We have devised a system of symbols for the stitches, and these symbols are used in a pictorial diagram of each pattern or motif. From the diagram you can see the degree of difficulty of each project, and you can tell at a glance how far along you are by checking your work against the diagram. While you may be unfamiliar with this approach to crocheting, we feel sure that, with a bit of practice, you will find it much quicker and easier than a row-by-row description method.

To get your project working smoothly, read the instructions and consult the abbreviations. As you proceed with the aid of the diagram, keep checking back to the CROCHET BASICS section at the end of the magazine for the symbols.

Take, for example, the diagram shown here. Rows or rounds are numbered in lightface; a boldface number inside a loop tells you how many chain stitches to make in that loop. The abbreviation for chain

stitch is ch, or ch st, and the symbol is O. In this sample diagram, you can see that in Round 1 a loop has 6 ch, while a loop in Round 3 has 9 ch. In Round 4, you are working in groups of 9 treble crochets, for which the abbreviations is tr and the symbol is $\overline{\text{T}}$. Only part of Round 3 is given in detail. That is because the same series of stitches is repeated all the way around. Likewise, only one petal is shown in full detail, because the same pattern is repeated each time. Arrows indicate the direction of work. Note that some patterns will require special symbols, and these will appear alongside the diagram with an explanation.

The additional diagrams - completed work, details of edging, etc. - will assist you in making more advanced crochet projects.

You are now ready to try your hand at any of our lovely patterns. A word of advice: Always read the instructions carefully before you begin. They may contain information on a fancy stitch, or on edging or assembling, that is not shown in the diagram.

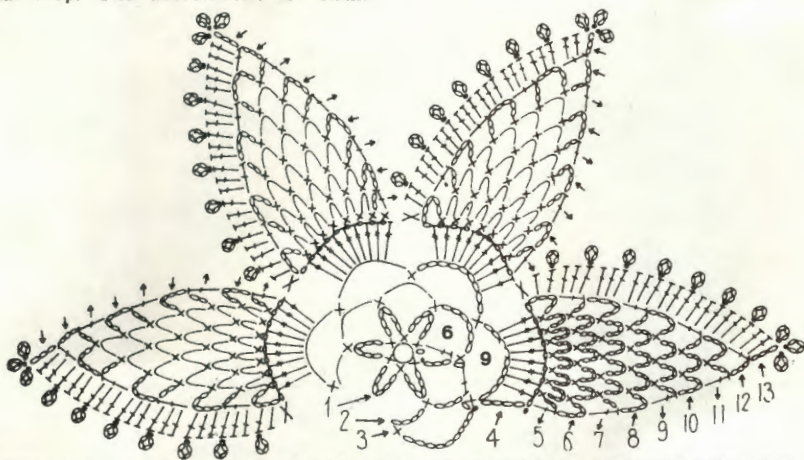

Sample gauges for classical threads

Six-cord crochet cotton number	American hook size	Size of swatch
5	7	3" x 3" = 33 dc x 15 rows
10	8	3" x 3" = 36 dc x 16 rows
20	9	3" x 3" = 40 dc x 16 rows
30	10	3" x 3" = 45 dc x 18 rows
40	11	3" x 3" = 47 dc x 19 rows

For information on buying threads write to (enclose SASE):

In the USA

BUCILLA, Attn: Yarn Design, 150 Meadowlands Pkwy, Secaucus NJ 07094.

COATS & CLARK, Consumer Service Dept, 6900 Southpoint Dr. N., Suite 200, Jacksonville FL 32216.

COTTON CLOUDS, Route 2, Desert Hills Nr 16, Safford AZ 85546.

DMC CORPORATION, Port Kearny Bldg Nr 10, South Kearny NJ 07032-0650.

In Canada **COATS**, 337 Evans Avenue East, Etobicoke ON M8Z 1K2.

All about cottons and hooks

There are many types of crochet thread on the market, and several types of hooks. To help you choose the right yarn and the right hook, here is a description of the more common crochet cottons, with their yardage, and a chart of hook size equivalents. Keep in mind that your individual crocheting style may call for a slightly thicker or thinner hook than the one recommended for a specific project.

CLASSICAL THREAD: Six-cord crochet cotton is available in several colors and thicknesses (the higher the number, the finer the thread), and it is tightly twisted. Four-cord, three-cord or uncorded thread is less expensive and easy to obtain.

Each ball weighs 20 grams, or approx. 3/4 of an ounce.

No. of cotton thread	International hook size	American hook size
3 (83 yds)	1.75	4
5 (111 yds), 10 (124 yds)	1.50	8
15 (136 yds), 20 (174 yds), 30 (216 yds)	1.25	10
40 (249 yds), 50 (286 yds)	1.00	12
60 (324 yds)	1.00	12 or 0.75 or 14
70 (361 yds), 80 (398 yds)	0.75	14
100 (472 yds), 120 (508 yds), 150 (584 yds)	0.60	16

FANCY YARNS: Each ball weighs 50 grams, or approx. 1 3/4 oz.

Cebelia: California cotton, 3-ply, with a sheen.

No. 5 (141 yds)	2.00	0
No. 10 (282 yds)	1.50	8
No. 20 (405 yds)	1.25	10
No. 30 (563 yds)	1.00	12

Fil d'Ecosse No. 5, 8-ply, special twist, with a sheen (184 yds) 2.00 0

Pearl cotton: Egyptian cotton, 2-ply, loosely twisted

No. 5 (266 yds)	2.00	0
No. 8 (482 yds)	1.50	8

Ordinary crochet cotton, 2-ply (230 yds) 1.75 4

Knitting cotton

No. 4: Egyptian cotton, 6-ply, with a high sheen (224 yds) 2.00 0

Soft knitting twist: California cotton, 5-ply, mat, loosely twisted. Gives a rustic look to your project. Various shades and thicknesses.

No. 4 (175 yds)	2.50	1
No. 6 (262 yds)	2.00	0

HOW TO WORK PATTERNS FROM OUR DIAGRAMS

On this page and the next, you will find the key abbreviations and symbols used in our diagrams and instructions. Step-by-step illustrations show newcomers how to work the basic stitches and techniques. Additional abbreviations or symbols needed for a specific project will be included and explained with that pattern. Note that, in each diagram, rounds or rows are numbered in lightface, while a boldface number inside a loop indicates how many chain stitches to work in that loop.

Abbreviations

beg	begin(ning)
bet	between
ch	chain (stitch)
ch-	chain(s) previously made
cont	continue
dc	double crochet
dec	decrease
grp(s)	group(s)
hdc	half double crochet
inc	increase
lp(s)	loop(s)
m	mesh(es)
p	picot
pat(s)	pattern(s)
prev	previous
rep	repeat(ing)
rd(s)	round(s)
RS	right side
sc	single crochet
sk	skip
sl st	slip stitch
sp(s)	space(s)
st(s)	stitch(es)
Tch	turning chain
tog	together
tr	triple crochet
WS	wrong side
yo	yarn over hook

CHAIN (also beginning chain)

(ch) or chain stitch
(ch st)

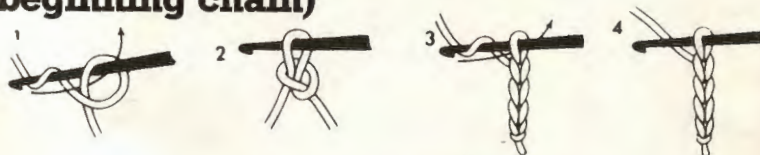

SINGLE CROCHET

(sc)
 Ch 1 to turn

Insert hook from front to back in next stitch under both upper strands, yarn over hook pull up loop (2 loops on hook), yarn over hook and draw thru 2 loops on hook.



SLIP STITCH

(sl st)



Used to form ch sts into ring, to join motifs and edges, to start loops in center of previous loops, and so on.

HALF DOUBLE CROCHET

(hdc)



Ch 2 to turn.



DOUBLE CROCHET

(dc)



Ch 3 to turn



TRIPLE CROCHET

(tr)



Ch 4 to turn.

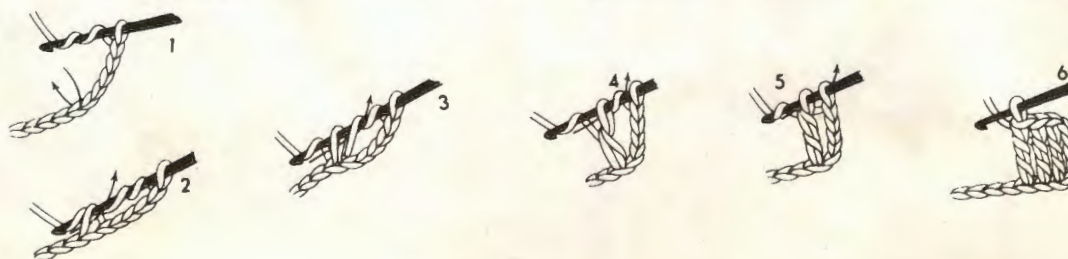

THREE WAYS TO MAKE A PICOT (p)

Work desired number of extra ch sts, then continue in original st (1). Work extra ch sts, then join with sl st (2) or sc (3) in first st of picot chain.

1. 



2. 

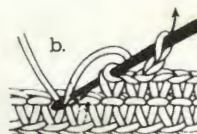
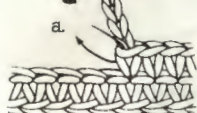

3. 



THREE WAYS TO BEGIN

1. Work ch, join with sl st to form ring.

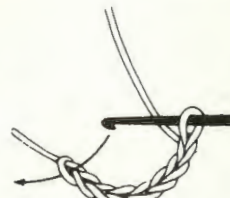
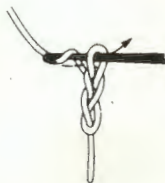
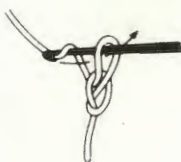
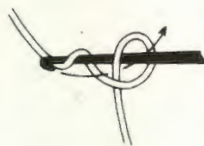

2. Form loop with end of yarn.

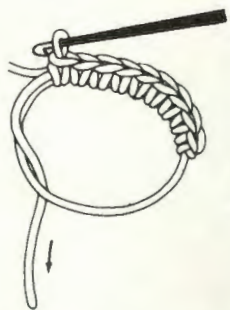
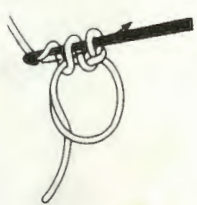
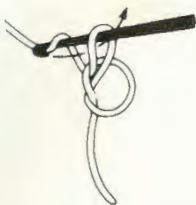
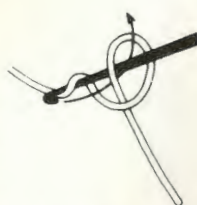

3. Form double loop with end of yarn.

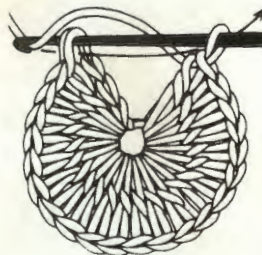
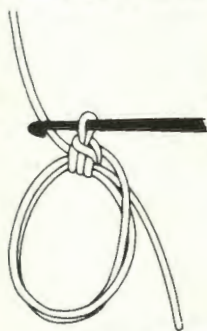
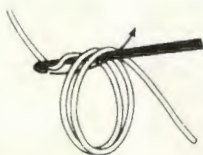

RAISED HALF DOUBLE CROCHET (R hdc)

Yarn over hook, insert hook from front to back to front around stem of st below, yarn over hook, pull up loop, complete as hdc. Work R dc or R sc in same manner.



FASTEN OFF

with hook

a.

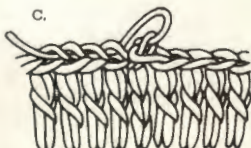
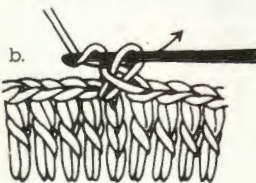
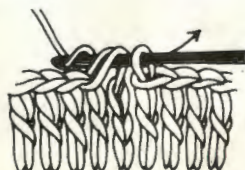

FASTEN OFF

with needle

a.

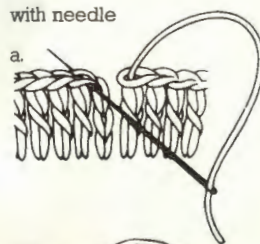

b.



ATTACH YARN

CUT YARN

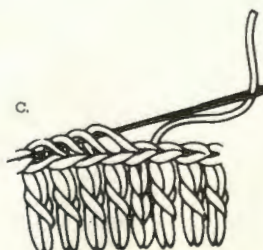

3 ALONE

By Jeanne Fancello

SIZE:
7 1/2" in diameter + swan measuring 3 1/2" by 3 1/2".

MATERIALS:
Crochet cotton no. 5, white, about 111 yds. Steel crochet hook US size 6 (size 4 if you tend to work tightly) or **SIZE FOR GAUGE.** Small amount pearl crochet cotton no. 5 in each color: orange for beak and blue for eyes. Small amount absorbent cotton for stuffing swan.

GAUGE:
First 3 rnds measure 2 3/8" in diameter.

TO MAKE
SWAN: Complete swan first, following diagrams and how-to. As of 2nd row of wings and body, insert hook in back strand only of sc below. Work body for 10 rows; ch 1, turn each row. **RND 11:** At end of row 10, ch 5, fold body WS tog, work dc in first sc of row 10 (see bold type on diagram), ** 2 ch, sk next st, dc in next st, rep from ** 10 more times; end with 2 ch, close with sl st in 3rd st of ch-5. **RND 12:** Same as rnd 11, working dc in each dc and in each open mesh <om>; close same as on rnd 11. Fasten off (see black wedge).
MAT: Ch 8 and join with sl st to form ring. **RNDS 1-10:** Work following diagram. Up to rnd 6, close each rnd with sl st in top of ch-3 (= first dc throughout); on rnds 3-6, cont with 2 sl sts to beg new rnd in 3rd dc. On rnd 7, last 3 ch sts = dc in first sc. On rnds 8-10, last 4 ch sts = tr. **RND 11:** Work (10 ch, sc in next ch lp) 5 times, 5 ch, sc in corresp om at base of swan, 5 ch, work (sc in next ch lp, 10 ch) twice, sc in 5th st of next ch lp, 18 ch, sk next 3 om at base of swan, sc in next om, work (3 ch, sc in next om) 18 times, 18 ch, sk 2 sc on rnd

11, sc in next sc on 11th rnd, 17 ch, turn, sc in first ch-3 lp, work (4 ch, sc in next ch lp) 17 times, 17 ch, sc in same st as sc outlining last ch-10 lp, 16 ch, turn, work 2 more rows around swan

joining them to mat with sc in same st as bef, then cont rnd 11 around mat as per tiny arrows; close with sl st in closing tr below. Fasten off (see black wedge).

FINISHING: Assemble and stuff swan. Spray pieces with mixture of water and starch. Spread on flat surface covered with clean soft cloth. Stretch to size and pin in place. Allow to dry thoroughly before removing pins.

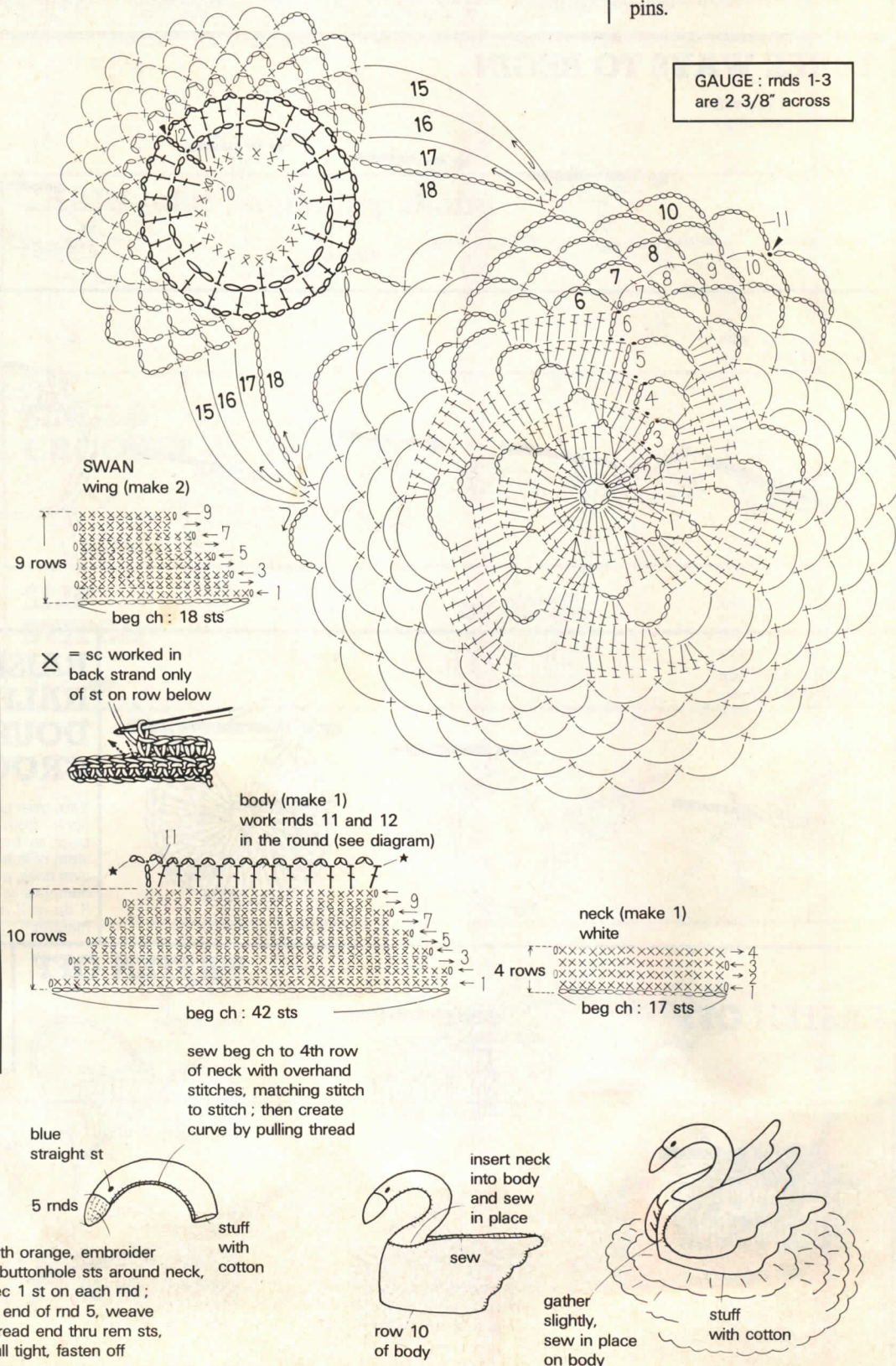



4

SWANS TOGETHER

By Jeanne Fancello

SIZE:
15 3/4" in diameter.

MATERIALS:
Crochet cotton no. 5, white, about 420 yds. Steel crochet hook US size 6 (size 4 if you tend to work tightly) or SIZE FOR GAUGE. Pearl crochet cotton no. 5, blue (for eyes) and orange (for beak), small amount in each color. Absorbent cotton for stuffing swan.

GAUGE:
First 3 rnds measure 2 3/8" in diameter.

TO MAKE
SWAN: Complete six swans first, following diagrams for "Swan Alone" project. As of 2nd row of wings and body, work sts in back strand only of sc below. Work body in rows up to row 10. At end of row 10, ch 5, fold body in two with WS tog, work dc in first sc on row 10. Now cont in the round with rnd 11: work (2 ch, sk next st, dc in next st) 11 times, end with 2 ch; close with sl st in 3rd st of ch-5. Work rnd 12 (see bold type) same as rnd 11, having dc in each dc and in each open mesh; close same as on rnd 11, fasten off. Assemble each swan following diagrams.

CENTER MAT: Ch 10 and join with sl st to form ring. RND 1-14: Work following diagram. Up to rnd 7, close each rnd with sl st in top of ch-3 (= first dc throughout), and, on rnds 3 to 7, cont with 2 sl sts to beg new rnd in 3rd dc. On rnds 8 and 9, last 3 sts = dc in first sc (end of rnd 8) or in closing dc (end of rnd 9). On rnds 10 to 12, last 4 ch sts = tr in closing st below. On rnds 13 and 14, last 5 ch sts = double triple crochet (= yo 3 times, then complete same as dc, that is, yo and draw thru lps on hook 2 by 2). While working rnd 14, join to rnd 12 of each swan with sc in corresp ch-2 lp as

shown. RND 15-18: Work sc and ch lps following diagram; close each rnd with sl st in first sc. At end of rnd 18, fasten off (see black wedge). FINISHING: Spray completed project with mixture of water and starch. Shape and stretch to size. Allow to dry.

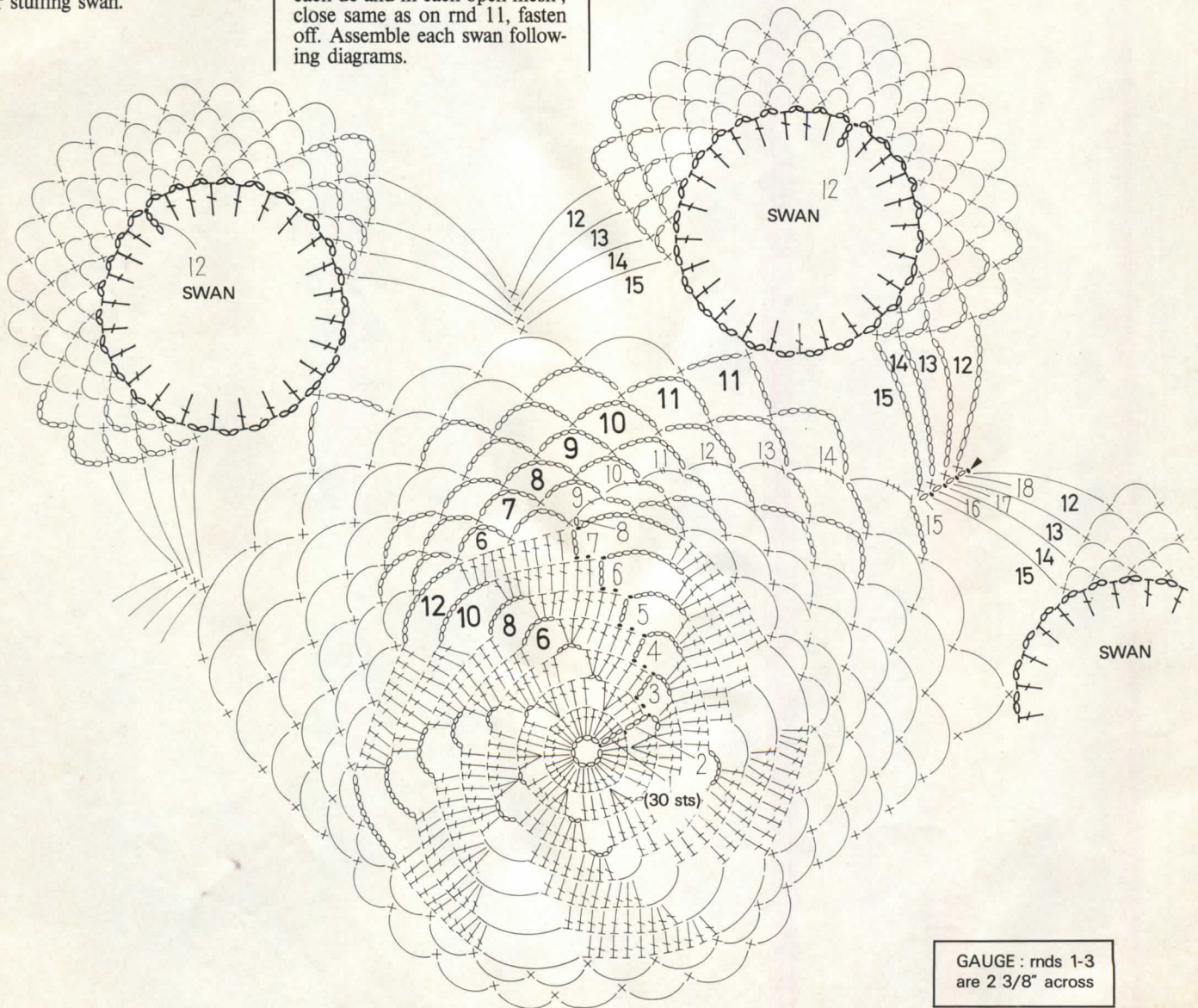



5

SOLSTICE

SIZE:
9 3/4" in diameter.

MATERIALS:
DMC Special Cordonnet (Art. 151) crochet cotton no. 20, white, 87 yds. Steel crochet hook US size 9 or **SIZE FOR GAUGE.**

GAUGE:
Each motif measures 2 1/4" by 2 1/4".

TO MAKE
MOTIF (6 in all): Ch 10 and join with sl st to form ring. **RND 1:** First dc = 3 ch throughout. In ring work * 4-dc cluster <cl> (use same cluster principle as for 3-dc cl), 13 ch, 4-dc cl, 8 ch, rep from * twice more; last 4 ch sts = tr in top of first cl. **RND 2:** ** Beg with 3rd st of next ch lp, work * 5 ch, 3-dc cl (see how-to), rep from * 4 more times, cont with 5 ch, sc in next

ch lp, rep from ** twice more; last ch lp = 2 ch, dc in top of closing tr below. **RND 3:** Work (5 ch, sc in 3rd st of next 5 ch sts) 18 times; last sc = sl st in top of closing dc below. Fasten off (see black wedge).

BORDER: RS facing, attach thread with sl st in ch lp of 2nd motif (see white wedge). **RNDS 1-7:** Work following diagram. On rnd 1, end with 7 ch + quintuple triple crochet (= yo 6 times, pull up lp in first sc, * yo and draw thru 2 lps on hook, rep from * 6 more times). On rnds 2-4, last 3 ch sts = dc. On rnd 4, work (5 ch-5 lps, 1 ch-6 lp) 12 times. On rnd 5, last 2 ch sts = hdc. On rnd 6, last ch st = 1 sc. On rnd 7, close with sl st in top of first cl. Fasten off (see black wedge).

FILL-IN: Ch 10 and join with sl st to form ring. Work as per bold type, place in center and join to adjacent motifs with sl sts

as shown; close with sl st in top of first cl. Fasten off (see black wedge).

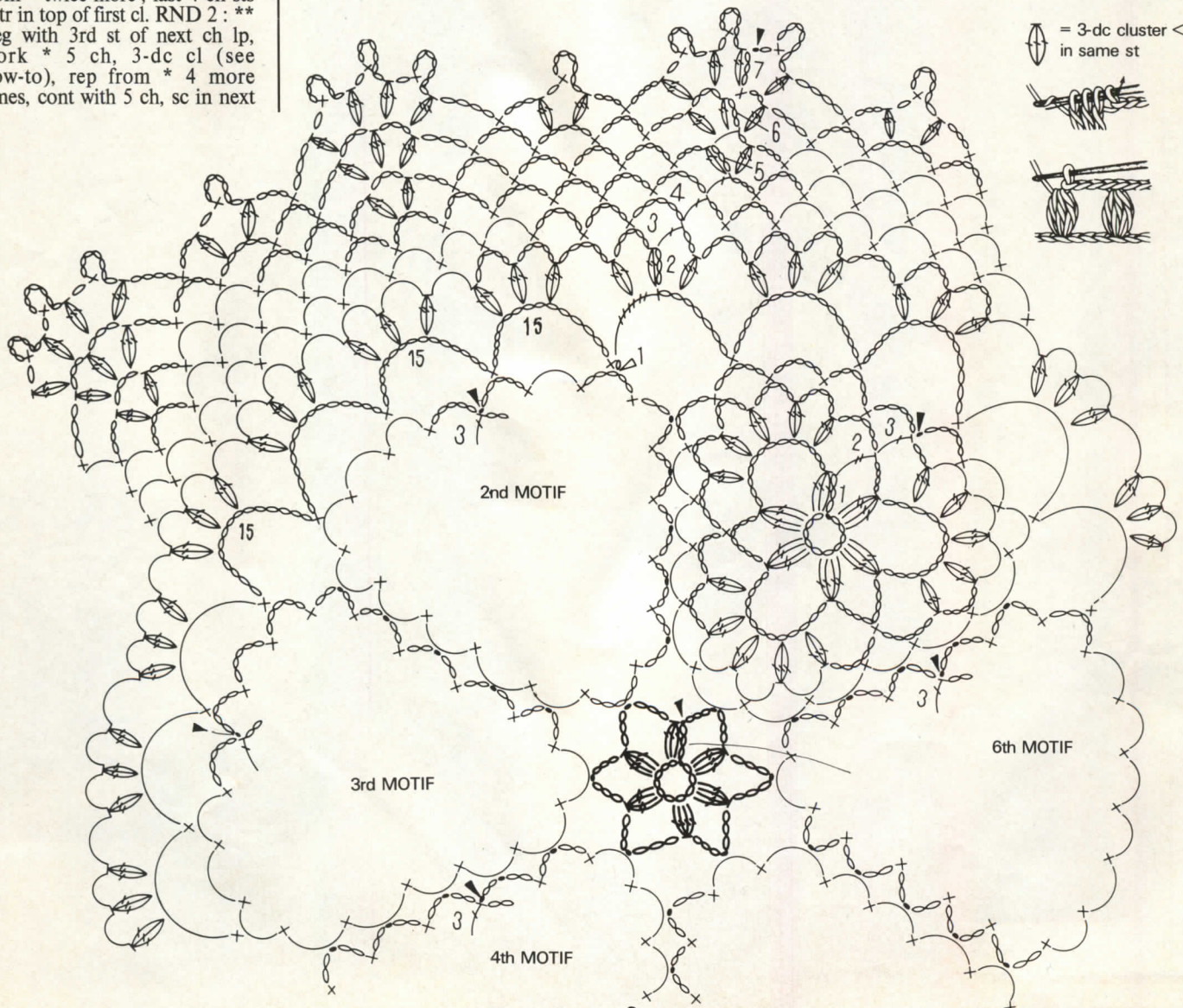
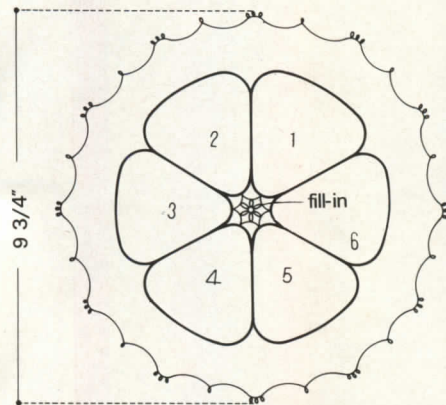

 = 3-dc cluster <cl> in same st



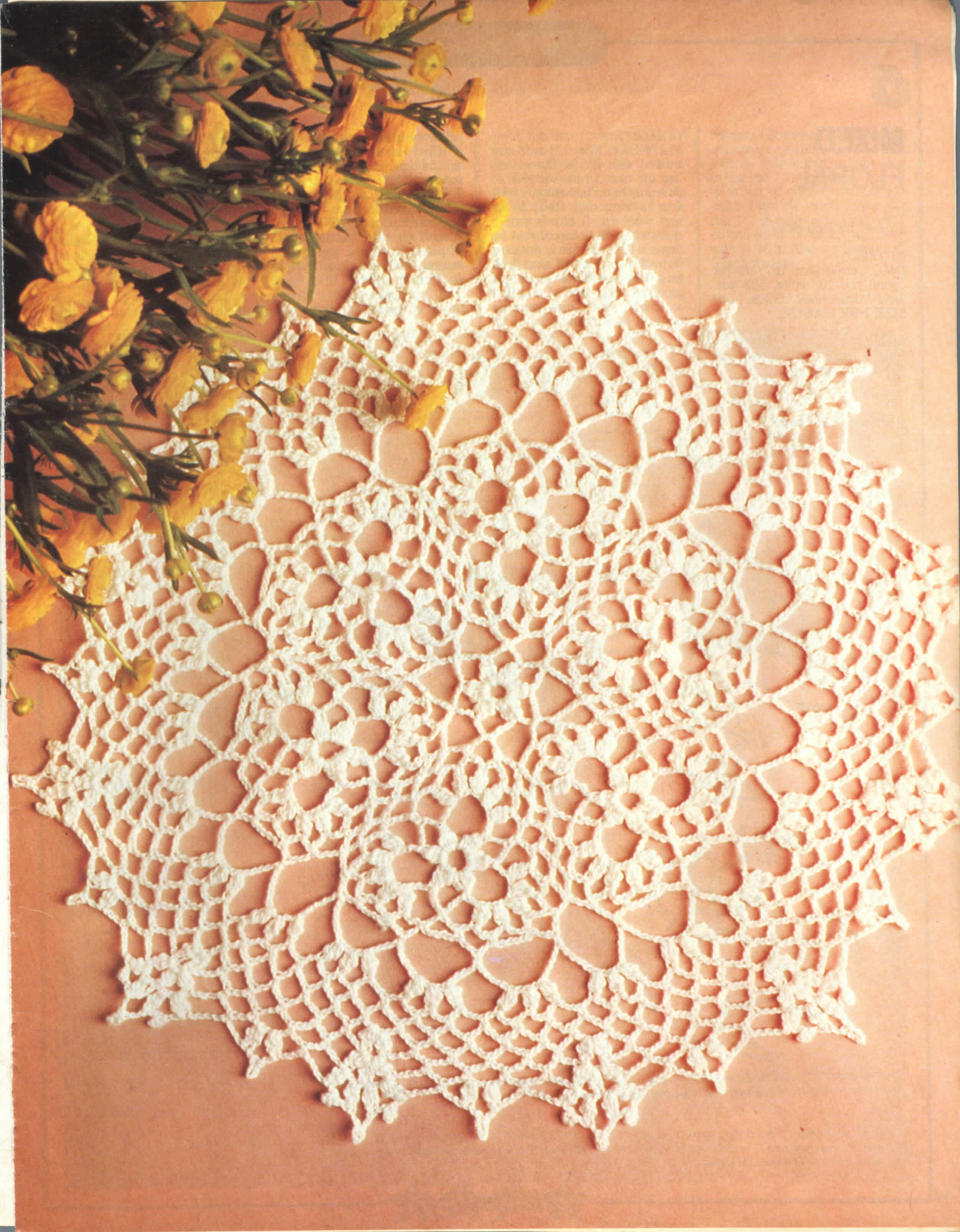

6

MIXED FLORAL

SIZE:
18 3/4" on each side.

MATERIALS:
DMC Cebelia (Art. 167) crochet cotton no. 20, white, 608 yds. Steel crochet hook US size 11 or SIZE FOR GAUGE.

GAUGE:
First 5 rounds of a flower are 2 3/4" in diameter.

TO MAKE
FLOWER: First 2 rnds are worked with WS of flower facing, the next 5 rnds with RS of flower facing. Ch 8 and join with sl st to form ring. RND 1: In ring work (tr, 3 ch) 8 times; close with sl st in top of ch-4 (= first tr). RND 2: Ch 1, work (sc in tr, 4 sc in each of next 2 ch lps) 4 times = 36 sts in all; on each rnd, close with sl st in first sc. RND 3: Ch 1, turn, inserting hook in back strand only of sts

below work sc in each sc. RND 4: Ch 1, work (sc in each of 2 sc, 15 ch, sc in same st as last sc, sc in next sc) 12 times. RND 5: * 5 hdc, 17 dc and 5 hdc in ch lp, sl st in 3rd sc of next 4-sc grp, rep from * around. RND 6: 14 sl sts, 1 ch, then * sc in 14th st of petal, 15 ch sts, rep from * around. RND 7: Ch 1, ** sc in sc, 7 ch, tr in 8th st of ch lp, * 7 ch, 2-tr cluster <cl> (= leaving last lp of each st on hook, work

1 tr in top of last tr and 2nd tr in same st of ch lp as bef, yo and draw thru all 3 lps on hook; use this cluster principle to work 5-dc and 2-dtr cls of border), rep from * twice more, 7 ch, rep from ** around; close with sl st in first sc. Fasten off (see black wedge). As of 2nd motif, join on rnd 7 at 2 ch lps thus: replace 4th st of center ch-7 lp with sl st in corresp ch lp of adjacent motif. Join all 9 motifs in this way as per motif arrangement diagram.

4 = insert hook in st(s) to which symbol points

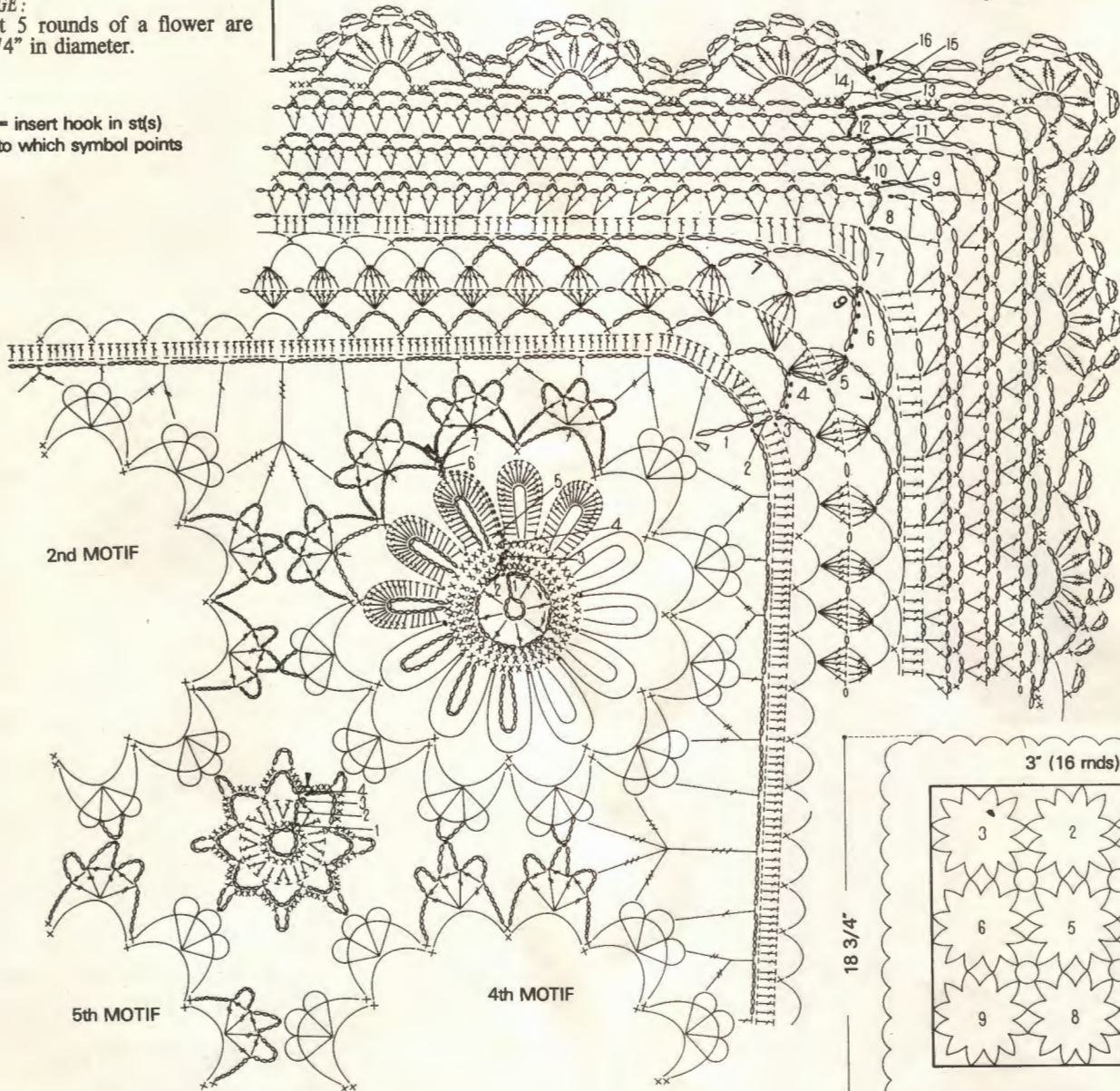

Upside-down "Y": yo 3 times, pull up lp in ch lp, work "yo and draw thru 2 lps on hook" twice, yo twice, pull up lp in next ch lp, rep from * to * 3 times, yo and draw thru all 3 lps on hook

Fork: yo 7 times, ** pull up lp in next ch lp, work (yo, draw thru 2 lps on hook) 3 times, * yo 3 times, rep from **, then rep from ** twice more (= 9 lps on hook), yo, draw thru 4 lps on hook, then work (yo and draw thru 2 lps on hook) 5 times

 = 5-dc cl

 = 2-dtr cluster <cl>

FILL-IN (4 in all): Ch 10 and join with sl st to form ring. **RNDS 1-4:** Work following diagram. On rnd 4, join with sl st at 4 ch lps to corresp ch lps of 4 adjacent flowers; close with sl st in first sc. Fasten off (see black wedge).

BORDER: RS of joined motifs facing, attach thread with sl st in corner ch lp as per white wedge. **RNDS 1-16:** Work following

diagram and additional symbols. On rnd 1, work ** dc + 6 ch + dc in corner ch lp, then, having ch-6 lp bet joining sts throughout and inserting hook once in each ch lp of flowers, work *upside-down "Y", dc* 3 times in first flower, fork bet 2 flowers, dc, rep from * to * 3 times across 2nd flower, fork, then *dc, upside-down "Y"* 3 times across 3rd

motif, rep from ** around; close with sl st in top of ch-3 (= first dc throughout). On rnd 2, work dc in each st and 2 dc in 3rd and 4th ch sts at corners. On rnd 3, across sides, sk 5 sts bet sc and form corner as shown = 26 ch-7 lps on each side and one ch-9 lp at each corner. On rnd 4, work dc grps in 4th st of ch-7 lps and in 4th and 6th sts of ch-9 lp at

corners. Close with sl st throughout except on rnd 14, where last 3 ch sts = dc in first sc to be able to beg rnd 15 in center of 2nd ch lp to left of corner. On rnd 15, work 2-dtr cls in ch-7 lps. On rnd 16, in each ch lp work sc, 3 ch and dc in top of last sc; close with sl st in first sc. Fasten off (black wedge).



7

MOSAIC

SIZE:
31 1/2" on each side.

MATERIALS:
DMC Cebelia (Art. 167) crochet cotton no. 20, white, 1,985 yds.
Steel crochet hook US size 9 or
SIZE FOR GAUGE.

GAUGE:
First 4 rnds measure 1 3/4" in diameter.

TO MAKE
MOTIF (16 in all): Ch 6 and join with sl st to form ring. RND 1: In ring work (tr, 3 ch) 8 times; close with sl st in top of

ch-4 (= first tr throughout). RND 2: Ch 1, in each ch lp around work 4 sc; close with sl st in first sc. RND 3: Work following diagram. On rnd 3, replace last 4 ch sts with tr worked in first sc; close other rnds same as on rnd 2. RND 6: Ch 1, ** sc in sc, 13 sc in ch lp, cont with first petal thus: * ch 1, turn, sk 1 st, sc in each st on row below, rep from * 11 more times, then work downward across side of petal with sl sts (that is, 1 per row), rep from ** around, joining each petal to last petal at end of 6th row of sc thus: ch 7, sl st in 7th row of last petal, ch 1, turn, 4 sc + 1 picot + 4 sc in ch lp, 1 ch, sk first st of petal you are working on, and end petal in same way as last

petal; join 8th petal to first petal at end of 7th sc row in same way.

RND 7: Ch 1, work * sc in sc of petal, 19 ch, sc in next petal,

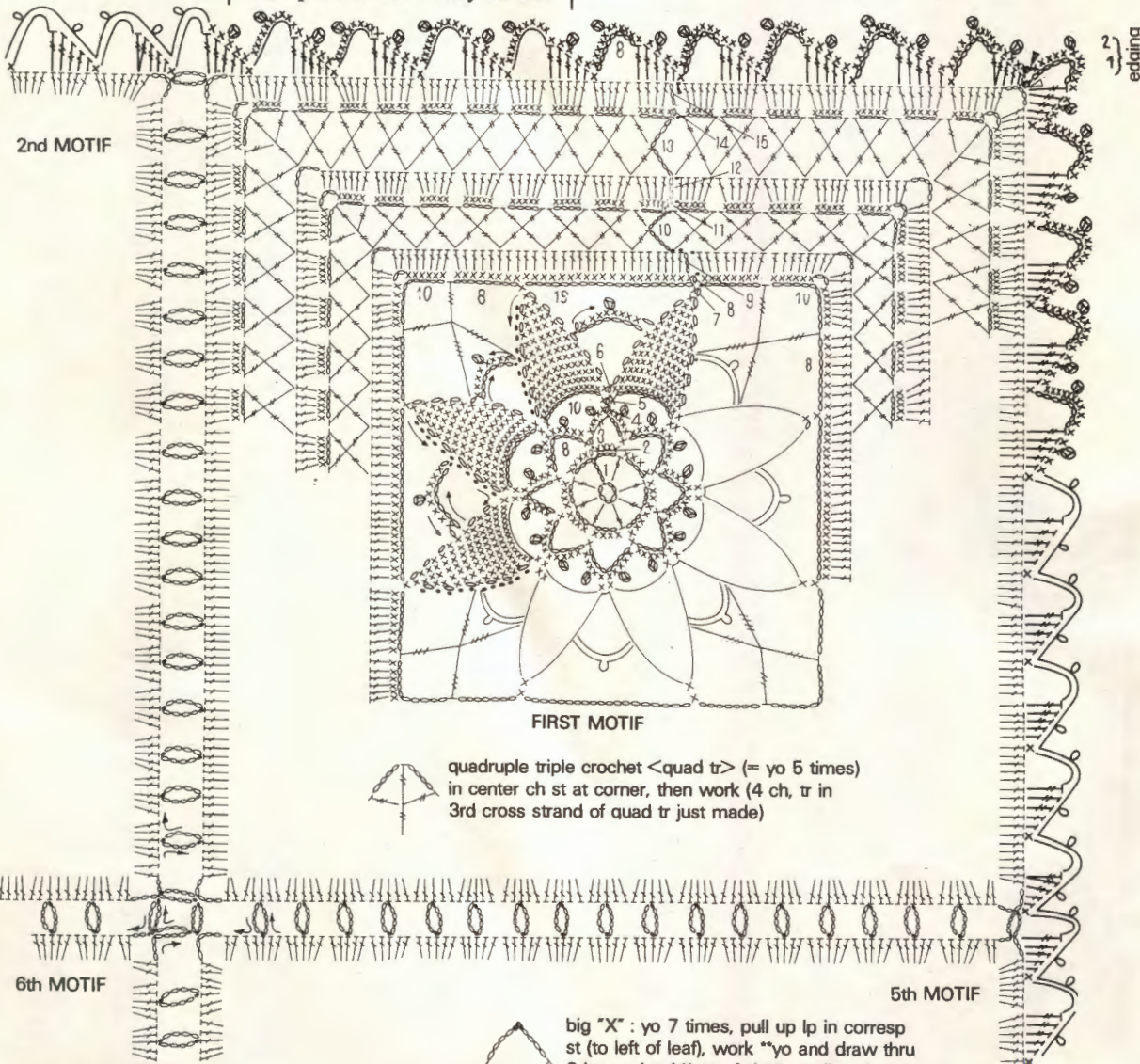
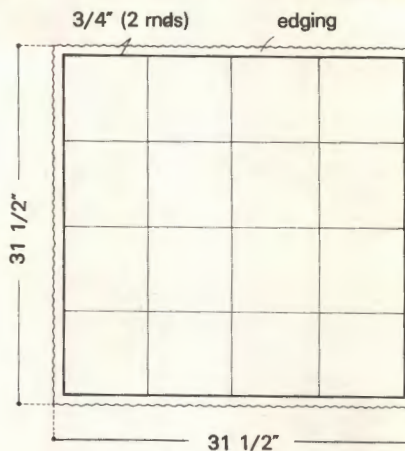

quadruple triple crochet <quad tr> (= yo 5 times) in center ch st at corner, then work (4 ch, tr in 3rd cross strand of quad tr just made)

small "X": yo 4 times, pull up lp in same st as bef, work "yo and draw thru 2 lps on hook", yo twice, sk 4 sts, pull up lp in next st, rep from * to * 6 times, 4 ch, tr in center of "X"

big "X": yo 7 times, pull up lp in corresp st (to left of leaf), work "yo and draw thru 2 lps on hook", yo 4 times, pull up lp in corresp st to right of next leaf, rep from ** to ** 9 times, 10 ch, yo 3 times, pull up lp in center of "X", rep from ** to ** 4 times



PATCHWORK

8 ch, big "X" (see additional symbol), 8 ch, rep from * around; close each rnd with sl st. RND 8-15: Work following diagram. On rnd 8, work 20 sc in ch-19 lps, 8 sc in ch-8 lps, and 6 sc + 2 ch + 6 sc in corner ch lps. On rnd 10, beg with sl st in

each of next 2 dc, then, on this rnd and on rnd 13, work 4 ch, sk 4 dc, tr in next dc, 8 ch, tr in top of last tr (first little "X" made), cont working little "X"s and corners as per diagram and special symbols; close these rnds with sl st in 4th st of ch-8 forming first

"X". On rnd 15, work dc in each sc and 2 dc + 5 ch + 2 dc in each corner ch lp; close with sl st in top of ch-3 (= first dc throughout). Fasten off (see black wedge). As of 2nd motif, join on rnd 15 thus: on every 5th dc work 4 ch, sl st in corresp st of

adjacent motif, 4 ch, sl st in top of last dc; at corners work 7 ch, sl st in 3rd ch st of adjacent motif, 4 ch, sl st in 3rd st of ch-7 just made and 2 ch (bet 4 motifs, follow tiny arrows to join). Assemble 4 rows of 4 motifs each in this way.



8

SYMPHONY

SIZE:
45" on each side.

MATERIALS:
DMC Cebelia (Art. 167) crochet cotton no. 20, white, 2,875 yds. Steel crochet hook US size 9 or **SIZE FOR GAUGE.**

rnds). **RNDS 3-8:** Insert hook in ch lps and work following diagram. On rnd 8, close with sl st in top of closing dc below; Fasten off (see black wedge). As of 2nd motif, on rnd 8 join thus: replace center st of ch lps with sl st worked in corresp ch lp of adjacent motif(s). Join 3 rows of 3 motifs each in this way to form the **CENTER SQUARE**. Also join remaining 24 motifs to form a frame.
RNDS 1-25: RS facing, attach thread with sl st in first ch lp to left of corner ch lp of Center Square (see white wedge). Work following diagram and additional symbols; close with sl st through-

out. On rnd 1, work 32 ch-5 lps across each side and one ch-7 lp at each corner. On rnd 2, work 4 sc in ch-5 lps and 7 sc in each corner ch lp. On rnd 3, work dc in each sc and 3 dc in 4th st of

ch-7 lp at corners. On rnd 4, work sc in each dc and 3 sc in center dc of 3-dc grp at corners. On rnd 5, work ch-7 lps through-out; sk 4 sts bet, each sc and insert hook twice in center sc of

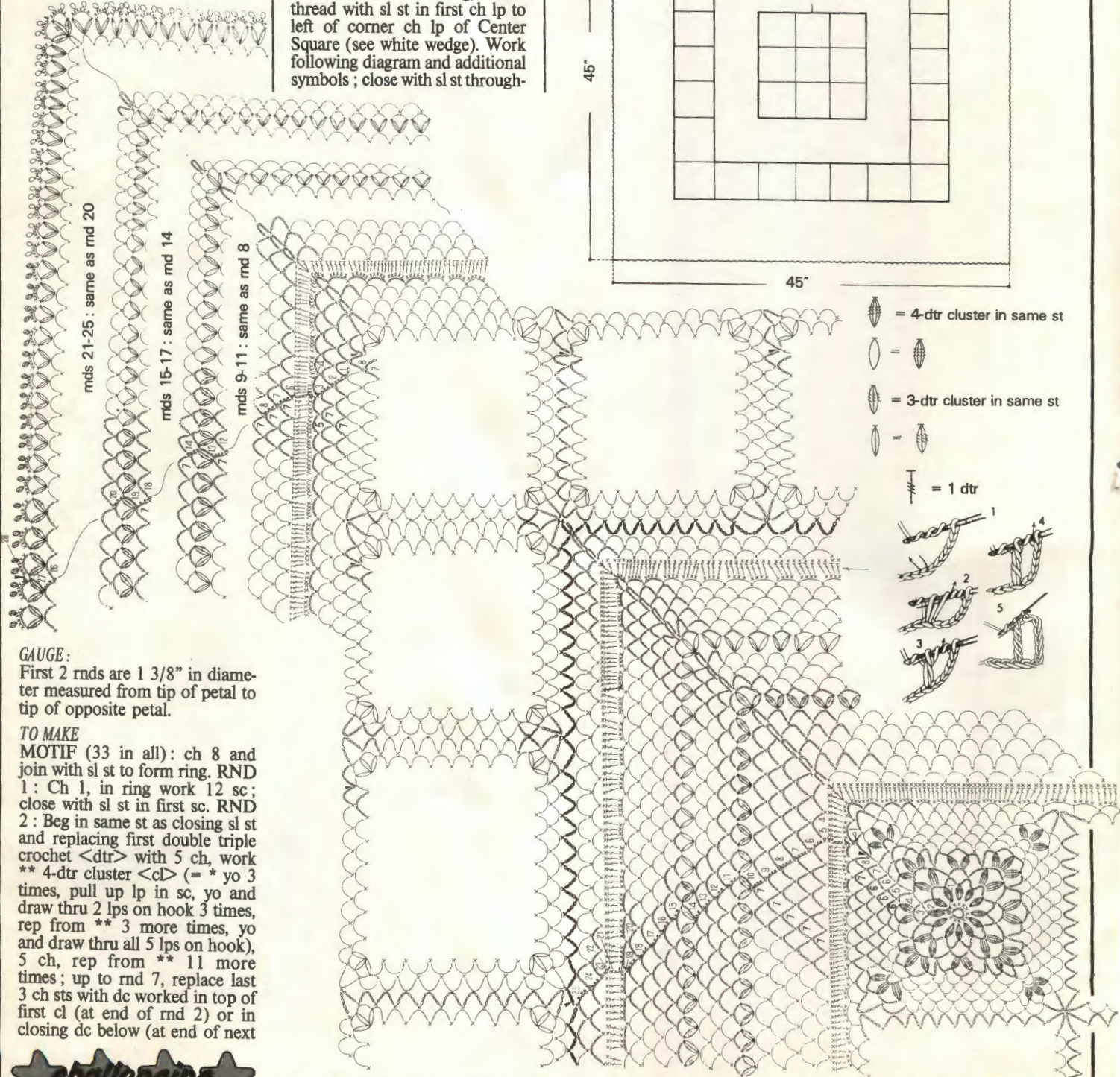
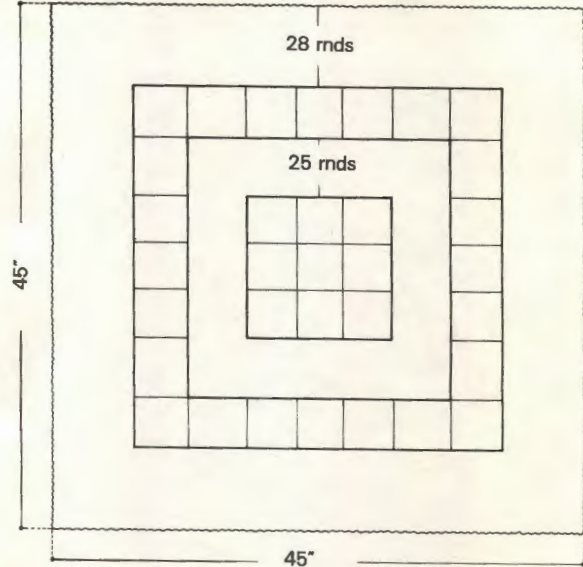

GAUGE:
First 2 rnds are 1 3/8" in diameter measured from tip of petal to tip of opposite petal.

TO MAKE
MOTIF (33 in all): ch 8 and join with sl st to form ring. **RND 1:** Ch 1, in ring work 12 sc; close with sl st in first sc. **RND 2:** Beg in same st as closing sl st and replacing first double triple crochet <dtr> with 5 ch, work ** 4-dtr cluster <cl> (= * yo 3 times, pull up lp in sc, yo and draw thru 2 lps on hook 3 times, rep from ** 3 more times, yo and draw thru all 5 lps on hook), 5 ch, rep from ** 11 more times; up to rnd 7, replace last 3 ch sts with dc worked in top of first cl (at end of rnd 2) or in closing dc below (at end of next

PATCHWORK

3-sc grp at corners = 28 ch lps on each side plus one ch lp at each corner. On next rnds, work sc and dtr in center st of ch lps and inc at corners as shown. On rnd 19, you should have ch-7 lp at each corner and 44 ch-5 lps on each side. On rnd 20, work 4

sc in side ch lps, 1 extra sc in one of these ch lps (shown in bold type on diagram), and 7 sc in corner ch lps. On rnds 21 and 22, work same as on rnds 3 and 4. On rnd 23, sk 3 sts bet each sc = 1 corner ch lp, 47 ch lps on each side. On rnd 24, you should

have 1 ch lp at each corner and 48 ch lps on each side. On rnd 25, join ch lps of rnd 24 to inside of MOTIF FRAME as per bold type; close with sl st in sl st. Fasten off (see black wedge). RND 1-28 : RS facing, attach thread with sl st in 3rd outer ch

lp to left of any corner of Motif Frame (see white wedge) and work following diagram. On rnds 7 and 27, insert hook in center st of ch lps. On rnd 28, work sc and picots <p> in ch lps. Close with sl st in first sc. Fasten off (see black wedge).



9

CHECKERS

SIZE:
30 3/4" on each side.

MATERIALS:
DMC Cebelia (Art. 167) crochet cotton no. 10, white, 1,525 yds.
Steel crochet hook US size 9 or
SIZE FOR GAUGE.

GAUGE:
First 9 rnds of motif measure
2 1/4" on each side.

TO MAKE
MOTIF (36 in all): Ch 8 and
join with sl st to form ring.
RNDS 1-12: Work following
diagram. On rnds 1 and 10, close
with sl st in top of ch-3 (= first
dc throughout). Close all other

rnds with sl st in first sc. On rnds
2-9, work sc in each dc or sc on
rnd below, sc + 4 ch + sc in each
corner ch lp. At end of rnd 12,
fasten off (see black wedge).

JOINING: As of 2nd motif, on
rnd 12 join thus: work sl st in
center of corresp ch lps and
picots of adjacent motif(s). Join
6 rows of 6 motifs each in this
way.

BORDER: RS of joined motifs
facing, attach thread with sl st in
picot <p> (see white wedge).
RND 1: Ch 1, sc in p, 11 ch, sc
in next p, 7 ch, sk next 2 corner
ch lps, dc in next ch lp, 5 ch, **
sk next ch lp, tr in next ch lp, 5
ch, sk next ch lp, dc in next ch
lp, 7 ch, sk 2 ch lps, sc in next
p, 11 ch, sc in next p, 7 ch, sk 2
ch lps, dc in next ch lp, * 12 ch,
sk next 3 free ch lps of next
motif, dc in next ch lp, 7 ch, sc

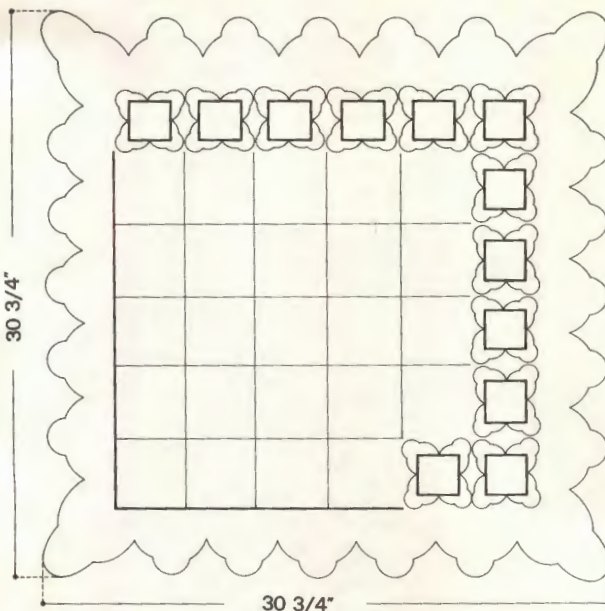

1 motif : 50 sts

30 3/4"

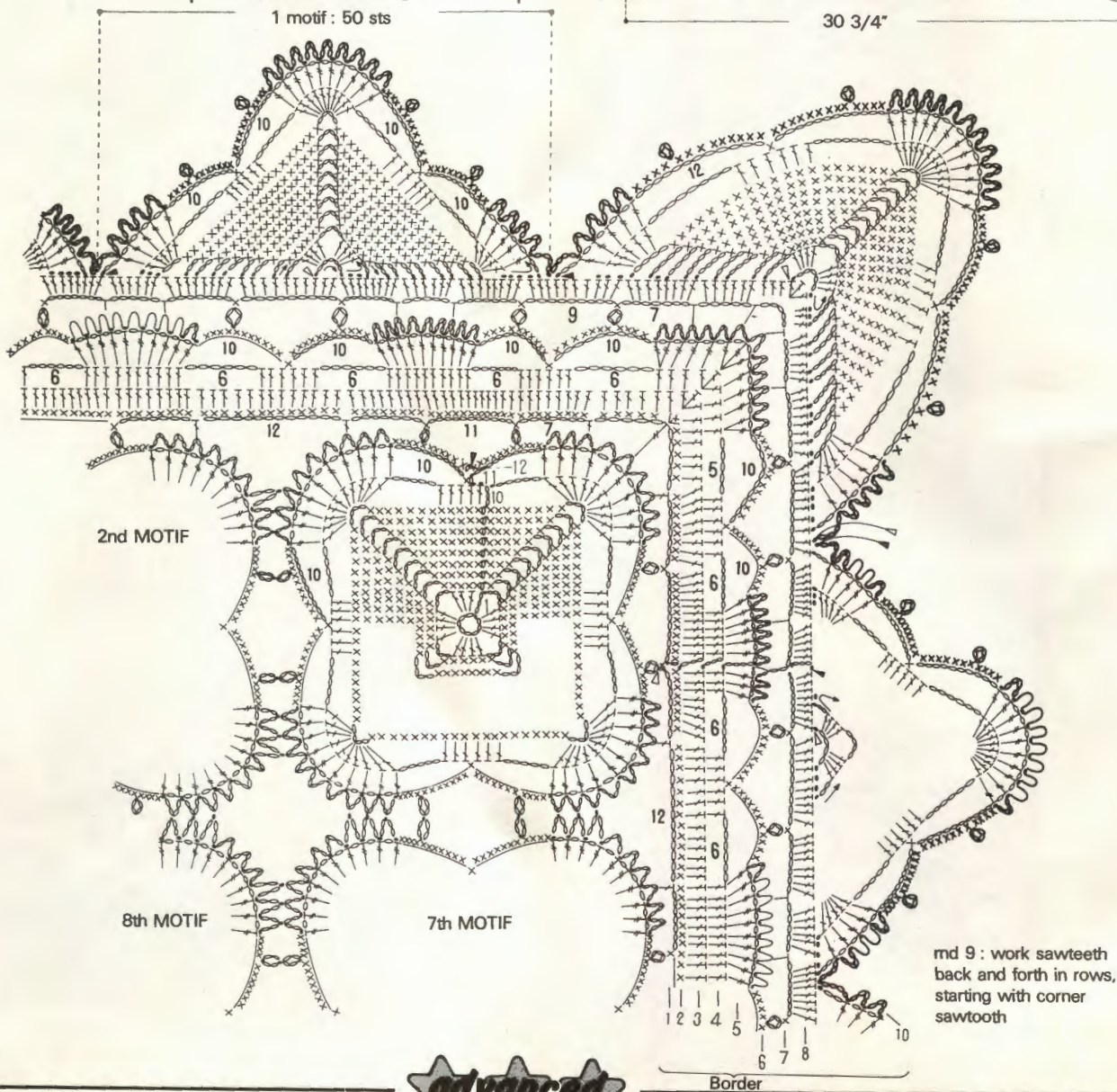

rnd 9 : work sawteeth
back and forth in rows,
starting with corner
sawtooth

in next p, 11 ch, sc in next p, 7 ch, sk next 2 ch lps, dc in next ch lp, rep from * 4 more times, 5 ch, rep from ** around; up to rnd 5, close each rnd with sl st in first sc, in top of ch-3, or in top of ch-4 (= first tr). RND 2: Sl st in first ch lp, work 12 sc in ch-11 lps, 8 sc in ch-7 lps, 5 sc in ch-5 lps at corner, 3 sc in corner tr and 13 sc in ch-12 lps = 3 sc at each corner and 243 sc on each side. RND 3: Dc in each sc and 3 dc in center sc at corners. RND 4: Bet last grp of 6 dc at

each corner and dc grp at corner, ch 5 and sk 5 sts; bet the other grps, ch 6 and sk 6 sts. RND 5-8: Work following diagram. On rnd 6, work sl st in top of tr and sc in ch lps; to replace last 2 ch sts work hdc in closing sl st below. On rnd 7, first hdc = 2 ch. On rnd 8, work 6 dc over ch-5 lps, 8 dc over ch-7 lps, 10 over ch-9 lps and 9 over corner ch lps; at end of rnd, fasten off (see black wedge). RND 9 (work each sawtooth separately in rows): WS facing, attach thread

with sl st in 4th dc of 9-dc grp at corner (see white wedge), ch 5, sk 1 st, sl st in each of next 4 sts, 4 ch, turn, work 4 dc + 4 ch + 4 dc in ch-5 lp at corner, cont with 4 ch, sk 2 dc, sl st in each of next 2 sts, 4 ch, turn, complete CORNER SAWTOOTH working back and forth in rows as shown and joining at end of each row with sl st to corresp dc on row 8; fasten off as per black wedge. WS facing, attach thread with sl st in 28th dc on rnd 8 (see white wedge), ch 5, sk 2 sts,

sl st in each of next 4 sts, 2 ch, turn, cont working back and forth in rows as shown; fasten off as per black wedge. Complete 5 identical sawteeth on each side and one at each corner. RND 10: RS facing, attach thread with sl st bet 2 sawteeth (see white wedge) and work 1 rnd edging as per bold type all around; close with sl st in attaching sl st. Fasten off (see black wedge).



10 BREEZE

SIZE:
About 50 by 80 inches.

MATERIALS:
DMC Hermina (Art. 991) crocheted cotton, white, 1,600 grams or 57 1/4 oz. Steel crochet hook US size 2 or **SIZE FOR GAUGE.**

GAUGE:
One motif measures 5" on each side.

TO MAKE MOTIF:
Ch 8 and join with sl st to form ring. **RND 1:** Ch 1, work (sc in ring, 5 ch) 5 times. **RND 2:** Work (sc in next ch lp, 5 ch) 4 times. **RND 3:** Work (2 sc in next ch lp, sc in sc; 5 ch) 4 times. **RND 4:** Work * 5 sc (that is, 2 in ch lp, 1 in each sc), 5 ch, rep from * 3 more times. **RNDS 5-14:** Work following diagram. On rnd 14, close with sl st in first sc. Fasten off.

TO ASSEMBLE MOTIFS:
As of 2nd motif, on rnd 14 join at 8 ch lps thus: replace center st of ch-5 and ch-7 lps, also 5th st of ch-10 lps with sl st worked in corresp ch lp of adjacent motif(s). Join 16 rows of 10 motifs each in this way.

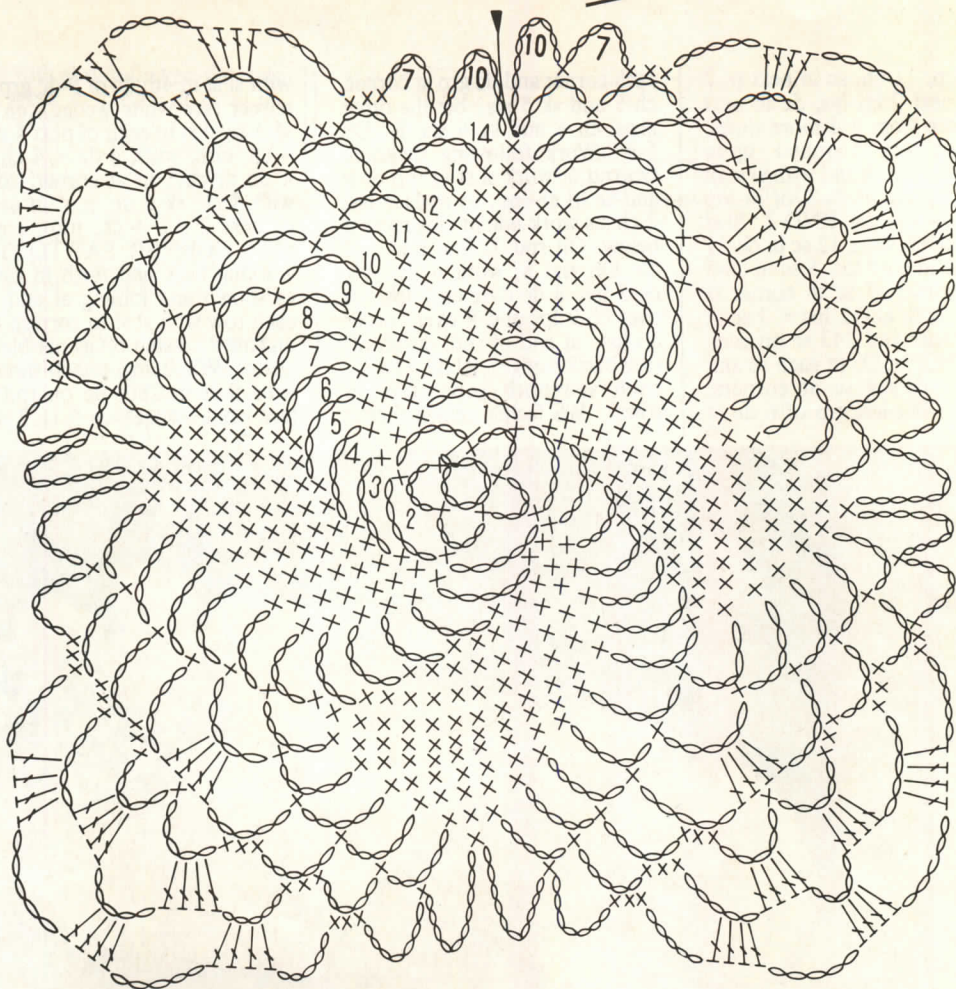

FINISHING, PRESSING AND STARCHING YOUR CROCHET PIECES FOR BEST RESULTS

You usually invest many hours to crochet a mat, a tablecloth, a café curtain or a garment. Naturally, you want the finished project to be as professional-looking as possible. One of our designers tells you how to go about it.

CHECKING AND CORRECTING

Secure all thread ends of the finished project. Make sure all edges are even. Correct the shape or position of stitches. Adjust the position of single-crochet groups or double crochets worked into the middle of a chain loop if they are off center. Do this carefully by moving the stitches gently with the tip of your finger. Examine your piece for spots. Check the size of the finished project.

WASHING

Smaller items, such as quick-to-make mats, rarely get soiled in the making. Larger projects that take a long time to complete will probably need freshening up by the time they are finished. If this is the case, proceed as follows.

- 1 - Wash first in cold water.
- 2 - Dissolve some detergent in warm water and allow the project to soak for

about five minutes. If you are washing a mat, immerse it without folding. Fold a big project in four or in eight before immersing. Swoosh item around, pressing lightly. 3 - Rinse well until water is totally clear (detergent residue can cause your project to turn yellow).

4 - It is very important not to wring your crochet piece. Place smaller items between two bath towels and gently blot out excess water. Fold tablecloths or other big projects in four or in eight and lay them out on a clean surface (or hang up over the bathtub). When there is no more excess water, spread them out to dry in a well-aired place.

TRACING FINAL OUTLINE OF PROJECT

For a round item, trace an actual-size circle on kraft paper, then trace even dividing lines for the required number of motifs. If your item is oval or square, trace outlines in the same way as you did for the circle.

STRETCHING AND PINNING

Spread a blanket on a flat surface (an ironing board, for example) and cover with clean white cloth. Put kraft paper with tracing on top. Spray crochet piece with water

to moisten. Spread item on top of tracing with right side facing you and pin center in place. Be sure to use guaranteed non-rust stainless steel pins. Continue to place pins in the center and along the outline of each motif, using dividing lines as your guide. Your moistened piece may tend to shrink somewhat, so you will have to stretch it gently into shape and place pins as closely together as needed. Note that the elastic nature of the blanket will prevent the weight of the iron from flattening out the stitches.

PRESSING

Moisten crochet piece once more, then spray with starch. Cover piece with clean white cloth and press gently from the center outward. Let dry thoroughly before removing pins.

Projects with ruffles. Pin flat area of item in place as per directions above. Spray with starch several times. Ruffles: spray, allow to dry, spray again. Repeat this process several times. When you have finished, remove all pins, spread ruffle on ironing surface and press gather by gather, moving the point of the iron from edge to inside of ruffle.

Popcorn-stitch motifs. Press project with right side facing but pinch popcorns with your fingers.

Tablecloths, table runners and bedspreads. Press one section at a time, then give unity to the whole by ironing all the joinings.

STARCHING PRODUCTS

There are several types available on the market.

Corn or chemical starch in powder form can be used as follows: dissolve starch powder in water, immerse a folded cotton hanky in this solution till saturated, then dab your piece with the hanky. This method will give your crochet creation a beautiful sheen.

Spray starch, however, is much more practical. It is easier to control the amount of starch applied and to spread it more evenly. Mats and centerpieces require plenty of starch. Projects with embossed motifs have to be sprayed very densely to maintain the relief shapes. Large-size projects for which thick or loosely-twisted thread was used should be starched very sparingly to prevent stiffness.



11

KNITTER'S SPECIAL

SIZE:
54" on each side.

MATERIALS:
DMC Hermina crochet cotton (Art. 991), white, 950 grams or about 34 ounces. Two single-point knitting needles US size 1.

NOTE:
Afghan consists of 81 squares, that is, 9 rows of 9 squares each. One square measures 5 inches on each side. Border is 4 1/2 inches deep.

TO MAKE
SQUARE: Knit following pat on Diagram 1. Cast on 1 st. **ROW 1:** Hold needle with cast-on st in left hand, pick up 2nd needle with right hand. Yo as per (b) instructions on Diagram 1, p1 on LH needle and turn. **ROW 2:** Yo as per (a) instructions on Diagr. 1, k2, turn. **ROW 3:** Yo (b), p3, turn. **NEXT ROWS:** Work following Diagr. 1. Work yo every other row at each edge of square. Loops formed by these yarn overs will be used to join the squares. For 36 rows, alternately work 4 purl rows and 4 knit rows as shown, then complete square with openwork pat. **ROWS 49-50:** Beg each of these 2 rows with sl 1. **ROW 51:** Beg row thus: sl 1, SKP; end row with k2 tog, k1. **ROW 52:** Beg with sl 1, then cont as shown. You will thus have sl 1 at each edge every other row, the loops formed by the slip stitches will be used later for joining the squares. **BORDER:** The border is a band consisting of 4 straight sections (that is, work even) plus 4 corners. **STRAIGHT SECTION:** Cast on 39 sts and, beg with edge st, work following Diagram 2. Rep from * to * 20 times, then work first 8 rows of Diagram 2. **CORNER:** Cont with short rows, as shown on Diagram 3. Across first 20 sts, alternate 4 purl rows and 4 knit rows, then knit across rem 19 sts. **SHORT ROWS:** They are worked as follows: ** 2 rows across first 20 sts, 2 rows across first 30 sts, 2 rows across 39 sts**, rep from ** to ** for 64 rows. Cont working rem 3 sides in same way. At end of last corner, bind off.

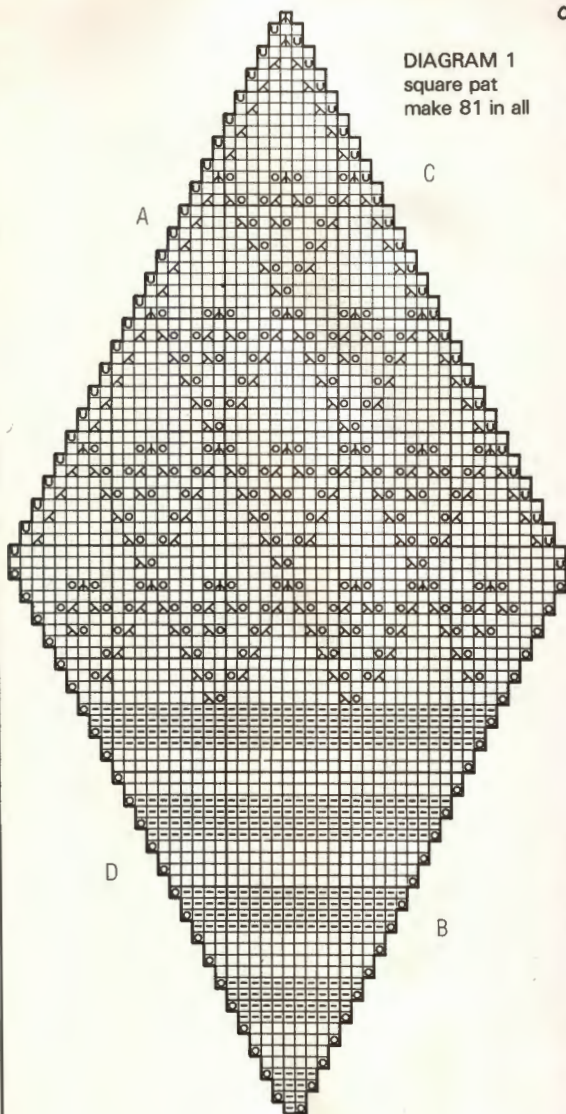
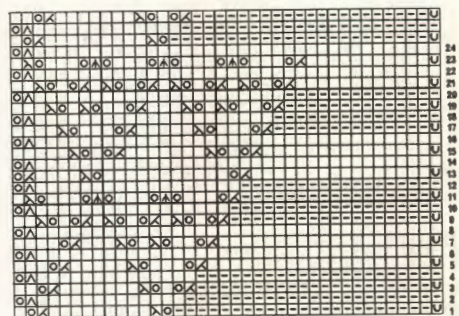

DIAGRAM 1
square pat
make 81 in all

o = yo
When "yo" symbol appears at beg of row, work thus:
(a) if "yo" is followed by k1, hold yarn taut in right hand, place RH needle on top of yarn, bring yarn to back over needle, k1 in first st on LH needle
(b) if "yo" is followed by p1, place RH needle under yarn, bring yarn to front wrapping it around needle, p1 in first st on LH needle

- ⊙ = yo
- △ = p2 tog
- = k1 on RS, p1 on WS
- ▢ = p1 on RS, k1 on WS
- ⊠ = k2 tog
- ⊞ = SKP: sl1, k1, pass sl st over
- ⊡ = double decrease: insert needle in next 2 sts knitwise, sl to RH needle, k next st, sl 2 sl sts over
- ⊔ = slip 1 <sl 1>

DIAGRAM 2
Border



38 sts

DIAGRAM 3
Border corner

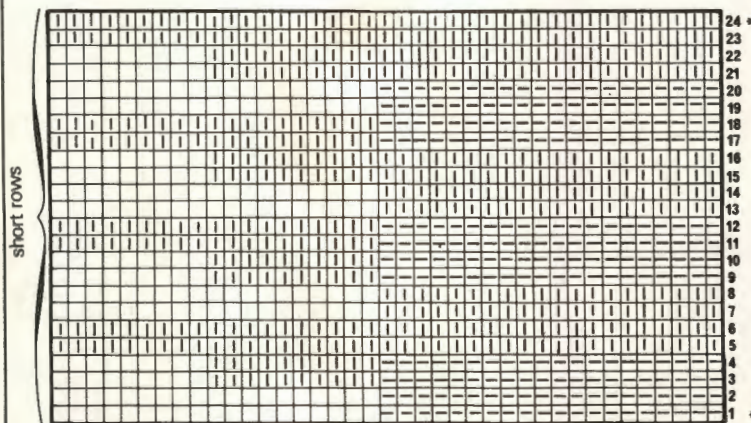

- ▢ = k1 on RS, p1 on WS
- ▣ = p1 on RS, k1 on WS

rep from * to * twice in all, then work once from row 1 to row 16

rep from * to *

ASSEMBLY : Secure and conceal all thread ends. Sew-join squares with overhand stitches placing tog edge A of one square and edge B of another square (see Diagr. 1). Insert needle alternately under yo of one square

and sl st of other square. This type of seam is invisible, forming an openwork row of its own. Sew-join 9 squares to form row in this way, complete 9 rows in all. Next, sew-join all 9 rows by placing edges C and edges D tog.

Now sew narrow edges of Border tog. Frame joined motifs with Border. RS tog, baste Border to squares, then sew with overhand stitches passing needle alternately in one then the other piece. Since one edge has yarn

overs and the other slip stitches, to obtain a neat seam insert needle under each yo and then under one strand of opposite sl st. Careful work will be rewarded with an openwork seam all around squares.



12

APPLAUSE

SIZE:
38 1/2 by 38 1/2 inches.

MATERIALS:
DMC Cebelia (167) crochet cotton no. 20, white, 2,795 yds.
Steel crochet hook US size 9 or
SIZE FOR GAUGE.

GAUGE:
One small motif inside square = 1 5/8" in diameter measured across tr. Each square measures 7 3/4" on each side.

TO MAKE
SQUARE MOTIF (9 in all): Start out with 9 round motifs. **ROUND MOTIF:** Ch 8 and join with sl st to form ring. Work 3 rnds as shown (first tr = 4 ch throughout); close each rnd with sl st. At end of rnd 3, fasten off.

As of 2nd motif, on rnd 3 join motifs with sl sts as shown. After all 9 motifs are joined, RS facing attach thread with sl st in corner as per white wedge, ch 1, work 6 sc in beg ch lp, ** then (sk first tr, sc in each of next 11 tr, 5 sc in each of next 2 ch lps) twice, sk 1 tr, sc in next 11 tr, 11 sc in ch lp, rep from ** around, end with 5 sc in beg ch lp; close with

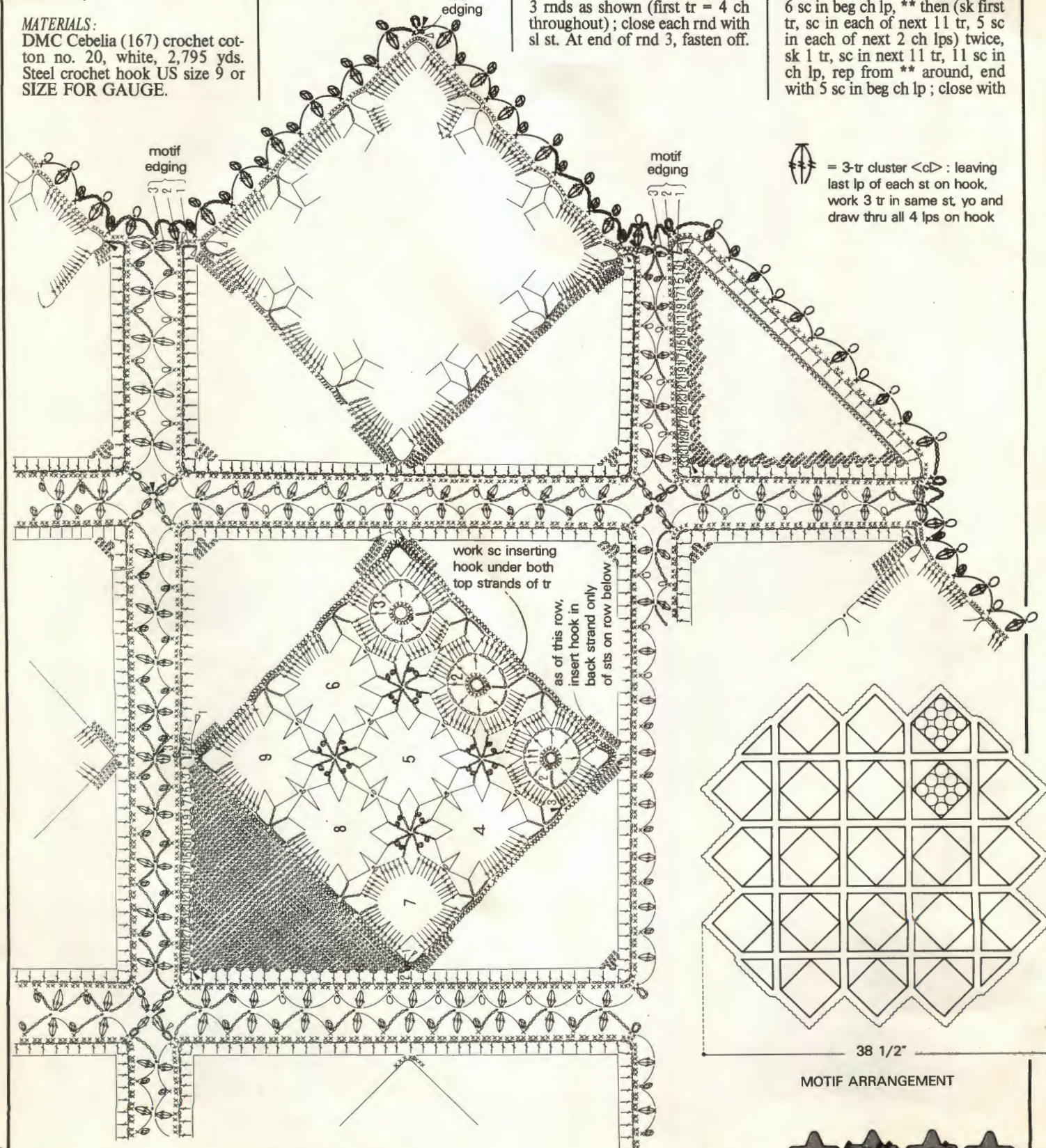

 = 3-tr cluster <cd> : leaving last lp of each st on hook, work 3 tr in same st, yo and draw thru all 4 lps on hook

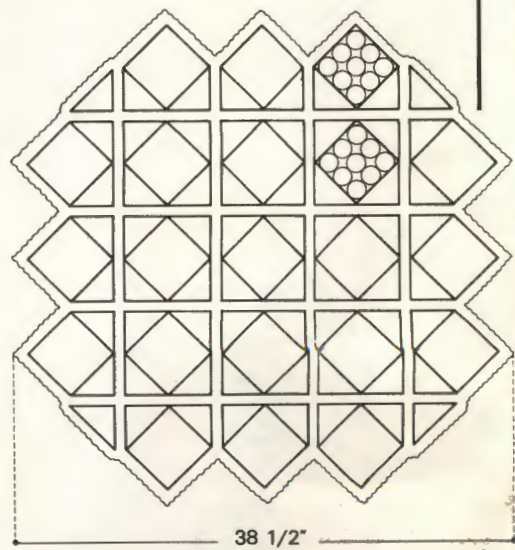

MOTIF ARRANGEMENT



sl st in first sc, ch 1, turn. Beg in last sc of rnd below and inserting hook in back strand only of each sc, complete 63 sc then cont TRIANGLE in sc, working back and forth for 33 rows; ch 1, turn each row, also sk first and last sc on each row until one sc remains (on row 33). Fasten off (see black wedge). Next, WS facing sk first sc of rnd on next side of square, attach thread with sl st in next sc, work in same way as bef. Complete rem 2 triangles in same way.

MOTIF EDGING: RS facing, attach thread with sl st in any

free sc on sc rnd (see white wedge) and work 3 RNDs all around square as shown (refer to additional symbol for 3-tr cl); on first 2 rnds close with sl st in top of ch-3 (= first dc on rnd 1) or in first sc. At end of rnd 3, close with sl st in top of first cl and fasten off (see black wedge). As of 2nd Square Motif, join on rnd 3 thus: after completing each cl, work sl st in top of corresp cl of adjacent motif(s) using Motif Arrangement diagram as your guide.

FILL-INS: Bet each 4 joined Square Motifs work thus: RS

facing, attach thread with sl st in corner picot (see white wedge) and work 3-tr cl in each of 4 picots; close with sl st in top of first cl, fasten off.

EDGE MOTIFS (12 in all, that is, 3 on each side): work sc triangles on 2 sides only. At end of first row of Motif Edging, fasten off. Now, RS facing, attach thread with sl st in top of ch-3 (= first dc) at beg of row 1 (see white wedge) and work sc rnd all around motif, then row 3 across 3 sides only, end with 4 ch, sl st in same st as last cl. Fasten off.

CORNER TRIANGLE (4 in all): Ch 63 + 1 to turn. ROW 1: Sc in 2nd st from hook and in each st across; ch 1, turn. ROWS 2-33: Work in same way as triangles for Square Motifs were worked. **MOTIF EDGING:** Work 2 rnds all around triangle, then 3rd row across 2 sides only as shown.

MAT EDGING: RS of joined motifs facing, attach thread with sl st in corner of any Edge Motif (see white wedge), ch 1 and work 1 rnd all around as per bold type; close with sl st in first sc. Fasten off.



13

AMBIANCE

SIZE:
11 1/4" on each side.

MATERIALS:
DMC Special Cordonnet (Art. 151) crochet cotton no. 30, white, 270 yds. Steel crochet hook US size 11 or **SIZE FOR GAUGE.**

GAUGE:
First rnd = 1 inch by 1 inch measured across petals from tip to tip. Each motif measures 2 1/4" on each side.

TO MAKE
MOTIF (25 in all): Ch 6 and join with sl st to form ring. **RND 1:** 4 ch count as first tr. Work ** 4-tr cluster <cl> (= * yo twice, pull up lp in ring, yo and draw thru 2 lps on hook twice, rep from * 3 more times, yo and draw thru all 5 lps on hook), 9 ch, dtr (see how-to), 9 ch, rep from ** 3 more times; last 5 ch sts = dtr in top of first cl. **RNDS 2-4:** Work following diagram. On rnd 2, work sc in 5th st of ch-9 lp, work tr in top of dtr; close each rnd with sl st (3 ch count as first dc). At end of rnd 4, fasten off (see black wedge). As of 2nd motif, on rnd 4 join thus: replace center ch st of picots with sl st worked in corresp picot of adjacent motif(s). Join all 25 motifs in this way.

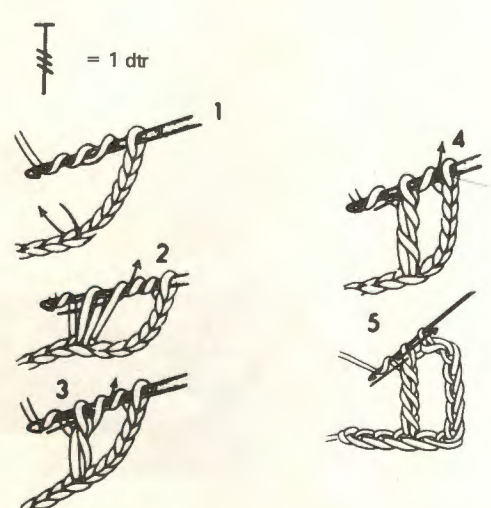
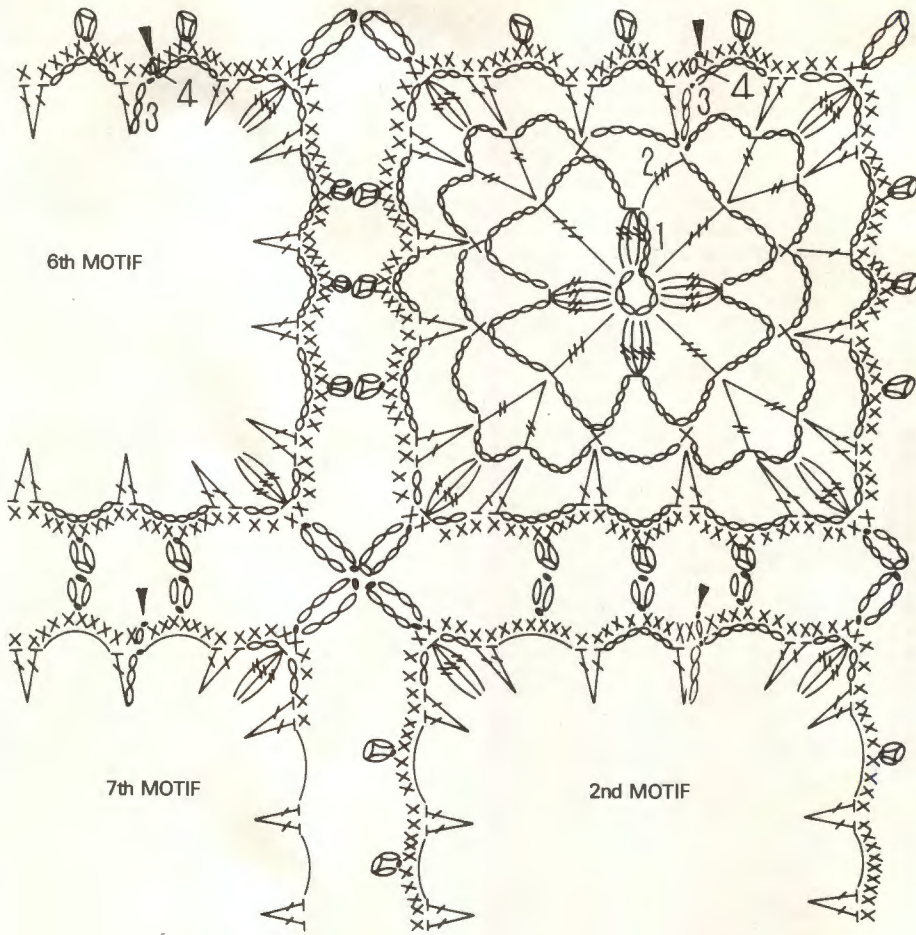

= 1 dtr

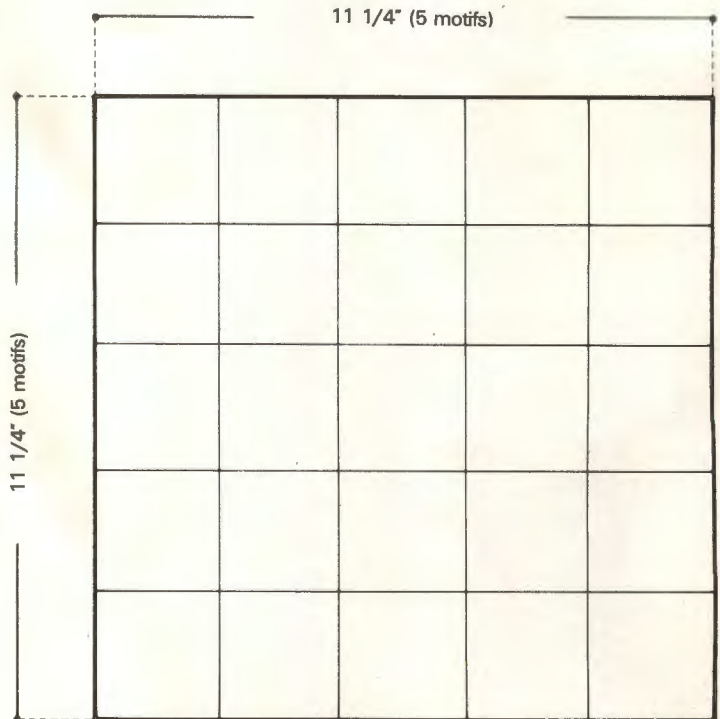



ARDOR

SIZE:
22 3/4" square.

MATERIALS:
DMC Cebelia (Art. 167) crochet cotton no. 30, white, 1,464 yds (= about 2 3/4 balls of 563 yds per ball). Steel crochet hook US size 11 or **SIZE FOR GAUGE.**

GAUGE:
First 3 rnds of motif measure about 7/8" in diameter.

TO MAKE
MOTIF (9 in all): Ch 8 and join with sl st to form ring. **RND 1:** Ch 1, in ring work 16 sc; close with sl st in first sc. **RND 2:** Work (dc, 1 ch) 16 times; close with sl st in top of ch-3 (= first dc throughout). **RND 3:** Ch 1, work sc in each dc and sc over each ch-1 lp = 32 sc in all; close same as on rnd 1, cont with sl st in next st, then ch 1, turn and, beg in same st as last sl st, work sc in each of 3 sts, turn again, complete 10 rows working back and forth as per diagram (inc

and dec as shown, for sc dec refer to additional symbol); at end of row 10, fasten off (see black wedge). **RS facing, sk next st on rnd 3, in next st attach thread with sl st and complete row 7 petals in same way as the first petal was worked. RND 5:** RS facing, attach thread with sl st in first sc of any petal, work (3 sc in petal, 15 ch) 8 times; close same as on rnd 1. **RND 6:** Sc in each sc, in each ch-15 lp work 5 sc + picot <p> (= 3 ch, sl st in top of last sc) + 7 sc + p + 5 sc; close same as on last rnd. Fasten off (see black wedge). **CORNER LEAVES and NEXT ROWS:** Work 6 rows sc as per bold type, cont with 2 rnds all around, complete each of 4 leaves separately with 12 more rows of sc. Fasten off. Complete rem 3 leaves in same way, at end of rnd 10, fasten off (see black wedge).

RNDS 11-14: RS facing, attach thread with sl st in sc as per white wedge and cont working in the round. On rnd 11, work tr in ch lps, dtr (see how-to) on each side of leaves and 3 sc in top of each leaf; close with sl st in top of ch-4 (= first tr throughout) and cont with sl st in first ch lp. On rnd 12, work 11 sc in each ch lp, 3 sc in top of each leaf. On rnd 13, work sc in each sc. On rnd 14, sk 1 st bet each dc and inc in each corner as shown. **RND 15:** Ch 1, work * sc in corresp mesh, 11 ch, sc in 4th st from hook, then, inserting hook once in each next st, work hdc, dc, 2 tr, 3 dtr, sk next 2 meshes, rep from * around; close with sl st in first sc. Fasten off (see black wedge). As of 2nd motif, on rnd 15 join thus: at tip of each sawtooth, replace 10th st of ch-11 with sl st worked in p of corresp sawtooth of adjacent motif(s).

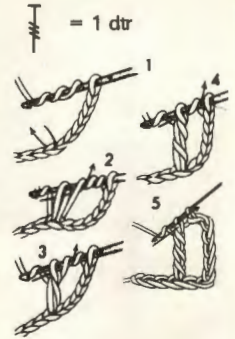
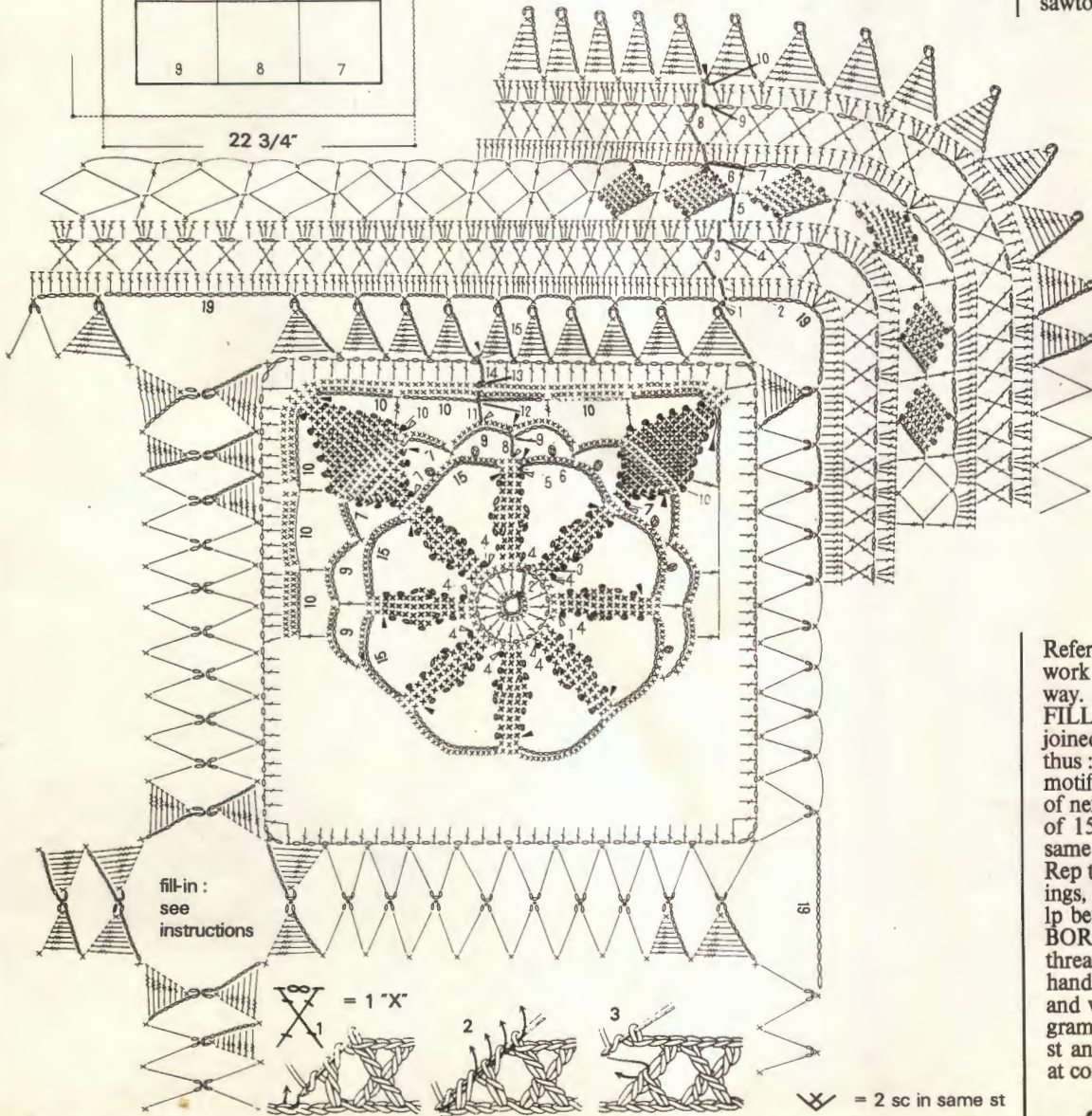
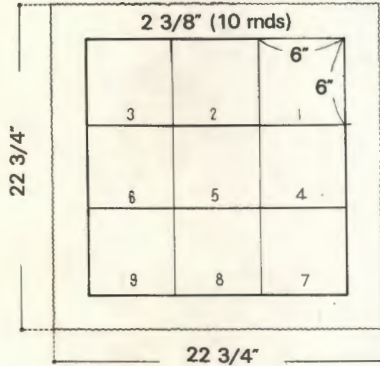

Refer to diagram of completed work and join all 9 motifs in this way.

FILL-IN: After all 9 motifs are joined, bet each 4 motifs work thus: sl st in joining sp bet 2 motifs, 15 ch, sl st in joining sp of next 2 motifs, turn, sc in each of 15 ch sts just made, sl st in same sp as first sl st. Fasten off. Rep this work in 2 opposite joinings, pass 2nd ch lp thru first ch lp before working last sl st.

BORDER: RS facing, attach thread with sl st in upper right-hand motif (see white wedge) and work 10 rnds following diagram. On rnd 2, work dc in each st and 3 dc in 10th st of 19 sts at corners; close with sl st in top

of ch-3 (= first dc) and cont with sl st in next dc. On rnd 3, ch 3, sk 2 dc, dc in next dc, 5 ch, dc in top of last dc; then work each "X" as per how-to, spacing them at corners as shown. Thus you should obtain 63 "X"es across each side and 7 ch at each corner

(after completing last corner "X", work next corner "X" by skipping only 1 st bet the 2 bottom dc). On rnd 5, complete 25 diamond motifs on each side and 1 at each corner thus: turn, work sl st in last dc on rnd 4, turn, * tr (4 ch count as first tr),

6 ch, sk next 4 dc, sc in next dc, 1 ch, turn, sc in sc, sc in each of next 6 sts, then (1 ch, turn, 7 sc) 5 times, sk 4 sts, rep from * around. On rnd 7, work 3 dc in corner sc, 7 dc in each ch lp located on each side of corner sc, 1 in each tr, 4 in each ch-4 lp

and 1 in each sc throughout. On rnd 8, work 67 "X"es on each side (that is, 1 every 4 sts) and 1 ch-5 lp at each corner. On rnds 9 and 10, work following diagram. At end of rnd 10, close with sl st in first sc. Fasten off (see black wedge).



MULTIWHIRL

By Elizabeth Hiddleston

SIZE:
Placemat, 15 3/4 x 10 1/2 ins.
Coaster, 4" from side to side.

MATERIALS:
Crochet cotton no. 10, ecru, about 275 yds for Placemat and Coaster (that is, about 25 yds per motif). Steel crochet hook US size 9 or **SIZE FOR GAUGE.**

GAUGE:
First 3 rnds of motif measure 1 5/8" in diameter.

TO MAKE
MOTIF (10 in all for Placemat):
Ch 8 and join with sl st to form ring. **RNDS 1-9:** Work following diagram; close each rnd with sl st in first sc or in top of ch-3 (= first dc). At end of rnd 9, fasten off. As of 2nd motif, on

rnd 9 join thus: replace 3rd st of each grp of 5 ch-4 lps with sl st worked in corresp ch lp of adja-

cent motif (see diagram). Join all 10 motifs in this way as per Motif Arrangement diagram.

MOTIF ARRANGEMENT

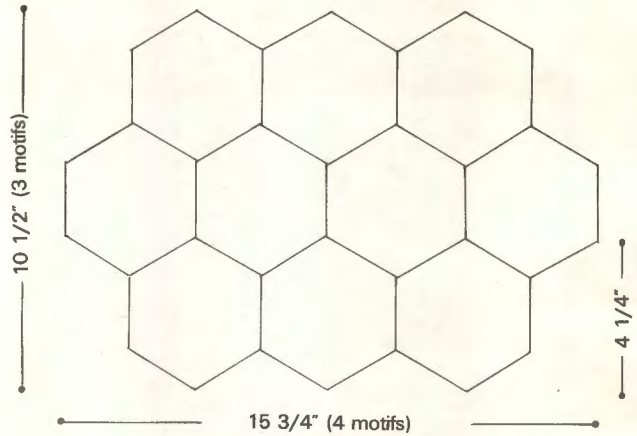

FIRST MOTIF

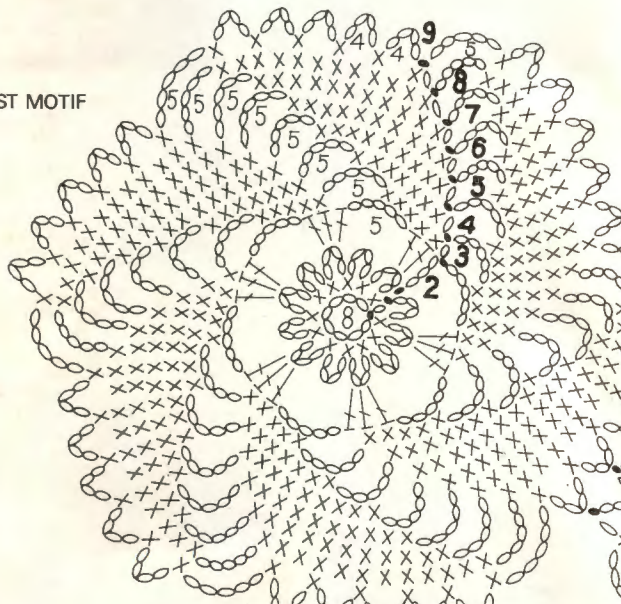

2nd MOTIF

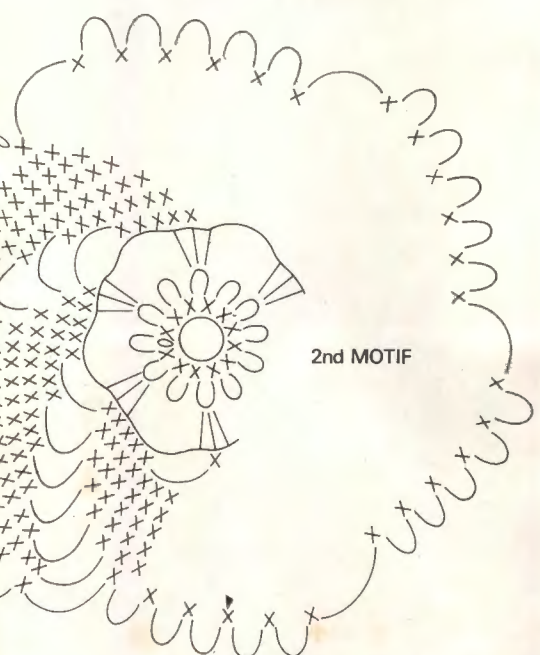

3rd MOTIF

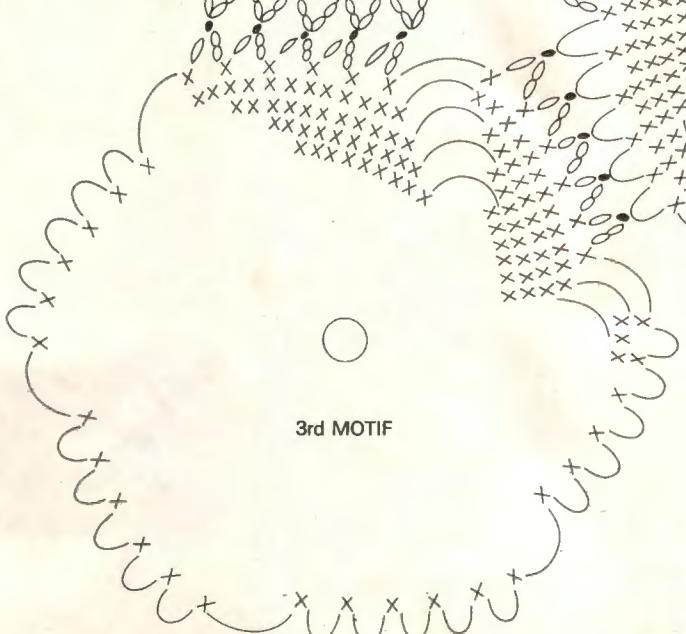

GAUGE: rnds 1-3 are 1 5/8" across

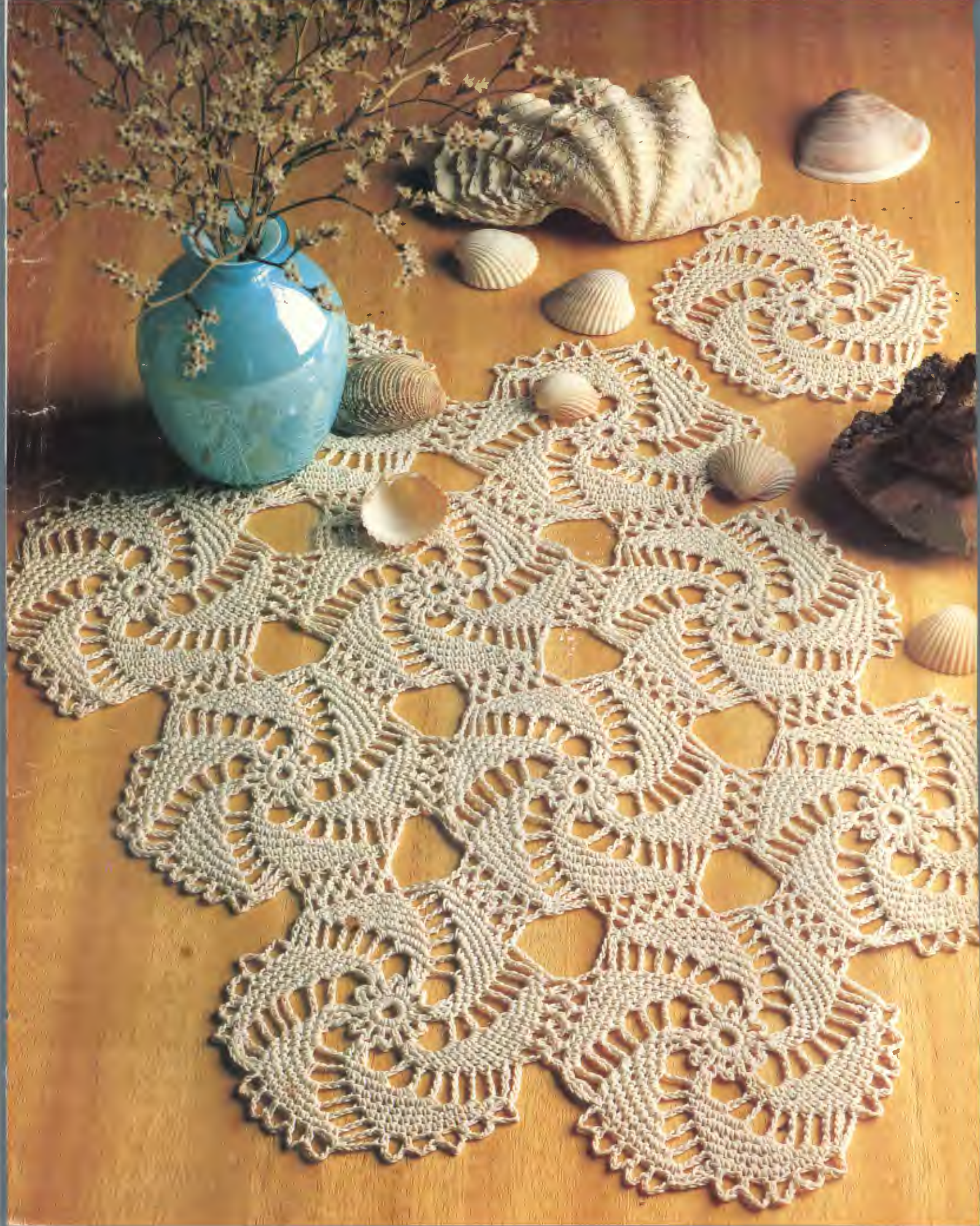

16

① FLORET LACE

DEPTH:
2 1/4 inches.

MATERIALS:
DMC Special Cordonnet (Art. 151) crochet cotton no. 20, white (about 130 yds for a 28-inch length). Steel crochet hook US size 9 or SIZE FOR GAUGE.

GAUGE:
One motif (13 sts) is one inch long. 2 rows dc are 3/8" high.

TO MAKE:
Ch 373 (or work chain length desired having multiple of 12 + 1); ch 1, turn. ROW 1: Sc in 2nd st from hook and in each st across; ch 4, turn. NEXT ROWS: Work following diagram and additional symbol for florets; ch as shown and turn each row. At end of rows 4 and 7 work trtr thus: yo 4 times, pull up lp in 3rd st of ch-4, yo and draw thru lps on hook 2 by 2. At end of row 9, fasten off (see black wedge). ROW 10: RS facing, attach thread with sl st in top of edge dc on row 3 (see white wedge) and work across 3 sides thus: sl sts across side edges, sc + picot in ch-6 lps. Fasten off as per black wedge.

② CURLICUE LACE

DEPTH:
3 1/2 inches.

MATERIALS:
DMC Special Cordonnet (Art. 151) crochet cotton no. 20, white (about 87 yds for each 11 1/2-inch length). Steel crochet hook US size 9 or SIZE FOR GAUGE.

GAUGE:
25 dc are 2" long and 1/4" high.

TO MAKE:
Beg with edge curlicues, ch 19 (= beg ch), then, following tiny arrows, work *** 2 dc in 5th st from hook, cont with **1 ch plus 2 dc separated by 1 ch in next st** twice, sk next st, work from ** to ** in next st, 13 ch, turn, sk next 2 shells <sh>, sl st

over ch-1 lp of next sh, 3 ch, turn, beg in first st of ch-13 lp work (dc in st, 2 dc in next st) twice, dc in next st, * 1 ch, dc in next st, rep from * 3 more times (= 4 open meshes in all), 9 ch, turn, sk next 2 open meshes <om>, sl st in next om, 3 ch, turn, dc in 2nd st of ch lp just made, work (dc, 1 ch) twice in each of next 2 sts, work (1 ch, dc in next st) 3 times, 1 ch, sk next st, hdc in next st, sc in next-to-last st of ch lp of prev sh, 3 ch, sk 4 sts of ch lp located below, work sc in each of next 2 sts, 10 ch, turn, sl st in 7th st of prev sh, turn, in each last 2 ch sts work sl st, 24 ch, sk next 7 sts, sl st in next st of sh, turn, rep from *** beg with 5th st of ch-24 lp until desired length is obtained; end with 5 ch (instead of 24) and fasten off (see black wedge). Now, WS facing, attach thread with sl st in first st of beg ch (see white wedge), ch 1 and work 17 ROWS following diagram. At end of row 17, fasten off (see black wedge). RS facing, attach thread with sl st in first st of beg ch (see white wedge) and work sl sts and ch sts across curlicues as shown in bold type; fasten off (see black wedge).

③ SCALLOP LACE

DEPTH:
3 1/4 inches.

MATERIALS:
DMC Special Cordonnet (Art. 151) crochet cotton no. 20, white (approximately 90 yds for a 12 1/4-inch length). Steel crochet hook US size 9 or SIZE FOR GAUGE.

GAUGE:
25 dc are 2" long and 1/4" high.

TO MAKE:
Beg with scallops, ch 8, work 1 shell <sh> (= dc, * 3 ch, dc, rep from * twice more) in first st of



yo 4 times, pull up lp in st of corresp ch lp, work **yo and draw thru 2 lps on hook** twice, cont with 5 partial tr (= * yo twice, pull up lp under corresp ch st, *yo and draw thru 2 lps on hook, rep from * once more, rep from * 4 more times, having 2 tr in same mesh <M> as bef, sk 2 M and having 3 tr in next M, yo and draw thru 6 lps on hook), rep from ** to ** twice, then, inserting hook in horizontal strand of st at top of 6-tr cluster, work 2 partial tr, yo and draw thru all 4 lps on hook, 5 ch, 3 partial tr, yo and draw thru all 4 lps on hook

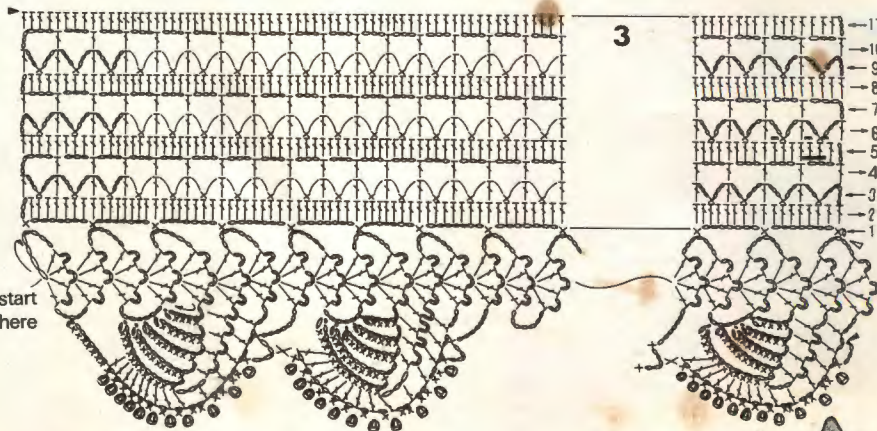
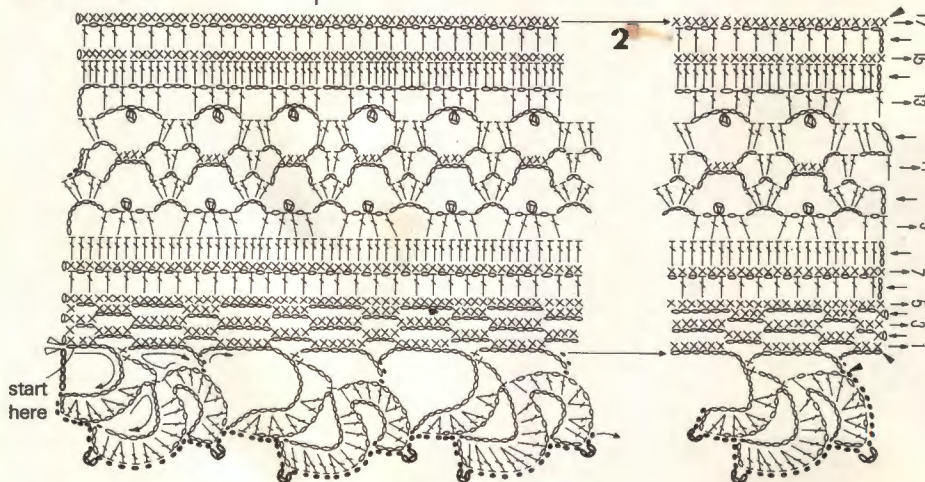
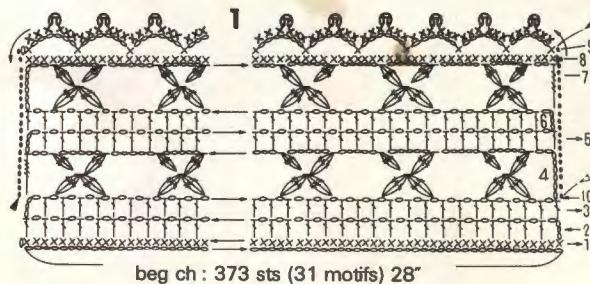

ch-8, 5 ch, turn, ** sh over sh, work (7 ch, turn, sh over sh) 3 times, 7 ch, sl st in edge ch-7 lp below (that is, in Tch), ch 1, turn, in ch-7 lp work 4 sc, 8 ch, turn, sl st in Tch, ch 1, turn, 6 sc in ch-8 lp, ch 9, turn, sl st in Tch, ch 1, turn, 8 sc in ch-9 lp, 10 ch, turn, sl st in Tch, ch 1, turn, 10

sc in ch-10 lp, 12 ch, turn, sl st in Tch, ch 1, turn, 12 sc in ch-12 lp, work (3 ch, dc in next ch lp) 4 times, 3 ch, sh over sh, 7 ch, turn, sh over sh, 3 ch, sk next ch lp, dc in next ch lp, work (2 ch, dc in next ch lp) 4 times, 2 ch, dc in next sc, work (1 ch, dc in next st) 8 times, 7 ch, sl st in ch

lp located bet first 2 sh, ch 1, turn, 7 sc in ch lp just made (bet next scallops, this ch lp will be replaced with sc worked in 2nd ch lp following sh); bet next 8 dc, work sc and picot (= 3 ch, sl st in top of last sc); in each of next 3 meshes work 2 sc, picot, then sc in next mesh, 4 ch, sc in

next mesh, 7 ch, rep from ** across; complete last scallop as shown on diagram, fasten off (see black wedge). RS facing, attach thread with sl st in Tch bet last 2 sh (see white wedge), ch 1 and work 11 ROWS following diagram. At end of row 11, fasten off (see black wedge).



3

2

1

NAPKIN KEEPER

By Chantal Chevallier

SIZE:
The envelope, not including flap, measures 7 1/2 by 3 1/4 inches. Flap is 2 3/4" deep.

MATERIALS:
Crochet cotton no. 30, ecru, about 165 yds. Steel crochet hook US size 11 or **SIZE FOR GAUGE.**

GAUGE:
Three motifs and 7 rows measure 1 1/2" on each side.

TO MAKE:
Ch 91 + 3 ch to turn. **ROW 1:** Tr in 7th st from hook, 4 ch, sl st in same st as last tr, *** 4 ch, 2-tr cluster <cl> (= ** yo twice, pull up lp in same st as bef, * yo and draw thru 2 lps on hook, rep from * once more, sk 5 sts, rep from ** once more, yo and draw thru all 3 lps on hook), 4 ch, sl st in same st as last tr, rep from *** 13 more times, end with 4 ch, cluster 1 tr and 1 dc in same way as you worked 2-tr cl but insert hook for tr in same st as last tr, sk 2 sts and insert hook for dc in next st; turn. **ROWS 2-41:** Beg even-numbered rows with sl st in first st, end them with sl st in last st below. Beg odd-numbered rows with 7 ch,

end them by clustering 1 tr with 1 quadruple triple crochet (= yo 5 times, pull up lp in sl st, complete in same way as tr). Rep rows 1 and 2 for pat. At end of row 41, turn and work 1 row **FLAP EDGING** across row 41 as shown, making ch-6 lps. Fasten off (see black wedge). Now attach thread with sl st in beg ch (see white wedge) and work 1 row **OPENING EDGING** across beg ch as shown. Fasten off (see black wedge).

FINISHING: Fold piece referring to measurements on diagram of completed envelope and work edgings A and B on each side as shown. Inserting hook thru both thicknesses across envelope, cont edging B across side edge and front edge of flap. Work edging A across rem flap edge and cont across envelope.

GAUGE: 3 motifs and 7 rows measure 1 5/8 inch square

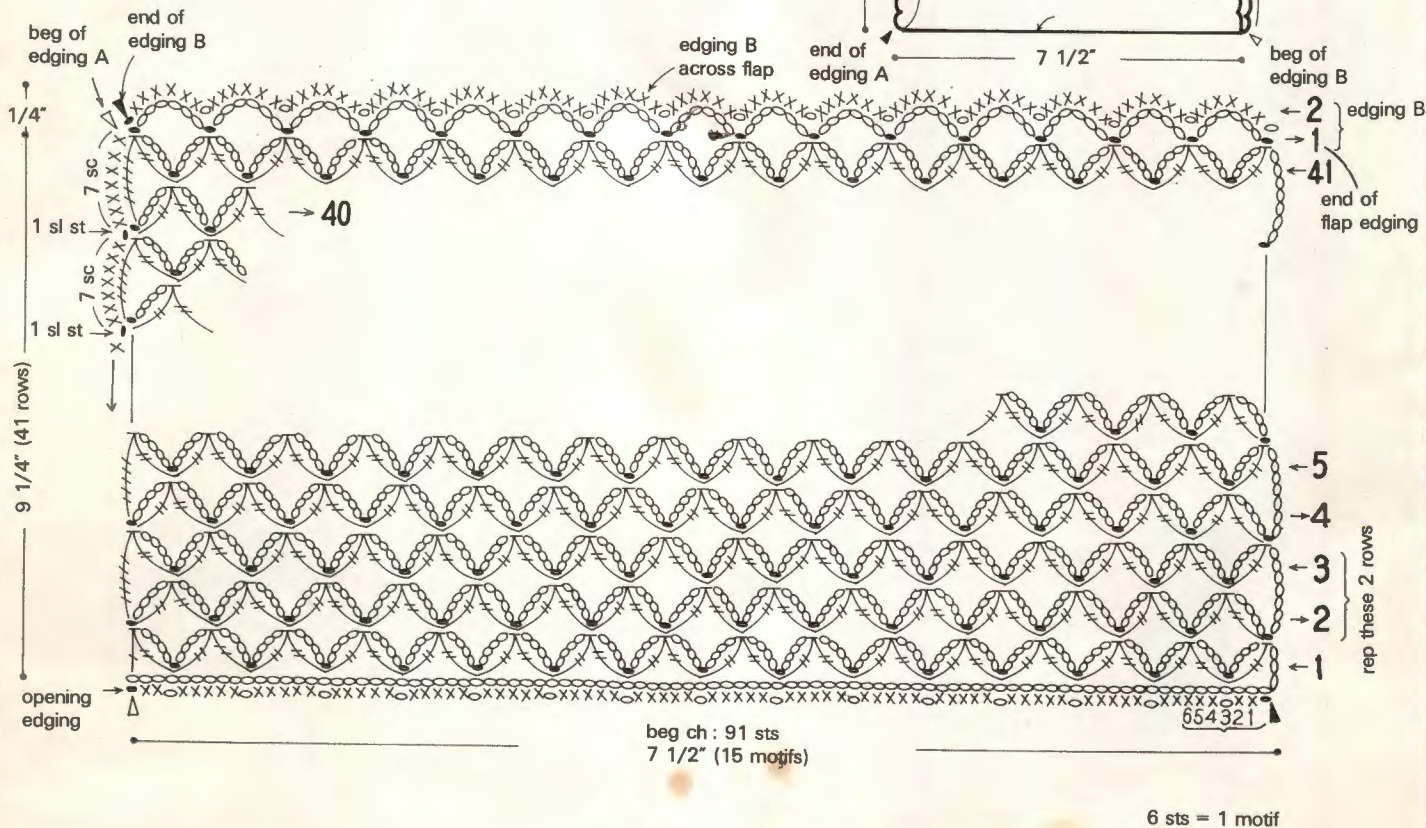
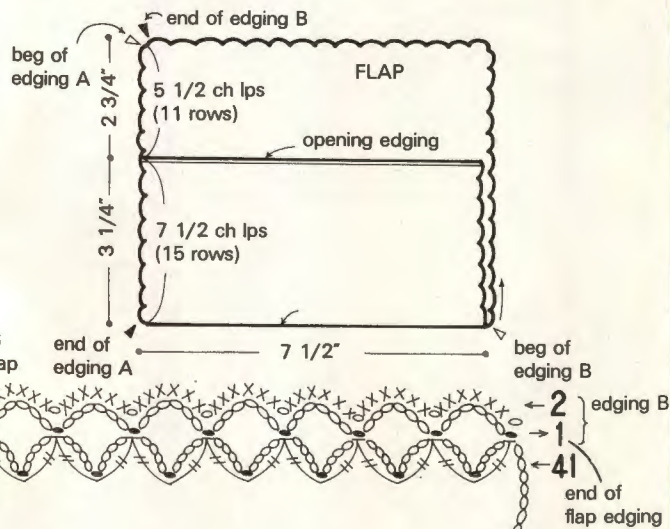



GREEN and GOLD

By Glendola Hodges

SIZE:
13 1/2" in diameter.

MATERIALS:
Shiny quality crochet cotton (or fil d'Ecosse) no. 10 (you can also use pearl crochet cotton no. 5), about 40 yds green and about 115 yds yellow. Steel crochet hook US size 6 (size 4 if you tend to work very tightly) or **SIZE FOR GAUGE.**

GAUGE:
First 3 rnds measure 1 3/4" in diameter.

TO MAKE:
With yellow, ch 8 and join with sl st to form ring. **RND 1:** In ring work (dc, 2 ch) 12 times; up to rnd 2 and also on rnds 10-14, close each rnd with sl st in top of ch-3 (= first dc throughout). **RND 2:** Dc in each dc and 3 dc in each ch-2 lp = 48 dc in all. **RND 3:** Ch 1, beg in same st as closing sl st work (sc in dc, 3 ch, sk 1 st) 24 times; close with sl st in first sc. Cut yellow. **RND 4:** RS facing, attach green with sl st in any ch-3 lp, then, in each ch lp around, work 4-dc cl (same cluster principle as 3-dc cl according to how-to) and 3 ch; up to rnd 7, close each rnd with

sl st in top of first cl and cont with sl st in first ch lp. **RNDS 5-21:** Insert hook in ch lps and work following diagram. On rnd 8, last 3 ch sts = dc in top of first cl. On rnd 9, cut green (see black wedge). For rnd 10, RS facing, attach yellow with sl st in ch-7 lp (see white wedge) and cont in yellow. On rnd 15, last 2 ch sts = hdc in 3rd st of ch-6. On rnd 16, last 3 ch sts = dc in first sc.

On rnds 17-20, last 4 ch sts = tr in first sc. On rnd 21, close same as on rnd 3. Fasten off (see black wedge).

GAUGE: rnds 1-3 are 1 3/4" across

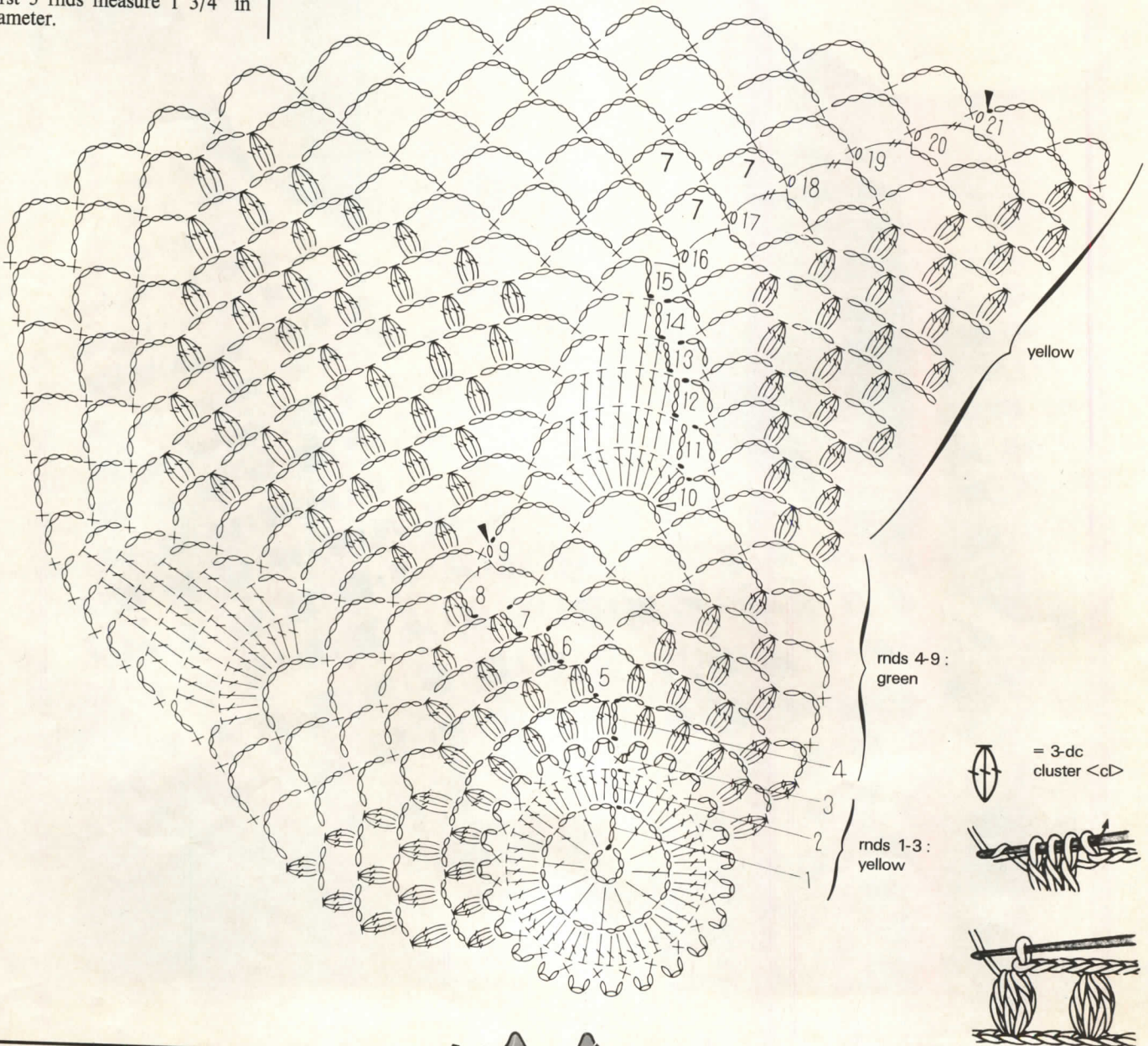

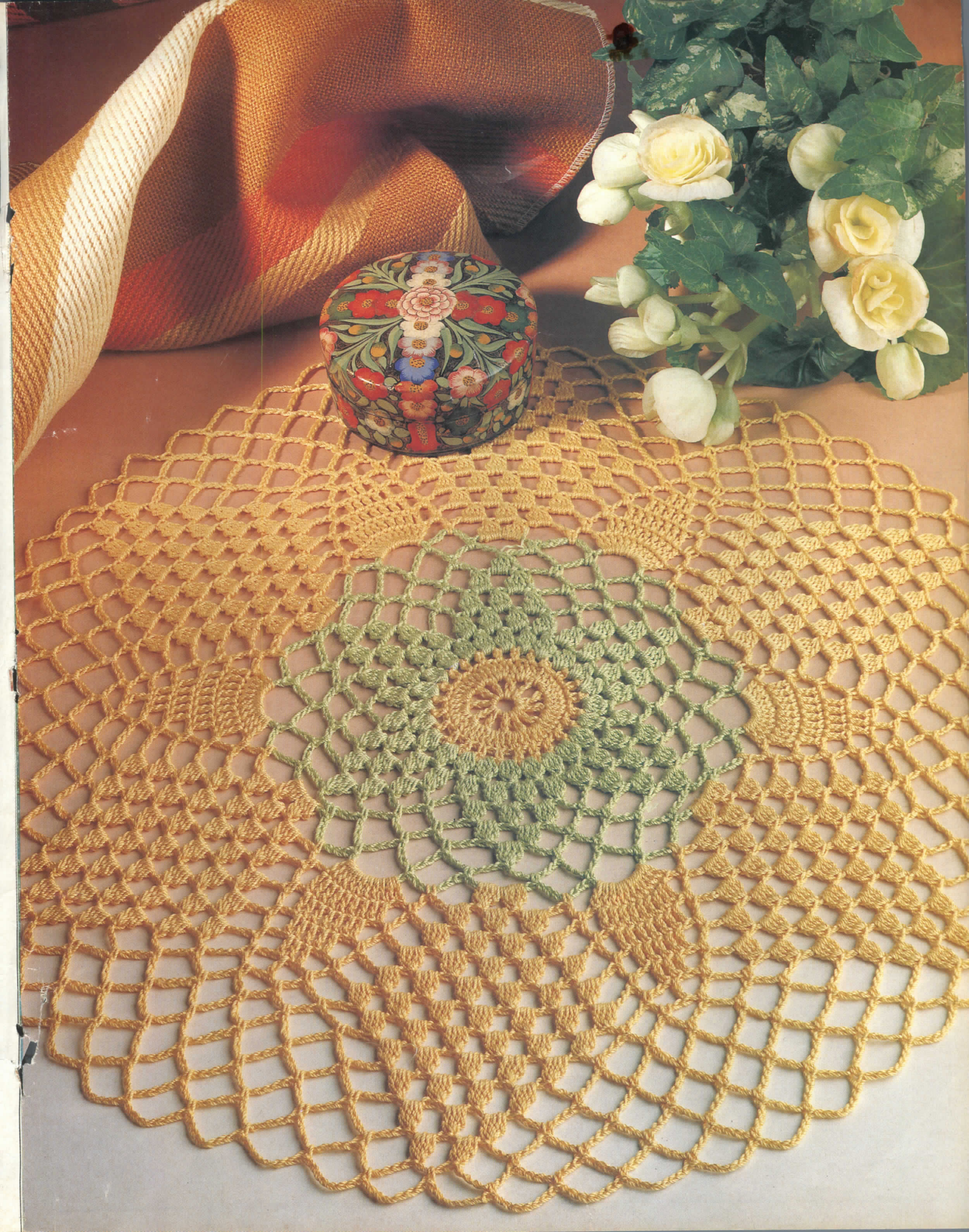

VENUS IN VIEW

By Glendola Hodges

SIZE:
15 3/4" in diameter.

MATERIALS:
Shiny quality crochet cotton (or fil d'Ecosse) no. 20, ecru, about 160 yds. Steel crochet hook US size 11 (size 9 if you tend to work tightly) or SIZE FOR GAUGE.

GAUGE:
First 3 rounds measure 2" in diameter.

TO MAKE:
Ch 12 and join with sl st to form ring. RND 1: In ring work 32 tr; close with sl st in top of ch-4 (= first tr). RND 2: Work (dc in tr, 1 ch) 32 times; up to rnd 7, close each rnd with sl st in top of ch-3 (= first dc throughout) and cont with sl st in first ch-1 lp. RND 3-7: Insert hook in ch lps and work following diagram. RND 8: Ch 1, work ** sc in ch-1 lp bet 2 dc worked in same

ch lp below, 4 ch, dc in next ch lp, * 1 ch, dc in next ch-1 lp, rep from * 5 more times, 4 ch, rep from ** around; close with sl st in first sc, cont with sl st in each of next 3 ch sts to beg new rnd in 3rd st of ch-4. RND 9-29: Work following diagram, close each rnd with sl st. Insert hook in corresp ch lps except on rnd 21, where 1 sc is worked in each of 3 center sts of ch-15 lps. At end of rnd 29, fasten off (see black wedge).

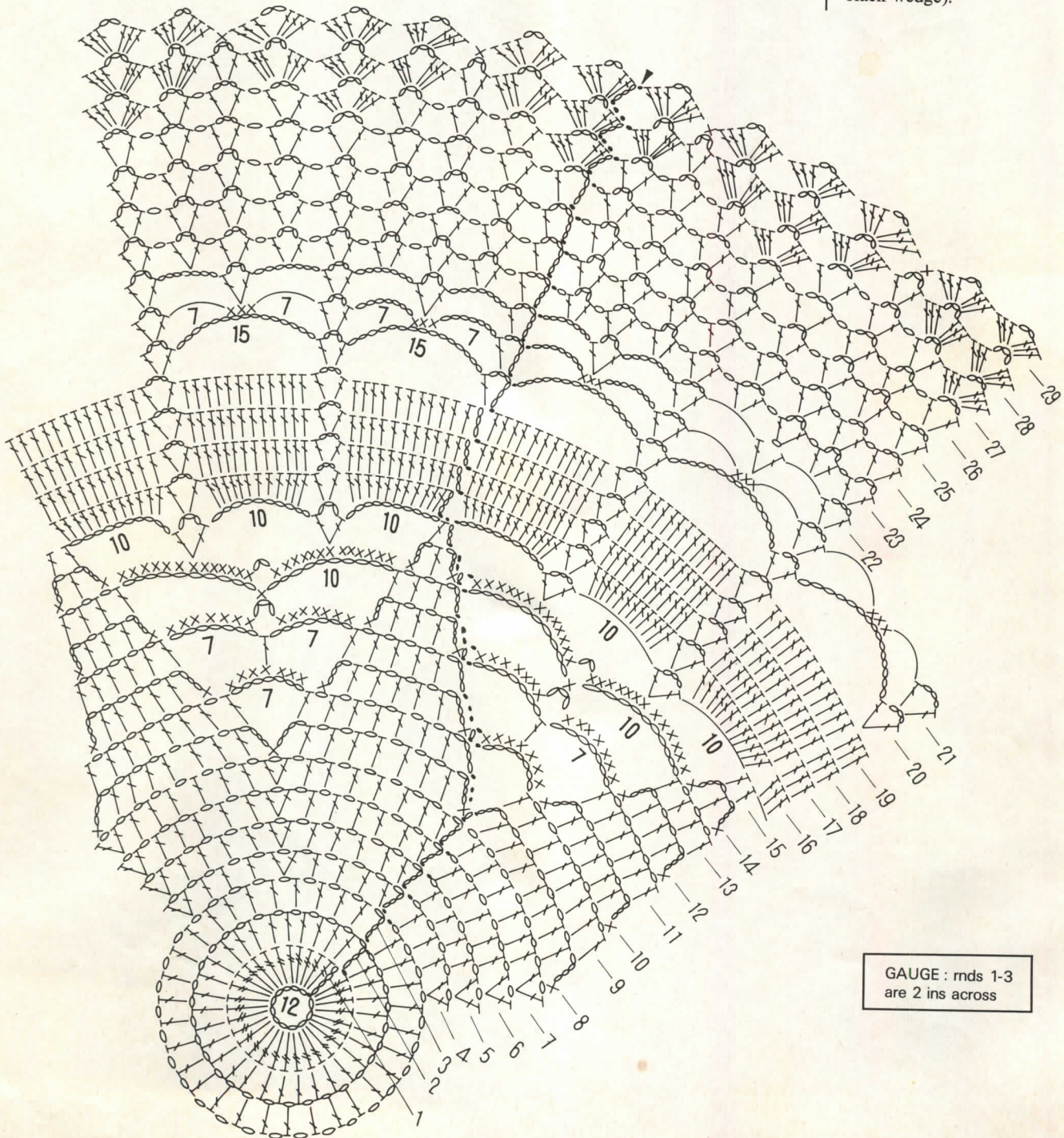

GAUGE: rnds 1-3
are 2 ins across



GREAT MOMENT

By Claudette Sguazzini

SIZE:
54 inches across, measured from tip to opposite tip.

MATERIALS:
Mercerized bedspread-weight crochet cotton no. 5, ecru, about 2,525 yds (that is, 455 grams or 16 1/4 oz). Steel crochet hook

US size 4 or SIZE FOR GAUGE.

GAUGE:
First 3 rnds measure 1 3/4" in diameter. TO SAVE TIME, TAKE TIME TO CHECK GAUGE.

TO MAKE:
Ch 12 and join with sl st to form ring. RND 1: Ch 1, in ring work 24 sc; close first 2 rnds with sl st in first sc. RND 2: Ch 1, work sc in each sc around. RND 3: Work (dc in sc, 5 ch, sk 1 st) 12

times; on rnds 3-32 and 46-59, close each rnd with sl st in top of ch-3 (= first dc throughout). RND 4: Sc in first ch lp, then work 6 dc in each ch lp around. RND 5: Work (dc in each of 12 dc, 3 ch) 6 times. RND 6: Sl st to beg rnd in 2nd dc of first dc grp, work (10 dc, 2 ch, dc + 3 ch + dc in ch lp, 2 ch, sk first dc of next dc grp) 6 times. RNDs 7-59: Up to rnd 10, cont with sl st at beg of each rnd to start new rnd in 2nd dc of first dc grp and

work following diagram. On rnd 24, beg 6 cobweb motifs with sc in each of 5 center sts of ch-15 lps. As of rnd 27, work 1 picot after each sc thus: 3 ch, sl st in top of last sc. On rnds 33-45, last 3 ch sts = dc in first sc. At end of rnd 59, fasten off (see black wedge). ROWS 60-88: RS facing, attach thread with sl st in 9th ch lp to right of dc grp (see white wedge) and complete point work-

4 = insert hook in st(s) to which symbol points

⊥ = 1 dtr

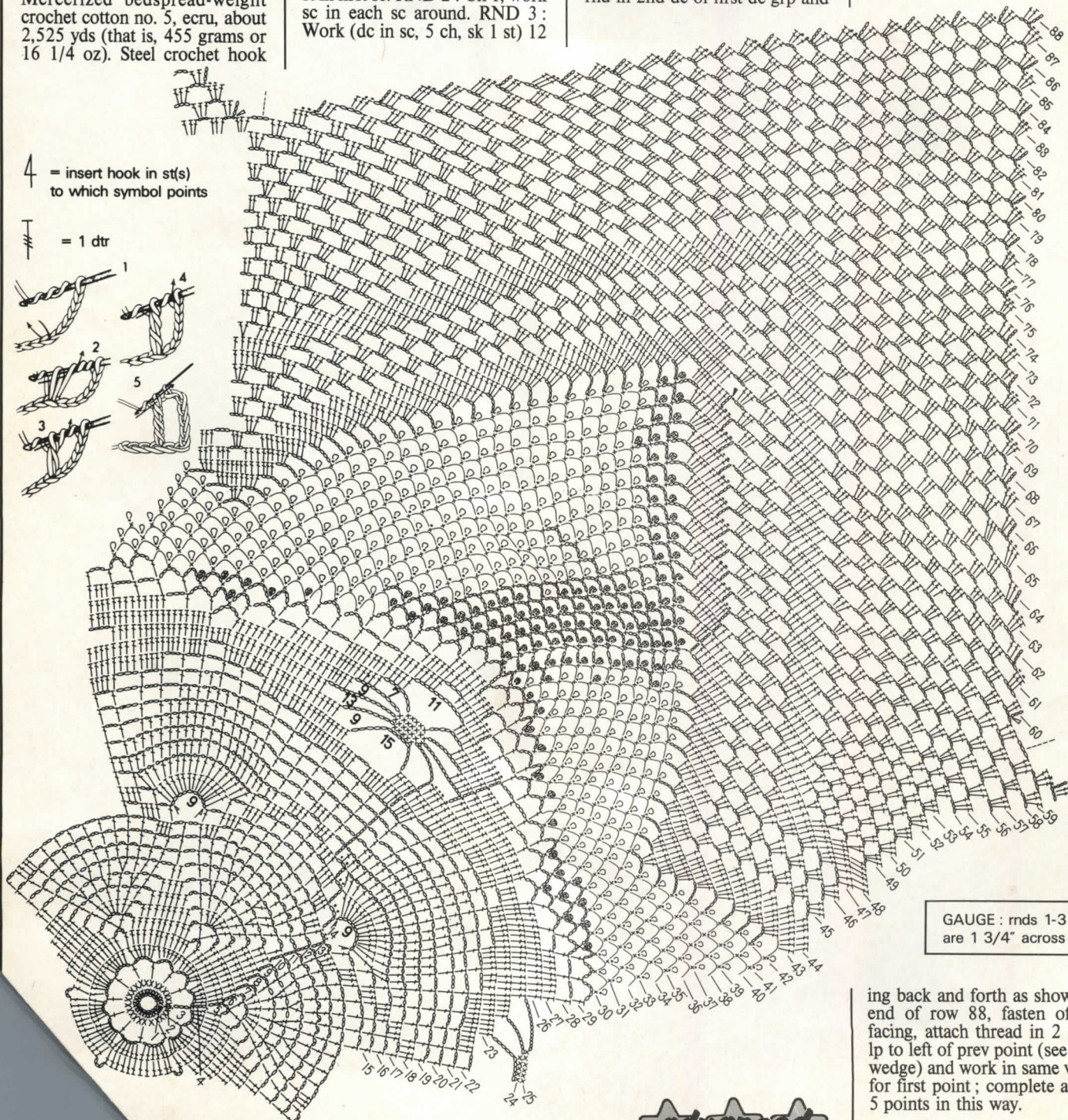
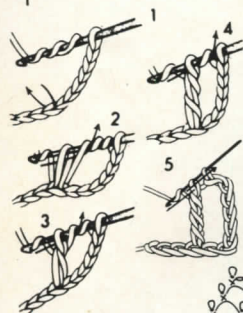

GAUGE: rnds 1-3 are 1 3/4" across

ing back and forth as shown. At end of row 88, fasten off. RS facing, attach thread in 2nd ch lp to left of prev point (see white wedge) and work in same way as for first point; complete all rem 5 points in this way.



21

WHITE LOTUS

By Claudette Sguazzini

SIZE:
18" in diameter.

MATERIALS:
Pearl crochet cotton no. 8, white, about 620 yds. Steel crochet hook US size 11 or SIZE FOR GAUGE.

GAUGE:
First 5 rnds are 1 5/8" in diameter.

TO MAKE:
Form loop with end of thread.

RND 1: Ch 1, in lp work 8 sc; close with sl st in first sc. **RND 2:** 2 dc in each sc around = 16 dc in all; as of this rnd, close each rnd with sl st in top of ch-3 (= first dc throughout). **RND 3:** Work (dc in dc, 5 ch, sk 1 dc) 8 times. **RND 4:** Work (2 dc in dc, 3 ch, sc in 3rd st of ch-5 lp, 3 ch) 8 times. **RNDS 5-39:**

Insert hook in dc or in corresp ch sts and work following diagram. At beg of rnd 20, work 4 sl sts to start rnd in 2nd of first 2 dc worked in same st, and, bet 4-dc grps always worked across 2-dc incs on rnd 19, ch 5 and rep (sk 4 sts, dc in next st, 5 ch) 3 times. On rnds 31, 32 and 34, dc incs are shown in bold type. At end of rnd 39, fasten off (see black wedge).

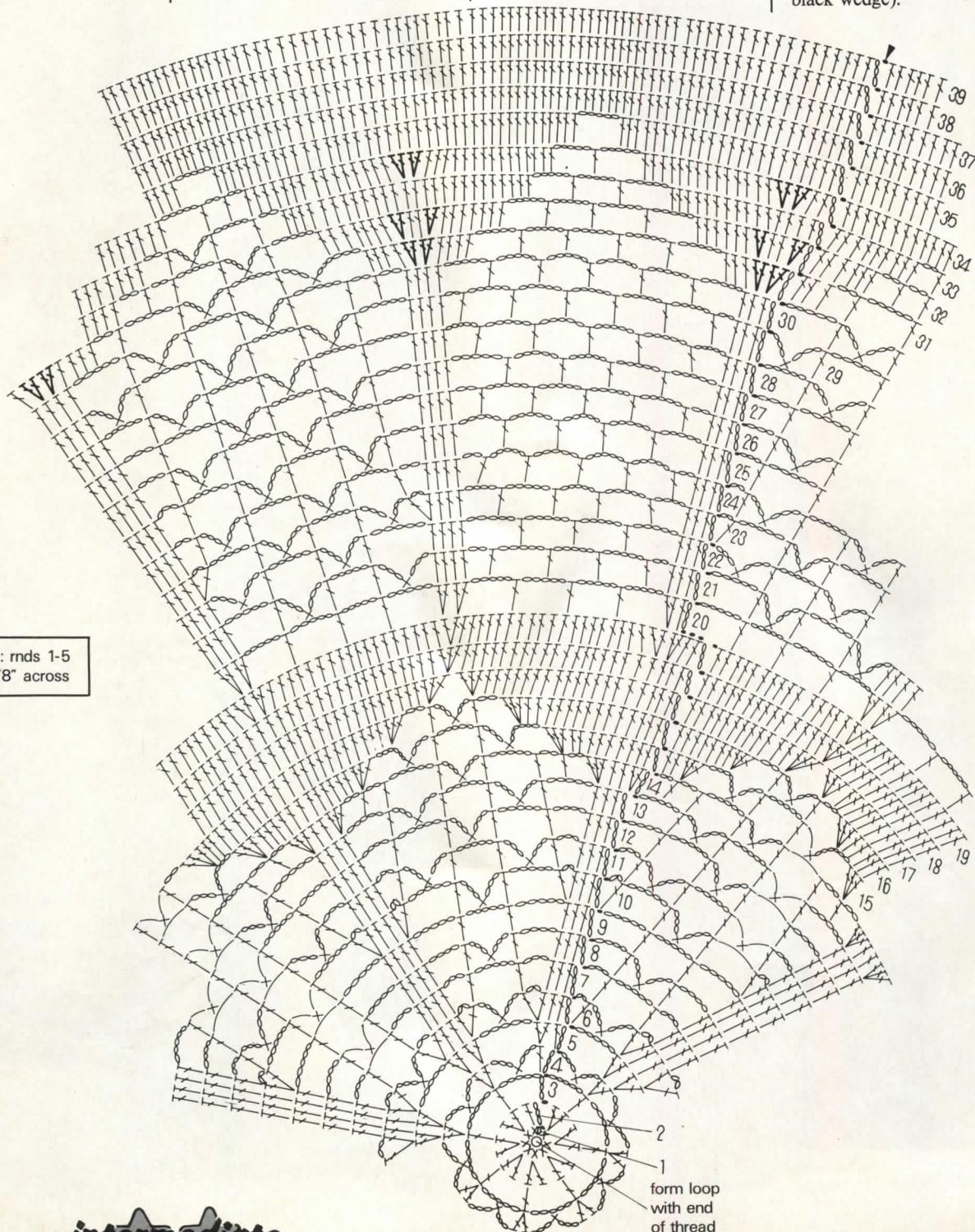

GAUGE: rnds 1-5 are 1 5/8" across



PROPER PROPOSAL

By Glendola Hodges

SIZE:
About 19 by 16 1/2 inches.

MATERIALS:
Shiny quality crochet cotton (or fil d'Ecosse) no. 20, ecru, about 285 yds. Steel crochet hook US size 6 (size 4 if you tend to work very tightly) or **SIZE FOR GAUGE.**

GAUGE:
First 4 rnds measure 3 1/4 by 1 3/4 inches.

TO MAKE:
Beg at center, ch 12. **RND 1:** 3 ch (= first dc throughout), 2 dc in 4th st from hook, dc in each of next 10 sts, 5 dc in next (= last) st, cont on other side of beg ch with dc in each of next 10 sts, 2 dc in next st; up to rnd 4, close each rnd with sl st in top of ch-3. **RNDS 2-4:** Dc all around, inc as shown = 90 dc in all on rnd 4. **RND 5:** Ch 1, beg in same st as closing sl st work (sc, 3 ch, sk 1 st) 45 times; on rnds 58, last 2 ch sts = hdc worked in first sc. **RNDS 6-30:** Insert hook in ch lps and in top of dc, work following diagram. As of rnd 9, close each rnd with sl st except rnd 29, where last 3 ch sts = dc in first sc. **RND 31:** Sl st in first ch lp, then work * 14 dc (that is, 7 in each of 2 ch lps), picot <p> (= 5 ch, sl st in top of last dc), rep from * around. **RND 32:** Cont with sl sts up to next p, then work * shell in p, dc + 5 ch + dc bet two 7-dc grps, rep from * around; close with sl st in top of ch-3. Fasten off (see black wedge).

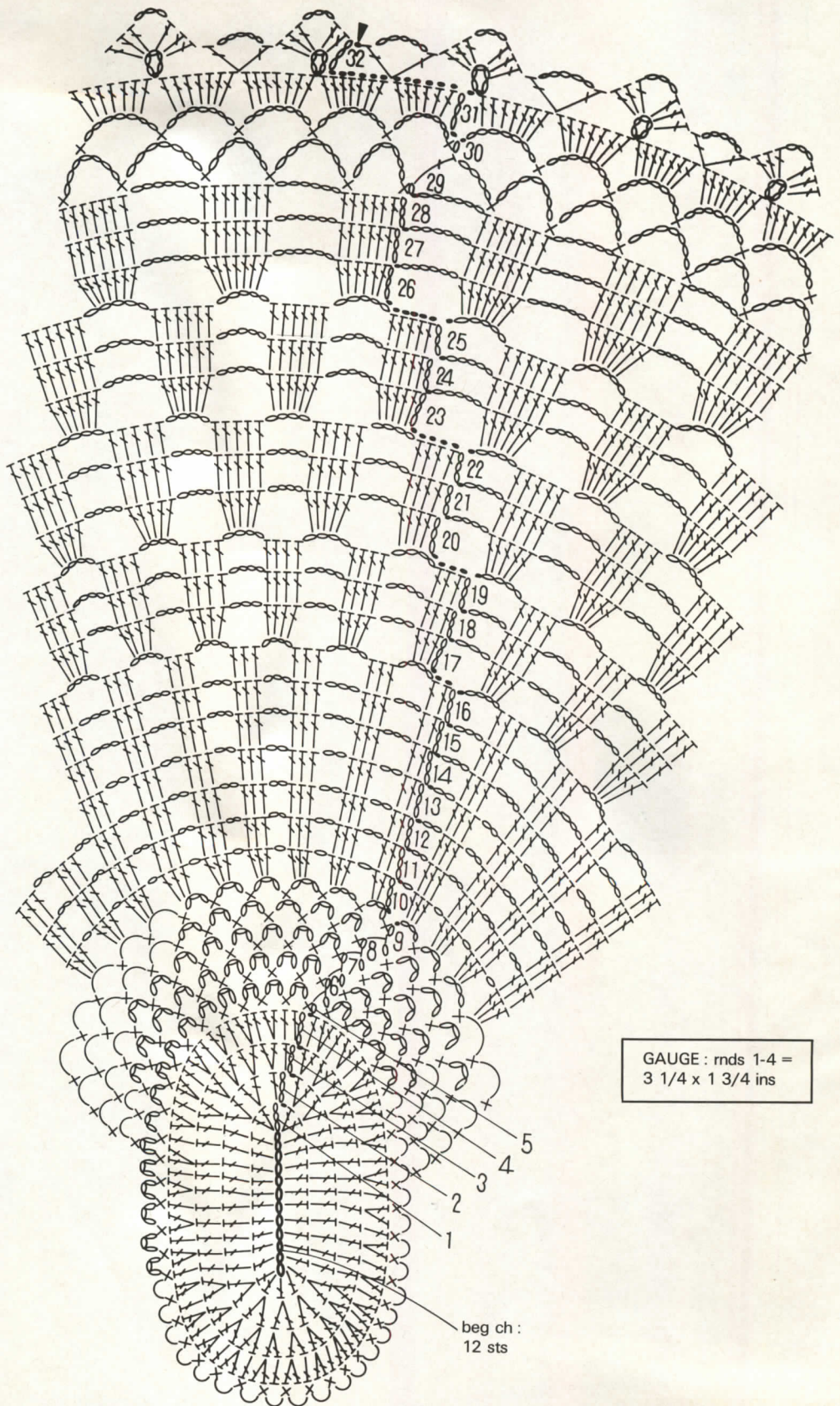

GAUGE: rnds 1-4 =
3 1/4 x 1 3/4 ins



ARTISTIC BOOK MARK

By Chantal Chevallier

SIZE:
2 1/4" wide and 13 3/4" long, not counting tassel.

MATERIALS:
Pearl crochet cotton no. 5, white, about 80 yds. Steel crochet hook US size 7 or **SIZE FOR GAUGE.**



= 4-dc cluster <c> : ** yo, pull up lp in mesh, yo and draw thru 2 lps on hook, rep from ** 3 more times, yo and draw thru all 5 lps on hook

GAUGE:
6 meshes are 2" wide; 4 rows are 1 1/4" high.

TO MAKE:
Beg at tip, ch 7 + 3 to turn.
ROW 1: Dc in 4th st from hook,

dc in each of next 5 sts, 2 dc in last st; ch 6, turn. **ROW 2:** Beg in 3rd st from hook, work sc, hdc, 11 dc, drop thread. Attach new thread with sl st in top of ch-3 below, ch 4, fasten off (= auxiliary ch made), then pick up dropped thread and work 2 dc,

hdc and sc in auxiliary ch plus 1 more sc in last ch st as shown; ch 3, turn. **ROW 3:** Beg with next-to-last sc, work 18 dc; ch 5, turn. **ROWS 4-45:** Work following diagram and 4-dc cl symbol. **FINISHING:** At end of row 45, ch 1 and work crab stitch (= sc worked from left to right) all around (at tip ch 5); close with sl st in first crab st. Complete tassel as shown and tie into ch-5 lp at tip.

CRAB STITCH

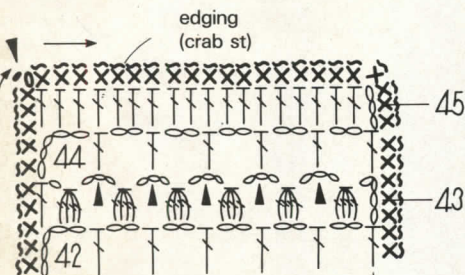
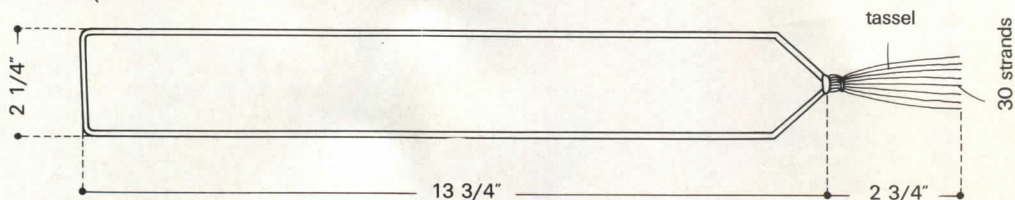
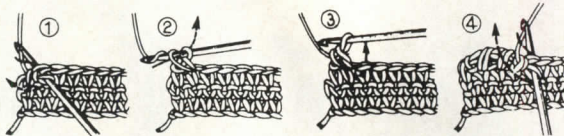

GAUGE: 6 meshes = 2"
4 rows = 1 1/4" high

rows 11-41:
rep rows 9 and 10

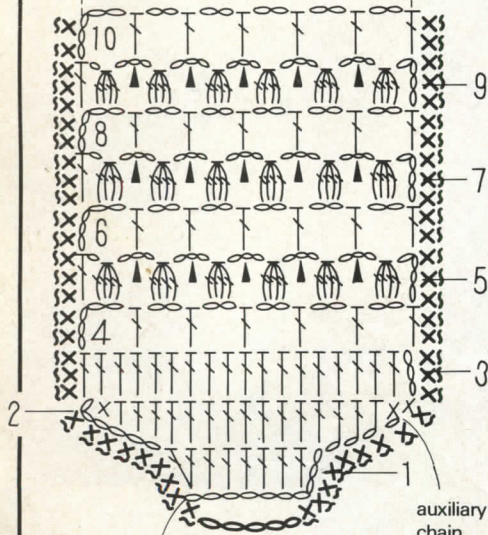

beg ch : 7 sts
▲ insert hook in st to which wedge points
▼ fasten off



MAGIC CROCHET PUBLICATIONS

COLLECT BACK ISSUE COPIES



32 \$ 4.00



33 \$ 4.00



34 \$ 4.00



37 \$ 4.00



42 \$ 4.00



43 \$ 4.00

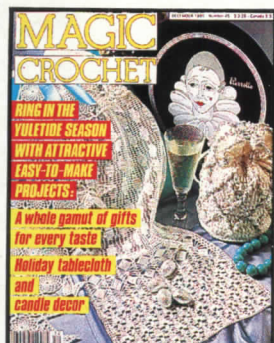

45 \$ 4.00



48 \$ 4.00



49 \$ 4.00



50 \$ 4.00



53 \$ 4.00



54 \$ 4.00



55 \$ 4.00



56 \$ 4.00

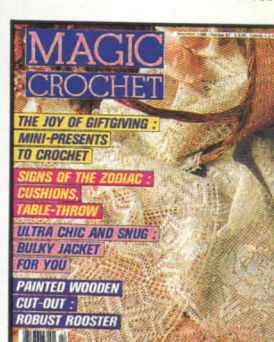

57 \$ 4.00



58 \$ 4.00



59 \$ 4.00



60 \$ 4.00



61 \$ 4.00



62 \$ 4.00



63 \$ 4.00



64 \$ 4.00



65 \$ 4.00



66 \$ 4.00



71 \$ 4.00

A MAGIC SPECIAL : FILMSTRIP OF HOW-TOS



MULTI-LOOP RINGS 24

Every crocheter has her own little ways. Some like to start their round mats with a chain-stitch ring. Others prefer forming a loop with the end of thread, working the first round into the loop and then pulling the tail to close the opening. Both methods are equally fine. And yet, forming a loop with the

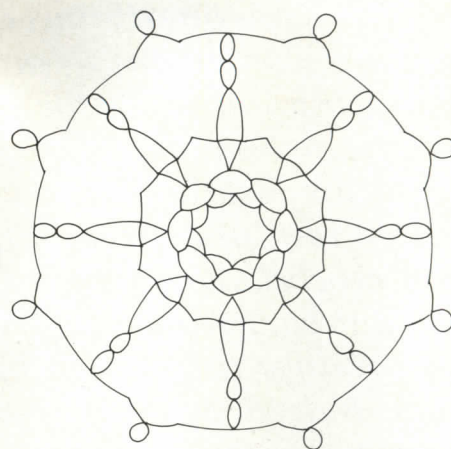

17 3/4"

how to start rnd 1

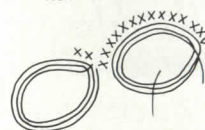

with end of thread form 3 loops 5/8" in diameter, ch 1 and work 13 sc in loop thus formed

GAUGE : rnds 1-2 are 3 1/4" across

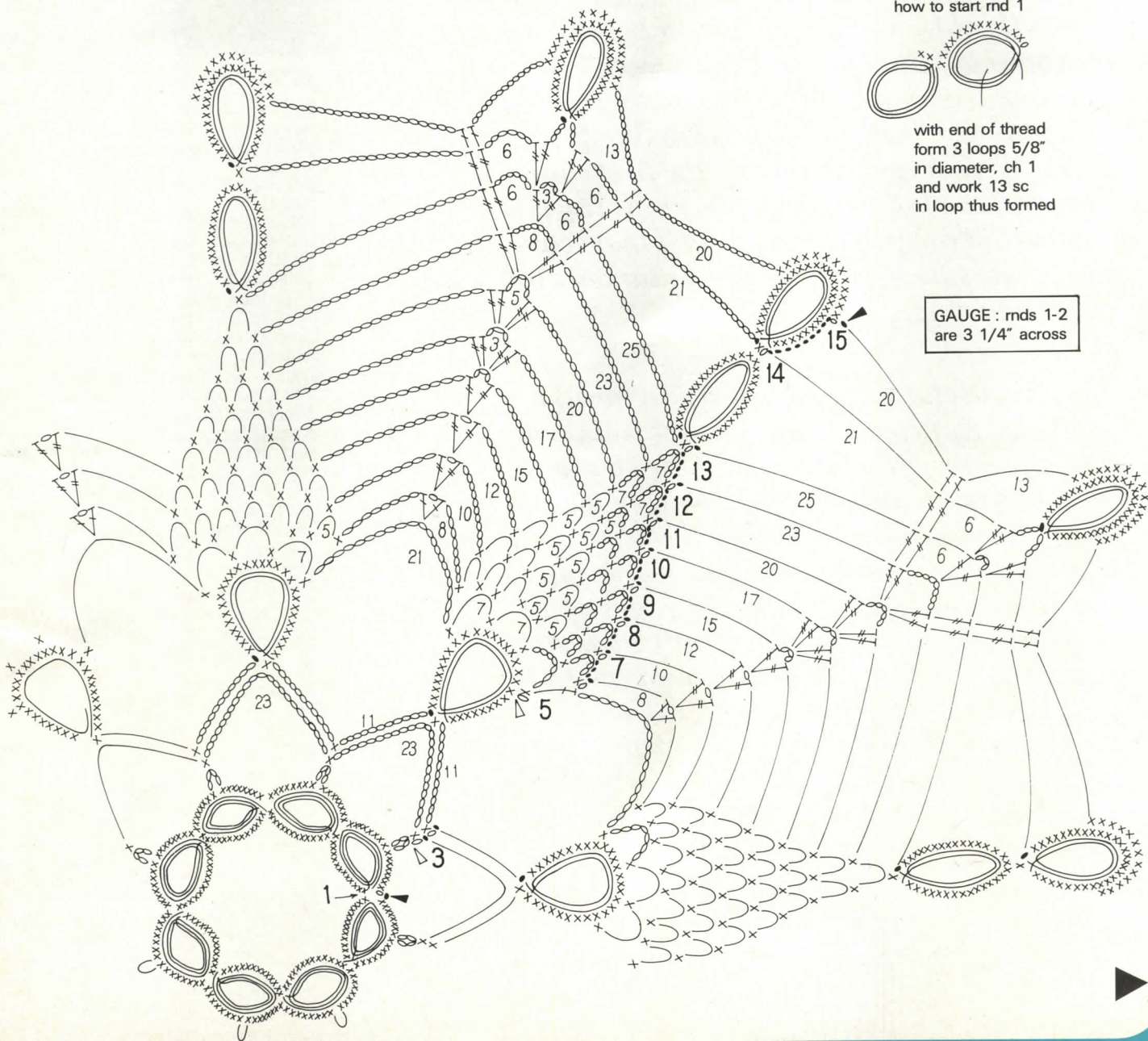

A MAGIC SPECIAL : FILMSTRIP OF HOW-TOS

thread end has one distinct advantage: once you have worked one — or even several — rounds into the loop, the size of ring thus formed can be easily adjusted. To lie perfectly flat, for instance, or to even out irregularities resulting from different ways of doing crochet. As a matter of fact, thread tension can vary from one person to another and produce a considerable difference in gauge. Indeed, working tightly or loosely is a very individual thing.

If this way of starting a mat is new to you, here is a golden opportunity to improve your crocheting skills. For our "Raindrops" mat, wind the thread several times to form a multi-loop. Next, pick up your hook and work the first ring: complete the first round and pull the tail to tighten the ring. The tail will also show you where to start the second round. Be sure to keep the same diameter for each new ring.

This is a useful method to have in mind for starting any project worked in the round, especially when you have opted for changing the thread size and want to be certain the end result is what you hoped for. Let's suppose you are looking for a mat to cover a fairly flat lampshade and want the edges of the mat hanging down like so many petals. And now let's suppose you have found the right beautiful pattern but its center is too solid for inserting wire and socket. With the Multi-loop Method all you need to do is complete one right-size ring with the thread used for the project, work a 2nd, 3rd and 4th round directly over it, then adjust the original opening to size if necessary. Once you get the hang of it, you'll say why didn't you think of this before?

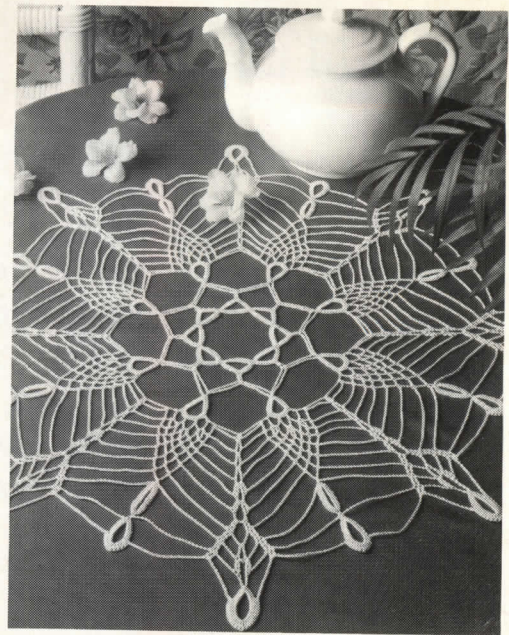

Original design by Jackie Kilby

SIZE : 17 3/4" in diameter.

MATERIALS : Shiny crochet cotton (or fil d'Ecosse) no. 20, ecru, about 165 yds. Steel crochet hook US size 9 (size 7 if you tend to work very tightly) or **SIZE FOR GAUGE.**

GAUGE : First 2 rnds (that is, 8 joined rings) measure 3 1/4" in diameter.

TO MAKE : RNDs 1-4 : See diagram and photos 1 through 10. RND 5 : ** sc in 9th sc of a ring, * 7 ch, sk 3 sts, sc in next st, rep from * twice more, 21 ch, rep from ** around ; last ch lp = 18 ch and dc in first sc. RNDs 6-15 : On rnd 6, work sc in 3rd ch st on each side of ch-21 lps and in ch-5 lps, work dc in center st of ch-21 lps. Now work following diagram. As of rnd 6, close each rnd same as on rnd 2 and cont with sl sts to center of first ch lp. Make sure all rings are the same size and work 31 sc in rings on rnd 13 ; 29 sc in rings on rnd 14 which are located above a ring ; and 30 sc in those at center of shells ; close all these rings with sl st in first sc bef working next 3 ch. On rnd 15, work sc in back strand only of ring sc ; close with sl st in first sc. Fasten off (see black wedge).

RAINDROPS IN THE WATER

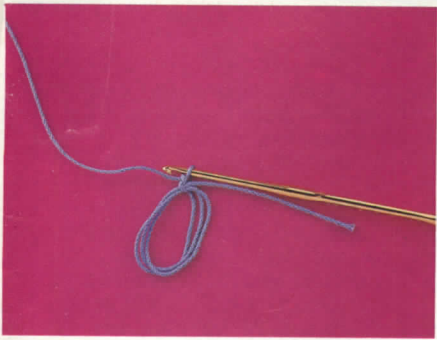

1- RND 1 : Hold the triple loop between thumb and index finger of left hand, insert hook into loop and work 1 ch over all 3 strands at the same time.

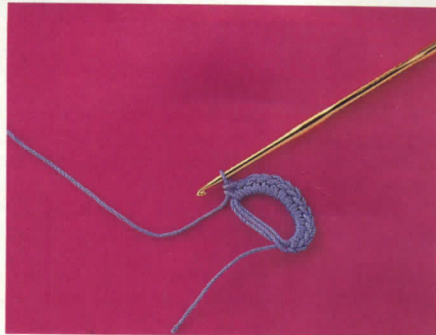

2- In loop work 13 sc to form first half of ring.

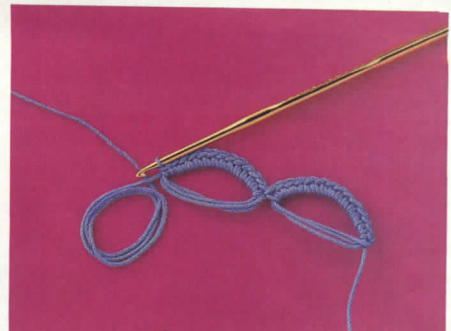

3- For each new ring, with ball thread form triple loop same size in diameter as first ring by wrapping thread from right to left and from top toward bottom.

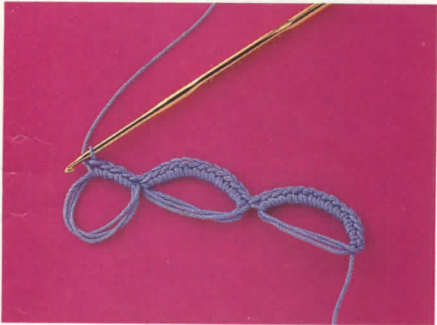

4- Hold each triple loop as close as possible to last sc of previous ring and work 13 sc in each ring.



5- After completing first rnd (= 8 rings in all), remove hook from lp and form a circle placing the sc half on inside and the strand half on outside of circle.



6- RND 2 : Pick up dropped lp and work sc over strand half of rings.

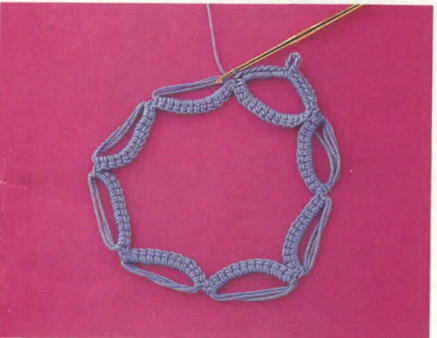

7- In each ring work 8 sc, 4 ch and 8 sc; close rnd with sl st in first sc. Cut thread.



8- RND 4 : Work sc in sc on rnd 3, 11 ch, then sc in ch-23 lp.



9- With ball thread form 2 loops same size in diameter as loops on first round and hold them as closely as possible to last sc.



10- After working 28 sc in ring, join this ring with sl st to top of sc worked in ch-23 lp.

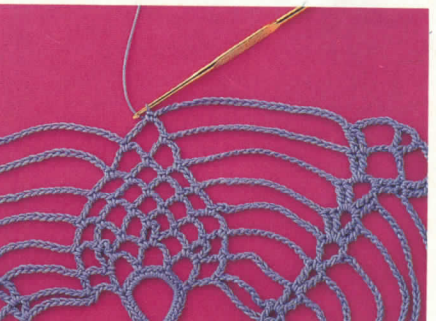

11- RND 13 : Work sc in ch-7 lp (tip of pineapple).



12- Form 2 loops same as on rnd 4, work 31 sc in ring and join this ring in same way as on rnd 4.

25

EASY LIVING

By Glendola Hodges

SIZE:
Approximately 77 1/2" wide and 90" long.

MATERIALS:
Mercerized bedspread crochet cotton (or fil d'Ecosse) no. 10, ecru, about 6,600 yds. Steel crochet hook US size 4 or **SIZE FOR GAUGE.**

GAUGE:
4" square = 10 meshes and 11 rows. **TO SAVE TIME, TAKE TIME TO CHECK GAUGE.**

TO MAKE:
Beg at one width end, ch 592 + 5 to turn (3 ch count as first dc and 2 ch form first open mesh or om). **ROWS 1-6:** Dc in 9th st from hook, * 2 ch, sk 2 sts, dc in next st, rep from * across = 197 om in all; ch 5, turn each row. **ROW 7:** 10 om, * 1 solid mesh <sm> (= 2 dc in ch-2 lp, dc in next dc), 7 om, rep from * 21 more times, end with 1 sm, 10 om. **ROW 8:** 9 sm, * 1 sm, 11 ch, sk 2 sts, dc in next st, 1

sm, 5 om, 1 sm, 1 om, 1 sm, 5 om, rep from * 10 more times, end with sm, 11 ch, sk 2 sts, dc in next st, 1 sm, 9 om. **ROWS 9-22:** Alternate diamonds as per diagram, work sc of cobweb motifs in ch lps and in corresp sc of row below. Rep rows 7-22 until you obtain 15 cobwebs and 15 diamonds = 246 rows in all. Work row 247 in same way as row 7, then work 6 rows om = 253 rows in all. At end of row 253, fasten off.

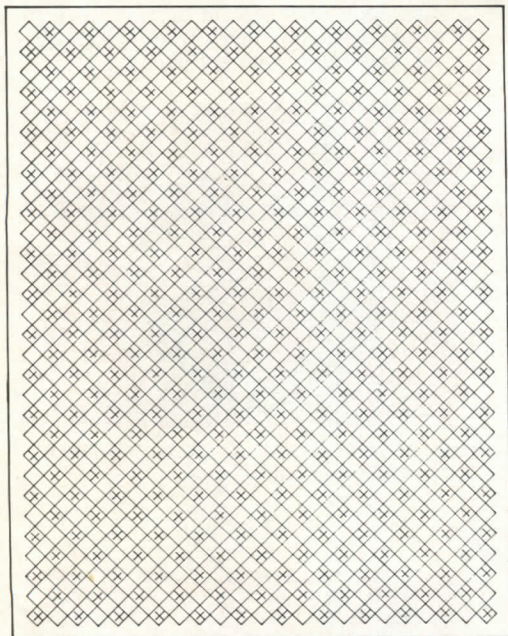

◇ = cobweb motif

23 diamonds + 13 meshes
197 meshes in all

GAUGE: 4" square =
10 meshes x 11 rows

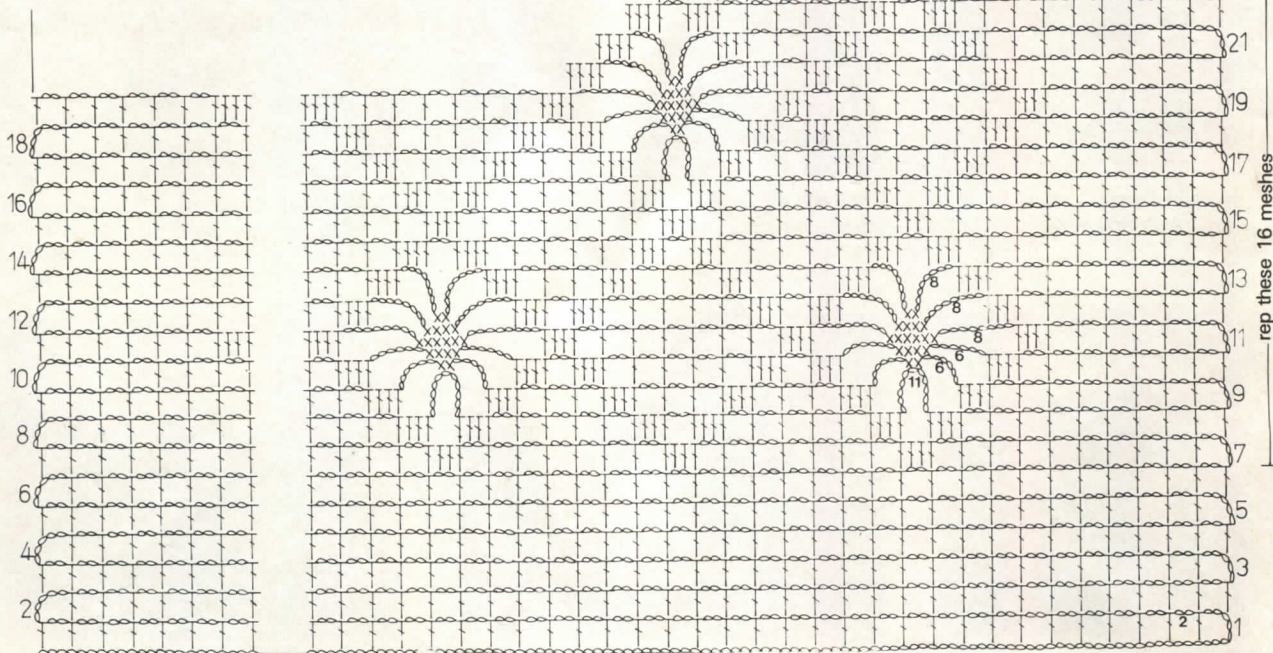
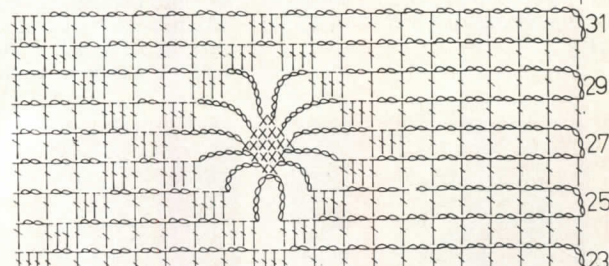
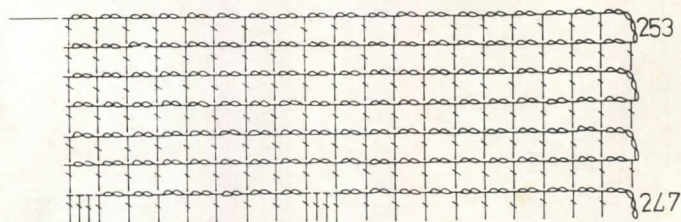

rep these 16 rows

beg ch: 592 sts (197 meshes) about 77 1/2"



REGENCY



By Chantal Chevallier

SIZE :

Refer to individual diagrams.

MATERIALS :

Cordonnet crochet cotton no. 20, ecru, about 525 yds. Steel crochet hooks US size 9 (for placemat) and 11 (for coaster and napkin envelope) or **SIZE FOR GAUGE.**

GAUGE :

See respective diagram.

TO MAKE

PLACEMAT : Ch 43 + 3 to turn (= first dc throughout). **ROW 1 :** Dc in 5th st from hook and each st across; ch 9 (6 ch for base of 2-mesh inc and 3 ch to replace first dc on row 2), turn. **ROW 2 :** Beg in 5th st from hook, work 6 dc (= 2 solid meshes or sm), then * 2 ch, sk 2 sts, dc in next st, rep from * 13 more times = 14 open meshes or om, then inc 2 sm with 6 tr (work first tr in same st as last dc, each following tr in first cross strand of prev tr); ch 9, turn. **NEXT ROWS :** Work following diagram; for sm over om, work 2 dc in om and dc in next dc. At end of row 82, fasten off (see black wedge).

COASTER : Ch 10 + 3 to turn (= first dc throughout). **ROW 1 :** Beg with 5th st from hook, work 9 dc; ch 6 (3 ch for base of 1-mesh inc and 3 ch to count as first dc on row 2), turn. **ROW 2 :** Beg with 5th st from hook, work 3 dc, * 1 ch, 1 shell <sh> (= sk 2 sts, dc + 1 ch + dc in next st), rep from * once more, 1 ch, sk 2 sts, dc in next st, 1-sm inc same as for Placemat (that is, work 3 tr as bef); ch 6, turn. **ROW 3 :** Beg same as on row 2, work 3 dc, 1 ch, sk 2 sts, sh in next st, * 1 ch, sh over next sh, rep from * once more, 1 ch, sh in first dc of sm, 1 ch, sk 2 sts, dc in next st, 3 tr; ch 6, turn.

NEXT ROWS : Work following diagram, after row 18, dec at each edge to corresp (= at beg of row, sl st across req number of sts; at end of row, leave req number of sts unworked). At end of row 33, fasten off (see black wedge).

NAPKIN ENVELOPE : Beg at edge of flap, ch 43 + 3 to turn (= first dc throughout). **ROWS 1-56 :** Work following diagram, inc in same way as for Placemat. At end of row 56, fasten off (see black wedge). Fold completed piece along top of row 37 WS tog. Inserting hook thru both thicknesses in corresp sts, work each side closed with sl sts.

GAUGE : 4 ins square =
17 meshes x 22 1/2 rows

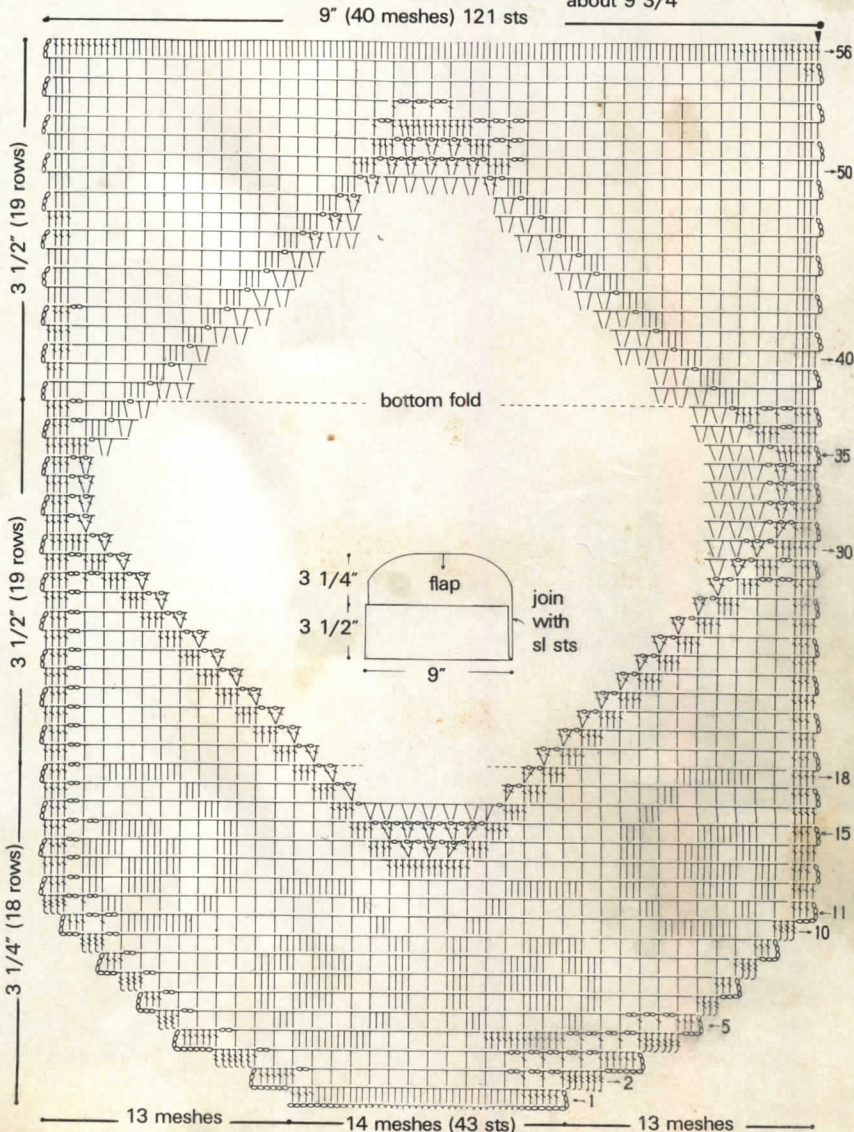
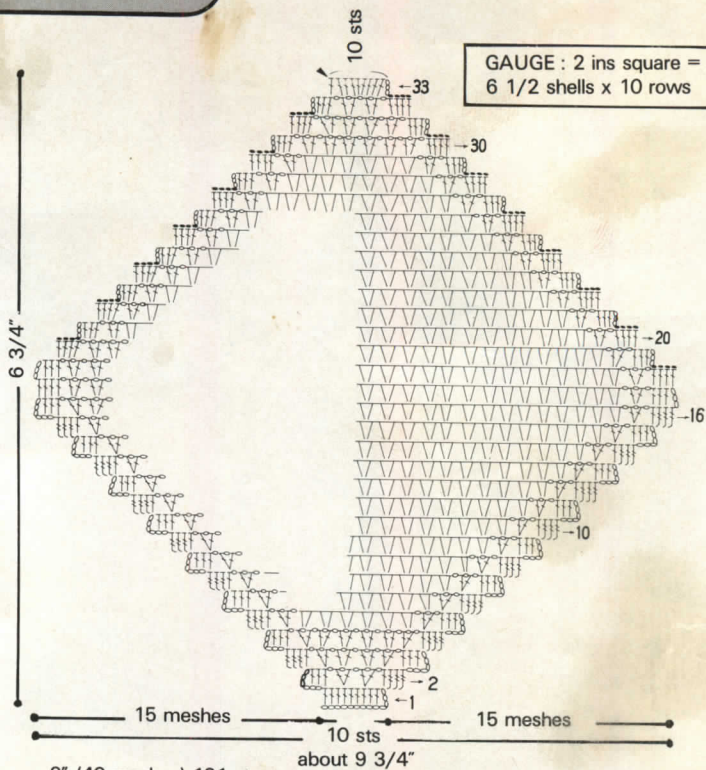

FILET CROCHET

Elegant dining

GAUGE : 4" square =
16 meshes x 20 rows

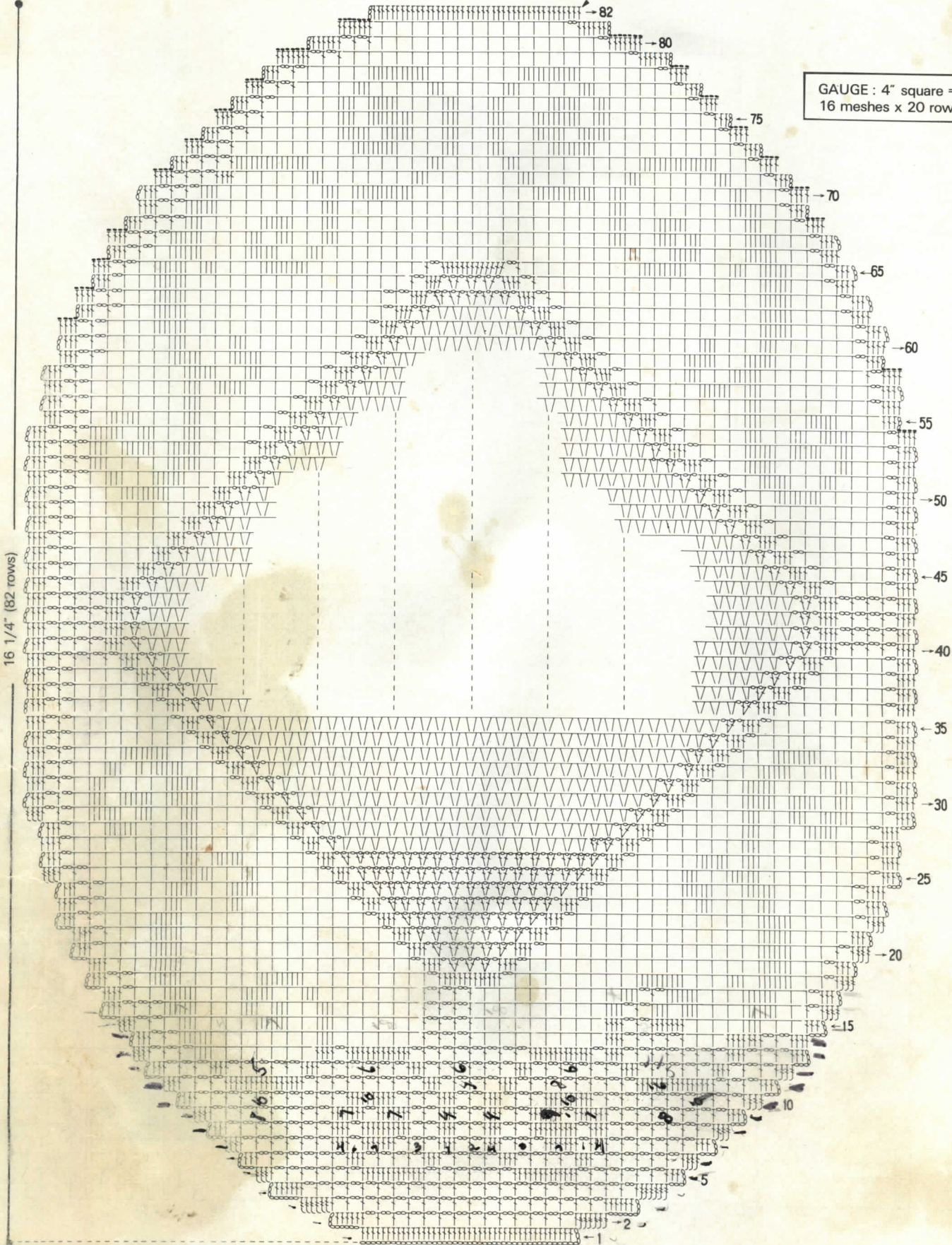

16 1/4" (82 rows)

22 meshes

beg ch : 43 sts (14 meshes)

22 meshes

14 1/4"

27

VINEYARD
MEMENTO

By Elizabeth Hiddleston

SIZE:
17 1/4 by 14 1/4 inches.

MATERIALS:
Crochet cotton no. 10, white,
about 310 yds. Steel crochet
hook US size 7 or SIZE FOR
GAUGE.

GAUGE:
4" square = 15 meshes and 14
rows.

TO MAKE
MAT: Ch 181 + 6 to turn (4 ch
count as first tr and 2 ch form
first open mesh or om). ROW 1:
Tr in 10th st from hook, then

work * 2 ch, sk 2 sts, tr in next
st, rep from * across = 60 om in
all; ch 6, turn each row. ROW
2: Tr in top of next tr, 5 bars (= * 5 ch, sk next tr, tr in next tr,
rep from * 4 more times), 1 om,
2 solid meshes <sm> (= * 2 tr
in ch-2 lp below, tr in next tr, rep
from * once more), 1 om, 3 bars,
18 om, 3 bars, 1 om, 2 sm, 1 om,
5 bars, 1 om. ROWS 3-44:
Work following diagram. For 2
sm over bar, work 6 tr thus: 2 in
ch-5 lp below, 1 in 3rd st of ch-5
lp, 2 in same ch-5 lp and tr in
next tr. At end of row 17, ch 4
to turn. At end of row 44, do
NOT fasten off, ch 4 and turn.
EDGING: Work RND 1 follow-
ing detail diagram, having 4 tr

grps in ch-2 lps; last 3 ch sts =
dc in top of ch-4. On RND 2,
work corner shells in tr and side

shells in dc; close with sl st in
top of ch-4. Fasten off (see black
wedge).

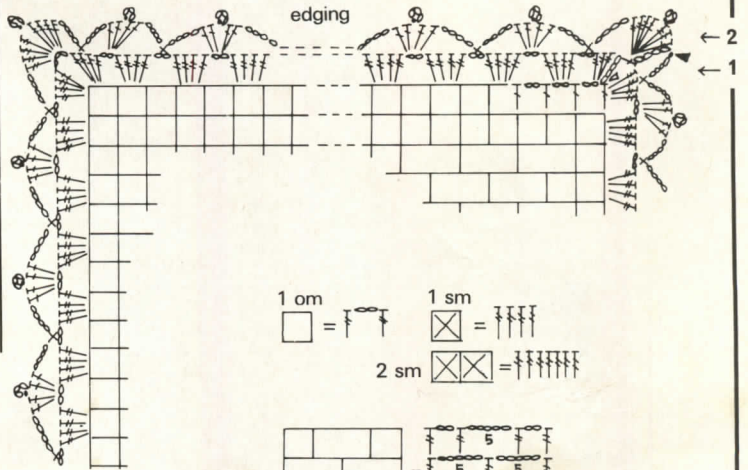

GAUGE: 4" square =
15 meshes x 14 rows

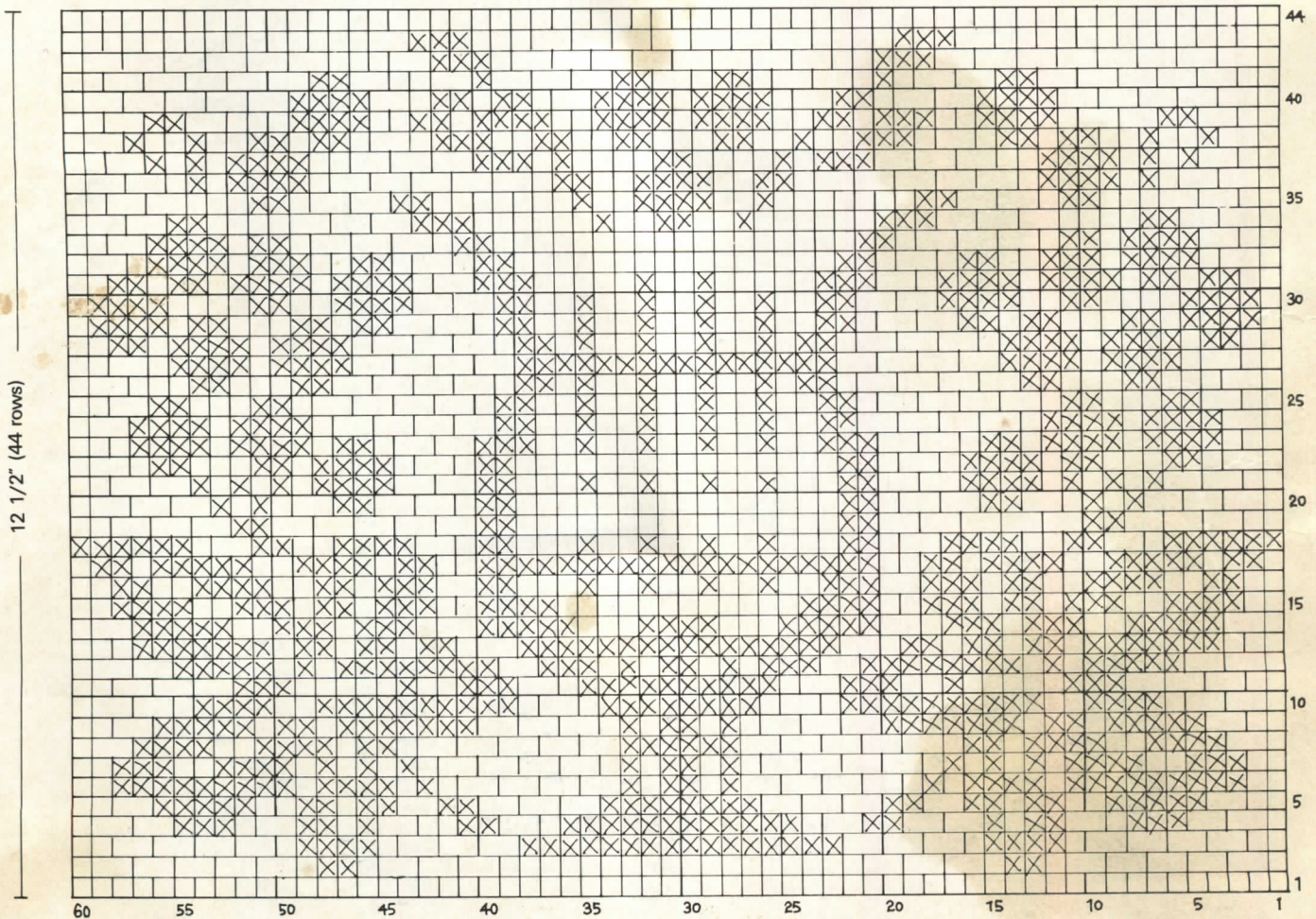

beg ch : 181 sts (60 meshes) 15 3/4"



SWEET SCENTS

By Bernadette Baldelli

SIZE:
White mat, 7 by 7 3/4 inches.
Pink mat measures 8 3/4" in diameter.

MATERIALS:
For white mat, crochet cotton no. 20, about 90 yds, and steel crochet hook US size 13. For rose mat, shiny crochet cotton (or fil d'Ecosse) no. 20, pale pink, about 170 yds, and steel crochet hook US size 11.

TO MAKE WHITE MAT
FIRST HALF (A): Beg at center of piece, ch 91 + 3 to turn (= first dc throughout). **ROW 1:** Beg with 5th st from hook work 5 dc, 11 ch, sk 11 sts, dc in each of next 4 sts, * 2 ch, sk 2 sts, dc in next st, rep from * once more, dc in each of next 6 sts, 5 ch, sk 5 sts, dc in each of next 13 sts, 5 ch, sk 5 sts, dc in each of next 7 sts, ** 2 ch, sk 2 sts, dc in next st, rep from ** once more, dc in each of next 3 sts, 11 ch, sk 11 sts, 7 dc; ch 9 (= 6 for base of 2-sm inc and 3 to count as first dc on row 2), turn. **ROWS 2-20:**

GAUGE: 4" square = 21 meshes x 23 rows

Work following diagram. For sm incs: at end of even rows, work tr as per how-to; at end of odd rows, work extra ch sts as shown. As of row 14, dec at each edge thus: at beg of row, sl st across req number of sts; at end of row, leave req number of sts unworked. Complete each scallop separately (for 2nd scallop, attach thread with sl st WS facing, as per white wedge). Fasten off (see black wedges).

SECOND HALF (B): RS facing, attach thread with sl st in beg ch (see white wedge) and work to correspond to First Half.

TO MAKE ROSE MAT
FIRST HALF (A): Beg at center, ch 139 + 3 to turn (= first dc throughout). **ROW 1:** Beg in 5th st from hook, work 6 dc, 11 open meshes (<om> (= * 2 ch, sk 2 sts, dc in next st, rep from * 10 more times), 2 solid meshes <sm> (= dc in each of next 6 sts), 1 om, 4 sm (= dc in each of next 12 sts), 1 om, 3 sm (= dc in each of next 9 sts), 2 om, 1 sm (= dc in each of next 3 sts), 5 om, 2 sm, 2 om, * 1 sm, 2 om, rep from * once more, 1 sm, 1 om, 2 sm; ch 3, turn each row. **ROWS 2-23:** Work following pat diagram, alternate om and sm as shown. As of row 8, dec at each edge to corresp thus: at beg of row, sl st across req number of sts to start new row in corresp dc; at end of row, leave req number of sts unworked. At end of row 23, fasten off.

SECOND HALF (B): RS facing, attach thread with sl st in beg ch and work following pat diagram (see tiny arrow for direction of work). At end of row 23, fasten off.

SM INCS USING TR

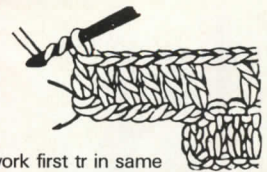

work first tr in same st as last dc, each following tr in first cross strand of prev tr; work 2 tr in this way for each new sm

GAUGE: 4" square = 21 meshes x 21 rows

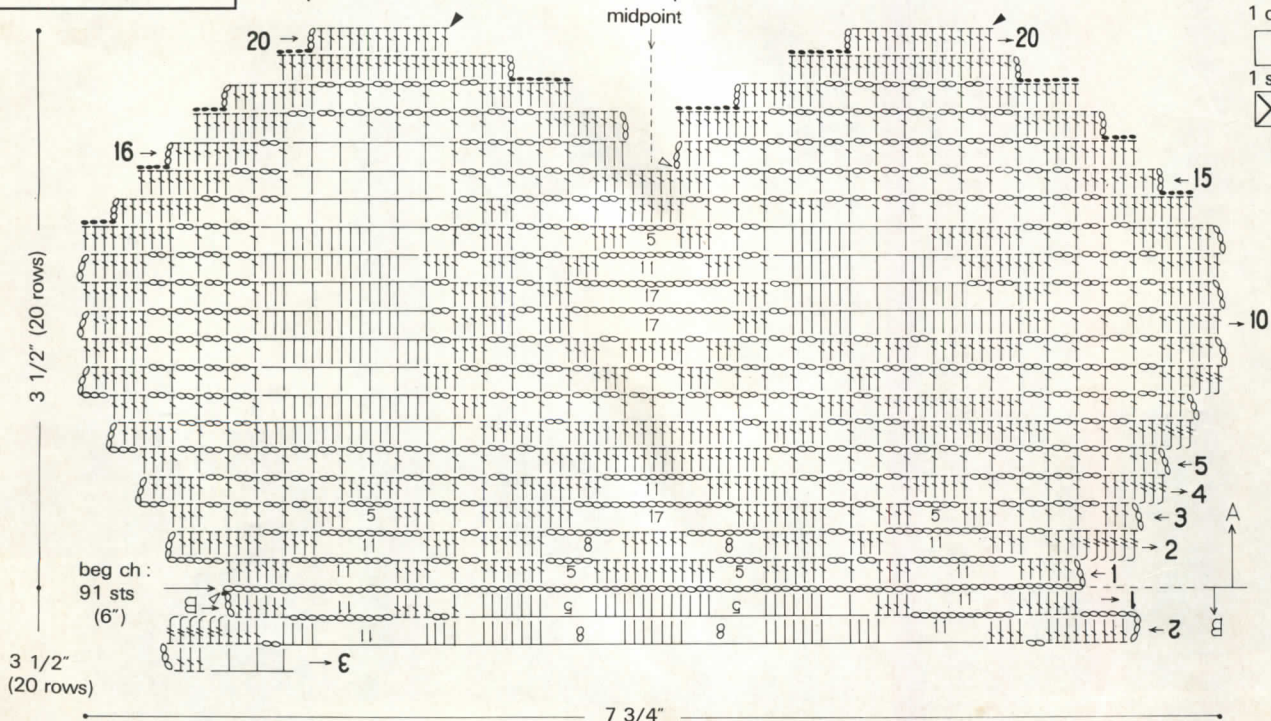
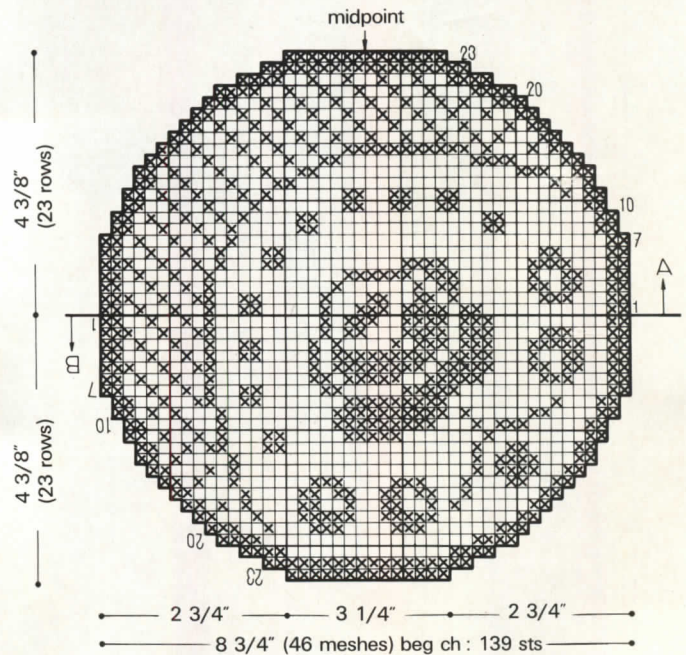



29

GOOD READ

By Chantal Chevallier

SIZE:
Book Mark, 2 1/4" wide, 7 3/4" long. For Book Cover, see diagram.

MATERIALS:
Crochet cotton no. 10, white, about 500 yds. Steel crochet hook US size 9 or **SIZE FOR GAUGE.**

GAUGE:
4" square = 15 1/2 meshes and 20 1/2 rows. **TO SAVE TIME, TAKE TIME TO CHECK GAUGE.**

TO MAKE BOOK COVER: Ch 187 + 3 to turn (= first dc throughout). **ROW 1:** Dc in 5th st from hook and in each st across; ch 3, turn each row. **ROW 2:** ** 2 solid meshes <sm> (= dc in each of next 6 sts), 2 open meshes <om> (= * 2 ch, sk 2 sts, dc in next st, rep from * once more), rep from ** once more, 21 sm (= dc in each of next 63 sts), 4 om, 21 sm, *** 2 om, 2 sm, rep from *** once more. **ROWS 3-39:** Work following diagram. For sm over om, work 2 dc in ch-2 lp below, dc in next dc. At end of row 39, fasten off.

FINISHING: Fold flaps to inside (baste in place) and work 1 row crab stitch (= sc worked from left to right instead of from right to left) across top and bottom edges. Across flaps, insert hook thru both thicknesses.

BOOK MARK: Ch 28 + 3 to turn (= first dc throughout). **ROW 1:** Dc in 5th st from hook and in each st across; ch 3, turn. **ROWS 2-43:** Work following pat diagram, alternate om and sm as shown; ch 3 (or 5 for om), turn each row. On rows 40-43, dec 1 om at each edge to corresp (= at beg of row, sl st across 4 sts; at end of row, leave last 3 sts unworked). Fasten off.

GAUGE: 4 inches square = 15 1/2 meshes x 20 1/2 rows

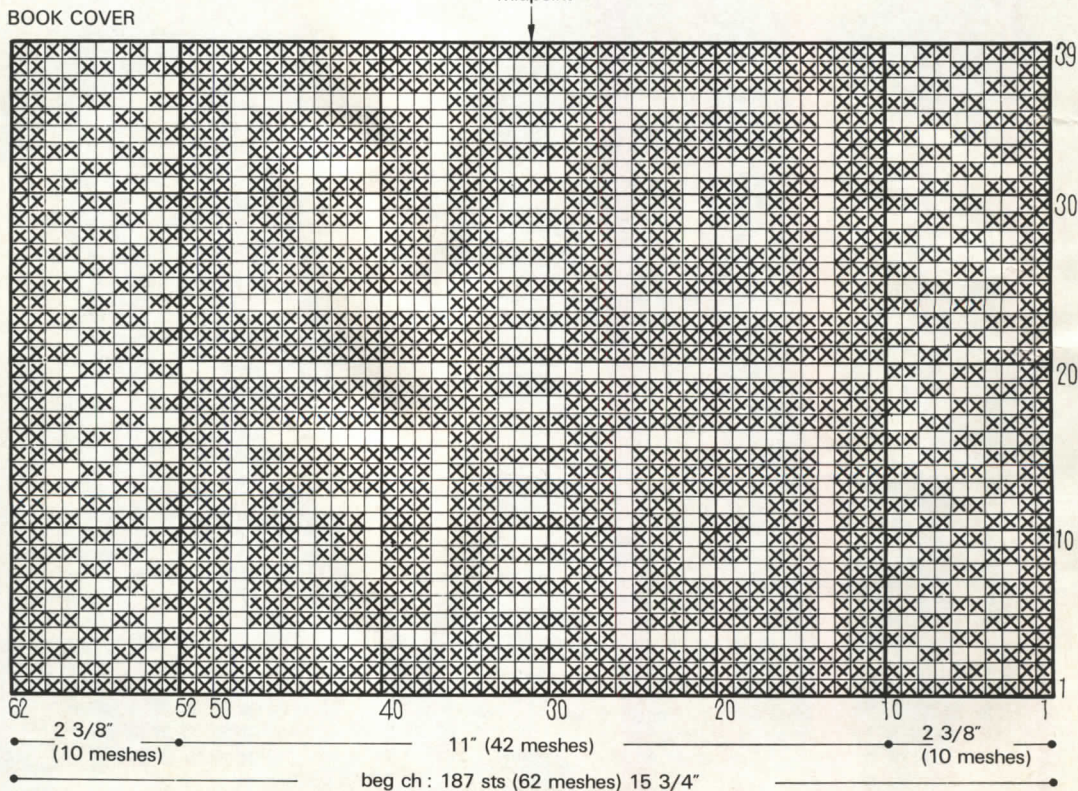
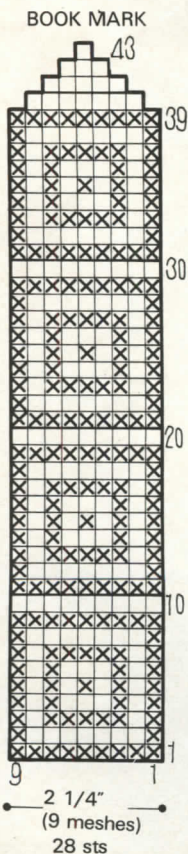
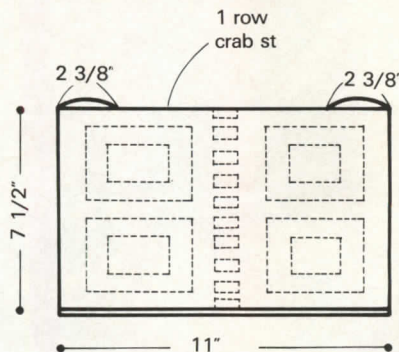
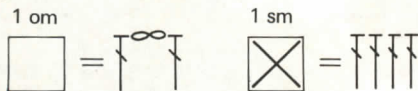
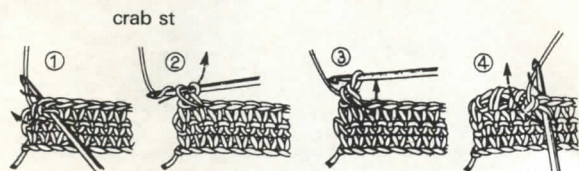

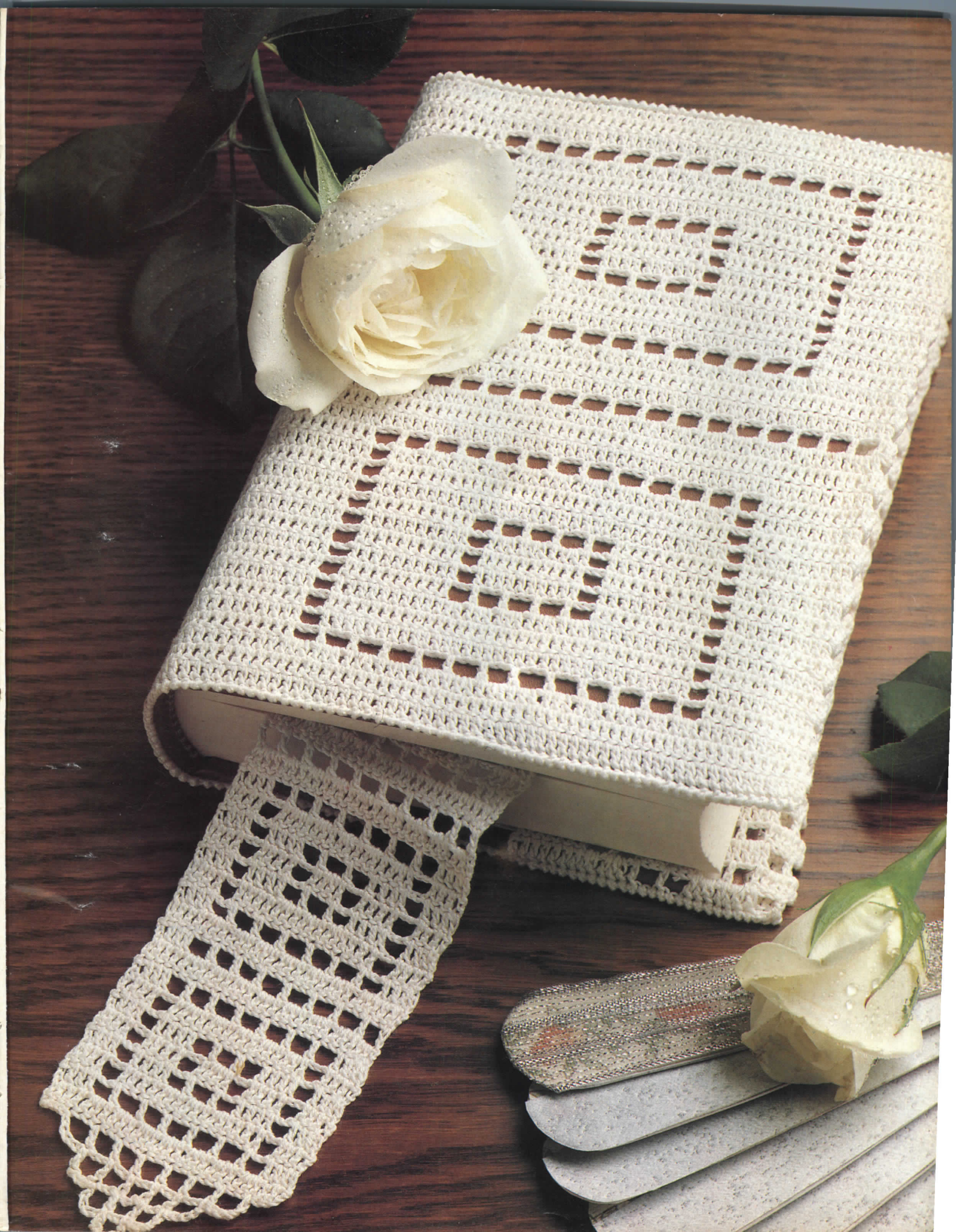

30

GRAPE FESTIVAL

Elizabeth Hiddleston

SIZE:
11 3/4" by 18 1/4", including edging 5/8" deep.

MATERIALS:
Crochet cotton no. 20, ecru, about 350 yds. Steel crochet hook US size 11 (size 9 if you tend to work very tightly) or **SIZE FOR GAUGE.**

GAUGE:
4 inches square = 14 meshes and 14 1/2 rows. If you use crochet cotton no. 5 and steel crochet US size 2, mat will measure about 27 1/2 by 18 1/2 inches.

TO MAKE:
Ch 181 + 5 to turn (3 ch count as first dc and 2 ch form first open mesh or om). **ROW 1:** Dc in 9th st from hook, then work * 2 ch, sk 2 sts, dc in next st, rep from * across = 60 om in all; ch 5, turn each row. **ROW 2:** 12 om, 1 sm (= 2 dc in ch-2 lp below, dc in next dc), 6 om, 1 sm, 20 om, 1 sm, 6 om, 1 sm, 12

om. **ROWS 3-39:** Work following pat diagram, alternate om and sm as shown. At end of row 39 do NOT fasten off, ch 1, and, beg at left-hand edge, cont with 1 rnd **EDGING:** insert hook in corresp om (see detail diagram) and distribute shells <sh> as per pat diagram (= 10 across height and 15 across width). After completing 3rd tr of each sh work thus: 5 ch, yo, pull up lp in last tr, yo and draw thru 2 lps on hook, yo twice, pull up lp in same om as last 3 tr, * yo and draw thru 2 lps on hook, rep

from * once more, yo and draw thru all 3 lps on hook (= 2-st cluster made), then complete sh with 2 more tr in same om; close with sl st in first sc. Fasten off (see black wedge).

GAUGE: 4 ins square = 14 meshes x 14 1/2 rows

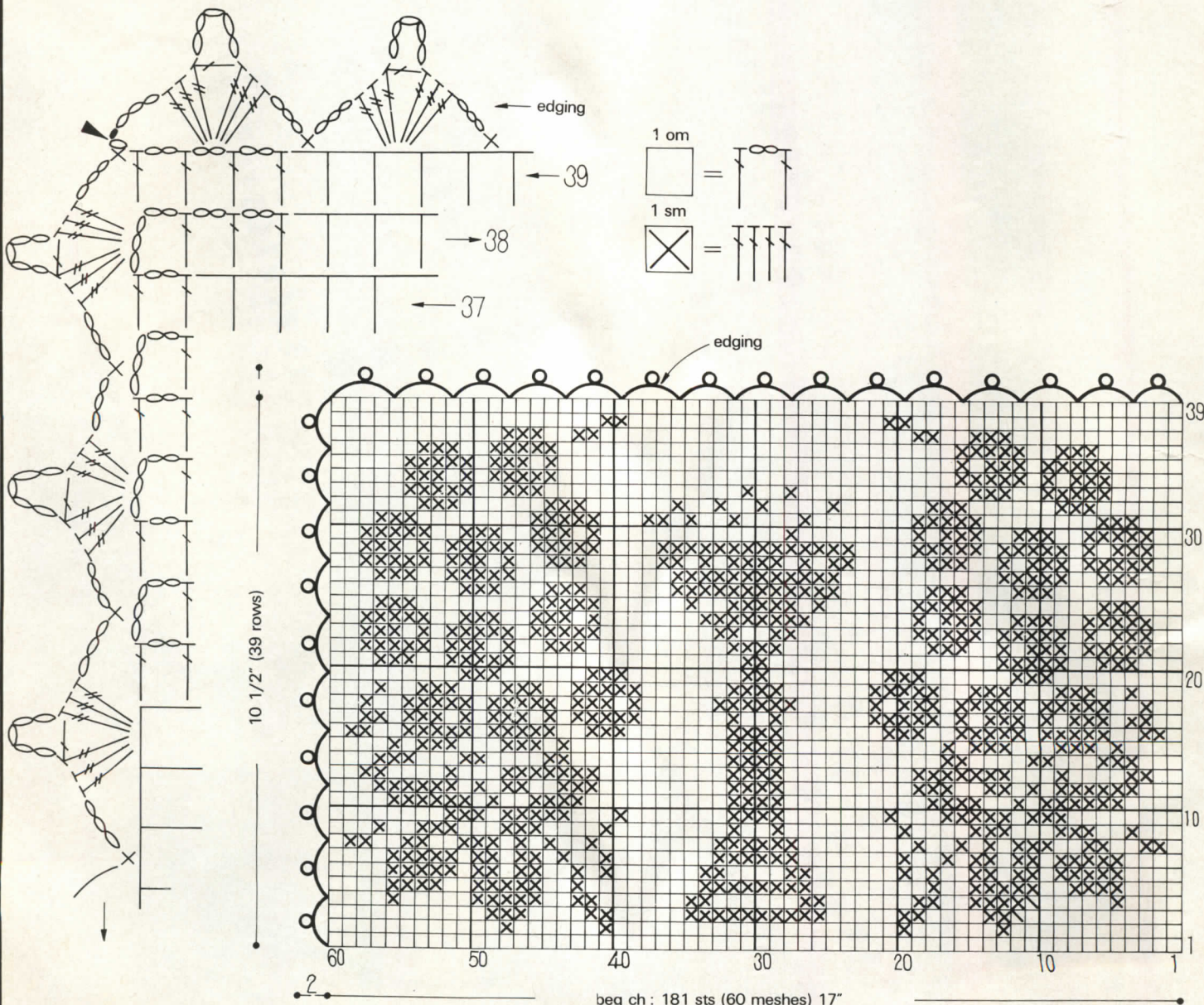



31

WILD GOOSE

By Glendola Hodges

SIZE:
20 inches on each side.

MATERIALS:
Shiny quality crochet cotton (or fil d'Ecosse) no. 10, white, about 310 yds. Steel crochet hook US size 4 or **SIZE FOR GAUGE.**

GAUGE:
4" square = 13 meshes and 15 rows (stretch swatch before measuring). If you use crochet (tatting) cotton no. 50 and steel crochet hook US size 15, mat will measure about 10 1/2" on each side.

TO MAKE
MAT and EDGING: Ch 196 + 5 to turn (3 ch count as first dc and 2 ch form first open mesh or om). **ROW 1:** Dc in 9th st from hook, then work * 2 ch, sk 2 sts, dc in next st, rep from * across = 65 om in all; ch 5, turn each row. **ROW 2:** 52 om, 1 solid mesh <sm> (= 2 dc in ch-2 lp below, dc in next dc), 12 om. **ROWS 3-75:** Work following pat diagram, alternate om and sm as shown. At end of row 75, fasten off. **WS facing,** attach thread with sl st in beg ch and work 1 row om, inserting hook in same ch sts as for first row of mat; at end of row ch 1, turn and work 1 rnd sc all around mat (see detail); close with sl st in first sc. Fasten off (see black wedge).

FINISHING: Place completed mat, WS facing, on flat surface covered with clean white fabric. Spray-starch mat, stretch carefully to size and fix in place with never-rust dressmaker's pins. Allow to dry.

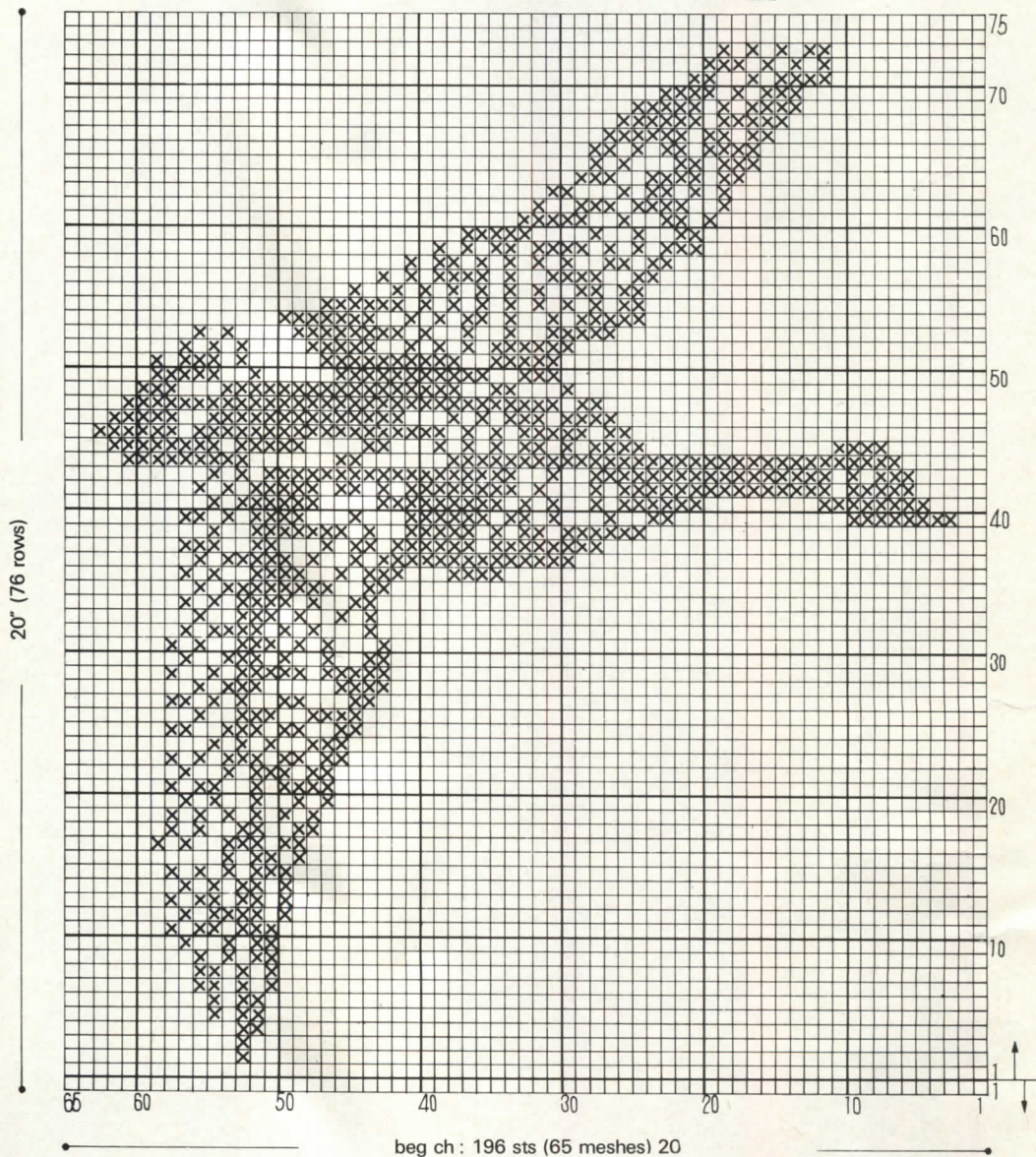
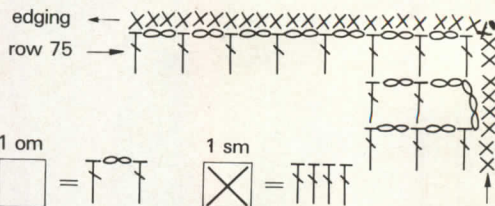

GAUGE: 4" square = 13 meshes x 15 rows



MEDALLION

SIZE:
About 39 1/2" on each side.

MATERIALS:
DMC Cebelia (Art. 167) crochet cotton no. 20, white, 2,875 yds.
Steel crochet hook US size 11 or
SIZE FOR GAUGE.

GAUGE:
4 inches square = 20 meshes and
20 rows. One motif measures
16 1/4" on each side.

TO MAKE
MOTIFS A, B, C and D: For
each motif, ch 88 + 5 to turn (3
ch count as first dc and 2 ch
form first open mesh or om).
ROW 1: Dc in 9th st from hook,
then work * 2 ch, sk 2 sts, dc in
next st, rep from * 4 more times
(= 6 om in all), dc in each of
next 51 sts, 6 om; ch 14 (9 ch
form base for 3-om inc, 5 ch are

Tch for row 2), turn. ROW 2:
Dc in 9th st from hook, 3 om, 6
solid meshes <sm> (= dc in
each of next 18 sts), * 1 picot
lacet (= 3 ch, sk 2 sts, sc in next
st, 3 ch, sl st in top of sc = picot
made), 3 ch, sk 2 sts, dc in next
st, 1 bar (= 5 ch, sk 5 sts, dc in
next st), rep from * twice more,
1 lacet, 1 om, 6 sm, 1 om, 3-om
inc thus: 2 ch, 1 triple triple
crochet <trtr> (= yo 4 times,
pull up lp in same st as last dc,
yo and draw thru 2 lps on hook
5 times in all), then work (2 ch,
trtr bet 3rd and 4th cross strand
of last trtr) twice; ch 11 (6 ch
form 2-om inc, 5 ch are Tch for
row 3), turn. ROWS 3-81: Work
following Motif A and respective
pat diagram. As of row 56, dc
thus: at beg of row, work req
number of sl sts; at end of row,
leave req number of sl sts un-
worked. At end of row 81, fasten
off. Now, RS facing, attach
thread with sl st in 3rd st to the

left of first dc of row 1 (see white
wedge) and work 1 rnd edging

all around motif thus: 9 ch (3 ch
count as first dc and 6 ch form

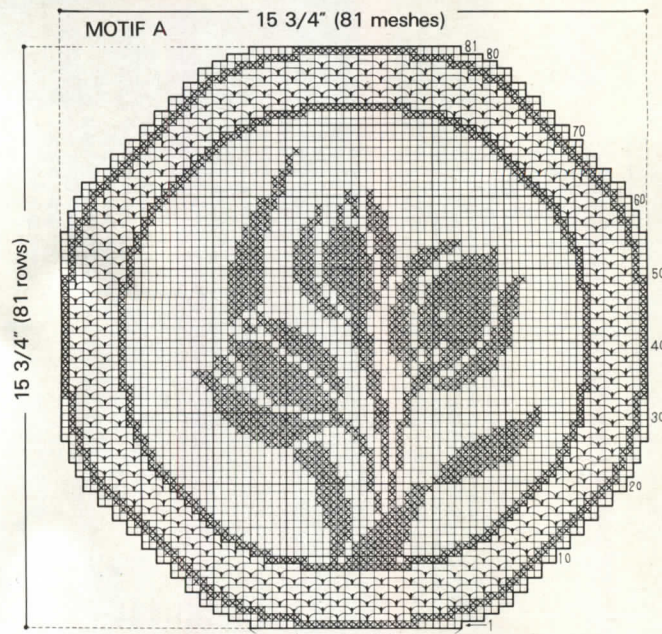

beg ch : 88 sts
(29 meshes)

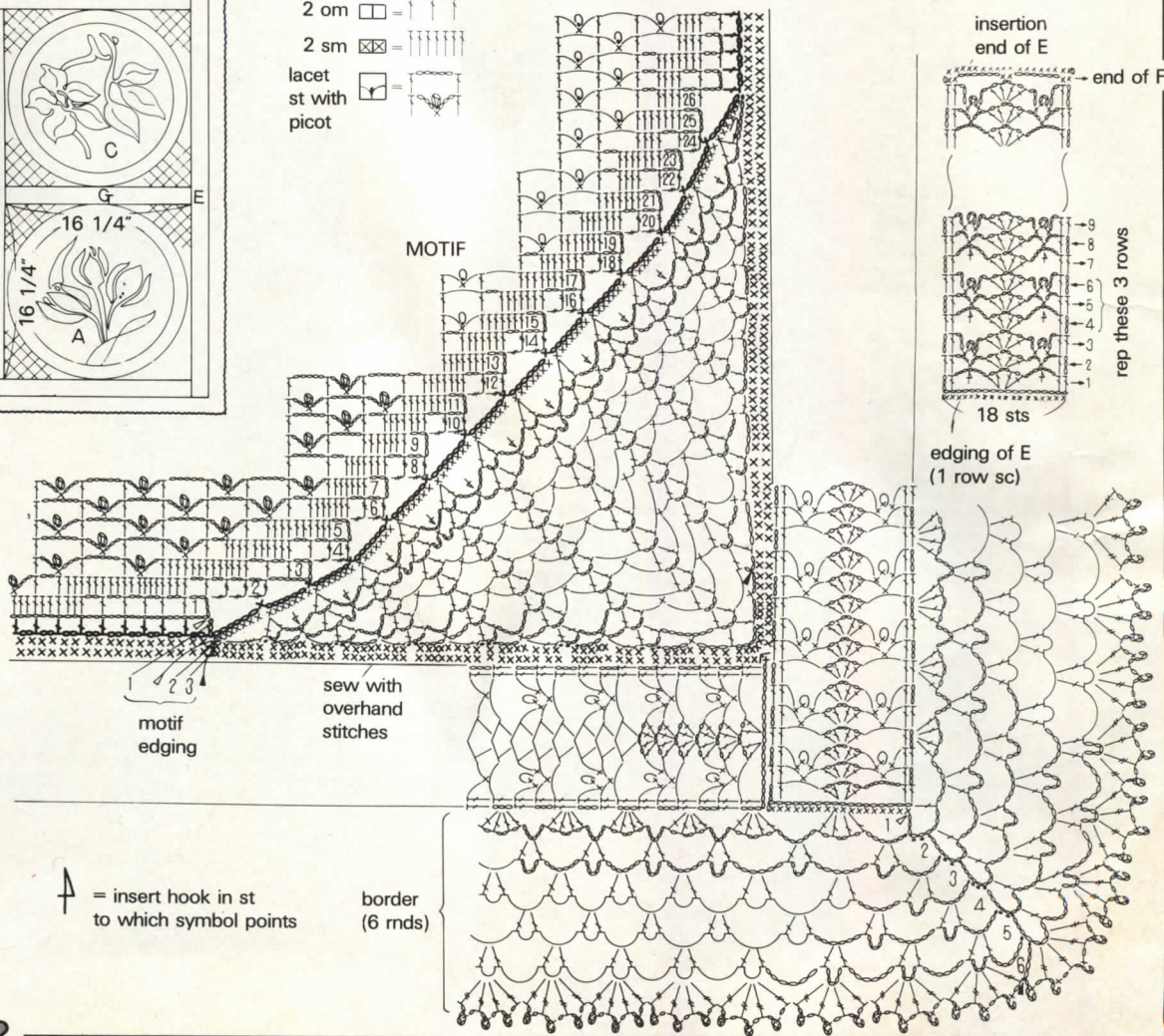
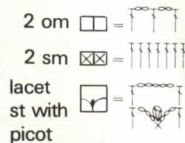
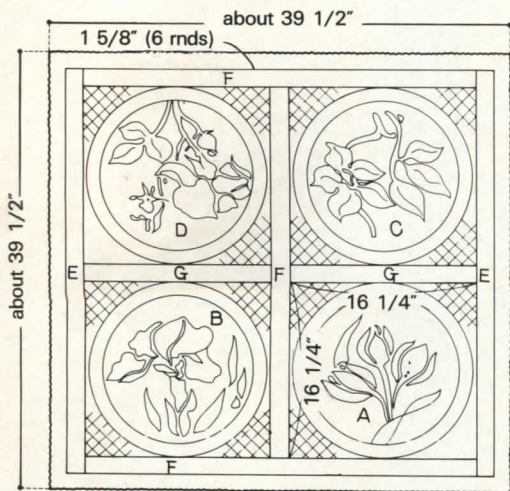

FILET CROCHET

first ch lp), then work ch lps across rounded edges and om across straight edges as shown in bold type; close with sl st in 3rd

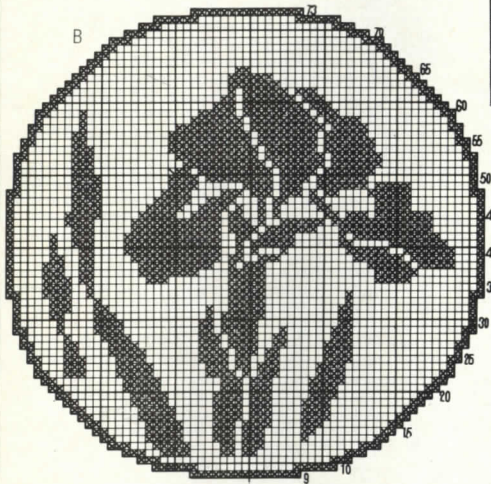

midpoint

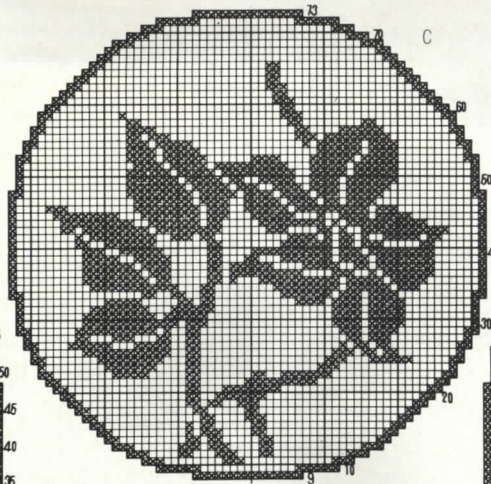

midpoint

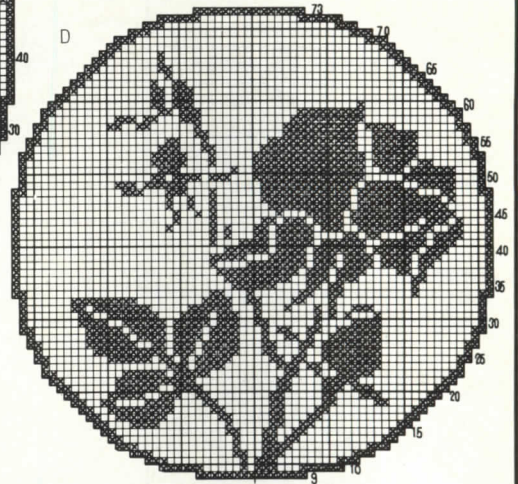

midpoint

st of ch-9, then complete each corner separately, working back and forth in rows. At end of row 1, join last (7th) sc to first dc of straight edge with sl st; ch 5, turn (see tiny arrow). On row 2, end with double triple crochet <trtr> (= yo 3 times, pull up lp in last sc, complete same as trtr); turn and cont with 2 sl sts to beg new row in center st of ch-3 lp of first shell <sh>. Up to row 11, end all odd rows with sc in 4th st of ch-7 lp of last ch lp, dc in 2nd ch st of sh, ch 4, turn; end all even rows with sh in 2nd ch st of last sh, dc in last sc, turn, work 3 sl sts to beg new row in center of first sh. On row 13, end with sl st in center of last sh and fasten off. Complete rem 3 corners in same way, then work 2 rnds sc all around square as shown. Fasten off (see black wedge).

INSERTIONS: Complete 2 Bands E with 56 motifs each; 3 Bands F with 52 motifs each; and 2 Bands G with 27 motifs each (do not work sc row at end of bands F and G). Sew-join bands with overhand stitches, arranging motifs as shown.

BORDER: RS facing, attach thread with sl st in sc at corner (see white wedge). **RNDS 1-6:** Work following diagram. Up to rnd 5, close each rnd with sl st in top of ch-3 (= first dc through-out) and cont with sl st in each of next 3 sts to beg new rnd in 3rd st of ch-6 lp at corner; at end of rnd 5, cont with 1 sl st in first ch lp. Work dc on rnds 2-5 in 3rd and 4th st of each ch-6 lp. On rnd 6, picots = 4 ch, sc in 2nd st of ch-4 just made, 1 ch; close with sl st in top of ch-4 (= first tr). Fasten off.



33

SAY IT WITH ROSES

SIZE:
Approximately 35 1/2" square.

MATERIALS:
DMC Cebelia (Art. 167) crochet cotton no. 20, white, 2,025 yds (that is, 5 balls). Steel crochet hook US size 9 or **SIZE FOR GAUGE.**

GAUGE:
First 4 rounds (that is, 9 meshes) measure 2 inches on each side.

TO MAKE
TABLE TOPPER: Beg at center, ch 12 and close with sl st to form ring. **RND 1:** 8 ch (3 ch count as first dc throughout, 5 ch form corner ch lp), dc in same st as sl st, then work (2 ch, sk 2 sts, dc + 5 ch + dc in next st), end with 2 ch; close each rnd with sl st in top of ch-3 and cont with 3 sl sts to beg new rnd in center ch st at corner. **RND 2:** ** dc + 5

2 ch, sk 2 sts, dc in next st), 3 sm (= dc in each of next 9 sts), 13 om, 3 sm, 2 bars, 1 om, 4 sm, 4 om, 2 ch, rep from ** around. **RNDS 25-59:** Work following diagram, rep same pat bet each corner. At end of rnd 59, fasten off. **ROWS 60-76:** RS facing,

start
here
(center)

ch + dc in 3rd st of ch-5 lp, work (2 ch, dc in next dc) twice, 2 ch, rep from ** around. **RNDS 3-22:** Cont in same way as on rnd 2, work 2 extra meshes on each side and on each rnd. Thus, on rnd 22, you should have 1 ch-5 lp at each corner and 43 open meshes <om> on each side. **RND 23:** ** dc + 5 ch + dc in 3rd st of ch-5 lp at corner, 8 om (= * 2 ch, dc in next dc, rep from * 7 times more), 5 solid meshes <sm> (= dc in each of next 15 sts), 19 om, 5 sm, 7 om, 2 ch, rep from ** around. **RND 24:** ** dc + 5 ch + dc in 3rd st of ch-5 lp at corner, 5 om, 4 sm (= dc in each of next 12 sts), 2 bars (= * 5 ch, sk 5 sts, dc in next st, rep from * once more), 1 om (=

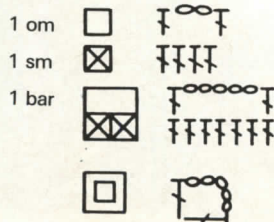

GAUGE: rnds 1-4 =
2 ins on each side

FILET CROCHET

attach thread with sl st in 10th of 10 dc located in center on any side. Refer to diagram and work until you reach first dc of 10-dc grp on next side, turn, sl st

across last 10 dc (dec made), 3 meshes, 3 ch (= first dc on row 61), then cont to work section back and forth in rows, dec at each edge to corresp. Complete

each section separately in this way.

EDGING : RS facing, attach thread with sl st, ch 1 and work all around Table Topper thus : *

3 sc, 1 picot (= 3 ch, sl st in top of last sc), rep from * around (do not work picots in indented corners); close with sl st in first sc. Fasten off.



A MAGIC SELECTION ROW BY ROW

AN ORIGINAL SHELL PATTERN

Tiny shells are the eye-catching feature here. The pattern consists of two rows, repeated over and over again to form a trellis with contrasting raised and flat openwork areas. A pretty-to-look-at design, easy to work up and perfect for a shawl. Use cotton thread to emphasize the relief or soft wool if you go for warmth and comfort. Depending on the yarn chosen, your shawl can be an elegant summertime accessory or a cuddly wrap to put around your shoulders when watching TV on a winter evening.

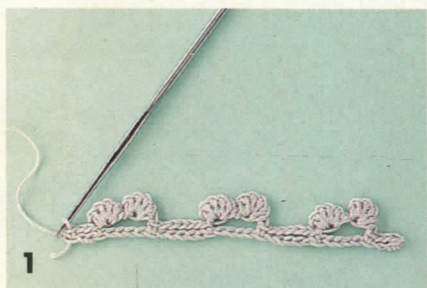
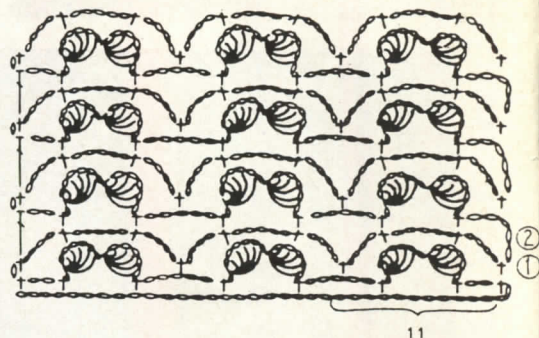

1- Foundation chain and row 1: To obtain 3 complete motifs, ch 33 (that is, 11 ch for each motif) plus 1 ch to turn. First row is RS of work.

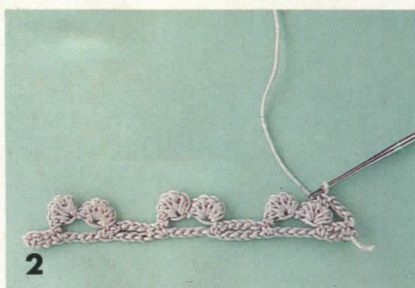

2- Beginning of row 2: After working 1 ch to turn, work sc in sc, 4 ch and sc under remaining strand of 3rd of 5 sts on base of first shell.

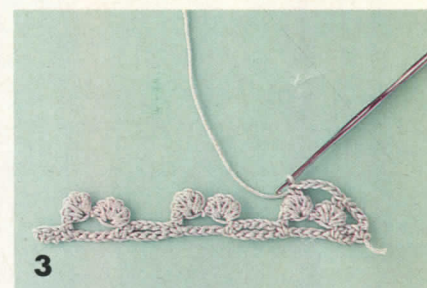

3- Chain loop over shells: Ch 5, work sc in same way as last sc was worked but in next shell.

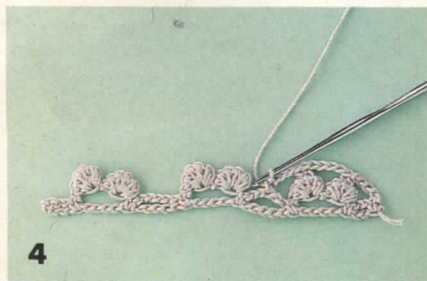

4- Chain loop between motifs: Work 4 ch, sc in 3rd st of ch-5 lp on row 1, cont with 4 ch.

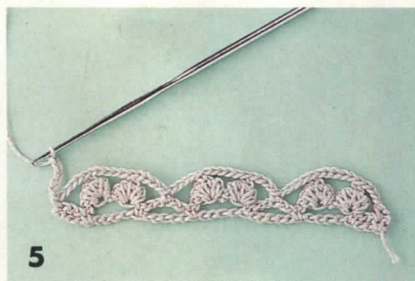

5- End of row 2: Work in same way over each of 3 motifs, end with 4 ch, sc in last sc; ch 5, turn.



6- Beg of row 3: Here you see sc worked in next sc, 2 shells, 1 ch, sc in next sc, 5 ch, sc in sc of next motif and you have just worked 5 ch for base of new shell.



7- Shell: Beginning with 5th st of ch-5 just made, work partial hdc (that is: yo, pull up lp in st) in each of 5 ch sts = you should have 11 lps on hook.



8- Complete shell thus: yo and draw thru all 11 lps on hook.



9- Second shell: Work 6 ch sts, that is, 1 to separate the 2 shells and 5 for base of 2nd shell.



10

10- Beginning with 6th st of ch-6 just made, work 5 partial hdc in same way as for preceding shell.



11

11- The next stage is yo and draw thru all 11 lps on hook, work 1 ch and sc in next sc. Here you see 5 ch worked for next ch lp.



12

12- Join to next motif with sc in top of next sc. Here you see 5 ch worked for base of first shell of next 2-shell motif. Work in this way for each motif.



13

13- Row 4 : In same way as on row 2, work sc, 5 ch and sc over shells, 4 ch, sc in 3rd st of ch-5 lp on row below, and 4 ch between 2-shell grps.



14

14- Completed swatch consisting of 16 rows in all (8 rows of shells).

A GREAT CLASSIC IN SHELL STITCH

A very feminine present for any festive occasion.

We used a shell stitch for this lovely Victorian purse (called reticule in those far-off days) and worked back and forth in rows (but you may also work in the round).

You can make this accessory without much trouble in the shell stitch shown on the companion diagram or in any other stitch we have provided in this issue. If you choose a very lacy stitch, you will have to line the crochet piece before sewing it to the closure frame (available in stores selling arts and crafts supplies). Complete a swatch, then work a foundation chain with number of stitches equal to twice the total length of the frame to which you will sew the crochet piece, that is : length of B + 2 times length of A and then multiply the result by 2. Work in the round until you obtain a piece in good proportion to the frame. When the crochet piece is finished,

WS facing sew bottom edges closed. To obtain purse width desired, fold each end in to form a triangle and sew to bottom. Sew top of crochet piece neatly to closure frame.

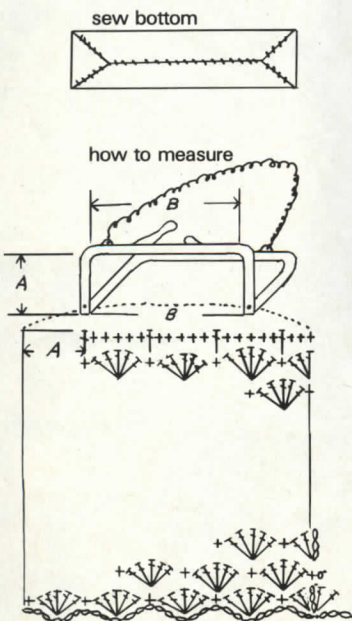

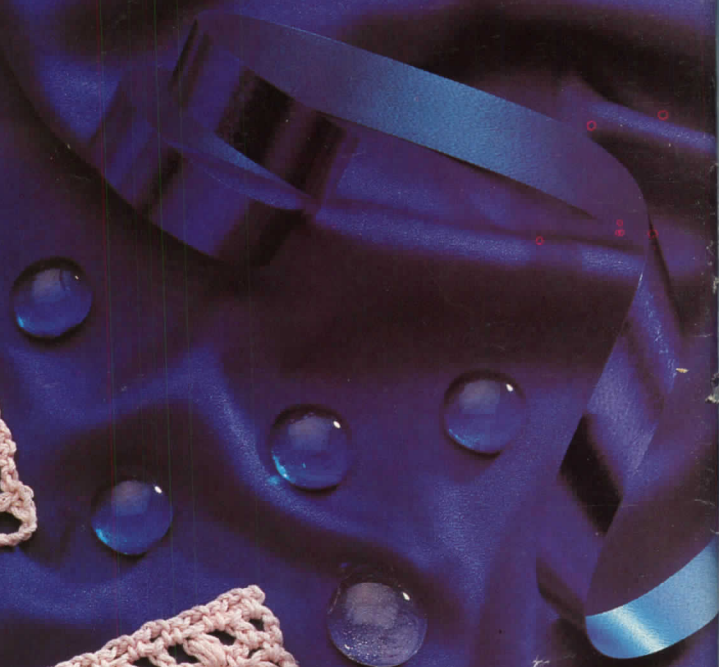
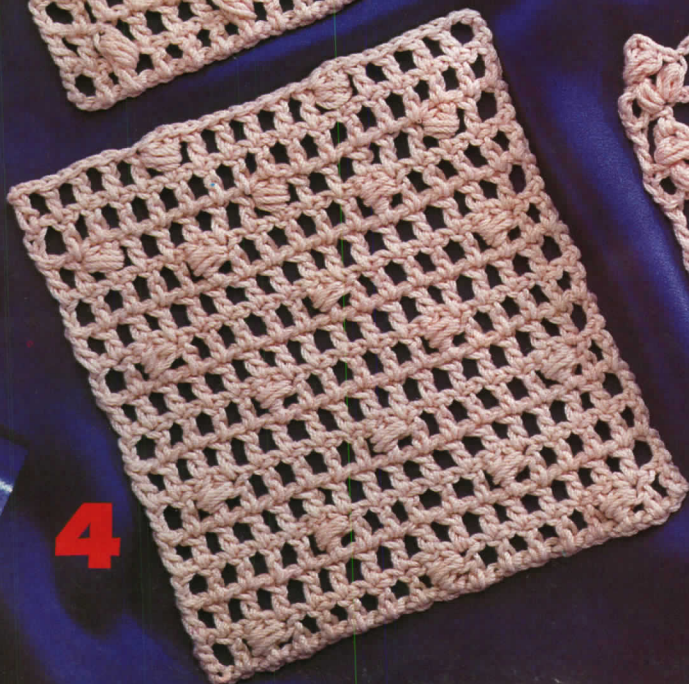
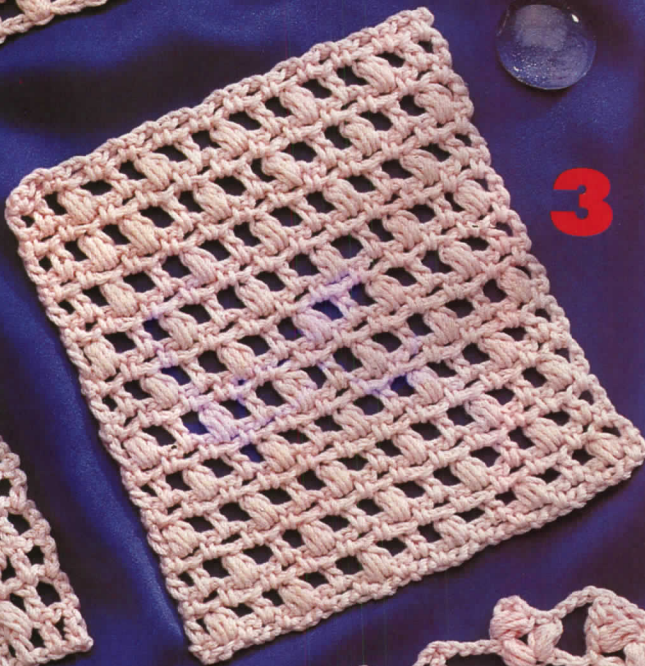
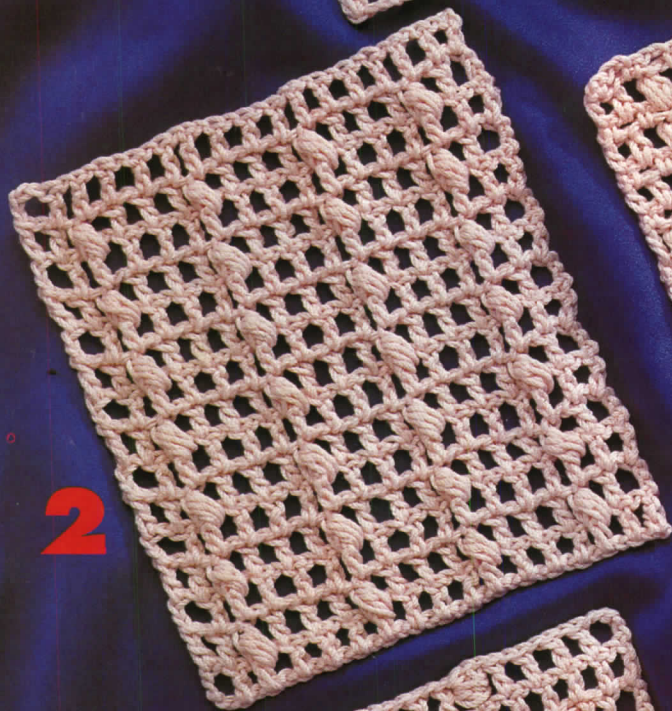
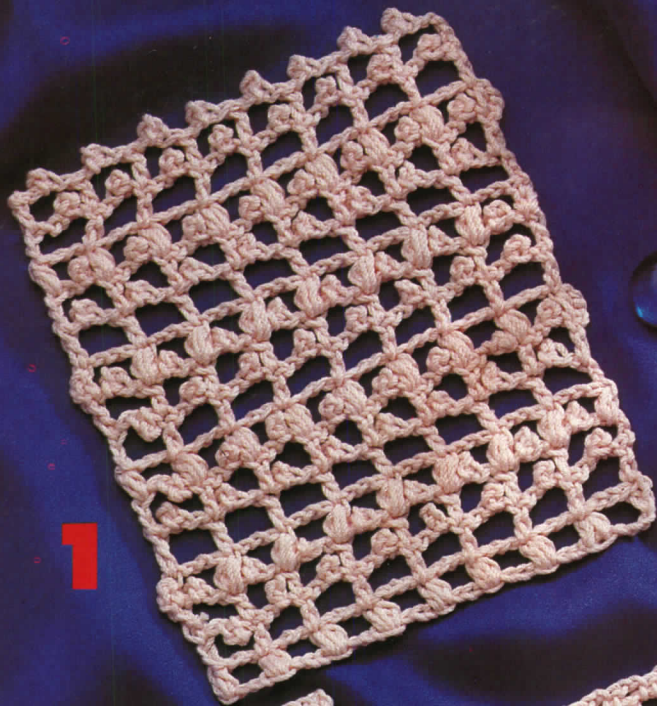

MAGIC SELECTION

PUFF STITCHES

To work the puff (or bobble) stitch, pull up loops for several stitches in (or over) the same stitch on the row below, then yarn over and draw through all loops on hook. You can obtain different-size puffs by choosing

hdc or dc stitches and by working three, four or five such stitches per puff. Here are five patterns, all part of theme and variations on the puff.

Pick one of these to create a lacy top, an edging, a curtain, or any other masterpiece you may have in mind.

After all, the final performance lies in your hands!

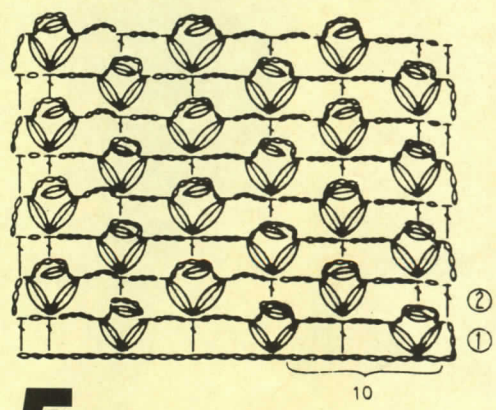
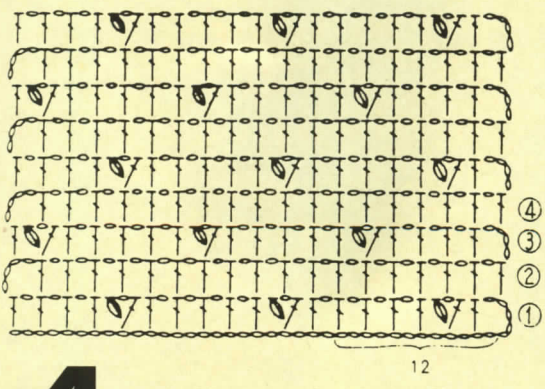
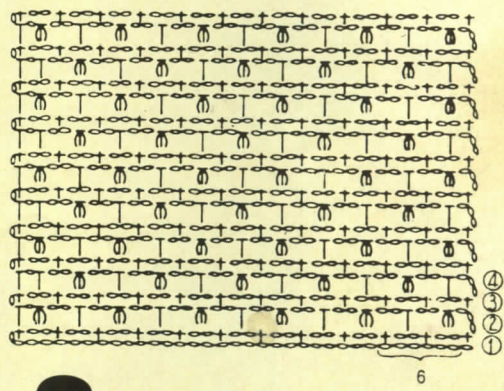
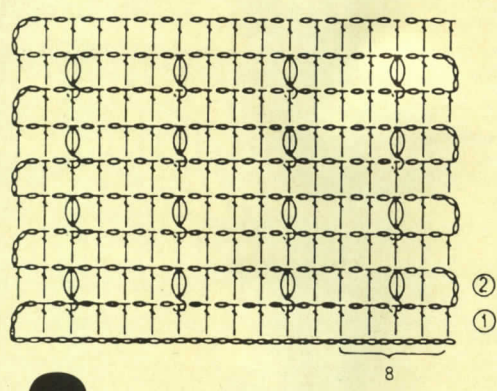
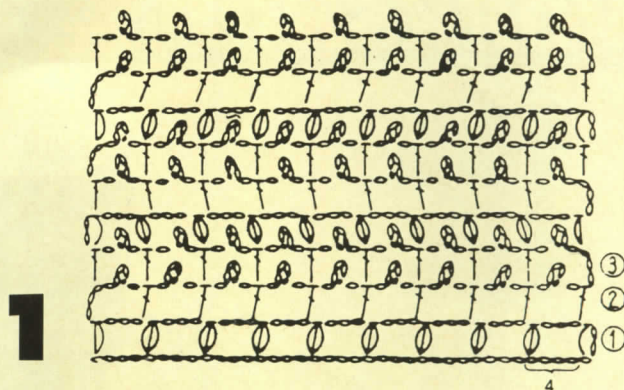

34

YOUR CROCHET

WORKSHOP



POPCORN PULLOVER

This is an exciting colorwork project. You will be working with three colors, guided by our how-to photos every step of the way. Alternating stripes is all there is to the pattern stitch, but the total effect is tasteful and fresh. Take care to feed the thread evenly and your pullover will move fast. For a neat and supple finish, we recommend k1/p1 ribbing, but be sure to pick up the stitches exactly as shown.

SIZE : Bust, 40"-42": Shoulder width, 15 3/4". Sleeve length, 9 3/4". Pullover length, ca. 22".
MATERIALS : 70% cotton, 30% polyester yarn, 50 g or 1 3/4 oz balls (approx. 207 m or 230 yds): 4 balls deep blue, 3 balls each bluish gray and ecru. Steel crochet hook US size 2 (1 if you tend to work tightly) or **SIZE FOR GAUGE.** Set of 4 double-point knitting needles US size 5. Large-eared sewing needle.

GAUGE : 4" square = 12 motifs and 13 rows. **TO SAVE TIME, TAKE TIME TO CHECK GAUGE.**

TO MAKE : Complete front, back and sleeves following respective diagrams. Knit front, back and sleeve ribbings. Sew shoulder seams with over-and-over sts, then knit neckband in the round. To join side and sleeve seams, place pieces RS tog and work sc + ch-3 lps bet rows. Sew sleeves in place with over-and-over sts (see respective diagrams).

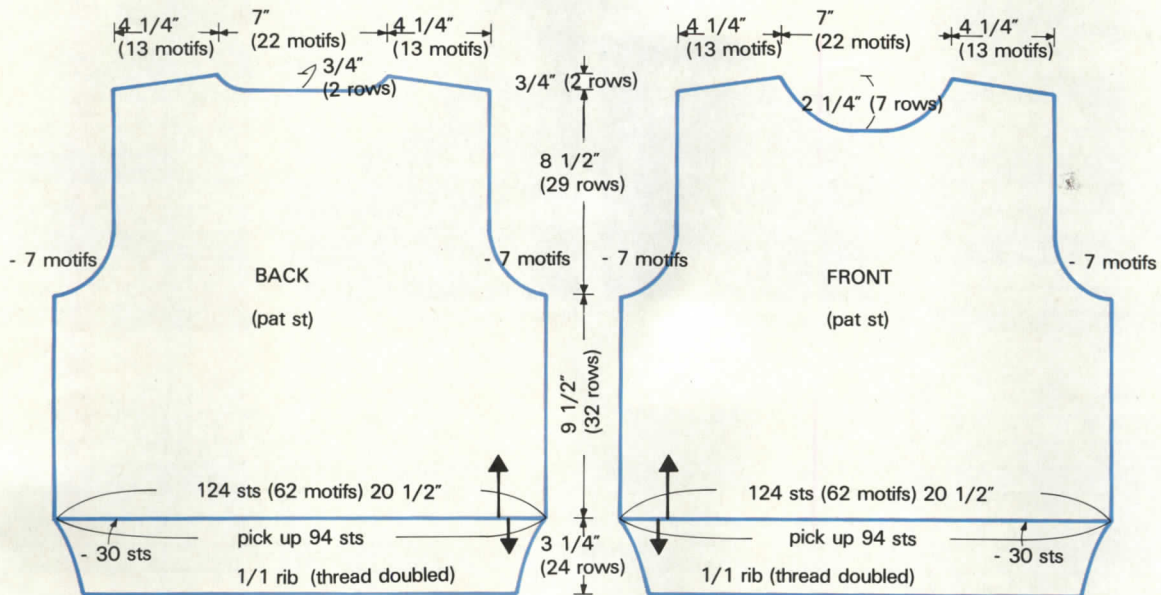
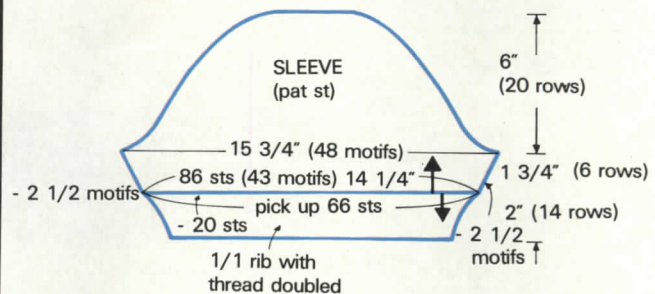

TO THREAD NEEDLE

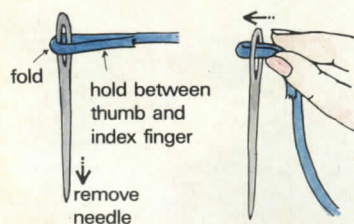

push loop thru eye of needle

TO ADD NEW COLOR

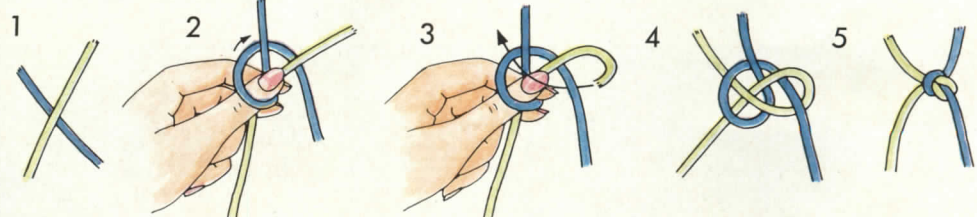

COMPLETING THE BACK

BACK

pick up sts
② rep

BACK NECK

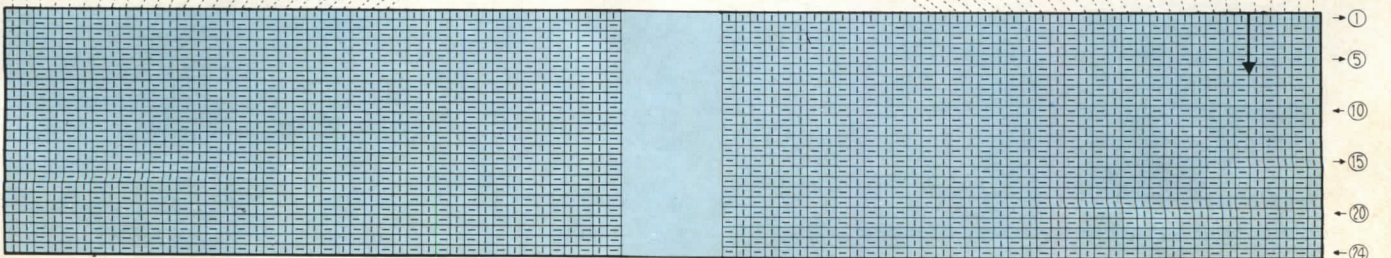
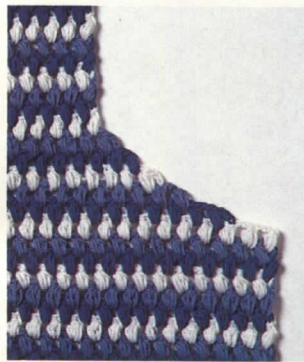
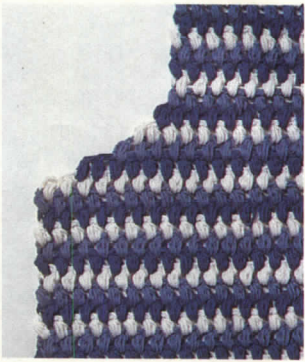
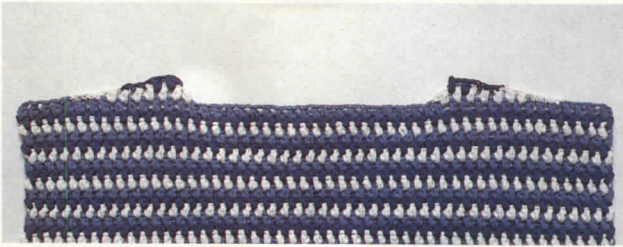
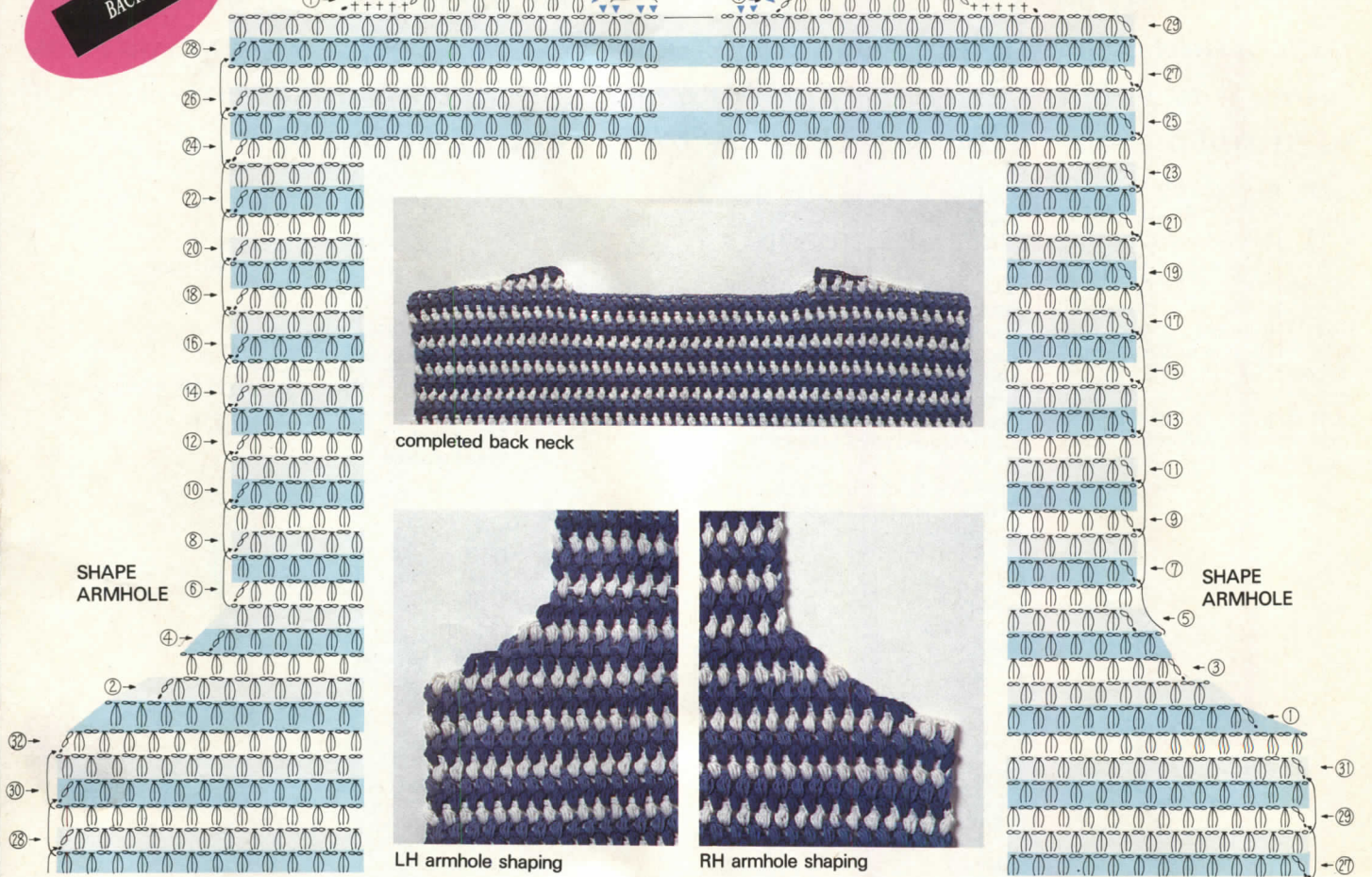

FRONT AND SLEEVES

FRONT

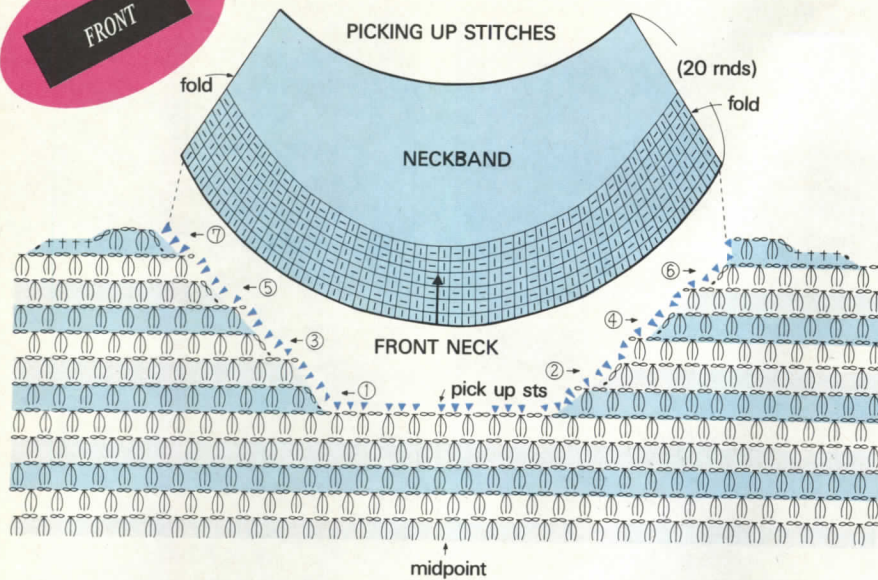

NECKBAND : 1/1 rib

back : pick up 36 sts

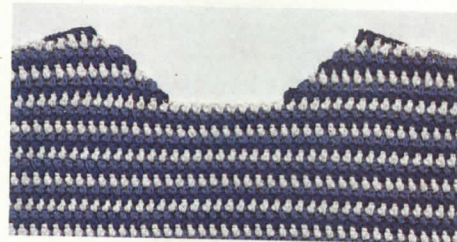
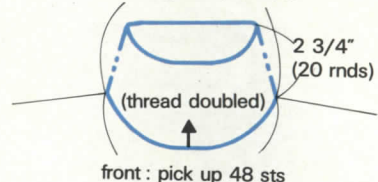

completed front neck

SLEEVE

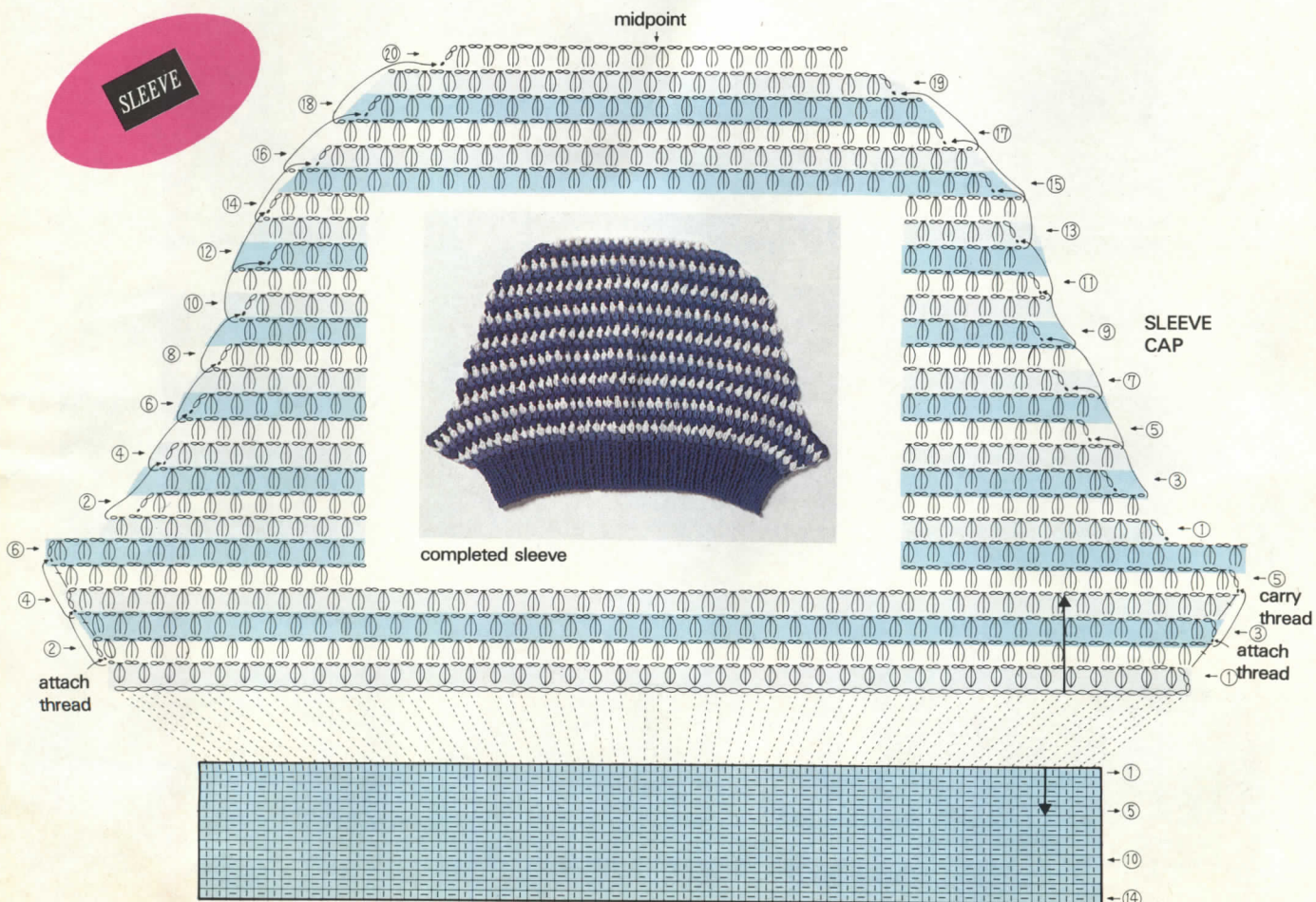

PATTERN STITCH AND FINISHING

PATTERN STITCH

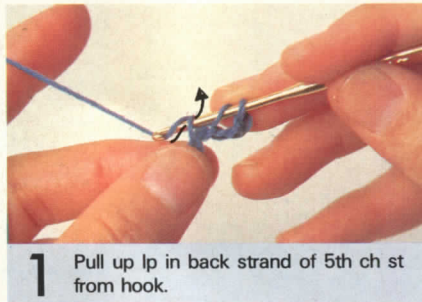
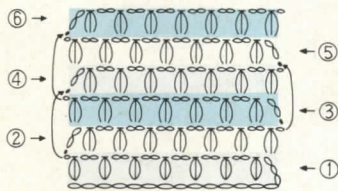

1 Pull up lp in back strand of 5th ch st from hook.

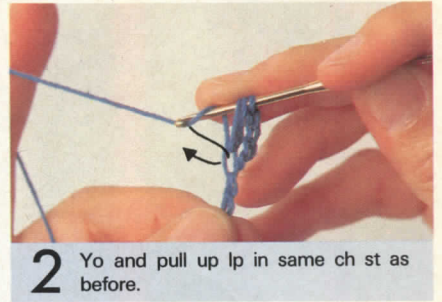

2 Yo and pull up lp in same ch st as before.

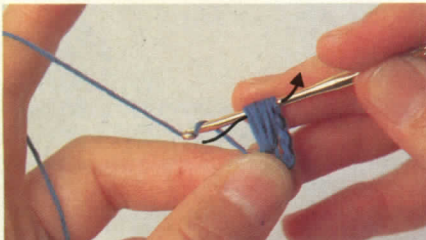

3 Work a 3rd partial hdc, yo and draw thru all lps on hook = 3-hdc cluster.

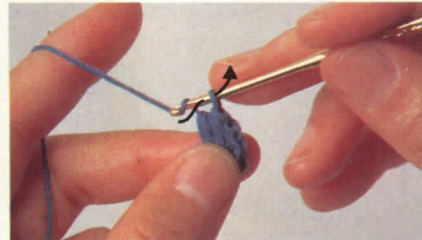

4 Work 1 ch st.

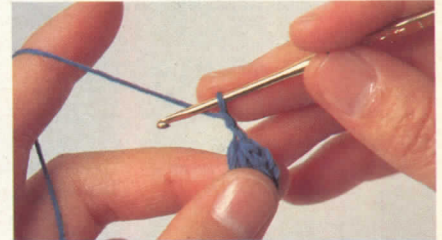

5 Work * 1 ch, sk 1 st, 3-hdc cluster (cl) in next st, 1 ch, rep from *.

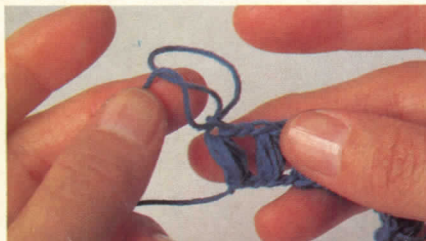

6 Pass ball thru last st to secure thread but do not cut. Drop thread.

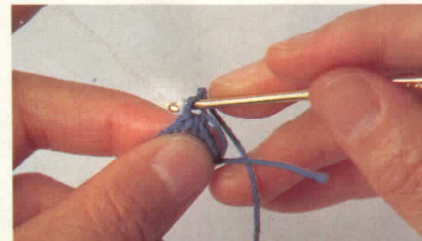

7 Turn piece and attach ecru thread with sl st, ch 2.

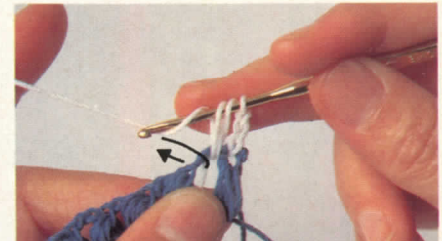

8 Holding thread fairly loosely, work 3 partial hdc over ch-2 lp.

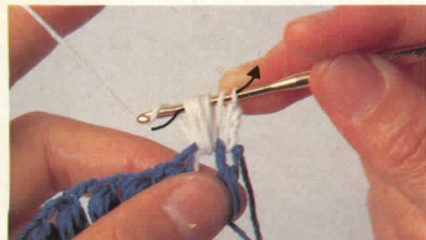

9 Yo and draw thru all lps on hook - cl made.

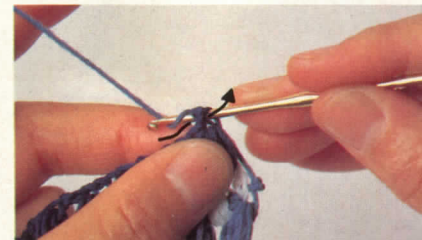

10 Row 4: pick up bluish gray thread and work same as on previous rows.



SETTING IN SLEEVES



1 RS together, pin sleeve in place all around armhole.



2 Taking 2 strands of each st on each side of seam, sew with overcast sts.



3 Make 2 overcast sts on each row: 1 in top of cluster, 1 in body of cluster.

COMING IN THE NEXT ISSUE

LEISURE STYLE



Call it a sleeveless pull-on or a vest – either way, this multi-use garment will look great with skirt or pants. And you'll pick up a new stitch while you're crocheting it: ambitious little shells climb up the ladder through all those double crochets, making it all the way to the top!

TULIP TIME

If tulips are your favorite flowers, coordinate wall hanging, pillow lace and sheet border via the blooms that have made Holland famous. When you wake up in the morning, you'll know spring is just about here.

TWO OF A KIND



All good things come in pairs and this harmonious duo will give as much pleasure to the crocheter as to the beholder.

TIME FOR A BREAK



These coasters are very pretty, but they are also fun and quick to crochet. So make as many as you want and don't forget to serve the refreshments.

THE GOOD GIFT

Popcorns create an embossed effect here, and our color filmstrip shows you exactly how to crochet the lacy chain-loop border. Chances are you'll want to use it on other projects, too.



