

YOUR FAVOURITE MAGAZINE PACKED WITH PROJECTS, INSPIRATION & EXPERT ADVICE

TODAY'S QUILTER

ISSUE EIGHTEEN

LYNNE EDWARDS MBE
answers your quilt queries!

Create beautiful quilts for your home

FRESH START!

Begin your year with Jo Avery's bold kaleidoscopic quilt

THE ESSENTIAL GUIDE
★  ★
FABRIC MARKING TOOL KIT
What you need and how to use it!
BY LINDA CLEMENTS

Rosy Outlook

MAKE OUR ROSE STAR QUILT BY CAROLYN FORSTER

JELLY ROLL DESIGN THE LINTOTTS' FABULOUS FIRECRACKER PATTERN

INTRICATE PIECING SEW A NEEDLE BOOK USING YOUR TINIEST SCRAPS

The incredible Lucy Boston

DISCOVER HER LEGACY AND HOW YOU CAN PAY TRIBUTE

LET'S MAKE 2017 THE YEAR OF THE QUILT!

New for you!

A rustic-style medallion design, Jane Austen's passion for quilting, and meet Philippa Naylor



The latest Liberty fabric!



IMMEDIATE MEDIA ^{CO}

THE atelier SERIES

These contemporary styled, well illuminated, free-arm sewing machines with easy to use computerised features are perfect to take your sewing to a new level. The larger arm space and superior feeding system ensure they are equally suited to both larger projects and precision sewing.

DESIGNED FOR EVERY TYPE OF SEWING



atelier 3

A clear LCD screen helps you select from the 120 stitches including 7 auto 1-step buttonholes and alphabet.



atelier 5

This machine has an incredible 91 needle positions and an easy change needle plate to enhance straight stitch performance at up to 1,000 spm.



atelier 7

Quilters and designers will enjoy the AcuFeed Flex layered fabric feeding system and the automatic presser foot lift for easy pivoting.

For further information:

Telephone 0161 666 6011 or visit www.janome.co.uk

The World's leading sewing machine manufacturer



SMART
ELEGANT
SOPHISTICATED



JANOME

Meet the team

Senior Editor Jenny Fox-Proverbs
Art Editor Kit Cheung
Deputy Editor Fiona Smith
Features Editor Jane Rae
Technical Editor Laura Pritchard
Digital Editor Zoe Williams
Technical Consultant Linda Clements
Group Senior Editor Julie Taylor

Contributors

Jo Avery • Ali Burdon • Lynne Edwards MBE
 • Mandy Shaw • Pam & Nicky Lintott • Anne Williams
 • Carolyn Forster • Alex Duce • Rob Eyres
 Photography Immediate Media Photo Studio
 unless otherwise stated.

Write to us

Today's Quilter, Immediate Media, Tower House,
 Fairfax Street, Bristol, BS1 3BN
 or email: todaysquilter@immediate.co.uk

ADVERTISING

Call: 0117 300 8206

Senior Advertising Manager Penny Stokes
Client Partnership Manager Beckie Pring
Senior Sales Executive Tiffany Jackson

MARKETING AND CIRCULATION

Newstrade Marketing Manager Janine Smith
Export Marketing Manager Rebecca Richer
Direct Marketing Executive Lily Nguyen

PRODUCTION

Production Coordinator Lizzie Ayre
Production Manager Rose Griffiths/Louisa Molter
Production Director Sarah Powell

LICENSING

Director of International Licensing & Syndication Tim Hudson

PUBLISHING

Publisher (Sewing Portfolio) Liz Taylor
liz.taylor@immediate.co.uk
Chairman Stephen Alexander
Chief Executive Officer Tom Bureau
Managing Director, Bristol Andy Marshall
Printed and bound by William Gibbons
Distributed in the UK by Frontline

BUYING

Paul Torre • Karen Flannigan • Corinne Mellerup

SUBSCRIPTIONS

Call 0844 249 0223 or subscribe online at
buysubscriptions.com



Immediate Media Company Bristol Limited (company number 05715415) is registered in England and Wales. The registered office of Immediate Media Company Bristol Limited is at Vineyard House, 44 Brook Green, London W6 7BT. All information contained in this magazine is for information only and is, as far as we are aware, correct at the time of going to press. Immediate Media Company Bristol Limited cannot accept any responsibility for errors or inaccuracies in such information. Readers are advised to contact manufacturers and retailers directly with regard to the price of products/services referred to in this magazine. If you submit unsolicited material to us, you automatically grant Immediate Media Company Bristol Limited a licence to publish your submission in whole or in part in all editions of the magazine, including licensed editions worldwide and in any physical or digital format throughout the world. Any material you submit is sent at your risk. Although every care is taken, neither Immediate Media Company Bristol Limited nor its employees agents or subcontractors shall be liable for loss or damage.



Immediate Media Company Limited is working to ensure that all of its paper is sourced from well managed forests. This magazine can be recycled, for use in newspapers and packaging. Please remove any gifts, samples or wrapping and dispose of it at your local collection point.



HAPPY NEW QUILTING YEAR!

The New Year has always been important to me. Growing up in Scotland means that I've always celebrated Hogmanay (New Year's Eve) with great enthusiasm, and so the New Year fills me with nostalgia. The first two weeks of January are spent wishing friends, family and colleagues the best for the year to come. I don't so much make resolutions in January, but rather wonder what the next 12 months hold in store. Life is full of surprises, some good and some not so good, but there is certainly never a dull moment. Myself, the *Today's Quilter* team and all of our talented contributors sincerely hope that we can provide you with lots of wonderful surprises throughout the year.

Wishing you an abundance of health, happiness and fabric in 2017!

Jenny Fox-Proverbs Senior Editor

PS We love to hear from you - keep in touch online, by email or by post.

Todaysquilter Todaysquilter Todaysquilter Todaysquilter

www.todaysquilter.com

Meet our wonderful contributors!



Jo Avery
COVER STAR

Jo had us at "pickle dish"! Apart from sounding fun, this vibrant block creates dynamic looking results try it for yourself on page 22.



Lynne Edwards
CATHEDRAL WINDOW

In-between answering your letters on page 31, Lynne found time to supercharge her most famous technique for our supplement!



Anne Williams
QUILT AS DESIRED

Anne left no stone unturned in her Q&A with Philippa Naylor on page 74, including Philippa's clever FMQ tips for beginners.

TODAY'S QUILTER

Create beautiful quilts for your home



22 Wow with this gorgeous design made with curved piecing



45 Clever use of fabric means you don't waste anything in this quilt



58 Sleep under a bed of roses



DON'T MISS AN ISSUE!

Make sure you receive every issue of *Today's Quilter* – delivered direct to your home address. Turn to page 56 for great subscription offers.

HAPPENING NOW

07 INSPIRED BY... Taking it slow

13 FRESH PICKS

18 DIARY DATES

GREAT READS

52 QUILTING HERITAGE

We find out more about the magical world of Lucy Boston

74 QUILT AS DESIRED

Award-winning quilter Philippa Naylor

98 JANE AUSTEN'S QUILT

Jane was an accomplished seamstress too!

WORKSHOPS

20 SHOW & TELL

Show off your quilts to us and other readers!

31 FROM THE DESK OF LYNNE EDWARDS MBE

Lynne answers some of your quilting questions

67 ESSENTIAL GUIDE

Expert Linda Clements discusses various marking tools and their pros and cons for quilting

85 BLOCK OF THE MONTH

A month in the country: celebrate the cold weather with Jo Avery's Snowflakes blocks



35
Mandy Shaw's
delightful
medallion
design

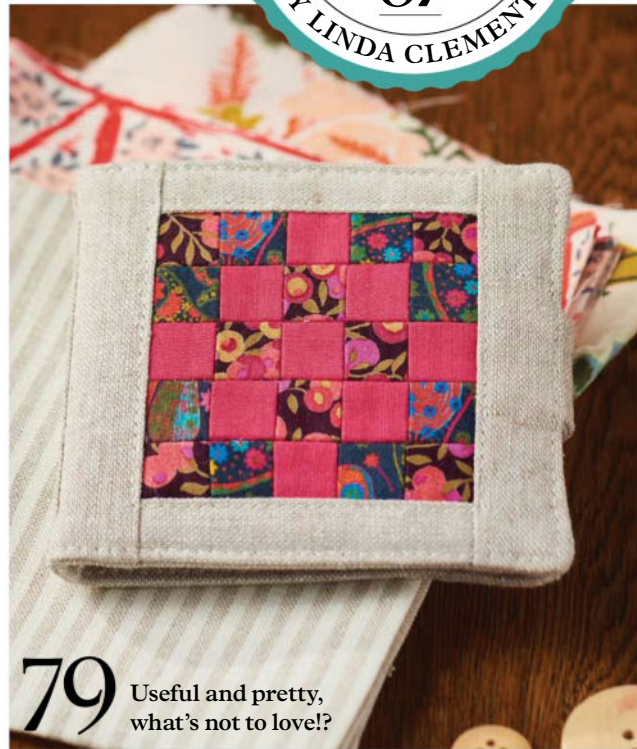

79 Useful and pretty,
what's not to love!?



85 Let it snow with Jo's
Block of the Month



13
Fresh picks:
All the latest
quilting news &
products for you

PROJECTS

- 22 PICKLE DISH DELIGHT**
Master curved piecing with Jo Avery's colourful design
- 35 RED & WHITE MEDALLION**
Try different techniques in this charming pattern
- 45 FIRECRACKER**
Use up every piece of your Jelly Roll for the front and back of our project
- 58 THE ROSE STAR**
Make this stunning one-patch quilt
- 79 HALF-INCH NEEDLE BOOK**
Personalise for friends and family

PLUS

- 03 WELCOME**
Meet the Editor, Jenny Fox-Proverbs
- 12 FREE GIFT**
What's inside Lynne Edwards' Cathedral Window supplement
- 56 SUBSCRIPTION OFFERS**
Try our free trial of our digital subscription!
- 89 TEMPLATES** For the projects
- 97 DIRECTORY**
A useful guide to companies featured
- 99 NEXT ISSUE**
What to look forward to in issue 19!



74 Anne Williams chats
to Philippa Naylor

MEASUREMENTS NOTE

Either metric or imperial measurements (sometimes both) are included in each project, as per the designer's preference. Converting measurements could interfere with cutting accuracy. Follow the same units of measurement throughout; do not mix metric and imperial. Read the instructions all the way through before cutting any fabric. Always make a test block before embarking on a large project.

THE SPRING QUILT FESTIVALS 2017

ARDINGLY

27 - 29 January 2017

Norfolk Pavilion, ARDINGLY, Haywards Heath, West Sussex RH17 6TL

Advance ticket deadline: 13 January 2017

 Find Us on Facebook
www.facebook.com/grosvenor

DUXFORD

3 - 5 March 2017

Conservation Hall, Imperial War Museum, Duxford, CAMBRIDGE CB22 4QR

Advance ticket deadline: 17 February 2017

EDINBURGH

17 - 19 February 2017

Lowland Hall, Royal Highland Centre, Ingliston, EDINBURGH EH28 8NB

Advance ticket deadline: 3 February 2017

Edinburgh Special ticket offer:
see website or ring for details

NEW SHOW HARROGATE

24 - 26 February 2017

Exhibition Hall 2, Great Yorkshire Showground, HARROGATE HG2 8NZ

Advance ticket deadline: 10 February 2017

EXETER

31 March - 2 April 2017

Westpoint Exhibition Centre, EXETER EX5 1DJ

Advance ticket deadline: 17 March 2017

- * **RADIANCE CHALLENGE 2015: MIRROR IMAGE** by Radiance Quilters – Longarm Learning Curve
- * **SASHIKO FROM SCOTLAND** by Susan Briscoe's Students
- * **THE FABRIC & FIBRE OF NATURE** by Karen Lane
- * **AN ONGOING JOURNEY** by Annelize Littlefair
- * **PAISLEY RENAISSANCE** by Sandie Lush
- * **QUILTING MY GUILTY PLEASURE** by Diane Abram
- * **ALCHEMY** by Gilli Theokritoff
- * **JOURNAL QUILT CHALLENGE 2017: Let's Dance**
- * **SOUTH WEST QUILTERS' CHALLENGE: UP, UP AND AWAY** (Exeter only)
- * **MADE IN CORNWALL** by Cornish Members of South West Quilters (Exeter only)
- * **ENCHANTED ISLANDS** by Exe Valley Quilters (Exeter only)

All displays are subject to change



Above: 'Nature's Treasures' by Diane Abram



Left: 'Art Deco Study 1' by Roz Rossiter (Radiance Quilters)



Above: Detail of 'When Rainbows Dance' by Annelize Littlefair



Left: 'David' by Gilli Theokritoff



Above: 'Yellow Poppies' by Karen Lane



Right: 'Melin Wynt (Windmill)' by Sandie Lush

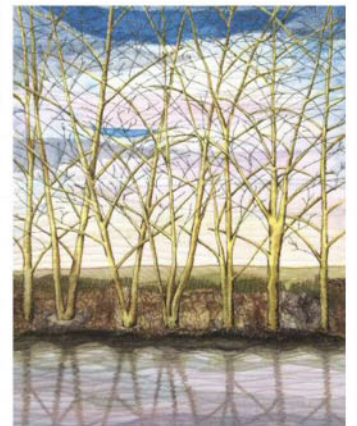

Above: 'Riverside Trees' by Karen Lane

QUILTING SUPPLIERS STANDS

Shop with all of our dedicated patchwork exhibitors. Fabrics, books, sewing machines and notions to cover all your needs.

WORKSHOP PROGRAMME

Participate in our workshops by quilting experts.
Telephone for a list or download from the website. (Not available at Ardingly)

* OPEN 10am-4.30pm (4pm Sunday) * FREE CAR PARKING * DISABLED ACCESS * RESTAURANT

BUY YOUR TICKETS IN ADVANCE & SAVE MONEY! BOOK ON-LINE, BY POST OR BY PHONE*

Advance Tickets: Adults £7.00, Senior Citizens £6.00, Children (8-16) £2.00

On The Door: Adults £8.00, Senior Citizens £7.00, Children (8-16) £3.00

ENQUIRIES: Grosvenor Shows Ltd, 282 High Road, Whaplode, Spalding, Lincolnshire PE12 6TG
Tel: 01406 372600 & 01406 372601 Fax: 01406 372602 E-mail: grosvenorshows@btconnect.com

Office Hours : Mon - Fri 9.00am - 5.00pm Website: www.grosvenorshows.co.uk

*All card bookings are subject to a 50p booking fee Deadline for advance ticket bookings: 2 weeks prior to the show

INSPIRED BY..

Taking it slow

TQ

Slow down and
find inspiration
in small
things



THE DESIGNER

JANE SASSAMAN

Exuberant designer and quilt artist Jane Sassaman's work has been described as "William Morris on antidepressants", which is true both of her fabric collections for FreeSpirit Fabrics and of her quilts. Illinois Album, for example, is a celebration of the vibrant life in her northern Illinois home. Depicting some of the characters that frequent her property, this ornate appliqué and machine embroidered quilt is an impressive expression of Jane's love of nature. Enjoy more of her work at www.janesassaman.com

Explore Jane's
forthcoming
fabric collection
Scandia, at www.freespiritfabrics.com



TQ
A hybrid of tiny scraps creates intriguing patchwork



Preserving History will be on sale in the UK from 26th January

THE BOOK

PRESERVING HISTORY

Here at *Today's Quilter* we are always drawn to quilts with a rich heritage. For that reason, we can't wait to batten down the hatches and enjoy the 14 beautiful projects on offer in this rather lovely book. Julie Hendrickson, an avid collector of antique quilts, shares her knowledge and love of these old treasures to teach us how to make wonderful reproduction quilts of our own. With a special focus on how these quilts were quilted and finished, it's a library must-have for any antique patchwork lover.



TQ
When it comes
to textiles,
the more the
merrier!



THE SHOP

DEBENHAMS

Winter is the perfect time to indulge in our favourite crafts during slow mornings and cosy nights in. Even our favourite high-street stores have been inspired by this sentiment so pom-poms, knits, tassels and quilting are all the rage at Debenhams this season. We love the hand quilting and hand-tied effect of the Cream Tasselled throw from Matthew Williamson, giving any bedroom a crafty handmade feel. www.debenhams.com

We love the pops of colour in the Cream Tasselled throw, £100. Find it at www.debenhams.com

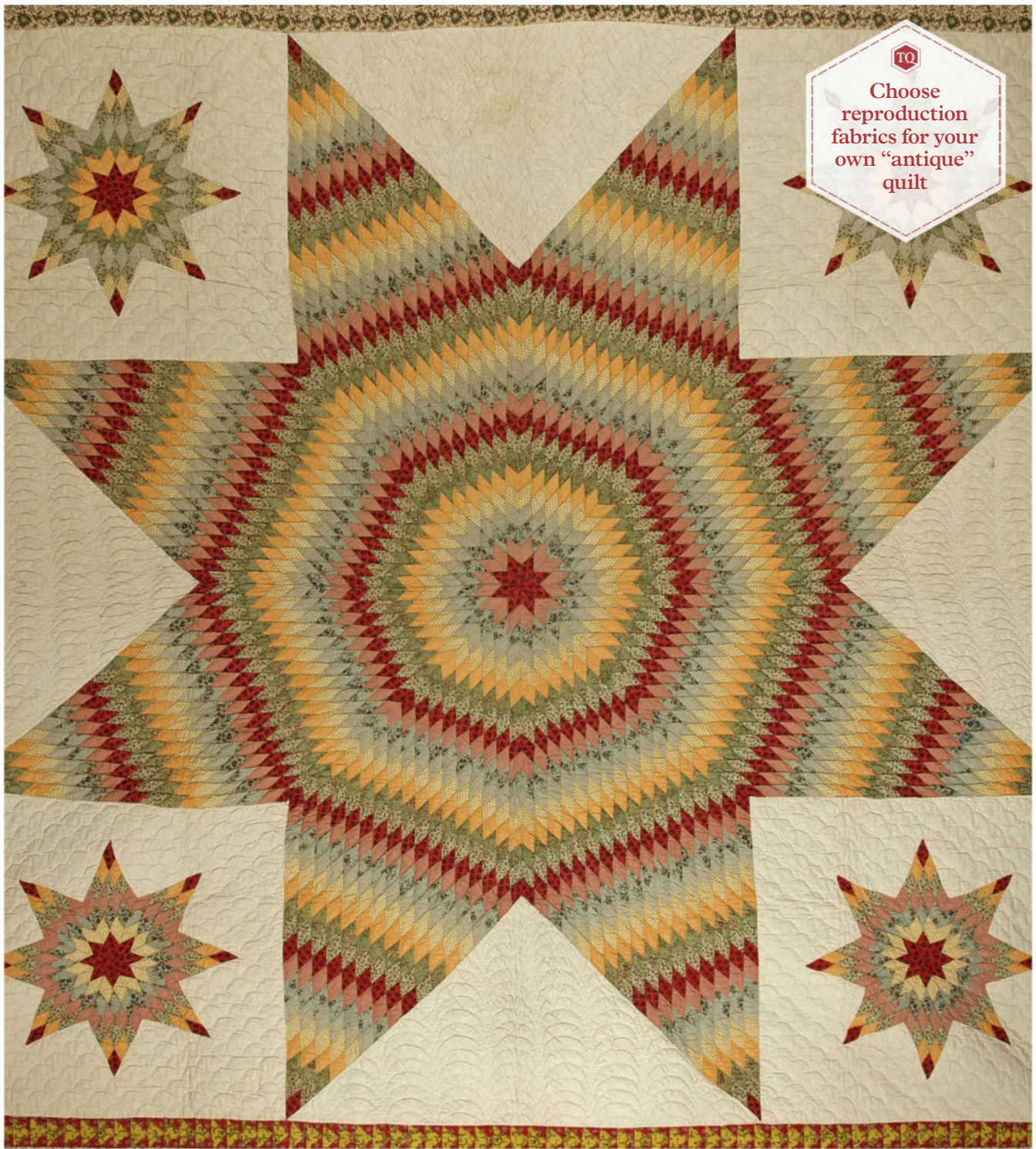

Choose
reproduction
fabrics for your
own “antique”
quilt



THE QUILT

STAR OF BETHLEHEM

Courtesy of the American Museum in Britain (Bath, UK), is this striking hand-pieced quilt c1835. Its well coordinated colours and neat piecing make this an outstanding example of a star quilt. The eight-pointed star in the centre of the quilt is made from rows of diamonds pieced in alternating bands of colours and appliquéd onto a white background. While rotary cutting techniques would now make a similar quilt easier to achieve, we've been inspired to take pleasure in the traditional slower methods of piecing.

The American Museum in Britain has a stunning display of quilts and textiles from the eighteenth to mid-twentieth century www.americanmuseum.org

Sewing QUARTER

WATCH IT • LOVE IT • SEW IT



I'm delighted to announce the launch of a brand new way to enjoy quilting! **Sewing Quarter** is *Today's Quilter's* new sister TV channel, dedicated entirely to quilting and sewing.

Tune in to Freeview channel 78 in January for the launch of Sewing Quarter! Their packed schedule means you can watch some of

your (and my!) favourite quilting experts demonstrating techniques to help you improve your craft no matter what your skill level. I'm also excited about their bespoke kits that contain everything you need to create gorgeous quilts, cushions and bags. The shows are packed with hints and tips to ensure you're ready to get started as soon as your kit arrives. I've been working closely with Sewing Quarter to help them bring you the

fabrics, tools, patterns and kits I know you want and need. In fact, you might even see yours truly popping up on your screen occasionally...

As well as trusted brands such as Olfa, Janome, Aurifil and FreeSpirit Fabrics, Sewing Quarter will also be offering their very own quilting products. Now you can quickly and easily find everything you need in one online shop, leaving you even more time to quilt.

Sign up to the Sewing Quarter's mailing list at www.sewingquarter.com/freepattern to be kept up to date with pre-launch news. Then find the remote control, pop the kettle on and prepare to enjoy this amazing new channel created just for you!

Jenny

Jenny Fox-Proverbs
Senior Editor

Meet the presenters

You'll soon get to know the inspirational presenters who adore sewing as much as we do. **Natasha McCarty** grew up learning sewing skills from her grandmother and still uses her grandmother's sewing machine today! I know she's looking forward to sharing her love of sewing with you on the channel. **John Scott** has a passion for all things fabric and tells me that he can't wait to show us the beautiful fabric collections Sewing Quarter has in store.



Natasha McCarty



John Scott



Download your
FREE pattern today!

If like me you can't wait to tune in, go to the Sewing Quarter website to be the first to receive all the latest news. You can even download a FREE quilt pattern, usual price £7.99!

www.sewingquarter.com/freepattern





Free Gift

WINDOW TO THE WORLD

Lynne Edwards shares her new technique for making gorgeous and oh-so clever Cathedral Window quilts!



LET US KNOW!

Drop us a line – an email, letter, tweet or Facebook post – letting us know about your quilting. Whether it's a new project, treasured heirloom, favourite fabric or imaginative mood board, we'd love to see what you've been up to and hear your stories!



CLICK HERE FOR YOUR FREE GIFT!

LIKE MANY OF you, here at *Today's Quilter* HQ we're always excited to learn something new that can broaden our quilting repertoire and build new skills. So we were thrilled to work with Lynne Edwards MBE on our latest supplement. Talented, funny and generous with her extensive quilting knowledge, Lynne shares with you her new technique for making Cathedral Window blocks. Yes, ingenious Lynne has worked out a way to make this clever technique easier and quicker, so anyone can master it!

Within the 44 pages, Lynne shows you step by step how to master her new Cathedral Window technique, giving you all the info and tips you need to sew with confidence. Just like being in one of her classes, she guides you through the basics, and then gives you five fabulous projects on which to test out your newly-gained skills.

To begin with, she shows you how to turn the simple four-square block you've just made into gorgeous cushions and a handy carrying case. Then she moves on to something a bit bigger, with her everlasting quilt that can literally be added to forever – rather handy since these blocks can be quite addictive!

If you prefer to stick to smaller designs, Lynne's Christmas table runner is absolutely stunning, and sure to impress at this year's festivities. But why just make one, when you can stitch several for any occasion!? Finally, she shows you how to make a beautiful wall hanging, perfect for showing off some of your favourite fabrics.

So put the kettle on for a brew, sit down and learn how to create something gorgeous with this new technique.

WRITE TO US Today's Quilter, Immediate Media, Tower House, Fairfax Street, Bristol, BS1 3BN. **EMAIL:** todaysquilter@immediate.co.uk

Todaysquilter Todaysquilter Todaysquilter Todaysquilter

All the latest quilting news

FRESH PICKS

There is a literary theme this month as we find new fabrics inspired by Robert Louis Stevenson and the best-selling children's book *Guess How Much I Love You*

INSPIRATION

Sharing is caring



Almost a decade ago, two friends began posting a photo from each of their mornings on their blog, 3191 Miles Apart, named for the distance between their homes. The results are a lovely collection of crafts to make, seasonal recipes to try and inspiring ideas. *A Year Between Friends: 3191 Miles Apart* by Maria Vettesse and Stephanie Barnes Abrams, £14.99 www.abramsandchronicle.co.uk

ECO-FRIENDLY POUCH

Good to go



This sturdy little pouch part of a set of two by Diane K Knott is made from recycled plastic that is tough enough to handle sharp-edged quilting and sewing tools and large enough to carry all that you need for quilters on the go. The set includes two zip-top pouches: large 9½in × 7in pouch featuring the Crazy Daisy quilt image, and the small 8½in × 5in pouch featuring the Vintage Village image (shown here). £8.99

www.searchpress.com



NEW LIBERTY PRINTS

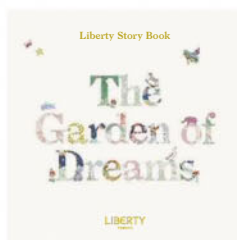

GARDEN OF DREAMS

Once upon a time there was a magical world beneath the flowers and leaves, where tiny creatures played hide and seek, and ate miniature picnics atop toadstools. Liberty fans will love this new collection of 16 original fabrics based on the poems of Robert Louis Stevenson's much loved *A Child's Garden of Verses*. The collection is separated into four visual stories: Fairy Land, My Garden Grows, Little Treasures and Land of Dreams featuring fairies, flowers, summer blooms, dancing kites and so much more. £22.50 per metre. www.libertylondon.com

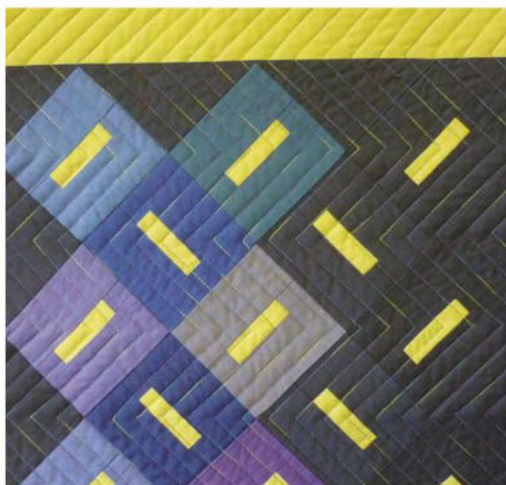

TOTES AMAZING

NEW BAG KITS FROM OAKSHOTT

Helen Butcher from Little Patch Pockets has designed three clever new patterns showcasing Oakshott's lovely Lipari range of fabrics. Choose from Jacob's Ladder (£38.00), En Pointe (£32.00) and Needles & Pins (£32.00). The finished size is W10inx H14inx D3in and each kit contains fabric and instructions. www.oakshottfabrics.com



QUILT AS YOU GO

Sew Easy

Award-winning quilter Gina Perkes' new book shows us how to appliqué and quilt at the same time using her "Appli-Quilting" technique. All of this can be achieved on a domestic machine or on a longarm machine. She provides lots of useful advice about appliqué methods, choice of threads and stitches, setting up your machine, and also includes six projects to get you started. Learn how wash-away sheets, secondary quilting designs, couching and bobbinwork can take your designs to the next level.

£21.99 www.searchpress.com

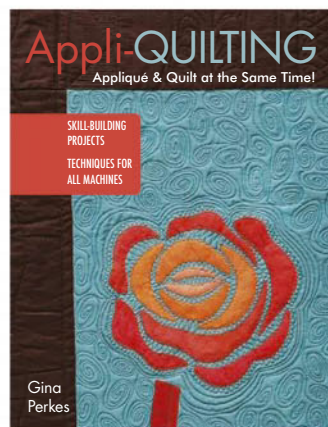

ON THE EDGE

Trimits Rulers

These rulers will make measuring and cutting so much easier!

Trimits aluminium rulers have a strong non-slip base and are available in 30cm or 40cm lengths with centimetre and millimetre markings. From £6.99.



The Trimits transparent ruler with stainless edge helps prevent damage when cutting with rotary cutters or knives. This ruler is graduated in metric and is 30cm long. £6.



For stockist information, email groves@stockistenquiries.co.uk

HANDY TOOL

Supersize 5-in-1 Sliding Gauge



Clover's new Nancy Zieman tool doubles as a T gauge and as a large compass. It can be set at increments of 3.2mm (1/8in) making it ideal for accurate spacing and marking and you can also draw out circles in various sizes. With a radius of 11 inches there's a lot of scope for upsizing! £17.50

For stockist information, email clover@stockistenquiries.co.uk or call 01453 883581

Stitch to your heart's content in a rainbow of colours



TOP KIT

THE 80WT IS HERE!

If you were lucky enough to attend the International Quilt Market in Houston last year you'd have seen the official launch of Aurifil's brand new 80wt thread! Yes, you read that right, 100% cotton 80wt thread from Aurifil is here! Aimed at those who like free-motion quilting, machine embroidery, free-motion couching, English paper piecing, hand appliqué, machine appliqué and more, this will be your go-to thread. Wound on cherry wood spool bases, the 80wt comes in a total of 88 colours. With recommendations like this one from Carolyn Friedlander, "The 80-wt is exactly what I've been wanting – it's thin, strong and totally disappears in your work", we're willing to give it a try! www.aurifil.com



ACCESSORIES

Sew Easy Mini Templates

Cut with accuracy and consistency every time with these mini squares and right-angled triangle templates. Each set has eight clear templates (0.75in-3in) with an inbuilt 1/4in seam allowance and marking points. The clear transparency of the durable acrylic template makes fussy-cutting a breeze. These new templates complement the existing pentagon, diamond, triangle and hexagon geometric shapes. £15.99
For stockist information, email groves@stockistenquiries.co.uk





GUESS HOW MUCH I LOVE YOU

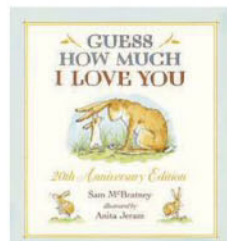

CELEBRATING A CHILDREN'S CLASSIC

This delightful new fabric line celebrates the popular children's story of two Nutbrown Hares written by Sam McBratney with the gorgeous illustrations of Anita Jeram. *Guess How Much I Love You III* from Clothworks includes five main prints featuring the star characters from the book – Little Nutbrown Hare and Big Nutbrown Hare – and coordinating stripes, spots and words. Available in a colour palette of soft pinks, blues, greens and creams, the collection is ideal for all sorts of accessories for baby nurseries to children's room and clothing.

www.egsuk.com www.clothworks.com www.walker.co.uk



"PASTA" PUZZLER

Design matters

Muriel Higgins' *Puzzle Quilt Colouring Book* explores quilt designs where the construction is hard to understand and can sometimes seem impossible. Using her PASTA technique "PArT Seam Then Across" she opens up a whole world of design possibilities. The b/w grids are left blank for you to colour in and create your own quilt designs and Muriel includes a section on "using the technique" explaining the "P" seam. Hours of fun! £7 + p&p, Print on demand from lulu.com

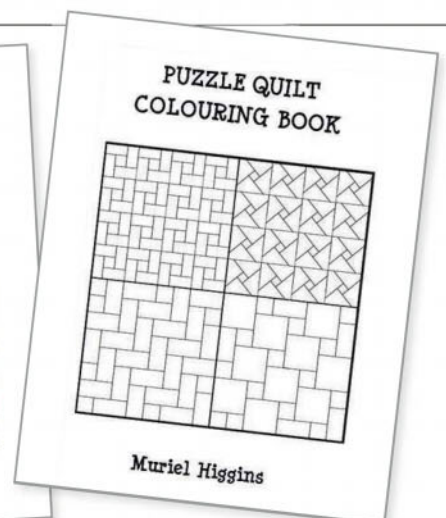
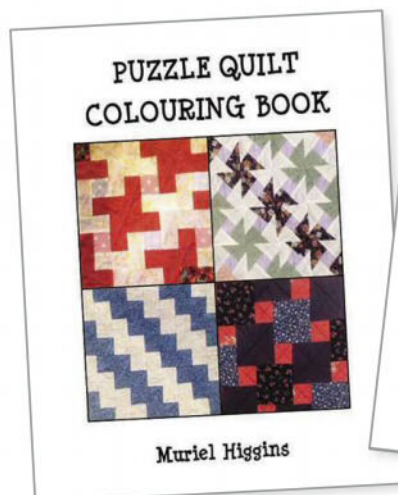



WIN
For your chance to win a set of these templates and ruler foot, turn to page 20



CREATE

RULE YOUR QUILTING

The Cotton Patch is delighted to be selling the acclaimed Westalee Ruler Foot and Templates. Designed by Leonie West, the Westalee Ruler Foot allows quilters to expand their creativity by stitching with the guidance of a template (ruler) on their own domestic machine. The key to the system is the Westalee Foot, a half inch ruler foot that opens up a world of creative designs that were once only achievable on longarm quilting machines using the wide variety of Westalee rulers and templates. In order to cater for the variety of domestic machines on the market, there are a number of different foot options and template thicknesses available. To help quilters understand the system and what is required, The Cotton Patch has produced an eBook, which is available to view from the Westalee Ruler tab on their website. The eBook contains videos explaining how the rulers work along with information on other useful tools to aid or improve quilting with rulers. For more info, call 0121 778 5327 or visit www.cottonpatch.co.uk



JOIN IN

Celebrate a literary icon

This year will mark the bicentenary of Jane Austen's death and many events are planned to mark this at the Jane Austen's House Museum, located in the charming village of Chawton, Hampshire. One project the Museum will be embarking upon is the construction of a story quilt, which will tell the story of Jane's life and writings. It will be composed of squares, each one being produced by a different group – they hope to include local schools, organisations and quilting groups from around the world. Turn to page 98 to read more about The Jane Austen Quilt, made by Jane, her sister and mother. For more information about this project, please contact the Museum via enquiries@jahmusm.org.uk

LIBRARY ESSENTIALS

Explore collage and free motion quilting

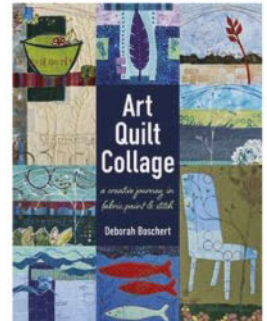

Art Quilt Collage
Make a series of treasured art quilts from fragments of cloth, stitched motifs and painted details with guidance from award-winning art quilter Deborah Boschert. £19.99 www.searchpress.com

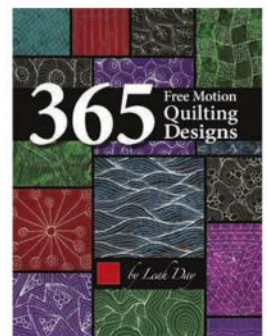

365 Free Motion Quilting Designs
Get 2017 off to a flying start with this new book from Leah Day that provides a design for every day of the year. There is also a video tutorial for every design in the book. £26.99 www.searchpress.com

Don't forget Sewing Quarter, the new channel dedicated to quilting and sewing, launches this month on Freeview channel 78. Sign-up now & you'll get all the info, plus choose a FREE downloadable pattern – our usual price £7.99! www.sewingquarter.com/freepattern

What to see and do now

DIARY DATES

Treat yourself to a wonderful day out at an inspiring quilting or textile exhibition. See what's on around the country with our handy listings guide

QUILTING EXHIBITIONS

Village Green Quilters' Exhibition & Fabric Sale

15th January, Surrey
 ● A fun day hosted by several local quilt groups and featuring over 40 stalls selling fabric, books and related items. There will be a fantastic range of contemporary, art and traditional quilts.
 Farnham Maltings, Bridge Square, Farnham, Surrey, GU9 7QR
 10:00-16:00
 Call 0125 274 5444
www.villagegreenquilters.co.uk
www.farnhammaltings.com

Patchwork for Pleasure

4th February, Nottingham
 ● Biennial exhibition of patchwork quilts and smaller items celebrating the work of Nottingham Quilters. Sales table, tombola, workshops, refreshments.
 St Andrews Church, Mansfield Road, NG3 5AD
 10:00-16:00
 Admission: Free
www.patchworkforpleasure.co.uk

Spring Quilt Festival

27th-29th January, Ardingly, Sussex

Spring Quilt Festival

17th-19th February, Edinburgh, Scotland

Spring Quilt Festival

24th- 26th February, Harrogate, Yorkshire

● Wonderful displays of quilts upstairs, while downstairs we have all your favourite patchwork and quilting suppliers. You can also meet the experts to "show you how". Facilities include restaurant, disabled facilities, easy access, free parking.
 Admission: £8.00
www.grosvenorshows.co.uk

Quiltfest 2017 (Region 13, The Quilters' Guild of The British Isles)

Wales
 ● Various dates in February There's a full programme of events to enjoy at this year's Quiltfest at two venues!



Opus Anglicanum: Masterpieces of English Medieval Embroidery, at the V&A until 5 February 2017. Support generously provided by The Ruddock Foundation for the Arts. Supported by Hand & Lock. vam.ac.uk/opus

8th-19th February

On the Edge

● Collection of quilts from 2016 Contemporary Quilt, a specialist group of The Quilters' Guild.
 Royal International Pavilion, Abbey Road, Llangollen, LL20 8SW
 10:00-16:00 daily

1001 Nights

● Textile challenge with Kazakhstan fabrics.
 Royal International Pavilion, Abbey Road, Llangollen, LL20 8SW

12th February

Trading Day at the Royal Pavilion!

● Light refreshments available
 Royal International Pavilion, Abbey Road, Llangollen, LL20 8SW
 Admission: £3.50

1st-28th February

Wrexham Tailors' Quilt Challenge

● Region 13 of The Quilters' Guild display of quilts inspired by this work.
 Museum and Art Gallery, Parade Street, Llangollen, LL20 8PW
 13:00-16:00 daily

8th-19th February

Miniatures

● Display of Miniature quilts from The Quilters' Guild specialist group.
 Museum and Art Gallery, Parade

Street, Llangollen, LL20 8PW

10:30-16:00 daily

www.quiltfest.org.uk

TEXTILES

Revolutionary Textiles 1910-1939

Until 29th January, Manchester
 ● Among the works featured in this exhibition are fabric lengths, garments and samples designed or produced by the Omega Workshops, Paul Poiret, Raoul Dufy, Barron and Larcher, Crysède, Josef Hillerbrand, Ruth Reeves, Marion Dorn, and Bauhaus-trained Otti Berger.
 The Whitworth, The University of Manchester, Oxford Road, Manchester, M15 6ER
www.whitworth.manchester.ac.uk

Opus Anglicanum, Masterpieces of English Medieval Embroidery

Until 5th February, London
 ● Discover the luxury and artistic embroideries that England was famed for from the 12th to 15th centuries, and that were sought after by kings, queens, popes and cardinals across Europe.
 V&A, Cromwell Road, London, SW7 2RL
<https://vam.ac.uk>



Top, Early Flight by Brenda Walker (SWG Challenge); Above, Floribundance by Gilli Theokritoff, both from the Spring Quilt Festivals

INTERNATIONAL

Tokyo International Great Quilt Festival

19th-25th January, Japan
www.tokyo-dome.co.jp

Stepping Stones Quilters Annual Quilt Show

26th January-4th February, Bahamas
 Trinity Methodist Church, Frederick Street, Nassau
 10:00- 1:00 daily, including Sunday
 Admission: Free
 For further information, contact susan-hope@hotmail.co.uk

LET US KNOW!
 Drop us an email to Today'sQuilter@immediate.co.uk telling us about your upcoming quilting events

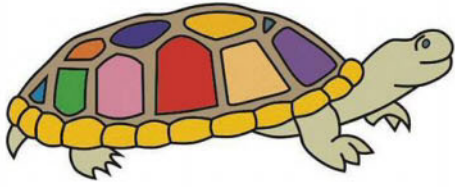

Threads and Patches

Award-winning Patchwork and Quilting Shop

15 Watling Street, Fenny Stratford, Bletchley MK2 2BU • 01908 649687

WE SELL



JANOME

Lewis & Irene
Threaded with love

Glover



Quinn
MADERA



**WEEKLY
SPECIAL DEALS
ONLINE**

Join our mailing list

**FABRIC PANELS
GALORE**



**SPECIAL DAYS OUT AT
THREADS AND PATCHES**

Bring your group for a day to remember, demonstrations, lunch and shopping!

WORKSHOPS AND CLASSES DAILY

see online for details

WWW.THREADSANDPATCHES.CO.UK

FREE

UK POSTAGE
OVER £30



Join in and be part of our community

SHOW & TELL

The only thing better than putting the finishing touches to your latest quilt is showing it off! So let's see what you've been up to this month...

WRITE TO US

Today's Quilter,
Immediate Media, Tower
House, Fairfax Street,
Bristol BS1 3BN
EMAIL: todaysquilter@immediate.co.uk



TQ *Project of the month*



Scenic sewing

I moved to Cornwall near Marazion when I retired and wanted to do a patchwork/collage of St Michael's Mount, so here it is. I used a quilt-as-you-go technique, adding embroidery and beads. I was very pleased with it having only done patchwork since retiring. Then, this summer I went to Birmingham and was inspired to do a second one using a narrow strip style.

Carol Brown, via email

Both your quilts are gorgeous Carol. What a great way to preserve a scenic memory!

Seasonal inspiration

I thought I would send you a photo of my completed lap quilt. I used Jo Avery's spring seasonal cushion from issue 7 as an inspiration. I've not done a lot of needleturn, preferring blanket stitch appliqué in the past, but I really enjoyed doing this as a gift.

Beverley Major, North Yorkshire

Thanks for the letter and picture Beverley, we really like how you took the cushion idea and adapted it for a lap quilt. We hope you enjoy the other cushions in the series as much.



The COTTON PATCH
The One-Stop Patchwork & Quilting Shop

WIN: The best letter each month will get a Westalee Ruler Foot and Sampler Template Set, worth £120

Create a wide variety of designs on your domestic machine at home with the Westalee Ruler Foot and template set, now available from The Cotton Patch. Each issue, one lucky winner will receive a Westalee Ruler

PRIZE WORTH £120

Foot for their specific machine make, plus Sampler Template Set 1, which includes six templates, worth £120 from The Cotton Patch. www.cottonpatch.co.uk

From the heart

This is my hearts quilt, as featured in issue 16.

I made it for a very special daughter-in-law who had just undergone a massive amount of surgery for cancer. Called "Loving Hearts" I quilted with overlapping hearts and I hope that she gained comfort using it during her recovery from surgery. Sadly, she lost her battle in August. I now intend to use the other half of the Jelly Roll to make a



second heart quilt so that my granddaughters can have one each to keep in her memory.

Sue Oakley, via email

We're so sorry to hear your loss Sue. Your idea of giving a quilt to each granddaughter in their mum's memory is really special.

A BRAND NEW MAGAZINE!

PAPERCRAFT * PRINT & FONT MAKING * HYGGE * BOOKS * YOGA

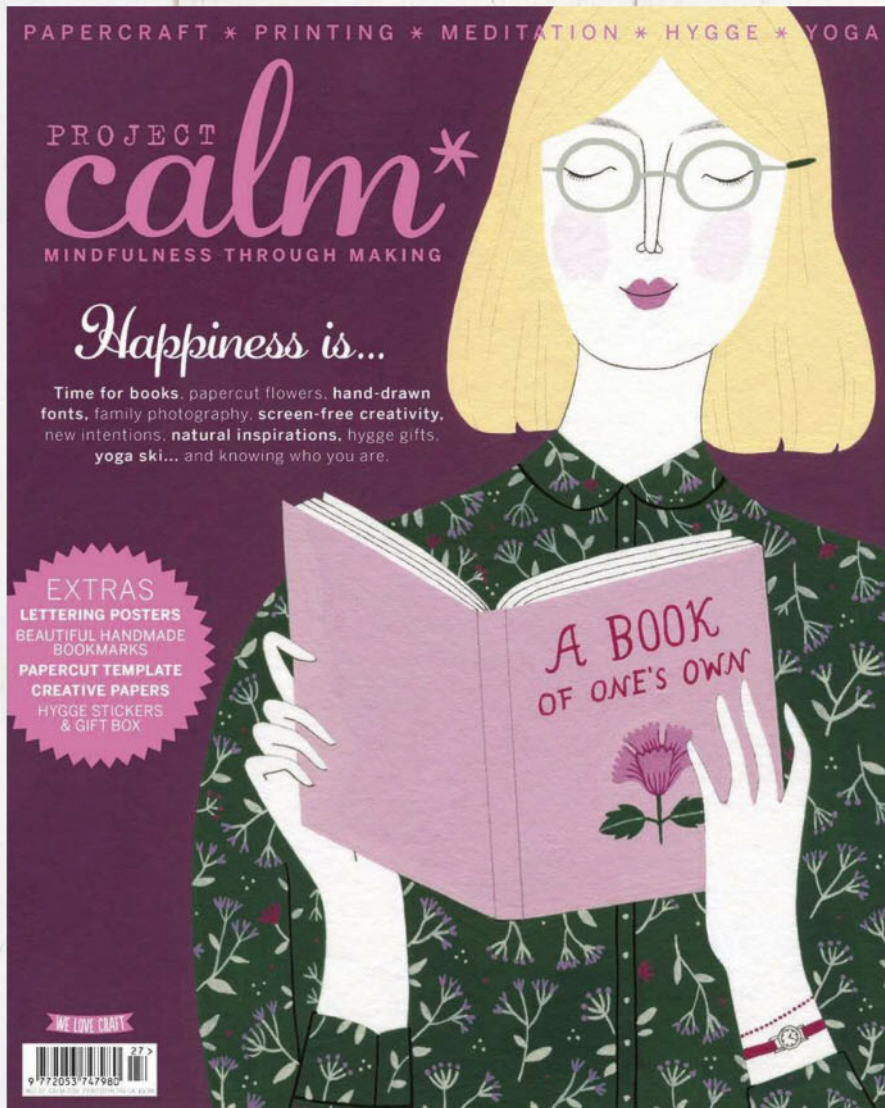

Welcome to a brand new magazine filled with quality writing, beautiful photography and new ideas to try. At home or away, indoors or out, discover mindfulness through making.



£9.99*
WINTER 2016

EXTRAS IN THIS ISSUE INCLUDE...



Beautiful handmade bookmarks



Hand-drawn word prints



Pretty & unique gift box template



Papercutting template & print



Thank yous & gift tag stickers

ORDER YOUR COPY TODAY

ORDER ONLINE WWW.BUYSUBSCRIPTIONS.COM/CRAFTSPECIAL
OR CALL 0844 844 0388 AND QUOTE 'PROJECT CALM 2'

Lines open weekdays 8am to 8pm and Saturday 9am to 1pm. Overseas please call +44 (0) 1795 414 676.

* EUR price £11.99, ROW price £12.99. All prices include P&P. Please allow up to 28 days for delivery.





FOUNDATION PIECING PROJECT

PICKLE DISH DELIGHT

Are you ready for some more spikes and curves? This traditional quilt design looks amazing in highly-patterned fabrics with just a hint of white to highlight the “pickles”.

Designed and made by **JO AVERY**



PICKLE DISH DELIGHT



You will need

- Varied patterned fabrics – 4yds in total
- Spike background fabric (red) – 1¾yds
- Spike fabric (white) – 1¾yds
- Inner border fabric – 15in x WOF
- Outer border fabric – 25in x WOF
- Batting – 74in square
- Backing fabric – 4½yds
- Binding fabric – ½yd
- Seventy-two (72) paper copies of FPP template (see Templates section)

Cutting out

1 From your assorted patterned fabrics cut as follows:

- Seventy-two (72) pieces using template A (squares).
- Thirty-six (36) pieces using template B (lemon).
- Seventy-two (72) pieces using template C (corner curve).

2 Cut the spike background fabric into 2½in x WOF strips.

3 Cut the white spikes fabric into 2½in x WOF strips.

4 From the inner border fabric cut six (6) 2½in x WOF strips.

5 From the outer border fabric cut seven (7) 3½in x WOF strips.

6 From the binding fabric cut seven (7) 2½in x WOF strips.

Making the blocks

7 Trim a 1½in piece from one of the spike background fabric strips and place on the back of one of the paper templates with the wrong side facing the back of the paper and ensuring that the fabric covers the whole of section 1 plus at least ¼in overlapping section 2 (**Fig 1**).

8 Pin one end of a white spikes fabric strip RST with the spike background piece so that when flipped over at the seam line, the white fabric will cover section 2 plus at least ¼in overlapping section 3. Flip the template so that the paper is uppermost and sew along the

BEHIND THE QUILT

PICKLE DISH DELIGHT

“The very talented designer Jennifer Paganelli will keep coming up with ever more sumptuous fabric collections and asking me to make quilts from them, and so the pressure is on! For her previous line I made a version of a New York Beauty quilt (issue 13), which worked surprisingly well with her large scale decorative prints, and so I scouted around for another design that would do something similar. The Pickle Dish pattern, with its curves and spikes has always attracted me, but as with the New York Beauty I had only ever attempted improv versions rather than the traditional block. This version has the least amount of spikes (or pickles) I could get away with as those FPP curves are quite time consuming. However, the rest of the block comes together surprisingly quickly and the stunning, kaleidoscopic quality of the overall quilt makes up for all that hard work.” – Jo Avery

Finished size

■ 70½in square

Notes

■ We used fabrics from Hotel Frederiksted by Jennifer Paganelli for Free Spirit Fabrics. Kona White was used for the “pickles”.

Master curved piecing in this pickle dish design

seam line between sections 1 and 2, extending into the marked seam line (Fig 2).

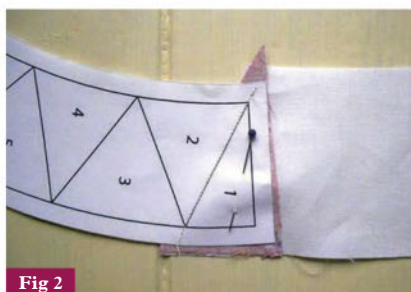
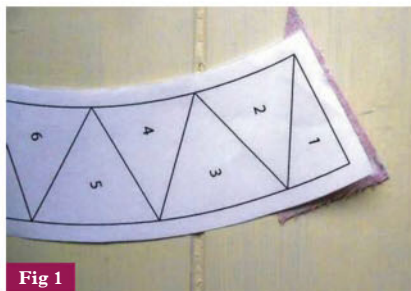

9 Fold and then press the white fabric over so it covers section 2. Fold the paper back at the seam line between sections 2 and 3 and trim the fabric to ¼in beyond the paper fold (Fig 3).

10 Repeat the process to cover section 3 with a red patterned fabric strip (Fig 4) and section 4 with white fabric. Continue alternating white and red patterned fabrics until all the sections are covered, with

white fabrics making the spikes on the inner curve and red patterned fabrics filling the background (Fig 5). Press.

11 Turn your completed spiky curve to the wrong side and trim away any excess fabric to size along the outer line of the paper template (Fig 6). Remove the papers by tearing carefully along the seam lines. Following steps 7-11 make a second spiky curve piece.



12 Take one of the lemon shaped (B) centres and fold in half to mark a centre point. Fold one of the spiky curves in half also. With RST pin the lemon to the spiky curve, matching centre points and edges and then filling the space in-between using plenty of pins (Fig 7). Sew together, carefully and slowly, easing your curved seam and pivoting every few stitches. Press (Fig 8).

13 Sew one of the squares (A) to each end of the second spiky curve (Fig 9). Following step 12, use the same technique to sew the second spiky curve to the other side of the lemon, matching points where the squares intersect. Press (Fig 10).

14 Using the same technique sew your corner curve (C) pieces to either side of the lemon to give a finished 10½in block (Fig 11).

15 Following steps 7-14 make another thirty-five (35) blocks using a mixture of different fabrics, but always keeping the red patterned fabric for the spiky curve background and the white fabric for the spikes.



TQ

TECHNICAL TIP

If you are struggling to sew smooth curves or get your pieces to fit, try starting your seam in the centre of the curve and stitch out to the edge, then rotate the block and finish the seam in the opposite direction.



16 Once all thirty-six (36) blocks are finished organise them correctly using the layout diagram shown in **Fig 12** below.

17 Sew the blocks together in six (6) rows of six (6). Sew these rows together to make your quilt top.

18 Sew the inner border strips together end to end to form one long length. Sew to one side of your top and trim, and then sew to the opposite side. Press. Sew the remainder of the strip to the top and bottom. Press. Repeat with the outer border strip.

Quilting and finishing

19 Piece the backing fabric by cutting the yardage into two equal lengths. Remove the selvages and sew together along the length with a $\frac{1}{2}$ in seam allowance, to form a centre seam. Press well all over.

20 Make a quilt sandwich of your backing fabric (right side down), the batting and the quilt top (right side up). Baste or pin the layers together and then quilt as you wish. The quilt shown was free-motion quilted using a flame pattern design.

21 Once quilted, trim off the excess backing fabric and batting and square up the quilt.

22 Prepare the binding by sewing the seven strips end to end to form one long length. Fold along the full length, wrong sides together and press. Use this to bind the quilt. 🧑🏻‍🔧



Pops of pink, green, blue and red really make this design stand out

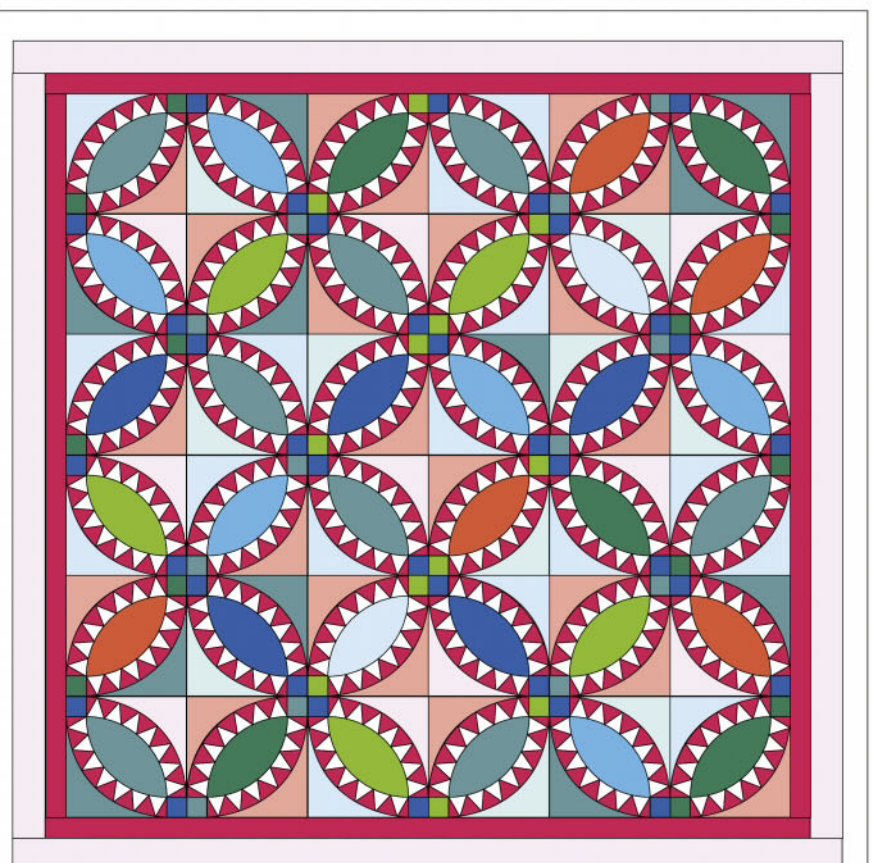

Fig 12 Layout diagram



Meet the designer

Jo Avery has been quilting for the last 25 years and writing her craft blog for seven years. She runs her own fabric and craft supplies shop, myBearpaw, in Edinburgh and online, as well as teaching there and around the UK and Europe. She also organises the Stitch Gathering, an annual Modern Quilt Retreat, and is part of The Thread House, offering quilting retreats and selling patterns, www.thethreadhouse.co.uk.

www.mybearpaw.com [@mybearpaw on Instagram](https://www.instagram.com/mybearpaw)

With the gorgeous fabrics shown off to perfection, this quilt is sure to be a winner with friends and family

TODAY'S QUILTER

Create beautiful quilts for your home

GET THE DIGITAL EDITION OF YOUR FAVE MAG!



Perfect for your iPad or iPhone!



Have *Today's Quilter* delivered straight to your device and enjoy while at home or when you're out & about

Simply search for *Today's Quilter*, download the app and get quilting!



* iPad is a trademark of Apple Inc., registered in the U.S. and other countries. App Store is a service mark of Apple Inc.



FROM THE DESK — of — Lynne Edwards MBE

Help needed...



up along the way on these trips.

When I get back, there are bills to pay, letters to answer, domestic issues to sort, although nothing like as much as there used to be before email became part of so many people's lives. And there, nestling in the "to do" section of my electronic correspondence is a pile of questions from readers of *Today's Quilter*.

So now I am at my desk and ready to tackle some of them. I'm not comfortable

having lots of letters that are waiting for an answer, and some of these questions need a whole article or part of a book to deal with, so I thought I'd make an inroad into the ones that I can answer in a relatively short space. What you need to remember is that all my thoughts on your problems are simply my own approach and my own strategies, which are not necessarily the only way to go. Please don't react with outrage if what I suggest is absolutely not what you believe is the right way to do stuff. If your way works for you, just carry on doing it! And I will do the same.

Nestling in the "to do" section of my electronic correspondence is a pile of questions from readers of *Today's Quilter*.

So, it seems a good idea to deal with a few letters about getting started in the craft. That way the more experienced among you can give it a quick glance just to check that I'm getting it right and then move on to something else in the magazine... No bad thing to be reminded, though, how lacking in confidence and basic knowledge the beginner quilter may be.

Lynne



**YOU'VE
GOT
MAIL**



Ask Lynne your questions

When planning a quilt how do you calculate how much material you need?

– Janet

Always far more than you think possible, Janet! About eight to nine metres in total for the top of a double bed quilt and six metres for a single bed. A lap quilt or baby quilt can vary in size greatly, so think of the final measurements of what you want to make and then compare this with a single bed quilt and make a rough estimate of their comparative sizes to find out how much fabric you need. You will, of course, always run out of at least one of the main fabrics, and that is why patchwork is such a great craft to be doing, as the creativity and inventiveness is always being stretched when you have to introduce and blend in new fabric for the design as you go along.

I am a beginner quilter and have been taking advantage of the sales and buying a lot of fabrics.

The problem is I have all sorts of patterned fabrics of various colours, but do not know how to combine them to make a pleasing block. How do you combine these fabrics?

– Sophia

I fear you have succumbed to the devilish bug called fabric-lust, Sophia, and are now an addict. Welcome in – you are among understanding friends. You have started to build up your core collection of fabrics that you long to use, but of course, they are all stars, and you also need a few low-key fabrics as a support to help these little beauties to combine in a design – textured fabrics or solid colours are probably best. Start by



Who can resist a pile of colourfully-patterned fabrics? You just need to find projects to use them all in!

taking out two or three pieces from your collection that you feel look good together. You might even have two separate groups, just in case the first ones don't work out. Spend some time in an understanding quilt shop auditioning your group of fabrics with some suitable candidates for the calming elements in the planned design. Open out the one you think might make the background and arrange the others folded roughly into the design you will be making. Switch them round, trying another as the background. You might find you need two of these quieter fabrics – keep trying them until you are happy.

And a final thought: just because you have bought a piece of fabric, you are not obliged to use it if finally the arrangement doesn't seem to work. Fabric can be as wilful as children... and possibly as expensive. If it doesn't look good as the design progresses, set it aside for another time and another project.

Is it a good idea to use fabrics from old clothes curtains etc?

– Anne

Do you recommend starching your fabric before cutting?

– Elise

Aha! Here is one of those areas, which really gets quilters arguing, as opinions differ. Some will suck their teeth and dictate real rules to keep the craft pure, while I prefer to encourage a more open-minded approach (in other words, ignore any Quilt Police and do what you like). So, for me I would encourage using old fabrics – washed and worn, I can identify with that...

Just a few guidelines. Some fabric is going to be far thicker than the usual cotton that's used for patchwork, and you might find that hard to physically get a good result for your design. The wonderful Mary Fogg

believed in mixing all sorts of different fabrics in her pieces, as a celebration of how they worked together visually, but she kept the designs of her quilts very simple, mainly strips and large squares or rectangles. Part of this was so that the fabrics were the headliners, not the intricacy of the pattern, but also because tweeds and velvets are not always easy to make really sharp points and can create bulky seams. Old clothes are always a favourite to incorporate, especially if they carry fond memories of people and places from the past. Be aware, though, that they may have been very much used, and now be close to wearing out. Avoid parts of shirts that are really worn, and pick the large relatively strong sections like parts of the sleeves or the tails.

While you're at it, think out of the box and use the pockets in your design too – why not? I saw a great cushion where the maker had used the front of the shirt with all its buttons and buttonholes as the back of the cushion, so that way no zip was needed. I have a much loved tablecloth that was my first major patchwork project made many years ago, mostly with old favourite fabrics, and I can no longer use it because the faded curtains from my granny's kitchen were so near the end of their life that now they are at the point of disintegrating. So, don't ban stuff from your quilts, but be realistic about any limitations they may have and cut your cloth accordingly – ho ho.

As for starch, I use it when I am working with a soft or floppy fabric to keep it in order while cutting and stitching. Just check that the spray doesn't leave a watermark on the fabric. You have to make the decision on whether to starch or not before you start cutting it up, I'm afraid, as the process of spraying and then ironing it dry will distort a cut shape so that then it isn't the same exact measurement that you need.

I'm a novice quilter and would like to know if it's best to stick to all 100% cotton fabric or can you mix in some polycotton?
– Jess Smith

I think I've just shot myself in the foot, Jess, because I have just said try anything if you like it, and now with this question I'm not so sure. I can only speak from my own experience, which is that generally polycottons seem to have an innate springiness, which makes getting them to lie flat and hold hands with surrounding shapes in a design hard to achieve. I have had several students who wanted to use old shirts for their quilt, and have determinedly included polycotton shirts and somehow made it work. Synthetic fabrics do need a cooler iron than natural fabrics, of course, and have been seen to shrink and slightly pucker at the ironing board when a pieced section is being pressed. So I would say don't specifically buy a length

of polycotton for a project, but if you are using recycled stuff, just test the fabric for good behaviour before using it by joining a small piece to one of your other chosen fabrics and then pressing it. Incidentally, I bought a selection of Paul Smith shirting fabrics from a stand at a quilt show which, while labelled as pure cotton, proved really bouncy and hard to use – I suspect they had been treated with a non-crease finish to make them easy to iron as a shirt. If the label hadn't specifically said they were cotton, I would have set them aside with a roll of the eyes, but because they were of such a high-class lineage, I persevered and used them. We battled, but I won, because I was determined to, and took no prisoners. My choice, and they do look good now. Like childbirth, you forget the pain afterwards...



Send us your questions for Lynne on social media or pop them in an email. Alternatively, put pen to paper and write to:
The Desk of Lynne Edwards MBE
c/o Today's Quilter
Immediate Media, Tower House,
Fairfax Street, Bristol, BS1 3BN



HOCHANDA

HOME OF CRAFTS HOBBIES AND ARTS

HOME OF YOUR FAVOURITE BRANDS

FREEVIEW 85 (24/7)

FREESAT 817 (24/7)

SKY 663 (24/7)

Debbie
HORE



Leonie
Pujol



Power
tex



all

SPECTRUM NOIR™

THE UK's
INSPIRATIONAL
CRAFT TV CHANNEL



Claritys



Crafter's
Companion

Stamps
by Chloe

Die'sire
BY CRAFTER'S COMPANION



TUNE IN TODAY...
OR WATCH ONLINE AT
WWW.HOCHANDA.COM



FAVOURITE
BRANDS



FRAME PROJECT

RED & WHITE MEDALLION

*Bring a country cottage feel to any
room with this charming design.*

Designed and made by **MANDY SHAW**

www.dandeliondesigns.co.uk

FRAME PROJECT

RED & WHITE MEDALLION



You will need

- Six (6) fat quarters in similar shades
- Red border fabric – 3in x WOF
- Appliqué and binding fabric – ½yd
- Mix of light background fabrics – 2½yds
- Fusible web
- Foundation piecing and appliqué templates (see Templates section)
- Batting – 56in square
- Backing – 56in square
- Cotton a broder (optional)
- Freezer paper (optional)

Cutting out

1 From the background fabrics cut as follows:

- One (1) 16½in square (centre panel).
- Two (2) 2½in x 18½in (border 2).
- Two (2) 2½in x 22½in (border 2).
- Eighty-eight (88) 2½in squares (border 3, Flying Geese).
- Four (4) 4½in squares (border 3).
- Two (2) 2½in x 30½in strips (border 4).
- Two (2) 2½in x 34½in strips (border 4).
- Ten (10) 2½in x 21in strips. (border 5).
- Four (4) 2½in squares (border 5).
- Six (6) 2½in x WOF strips pieced into one length and sub-cut as follows:
 - Two (2) 2½in x 46½in strips (border 6).
 - Two (2) 2½in x 50½in strips (border 6).
- Nine (9) appliqué flower centres (see Templates section).

2 From the print fat quarters cut as follows:

- Six (6) pentagons using the template (see Templates section) (centre panel).
- Forty-four (44) 2½in x 4½in rectangles (border 3, Flying Geese).
- Eleven (11) 2½in x 21in strips (border 5).
- Four (4) 2½in squares (border 5).
- Eight (8) 2½in x 4½in rectangles (border 5).
- Four (4) 2½in x 6½in rectangles (border 5).

BEHIND THE QUILT

LEARN SOMETHING NEW

“This is a very pretty and relatively easy quilt. It includes some great techniques for you to learn, including English paper piecing, appliqué, folded Flying Geese, nine-patch, off-centre Log Cabin and Square-within-a-Square foundation piecing, as well as machine and hand quilting, and rotary cutting skills.” – Mandy Shaw

Finished size

- Approx. 50in square

Notes

- Make sure all the seams are $\frac{1}{4}$ in throughout, this is very important so that everything fits together well. If the centre square is not the correct size once appliquéd nothing else will fit.
- Wash any strong colours to remove excess dye. Lightly spray starch and iron the fabric.

3 From the red border print cut as follows:

- Two (2) $1\frac{1}{2}$ in x $16\frac{1}{2}$ in strips (border 1).
- Two (2) $1\frac{1}{2}$ in x $18\frac{1}{2}$ in strips (border 1).

4 From the appliqué and binding fabric cut as follows:

- Five (5) $2\frac{1}{2}$ in x WOF strips.
- Nine (9) appliqué flowers (see Templates section).

Making the centre panel

5 Using the pentagon template (see Templates section), trace six (6) pentagons onto the non-shiny side of your freezer paper. Make sure you use a propelling pencil and are very accurate. If you do not have any freezer paper, ordinary paper will do. Cut out the pentagons along the line.

6 Pin each individual pentagon to the wrong side of six (6) different fabrics, lining up the straight of the grain. Cut out roughly with a $\frac{1}{2}$ in seam all the way around. Iron the freezer paper template in place.

7 Fold the seam allowance over the freezer paper and tack in place. There will be excess fabric at the tip of the pentagon that will fold to one side, this is normal.

8 Lay out the pentagons into a circle so the colours are balanced. Place two pentagons right sides together. Cast on with a small knot and three stitches on top of each other and whipstitch the short edges together with very small stitches.



TQ

TECHNICAL TIP

Use $\frac{1}{4}$ in masking or Quilter's tape to create accurate $\frac{1}{4}$ in seams. Stick it to the raw edge of your seam and sew very close to the tape edge. It can be used more than once.

Open out and sew another pentagon on. Be careful to sew the short side seams only. Make two (2) halves and then sew the halves together (**Fig 1**). Once the star is complete, press.

Fig 1

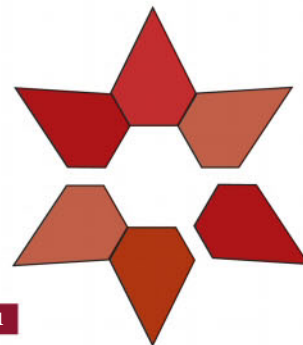

9 Take the $16\frac{1}{2}$ in square of background fabric. Press and lightly spray starch. Fold in half in each direction and lightly press to mark the centre. Open out the fabric.

10 Pin the pentagon star in the centre of the background fabric, using your pressed lines as a guide. Sew the star in place all the way around using an appliqué stitch (**Fig 2**). Undo any tacking. Press. Add an appliqué flower to the centre.

Fig 2

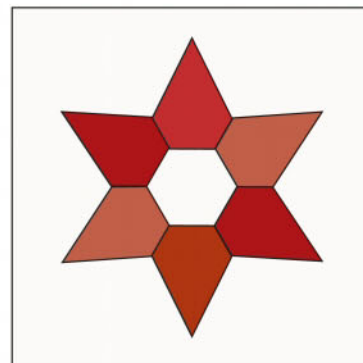



TECHNICAL TIP

To baste your fabric pieces to your paper templates you can buy a special tacking thread, which is an inexpensive thread that breaks easily. Otherwise, use old threads in colours that you no longer use. The thread will be unpicked at the end so it does not matter what colour you choose.

11 Make a small slit in the background fabric under the shapes and gently remove all the papers. The slits will never be seen so does not need to be sewn up.

Adding borders 1 & 2

12 Take the two (2) 1½in x 16½in and two (2) 1½in x 18½in of red border fabric. Sew the two shorter strips to the top and bottom of the block. Pin each end of the strip to the block first and then ease the rest of the strip between both pins. Press and then repeat with the sides.

13 Add the two (2) 2½in x 18½in and two (2) 2½in x 22½in background strips in the same sequence; the shorter ones to the top and bottom and the longer ones to the side.

Making border 3 – folded Flying Geese

14 Take the forty-four (44) 2½in x 4½in rectangles in a mixture of print fabrics and eighty-eight (88) 2½in background squares. Fold one red rectangle in half, wrong sides together.

15 Put the folded rectangle onto the right side of one of the background squares, with the fold facing up and matching all raw edges in one bottom corner. Place on top, right sides together, the other square (Fig 3A). Sew with a ¼in seam down one side, through all layers (Fig 3B).

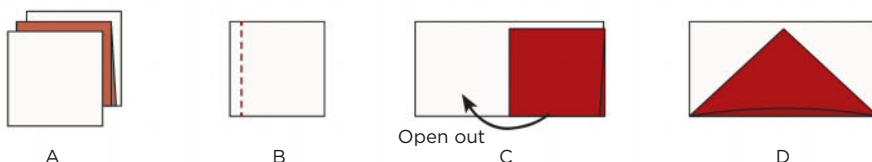

Fig 3

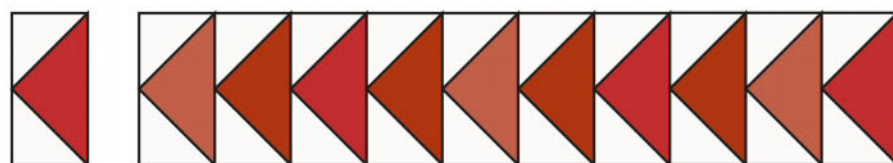

Fig 4

16 Open out the folded fabric into a triangle and press (Fig 3C and 3D). Press the seam open on the reverse, flattening the little triangle at the top of the seam. The tip of this triangle will be your sewing guide when you join the Flying Geese together. Repeat to make forty-four (44) Flying Geese.

17 Sew the geese together in four (4) rows of eleven (11)

being very accurate with your seam allowances, you can nip and tuck a little along the way, but each row should measure 22½in (Fig 4).

18 The next block will be the four cornerstones. Take the four (4) 4½in squares of background fabric and appliqué a flower onto the middle of each square using fusible web. Stitch the flower in place with blanket stitch.



19 Join two (2) of the Flying Geese strips to the top and bottom of the quilt centre. Pin each end of the strip to the centre block first and then ease in the rest of the strip. Sew with an accurate $\frac{1}{4}$ in seam allowance. Press.

20 Sew the appliqué squares to each end of the remaining two strips and sew these strips to the sides of the medallion centre (Fig 5). Press.

Adding border 4

21 Take the two (2) $2\frac{1}{2}$ in x $30\frac{1}{2}$ in and two (2) $2\frac{1}{2}$ in x $34\frac{1}{2}$ in strips of background fabric. Sew the shorter ones to the top and bottom and the longer ones to the sides. Press.

Making border 5 – Square-in-a-Square

22 Photocopy the foundation piecing template five (5) times onto cheap paper (this is easier to sew through than expensive heavier weights). Cut out four (4) paper



Fig 5

foundation patterns roughly $\frac{1}{4}$ in from the marked outside line.

23 Using another paper foundation pattern, cut out all the shapes on the inside lines. These will be used as cutting out templates from the fabric for each pattern piece.

24 Take pattern piece number 1, place it onto the wrong side of a piece of the background fabric, making sure the right side of the pattern piece is facing you. Pin in place and cut out with a generous $\frac{1}{2}$ in seam, this is very important.

25 Pin this piece of fabric onto the wrong side of the paper foundation pattern, making sure you cover the whole shape numbered 1 and at least $\frac{1}{4}$ in all around. You may not be able to see the shape through the fabric so you may have to hold it up to the light. Pin in place.

26 Take pattern piece number 2, a print piece, and place it onto the wrong side of a piece of fabric making sure the right side of the pattern piece is facing you. Pin in place and cut out with a generous $\frac{1}{2}$ in seam.

27 Place this piece of fabric, right sides together onto the previous fabric, so that it will cover shape 2 plus at least $\frac{1}{4}$ in when flipped over. Pin along the line



between one and two, flip it back to check the fabric covers the shape. If all is well, turn the fabric and pattern over to the right side of the paper and sew on the line between 1 and 2. Backstitch at the ends to secure the stitches.

28 Flip back to check all is still well, all the pattern including the outside seam allowances must now be covered. Trim seam allowance to a rough $\frac{1}{4}$ in and press.

29 Repeat with the other pattern pieces in numerical order. Once the block is sewn, press and trim to the correct size (the outside line of the seam allowance), see **Fig 6**. Make four (4) of these blocks. Do not remove paper until the blocks are sewn into the borders, this will protect any bias edges and help keep the blocks nice and square.

Making border 5 – nine-patch blocks

30 The nine-patches are made with $2\frac{1}{2}$ in x 21in strips from your print and background fabrics. Join them in rows as in **Fig 7**, sewing

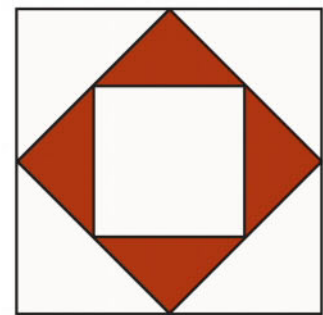

Make 4

Fig 6

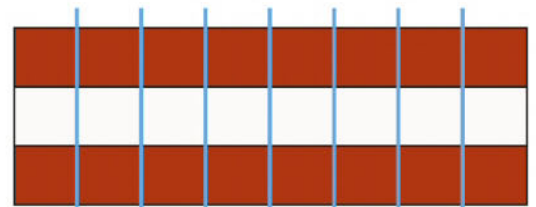

Make 4

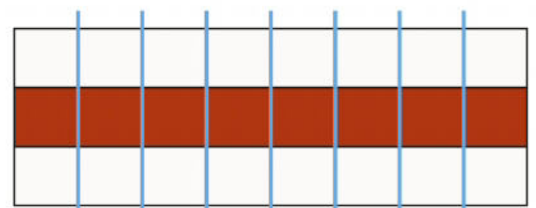

Make 3

Fig 7

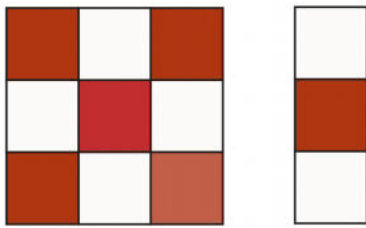

Make 16

Make 8

Fig 8

the seam allowance very accurately. Make three (3) rows with two (2) background strips and one (1) print strip, and four (4) with two (2) print strips and one (1) background strip. Press the seams towards the print strips in each row.

31 Cross-cut the strip units into fifty-six (56) $2\frac{1}{2}$ in units. Cut thirty-two (32) from the mostly print units and twenty-four (24) from the mostly background units. Stitch the units into sixteen (16) nine-patches, leaving eight (8) fillers (Fig 8). Sew two blocks and one filler together to form the row, make eight (8) of these.

Making border 5 – Log-Cabin blocks

32 Make four (4) off-centre Log-Cabin blocks. Stitch one $2\frac{1}{2}$ in print square to a $2\frac{1}{2}$ in background square. Press seams towards the print square. Join a $2\frac{1}{2}$ in x $4\frac{1}{2}$ in print rectangle to one side, press. Repeat to add another $2\frac{1}{2}$ in x $4\frac{1}{2}$ in print rectangle and finally a $2\frac{1}{2}$ in x $6\frac{1}{2}$ in print rectangle to finish the block (Fig 9). Make two (2) facing one direction and two (2) in reverse (Fig 10).

33 Sew your nine-patch rows to either side of the Square-within-a-Square to make four (4) borders (Fig 11). Sew two of these borders to the top and bottom of your quilt. Press.

34 Add the Log-Cabin blocks to each end of the remaining borders and sew them to each side of the quilt matching your seams well at the corners (Fig 12). Add appliqué flowers to the corner Log-Cabin blocks.

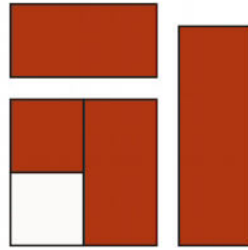
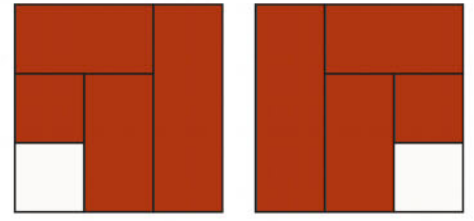

Fig 9



Make 2

Make 2

Fig 10

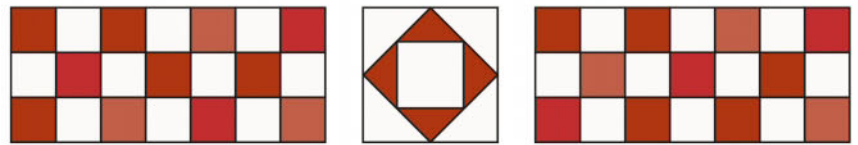

Fig 11

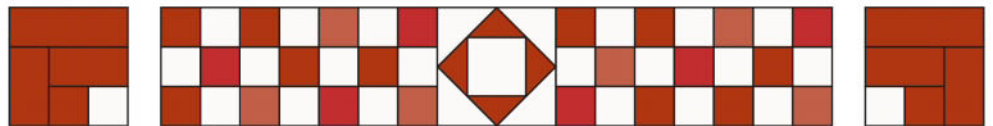

Fig 12





TQ

TECHNICAL TIP

On smaller projects, I sometimes use a can of spray adhesive for basting. You will have to follow the manufacturer's instructions, but it does make life very easy indeed. The quilt must be washed to remove the adhesive once finished!

Adding border 6

35 Take the two (2) 2½in x 46½in and two (2) 2½in x 50½in strips of background fabric. Sew the shorter ones to the top and the bottom, press, then sew the two longer ones to either side, press (Fig 13).

Quilting and finishing

36 Prepare the quilt for layering by pressing all the seams and cutting off any stray threads. Cut a piece of backing fabric and a piece of cotton batting at least 2in bigger all around the quilt top.

37 Lay the backing fabric on a flat surface, wrong side facing you and smooth it out. Secure flat with some sticky tape or masking tape. Lay on top the batting, smooth it out flat. Place the quilt on top, smooth it out and pin with safety pins every three inches.

38 Quilt as desired, bind and add a label to finish. 🧵

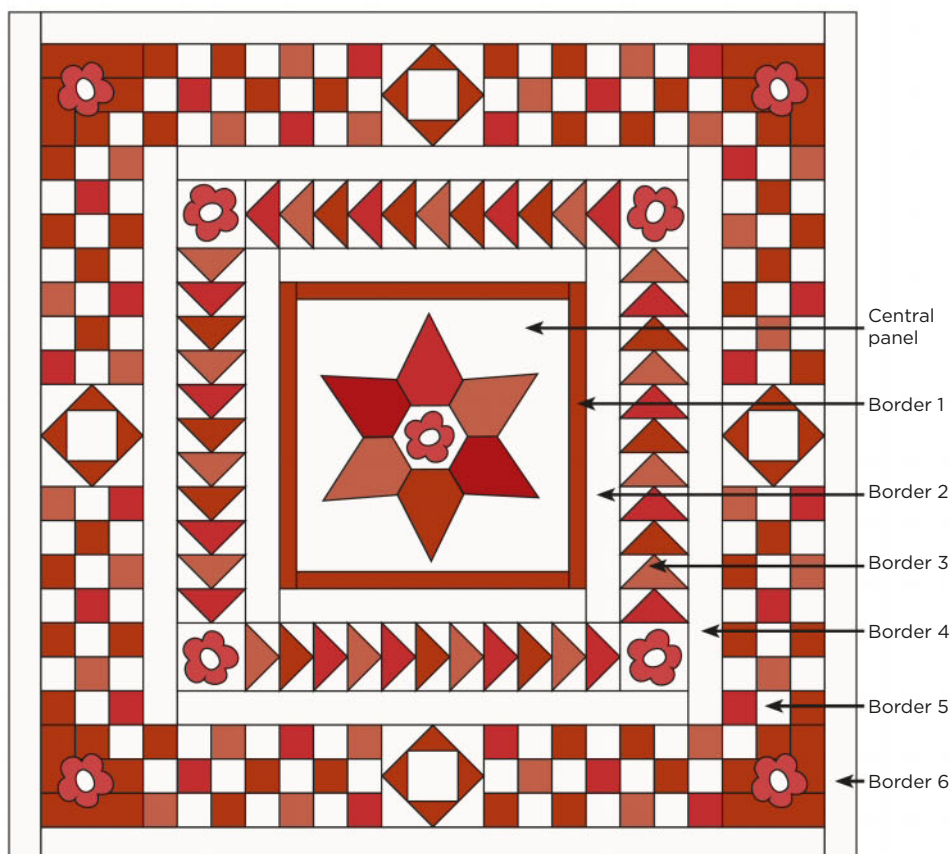

Fig 13



Meet the designer

Mandy Shaw is the owner of Dandelion Designs, an online shop full of craft patterns and hard-to-find haberdashery items like prairie cloths, cotton tapes, 100% wool felt and other items that she likes to use in her patterns. She has appeared in numerous magazines and on *Kirstie's Homemade Christmas*, and *Kirstie and Phil's Perfect Christmas*. She lives in East Sussex with her husband and four children.

www.dandeliondesigns.co.uk

This delightful quilt with appliqué flowers and checks is sure to keep you nice and cosy



Poppy Patchwork

Looking for fabric? Then look no further ...

Visit my shop in Bristol

71 Westbury Hill, Westbury on Trym, Bristol, BS9 3AD

Shop Online

www.poppypatchwork.co.uk

Shop by phone

0117 962 2656
or 07900 927279

New Shop Hours Mon - Sat, 9.30 - 4.00pm, Closed Wed

The Patchwork Basket

Tel: 01531 822442

8 Church Street, Newent, Nr Gloucester GL18 1PP

Fabrics, Waddings and Notions
Workshop Schedule available online
For all your general sewing needs!



Opening Times:
Tuesday - Friday 10.30am - 5.00pm
Saturday 9.30am - 5.00pm
10 minutes from J3 of the M50

Maching Sales
& Repairs
JANOME
...Dressmaker's Choice

www.thepatchworkbasket.co.uk

Calico Kate

36 High Street, Lampeter SA48 7BB

01570 422866

Award-winning fabric shop:
twelve rooms to explore!



www.calicokate.co.uk

Fabric, Notions &
Long-Arm Quilting Ser-
vice

QUILTERS
Trading Post

Buerton Old School,
Woore Road, Buerton,
Cheshire, CW3 0DD
Tel: 01270 812541



**Pam's Flower
Garden**
Applique
Patterns & Projects

NEW and available
instore or online at

www.quilterstradingpost.com

Patchfinders

Now at

159 London Road South, Poynton, Cheshire

SK12 1LQ

01625 262518

Bigger, Better, Even More Choice!!

Courses running all year

www.patchfinders.com

10% off
Use code
TQ16

The
PlainStitch
Workroom

Modern Patchwork and Quilting Shop
and Sewing School

Stocking Lewis & Irene, Cotton & Steel, Art Gallery Fabrics,
Riley Blake, Dashwood Studios, Tilda Fabrics, Dear Stella,
Windham Fabrics, Sevenberry, Freespirit, Aurifil Threads

First Floor, 8 High St, Wendover,
Buckinghamshire, HP22 6EA

See website for shop opening hours

01296 622243 www.plainstitch.co.uk @plainstitchdeb



Amish Patchwork Tours

by Janet Wallace



If you love the art of Patchwork & Quilting and would like the holiday of a lifetime filled with fun, fabric and friends then join me, the **NUMBER 1 QUILT TOUR SPECIALIST TO THE USA**. Come with me as I travel around the USA whether it be Lancaster, Paducah, New England, Indiana, Houston or anywhere else we land, my unique itineraries are jam-packed with exciting events, private lectures, behind-the-scenes tours, shop-hops, and quilt shows that are sure to delight every level of quilter.

Join me and become part of the traveling sisterhood of quilters that have trusted their holiday dreams to UK's Favourite Quilt Tour Company, Amish Patchwork Tours.

Why trust your memories to anyone else? Let me make your quilt tour dreams come true...but don't wait too long - these dreams go quick!!!

NOW TAKING BOOKINGS FOR 2017

You will not be disappointed when you join one of my tours

www.amishpatchworktours.com janet@amishpatchworktours.com 01332 905601

TODAY'S QUILTER

Create beautiful quilts for your home

For advertising opportunities call
Tiffany Jackson on 0117 300 8203 or email
tiffany.jackson@immediate.co.uk

60-DEGREE TRIANGLES

FIRECRACKER

*The New Year starts off with a bang,
so why not follow suit with
this firecracker design that's
a blast to make.*

Designed and made by **PAM & NICKY LINTOTT**

Quilted by **THE QUILT ROOM**

www.quiltroom.co.uk



60-DEGREE TRIANGLES
FIRECRACKER



BEHIND THE PROJECT

FIRECRACKER

“We used a collection of Amish solids to create this stunning quilt. You do accumulate a number of offcuts when creating it, however, and we were determined not to waste them. Our quilt back is gorgeous and we love it nearly as much as the quilt top. It really was the perfect solution and nothing was wasted.” – Pam Lintott

You will need

Quilt top:

- One (1) Jelly Roll OR forty (40) 2½in x WOF strips
- Border fabric – 1yd
- Binding fabric – ½yd
- Creative Grids 45/60 or any 60-degree triangle ruler

Sorting your strips

1 Choose thirty-six (36) Jelly Roll strips and sort them into eighteen (18) pairs. Four (4) strips are spare.

Cutting out

2 From the border fabric cut as follows:

- Four (4) 6½in strips across the width of the fabric. Set aside for the borders.
- Two (2) 3½in strips across the width of the fabric. Lay the 60-degree triangle ruler on a strip, lining up the 3½in marking along the bottom of the strip and the nubbed off top of the triangle at the top of the strip (**Fig 1**). Cut one triangle. Rotate the ruler along the strip to cut ten (10) triangles (**Fig 2**). Repeat with the second strip to make a total of twenty (20). Set these aside for the top and bottom triangles of each vertical row.

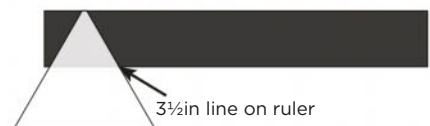

Fig 1

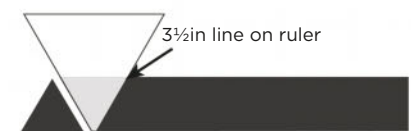

Fig 2

3 From the binding fabric cut six (6) 2½in strips across the width of the fabric.

Making the star blocks

4 Take one pair of Jelly Roll strips and sew them together to form a strip unit as shown in **Fig 3**. The top fabric will form the background of the block and the bottom fabric will

Pieced quilt back:

- Backing fabric – 3yds
- Cut off triangles from quilt front
- Batting – 50in x 60in

Finished size

- Approx. 43in x 52in

become the star. Press the seams to the darker fabric.

5 Cut the strip unit into twelve (12) $3\frac{1}{2}$ in segments to make twelve (12) rectangles $3\frac{1}{2}$ in x $4\frac{1}{2}$ in (**Fig 4**).

6 Working with one rectangle at a time, rotate each rectangle 90 degrees to the right so the background fabric is always on the *right* (**Fig 5**).

7 Place the 60-degree triangle on the rectangle aligning the $3\frac{1}{2}$ in line along the bottom of the rectangle and the nubbed off top of the triangle with the top of the strip unit (**Fig 6**). Cut the triangle and repeat with all twelve (12) rectangles from the strip unit.

8 The cut off fabric is spare but keep this to one side for your pieced quilt back.

9 Take three (3) triangles and sew them together as shown in **Fig 7** to make a half hexagon. Press as shown before sewing the next unit in place. Repeat with all twelve (12) triangles to make four (4) half hexagons. **Note:** Do not sew the half hexagons together to form hexagons at this stage.

10 Make four (4) half hexagons from each of the eighteen (18) strip units to make a total of seventy-two (72) half hexagons (**Fig 8**). You need seventy (70) so two (2) are spare.

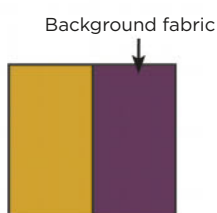

Fig 5

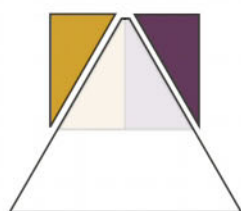

Fig 6



Fig 7



Fig 8

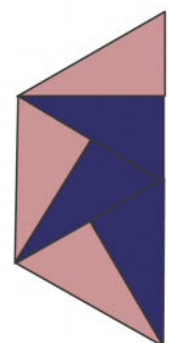

Make 70



Fig 3



Fig 4



Fig 9



Fig 10

Assembling the quilt

11 Referring to **Fig 9**, lay the half hexagons into ten (10) vertical rows of seven (7) as shown, making sure you match the half hexagons carefully so they form full hexagons. Add a background triangle to the top and bottom of each vertical row.

12 When you are sure they are in the right place, sew the half hexagons into vertical rows and then sew the vertical rows together, pinning at every seam intersection to ensure a perfect match. Press the seams of alternate rows in opposite directions to help when sewing the seams, there will be occasions when you might have to re-press a seam to do this.



Fig 11



Adding the borders

13 Determine the vertical measurement from top to bottom through the centre of your quilt top, measuring from the tip of the hexagon in the top row to the tip of the hexagon in the bottom row. Trim two side borders to this measurement. Pin and sew to the quilt (**Fig 10**). Press.

14 Determine the horizontal measurement from side to side across the centre of the quilt top. Trim two borders to this measurement. Pin one to the top of the quilt aligning the sewing line with the top of the hexagons to form a straight edge (**Fig 11**). Sew and cut off the excess fabric.

Press. Repeat with the border at the bottom of the quilt (**Fig 12**). Sewing the borders in this order means you do not have any seams in the borders.



Fig 12



Making the pieced back

15 From the backing fabric cut as follows:

- Five (5) 6½in strips and set aside for the borders of the quilt back.
- Fourteen (14) 4½in wide strips across the width of the fabric. Subcut each strip into six (6) 4½in x 6½in rectangles. You need eighty (80) in total so four (4) are spare.

16 You need to make a template so you can trim the corners of the rectangles to the correct size. To do this, take one of the cut off triangles from step 8 and trim ½in from the long angled side (**Fig 13**). Discard the ½in strip and the smaller triangle will be your template.

17 Lay the template on one corner and cut away the corner of the rectangle. Repeat on the diagonal corner (**Fig 14**). We strongly recommend sewing one block to make sure you are not cutting away too much because if you cut away too much your cut off triangles will be too small.

18 Choose two cut off triangles and with right sides together

sew to the corners (**Fig 15**). Press and, using a quilting ruler, trim to size.

19 Repeat with all eighty (80) rectangles. Sew eight (8) together to form one vertical row. Repeat to make ten (10) vertical rows. Press seams of alternate rows in opposite directions and sew the rows together pinning at every seam intersection to ensure a perfect match.

20 Complete the quilt back by sewing the outer border strips into a continuous length (**Fig 16**), and sewing to the quilt back in the same way as the quilt front.

21 Your quilt top and back are now complete and ready for quilting. We wanted a bold, modern quilting design which would work well on both the front and back of the quilt. We chose a simple figure-of-eight pattern in a grey thread. The thread really shows in the black borders but does not affect the overall pattern. It also “melts” into the quilt back and gives our modern quilt a really good texture and depth.

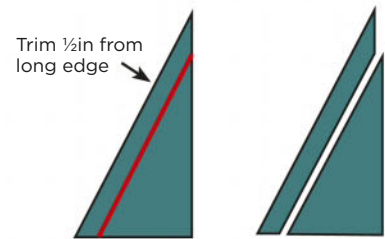

Fig 13

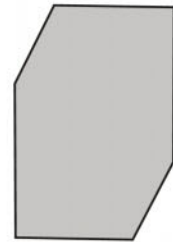

Fig 14

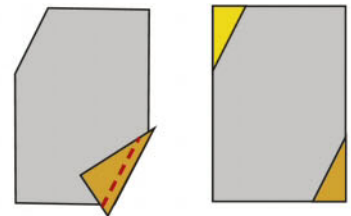

Fig 15

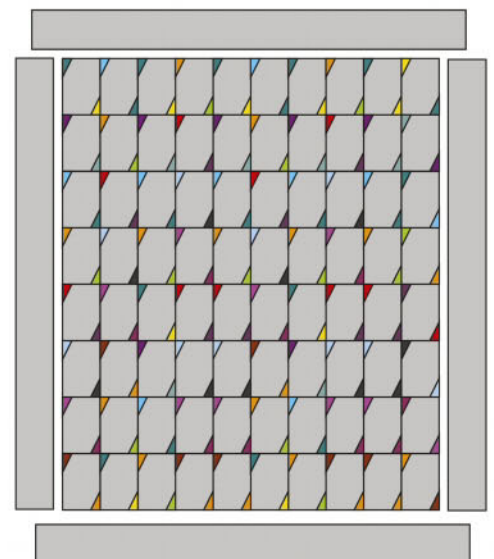

Fig 16

22 After quilting, trim to size. Sew the six binding strips into a continuous length and bind to finish. Add a label with your name, date and any info about the fabrics used. 🧵



Meet the designers

Pam and Nicky Lintott own The Quilt Room based in Dorking, Surrey, where they have a shop in a 15th-century inn, plus a studio where they operate an efficient mail order business plus a long-arm quilting service using their two Gammill Statler Stitches. They have written 11 books on Jelly Roll quilts and other pre-cuts published by David & Charles.

www.thequiltroom.co.uk [thequiltroom](https://www.facebook.com/thequiltroom) [@thequiltroom](https://www.instagram.com/thequiltroom)

Light up any room with a burst of firecrackers with this colourful quilt

Latest Heavenly Designs

from Helen Butcher



CUBITZ STARLIGHT
quilt kit £49

MOONLIT SEA
wallhanging kit £41

MOONLIGHT SERENADE
3 cushion kit £35

Oakshottfabrics

www.oakshottfabrics.com

Tel: +44 (0)1452 371571



Alice Caroline
ENGLAND

LIBERTY fabric specialist with over 450 Liberty classic and new season prints in stock. Yardage, fat quarters, bundles, scraps and patterns available.
Gorgeous new florals and Spring/Summer 2017 prints
www.alicecaroline.co.uk

The Bramble Patch

Britain's premier destination for patchwork, quilting & fabric arts



the quilter's quilt shop...

fabric • wadding • haberdashery • tools • kits • books • classes & workshops • long-arm quilting service • exhibitions & events • Conservatory Coffee Shop • "Box of Delights" monthly quilters' subscription box

www.bramblepatchonline.com

West Street, Weedon, Northamptonshire, NN7 4QU • 01327 342212



SEW HOT
sew you, sew now

The Hottest New Trends In Sewing & Quilting



Patterns Fabric Notions

10% off your first order with code TQ10

SewHot.co.uk

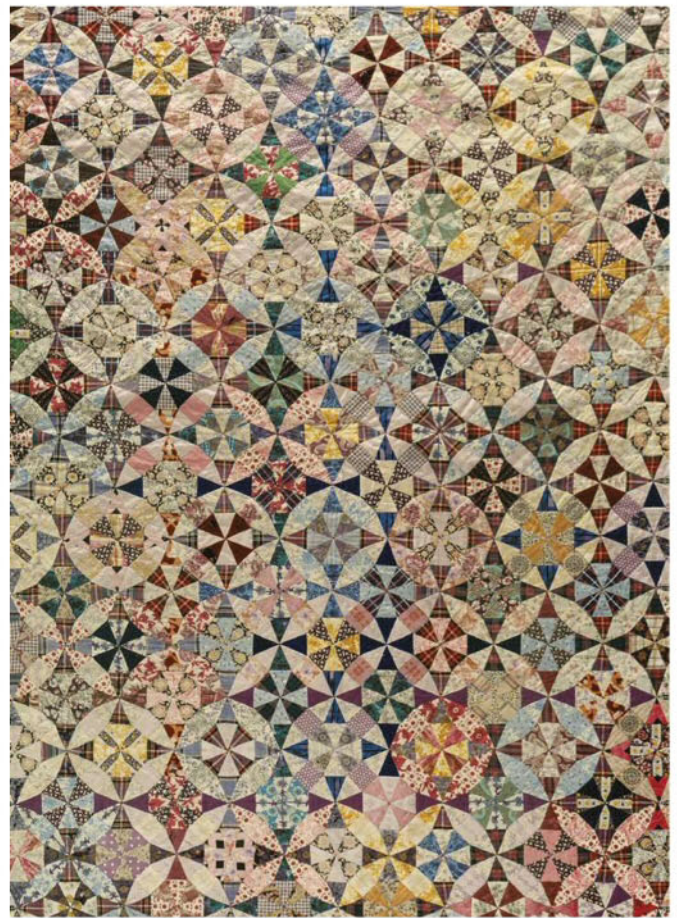

Left, Passacaglia patchwork; Above, Kaleidoscope patchwork; Right, The Patchwork of the Crosses in situ at The Manor, Hemingford Grey



Rediscovering the PATCHWORKS OF LUCY BOSTON

Jane Rae explores the magical world of Lucy Boston where literature, patchworks and horticulture converge.



Below, Built in the 1130s The Manor is one of the oldest continuously inhabited houses in Britain; **Bottom,** Lucy Boston, in her eighties, when she was most active with her patchworks



Lucy Boston was born in 1892 in Southport in Lancashire. She enjoyed great success as the author of the *Green Knowe* series for children and in her lifetime wrote 19 books (all after the age of 60). At the age of 47 she embarked upon the restoration of a 12th century manor house in Cambridgeshire and together with her writing and her needlework, this became her life's work. In her external world she created a sensory garden filled with 200 old roses, herbaceous borders and artistic topiary, and in her internal world, she created a collection of beautiful patchworks. With every year that came and went at The Manor, she more than fulfilled her creative expectations, with summers spent in the garden and winters in her armchair by the dining-room fire with her beloved patchwork. In a letter to her niece, Caroline Hemming, she wrote:

"The patchwork is finished and edged but not yet lined. I am waiting for the lining and meanwhile can't imagine how I lived when I wasn't patching. It is flatter than finishing a book."

These letters, anecdotes from family and friends, and remembrances were lovingly collected and pieced together by Lucy's daughter-in-law, Diana Boston, to create her

book *The Patchworks of Lucy Boston* in 1995. Before that, there was little published or known about Lucy's patchworks and the later edition of Diana's book, published in 2009, came at just the right time for quilters swept along by the wave of interest in all things handmade. It was at this time that we saw the Modern Quilt Guild being formed in the USA, the Quilt Museum in York was into its first year and in 2010 the V&A held its landmark exhibition *Quilts 1700-2010*. For a new generation of quilters, it was a feast of inspiration and since then quilters around the world have been fervently rediscovering English paper piecing (aka mosaic and EPP) and the joys of hand stitching.

It starts with a stitch

Lucy's first patchworks were made in 1938 when she was living in Cambridge and she made a curtain and a throw for her sofa using large hexagons arranged into rosettes. It was after the move to The Manor, Hemingford Grey, that she really started to stitch on a regular basis and her legacy is a collection of 22 quilts made over 50 years, with increasingly

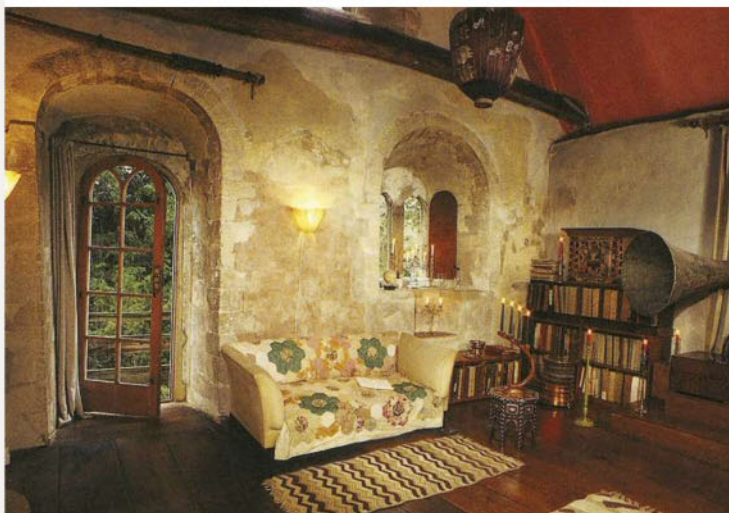

Above, The Music Room at The Manor showing Lucy's hexagon throw
Left, Nancy Adamek from Lina Patchwork's Little Lucy quilt is a lovely tribute to the original Patchwork of the Crosses; **Far Left**, The children's room at The Manor, Hemingford Grey with Kate's Stars patchwork on the bed made for Lucy's first granddaughter Kate



complex designs achieved through a clever and intuitive use of pattern and fussy-cutting. All of her patchworks are made using paper piecing. When Lucy died in 1990, her son Peter and his wife Diana decided to open The Manor to the public. This allowed visitors to experience the magic of *Green Knowe* (the imagined home in Lucy's novels based on The Manor), its wonderful garden and of course,

“Her legacy is a collection of 22 quilts made over 50 years, with increasingly complex designs.”

the patchworks. Since opening the house to the public, Diana has discovered that, “the interest in the patchwork collection is always tremendous even from those who have never been patchwork enthusiasts”. With this in mind, she decided to create a permanent record of Lucy's patchworks and wrote her book, sharing insights into Lucy influences such as the renowned patchworker Averil Colby; her techniques (no less than 20

stitches to the inch); her painterly approach to using fabrics; and her clever use of fussy-cutting that went beyond anything that had ever been done before.

“It is a fallacy that in patchwork any colour goes. The pleasure of the work comes from using one's own choice of colour for each two little pieces one sews together, as a painter would.”

(extract from an introduction written by Lucy Boston for her one and only exhibition of patchworks organised by Christopher Hogwood at King's Lynn in 1976).

The legacy lives on

In 2006, Canadian quilter, author and teacher Linda Franz read Diana's book and was captivated by Lucy's ingenious designs. She was inspired to create her best-selling pattern book, *Lucy Boston, Patchwork of the Crosses*, which introduces quilters to her “Inklingo” technique, an alternative to paper piecing and a game changer for quilters who want to get straight down to sewing.

For quilters preferring to use the traditional method of paper piecing, UK-based Lina Patchwork are a new and growing business specialising in the manufacture and supply of pre-cut paper pieces and templates for English paper piecing, including the elongated hexagon (honeycomb shape) used in the Patchwork of the Crosses. For those who love to follow a block-of-the-month; quilter, designer and shop owner Jessie Fincham continues to run a BOM club dedicated to the Patchwork of the Crosses, where a curated collection of Liberty Fabrics is delivered complete with templates and instructions straight to your door every month. We are thrilled to include a picture of Nancy Adamek's Little Lucy quilt (Lina Patchwork) and details of Jessie's new Patchwork of the Crosses BOM Club for 2017 (see left).



THE PATCHWORK OF THE CROSSES BOM CLUB 2017

It's not too late to sign up with Jessie Fincham for her 2017 BOM club using Liberty Tana Lawn fabrics! Sign up closes on 19 January, so be sure to visit the website and register your interest as soon as possible! For more info, visit www.sewandquilt.co.uk



There are many extraordinary aspects of Lucy Boston's life that you will discover during your visit to The Manor and in Diana Boston's book. She single-handedly managed the restoration of a substantial historic house and garden in her 40s, a prolific author in her 60s and a passionate stitcher well into her 90s – these achievements were not without their challenges. She created stunning, complex patchworks with the most rudimentary of tools and most of her hand stitching was done in a very dark dining room without the benefit of dainty hands and magnifying lights. Her design wall was her floor or the double bed in the spare room, and her patterns were completely organic and evolved from a naturally artistic approach to everything that she did.

It is both uplifting and inspiring to know that the beautiful and magical place in which she dwelled – physically, spiritually and intellectually – with its sensory garden, beautiful quilts, and the rich imaginary world of Green Knowe, was entirely of her own creation. For quilters just discovering Lucy Boston for the first time, there is much to enjoy and if 2017 is the year to start your paper piecing projects, I can't think of a better place to start. 🍷

LINDA FRANZ

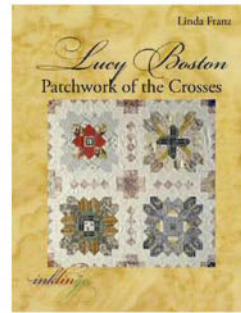

“Ten years ago when I read Diana Boston's beautiful book, *The Patchworks of Lucy Boston*, it was love at first sight. I was fascinated by Lucy Boston's life story and I was inspired by her brilliant way of using simple shapes with elegant fussy-cutting. I realised that the Inklingo method of printing on fabric was the perfect way to make her designs accessible to more quilters, especially those who would not normally consider English paper piecing because it is slow or too hard on their hands. No matter what the design, printing the shapes on fabric with Inklingo allows quilters to get better results in a reasonable amount of time, and offers a choice of sewing by hand or by machine.

“I approached Diana Boston and was thrilled that she agreed and helped me get permission to use Julia Hedgecoe's stunning photographs. When I wrote *Patchwork of the Crosses*, I wanted to honour Lucy Boston's amazing talent and artistic approach to quilting, but I also wanted to offer a simpler method for modern quilters. I am very grateful to Diana Boston for introducing me to the quilts and for her gracious support in helping to preserve the wonderful legacy of an amazing quilter.”

Lina Patchwork



Nancy at Lina Patchwork teaches workshops on the Patchwork of the Crosses and you can also dip your toe in the water by trying out one of their smaller kits for a table runner and cushion based on the POTC pattern. As well as selling Linda Franz' book you can choose to buy from three different sizes of honeycomb shapes and squares as pre-cut papers.

www.lindafranz.com

www.linapatchwork.com



The garden is open daily from 11am to 5pm (dusk in winter). No appointment is needed. The house is open throughout the year, but strictly by appointment.

The Manor, Hemingford Grey, Huntingdon, Cambridgeshire, PE28 9BN

www.greenknowe.co.uk

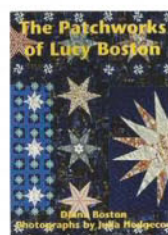

The Patchworks of Lucy Boston is available to purchase for £12.50 + £2 p&p. Within its 120 pages there are chapters on each of the 22 quilts made by Lucy Boston with beautiful photographs by Julia Hedgecoe and illustrations by Peter Boston. For more info and to purchase a copy, email diana_boston@hotmail.com

SUBSCRIBE

Q TODAY'S QUILTER

Create beautiful quilts for your home

Save time and hassle
with an annual
subscription!

Start your
**Free
trial**
today!



GREAT REASONS TO SUBSCRIBE DIGITALLY!

- 1 The latest issue is available instantly
- 2 Receive a further 13 issues in your first year
- 3 All issues download automatically
- 4 Download it once... read it offline forever



iPad is a trademark of Apple Inc., registered in the U.S. and other countries.
App Store is a service mark of Apple Inc.

Perfect for your iPad or iPhone!



START YOUR FREE TRIAL TODAY!

The digital version of the magazine does not always include the cover gift that you would find on print newsstand copies.





ONE-PATCH PROJECT

THE ROSE STAR

*Go large with one block to create
a visually stunning design that isn't
too complicated!*

Designed and made by **CAROLYN FORSTER**
Quilted by **CAROLYN CLARKE**

ONE-PATCH PROJECT
THE ROSE STAR



You will need

- Print fabrics equivalent of twenty-four (24) fat eighths, or twelve (12) fat quarters
- Background fabric – 2yds
- Backing fabric – 3³/₄yds
- Batting – 58in x 79in
- Binding – 1/2yd

Finished size

- 47¹/₂in x 69in

Cutting out

1 From the print fabrics cut as follows for each block using the kite template (see Templates section):

- Six (6) kites from the same print for the flower centre (A).
- Twelve (12) from the same print for the first circuit (B).
- Twelve (12) from the same print for the second circuit (C).
- Twelve (12) from the same print for the third circuit (D).
- Six (6) from the same print for the outer points (E).

2 From the background fabric cut as follows:

- One-hundred-and-eighty-four (184) kites using the template.
- Sixteen (16) half kites to fill in the sides of the quilt.

3 Cut the backing fabric into two equal lengths, remove selvages and join together. Press seams open.

4 From the binding fabric cut six (6) strips 2¹/₂in wide. Join with bias joins and press seams open. Press along the entire length WS together.

BEHIND THE QUILT

THE ROSE STAR

“I loved a Rose Star one-patch block from a 1930s quilt, but I wanted mine to grow a little faster, so I made the Kite template larger than the original. Once you look at the diagrams you will see how simple this block is to make, and you will be off and running in no time. On page 64, you’ll see one block also looks great on its own, quilted and bound as a table centre or a mini quilt for your wall. Work this in seasonal colours and it will be great at Christmas time! This quilt has cotton lawn as the backing to give a lovely silky but snugly feel when you are under it.” – Carolyn Forster

TQ

TECHNICAL TIP

To give you an idea of what you will be able to cut from your fabrics:
 Yield from a fat quarter: twenty-four (24) kites
 Yield from a fat eighth: twelve (12) kites
 Yield from a 3³/₄in x WOF strip from yardage: ten (10) kites.

Fabric used

■ Flower Sugar from Lecien Fabrics.

Notes

- You need five (5) different fabrics per flower. There are six (6) flowers in total; five (5) full and two (2) halves.
- If you choose to fussy-cut you will need to allow more fabric.

Making the blocks

Each hexagon consists of six (6) large triangle sections. The kites are pieced together into small triangles, and then four (4) of these are used to make a large triangle. You may wish to lay the kites out in the hexagon shape before you begin sewing them together. Sew all the kites together in the same way to make the triangles, always pressing the seams in the same direction.

5 Take a matching pair of fabric B kite shapes and place right sides together with raw edges aligned. Sew

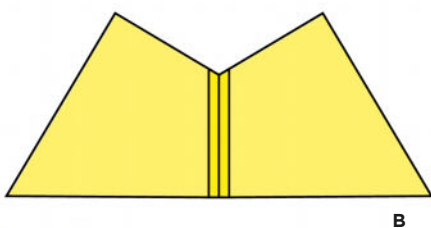
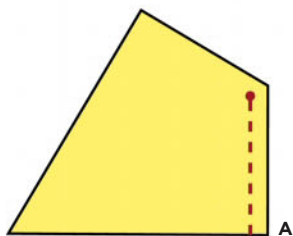

Fig 1

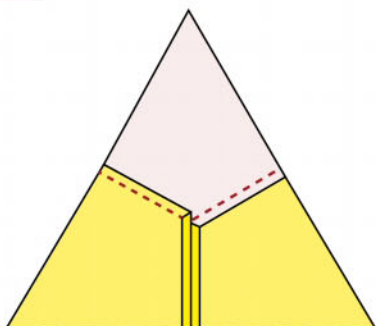

Fig 2



the kites together along a short side, starting at the outside edge on the straight of grain side (**Fig 1A**). Stop stitching $\frac{1}{4}$ in away from the raw edge corner. Press seam open (**Fig 1B**).

6 With right sides together, place a fabric A kite on the sewn kites from step 5, matching raw edges of one short side. With the fabric A kite on the bottom and the pair of B kites on the top, sew from the raw fabric edge to the $\frac{1}{4}$ in point at the open seam. Leaving the needle in the work, lift the presser foot and



TECHNICAL TIP

When you add your third kite to make the triangle, have the pieced unit uppermost so you can clearly see the seam. This will ensure you stop and pivot at the correct point.

pivot the top piece so it aligns with the raw edge of the kite underneath. Lower the presser foot and continue to stitch to the end of the seam. Press one seam up and the other down (**Fig 2**). Repeat to make six (6) matching A/B flower centre triangles.



7 Referring to steps 5-6, use C and D kites to make six (6) more pieced triangles. Repeat again using E and background kites, to make another twelve (12) pieced triangles (**Fig 3**).

8 Place an A/B triangle and a C/D triangle right sides together, matching the centre seam. Sew the triangles together as shown in **Fig 4**. Repeat to make six (6). Press the seam on three of these towards the A/B centre triangle and on the remaining three away from the centre triangle.

9 Sew matching E/Background triangles to opposite sides of a centre unit as shown in **Fig 5** to make a large triangle. Press seams in the same direction. Repeat to make six (6) large triangles.

10 You now have six large sections of triangle to sew into a hexagon. Lay these out so that the seams pressed in different directions are alternating around the hexagon.

11 Sew three triangles together as shown in **Fig 6** to make a half-hexagon. Then sew the remaining three triangles together to make another. Press the seams in the same direction on both. Because of the way you have pressed the seams they will all lock together, for a neat finish. **Do not sew the half-hexagons together.**

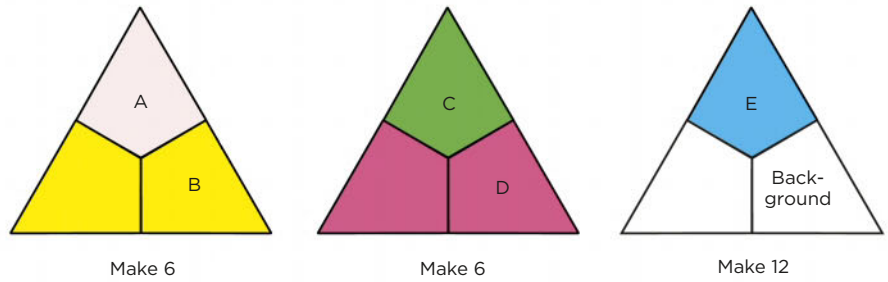

Fig 3

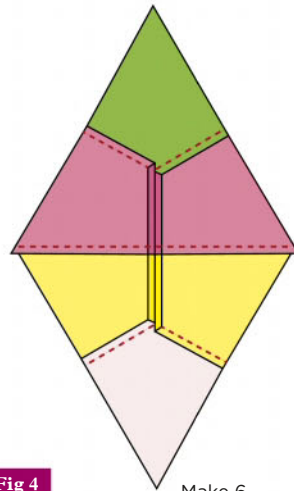

Fig 4

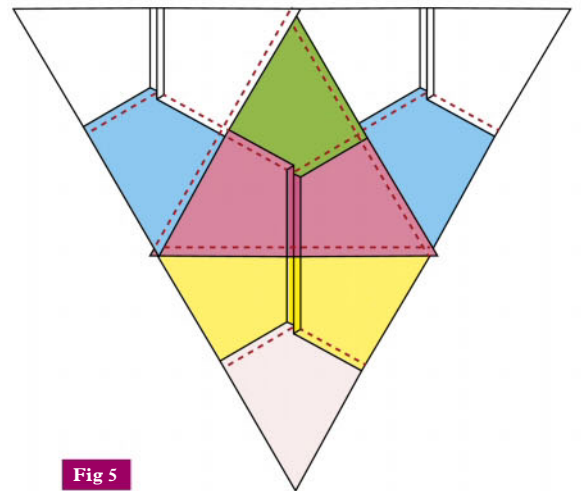

Fig 5

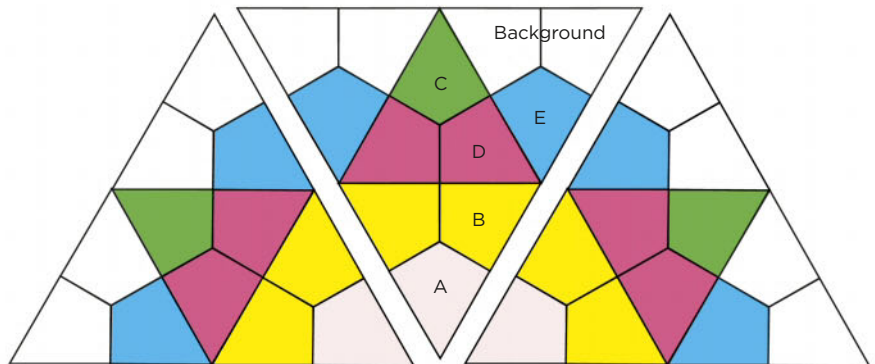

Fig 6

12 Repeat steps 5-11 to make a total of twelve (12) half-hexagons which will make the five full rose stars and two halves (**Fig 7**).

Assembling the quilt

13 When you sew the hexagons together to make the quilt top, you will end up with a big zigzag edge along the top and bottom. To fill them in we need to make setting triangles as follows.

14 First make eight (8) small triangles from the background kites referring to steps 5-6. Press seams as before.

15 Lay out two (2) more background kites and two (2) background half-kites as shown in **Fig 8**. Stitch these pieces together into two half triangles and then attach to the triangle from step 14. Repeat to make four (4) triangles and four (4) reversed triangles (**Fig 9**).

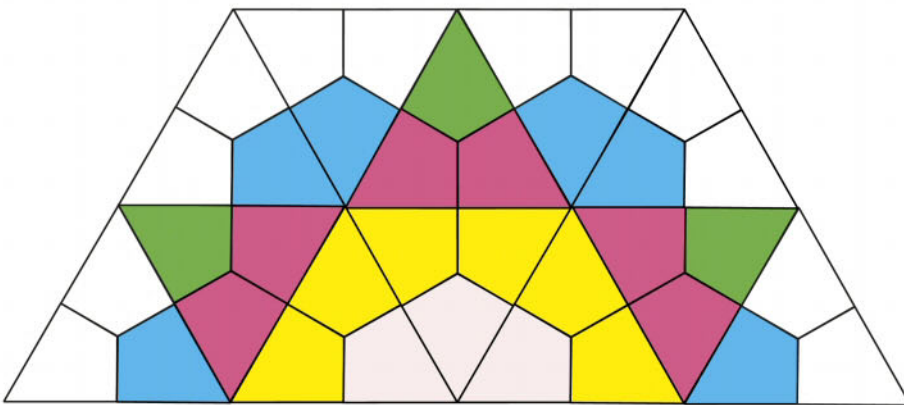

Fig 7

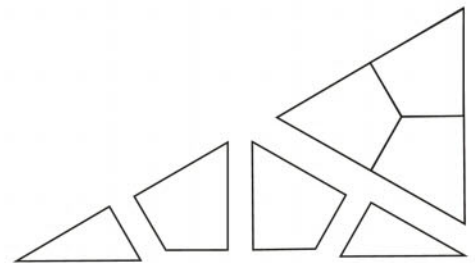

Fig 8

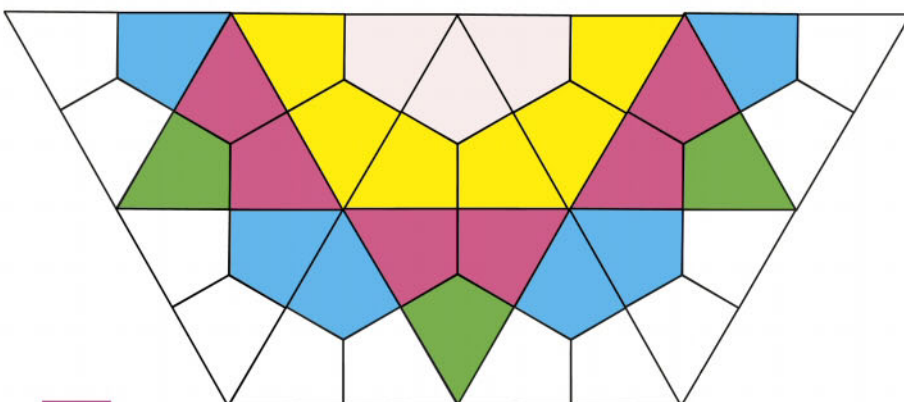
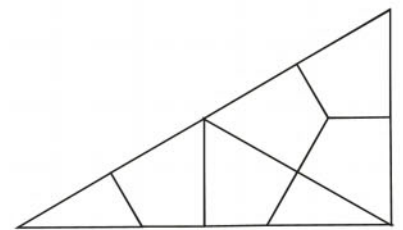
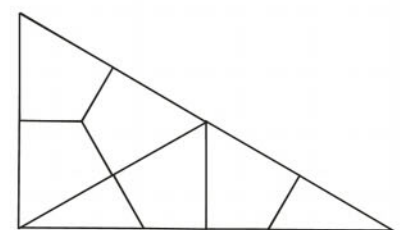

Fig 9



Make 4



Make 4



16 Lay out the half hexagons and side triangles into four (4) vertical rows as shown. Sew the side triangles to the half-hexagons then stitch the half-hexagons together to form the rows (Fig 10). Press the seams open.

17 Then sew the rows together, again pressing the seams open to complete the quilt top.

18 Layer the quilt top with backing and batting and quilt. This one was quilted in an all over vermicelli design on the sewing machine. The example below right is outline quilted in Big Stitch quilting, which is another idea for quilting this project. When quilted, bind and label. 🍷

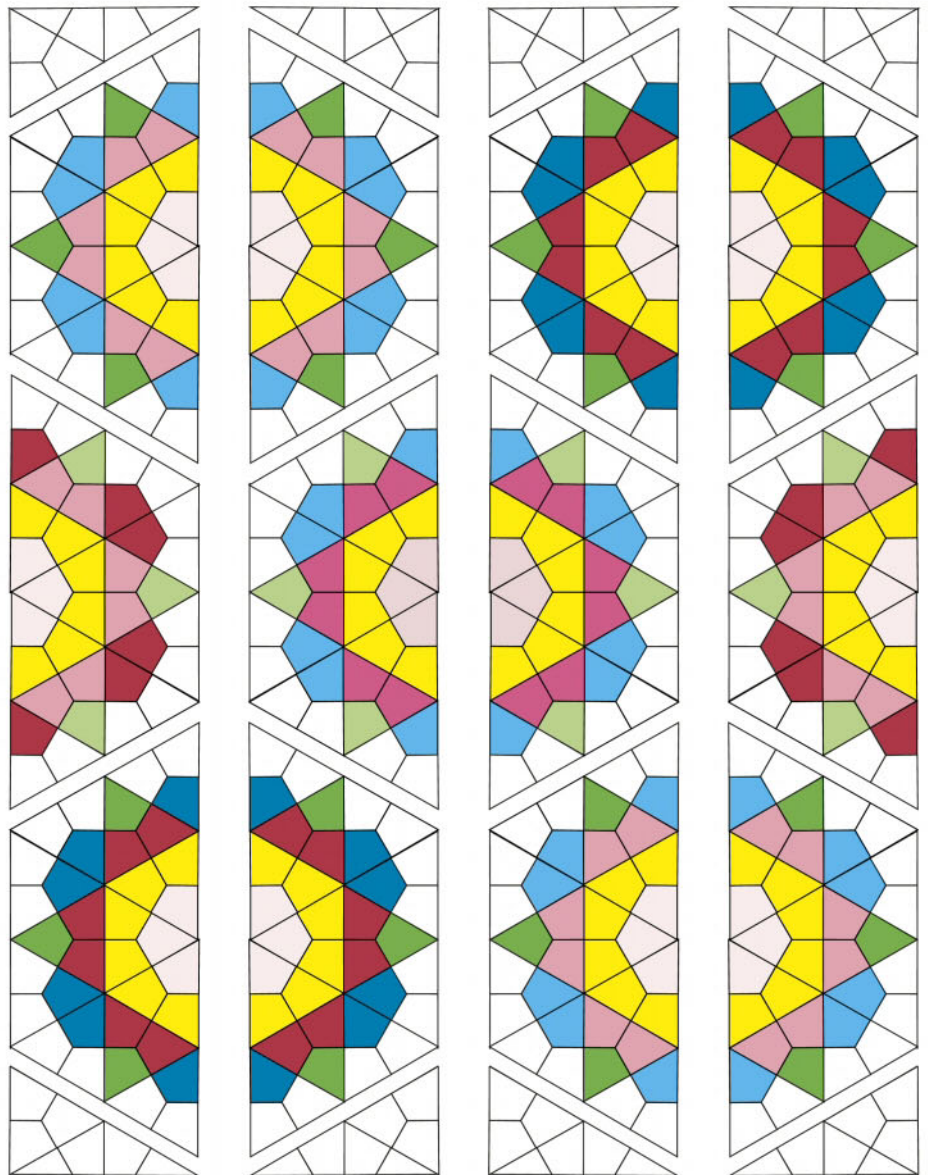

Fig 10



Single one-patch rose star



A single block can be used to make a table centre or cushion. Hand-quilting in big-stitch gives it a lovely finish



Meet the designer

Carolyn Forster has been sewing, making patchwork and quilting for well over 20 years, and teaching for many of those years. You can find her quilts in a range of books published by Landauer Publishing (USA), and Search Press (UK). She blogs at www.carolynforster.co.uk or you can follow her stitching inspiration on Instagram. To get in touch with Carolyn about her classes and talks, you can email her at: carolynforster@hotmail.co.uk

www.carolynforster.co.uk [f](#) [p](#) Carolyn Forster [i](#) [Quiltingontheho](#)

Sleep in a bed of roses...
or at least covered in roses
with this charming quilt

Sewing QUARTER

WATCH IT • LOVE IT • SEW IT

Launching January 2017 on **Freeview 78** 

A **BRAND NEW** TV channel dedicated to sewing & quilting



Join us for:

- Inspiring projects
- Expert advice
- Best offers on fabric & tools



**FREE
Pattern**
(our usual price £7.99)

Find out more and get a **FREE** pattern download
www.sewingquarter.com/freepattern

 facebook.com  twitter.com  instagram.com  pinterest.com

From the makers of

 Sewing
Quarter

 Simply
Sewing

 TODAY'S
QUILTER

 Mollie
MAKES

ESSENTIAL GUIDE

Marking Tools

There are many marking methods available to quilters, but how do you choose which tool to use? This article looks at the pros and cons of the main tools and methods and gives advice on how to get the best results.

No matter what your patchwork and quilting needs, there is bound to be a marking method that will suit



“Marking methods have to be easy to use and reliable, and informed choices will help you choose them and achieve the best results”.

MARKING CHOICES

In patchwork, appliqué and quilting all sorts of lines, shapes and designs frequently need to be transferred or marked onto fabric ready for cutting out or piecing or quilting. There are a wide variety of ways to do this and to begin with here are some things to consider.

- Should the marks you make be permanent or temporary? For example, if they will be covered up by fabric or stitching then it may not matter if they are permanent.
- How can the marks be removed? For example, marks made on a wall hanging that you do not want to wash need to be removed in a way that does not involve full laundering.
- Does the fabric type or colour being worked on matter? For example, some markers don't show up well on dark fabrics.
- Is the project to be marked before or after the quilt sandwich assembly? For example, a quilting pattern crease marked with a needle may not withstand the handling required to make a quilt sandwich and so would be better marked after.
- How long-lasting should the marks be? For example, you may want to mark a quilt top where the marks need to remain visible for many days or even weeks.
- How do markers react with different fabrics? For example, it may be difficult to remove marks, even chalk, from some delicate fabrics such as silk.
- What characteristics does a marker have that need to be borne in mind? For example, some water-soluble marking pens are actually set by the heat of an iron, so you need to remember not to press the work while they are in place.
- How precise do marks need to be?

MARKING TOOLS

There are many tools available for marking, so you are sure to be able to find a marker to suit you. Of course, no single marker will suit all of your sewing needs, so you will need to have a range of tools for different purposes. The most popular marking tools are described here with their pros and cons – so give them a try! We will also look at a few other methods you may not have tried yet. To be on the safe side, *always* read the instructions with a marker to familiarise yourself with its uses and actions, and *always* test a marking method on scrap fabric before you proceed to use it on your project.

TQ

TECHNICAL TIP

Most markers can be used with templates to create interesting shapes for quilting. Try drawing around household objects, specialist rulers and templates, or transferring a simple image.

Creasing Tools

Creasing a line on fabric is one of the easiest ways to mark it. This might just be a simple diagonal line finger creased on a patchwork unit to show you where to stitch. You can also use a ruler and a hera (or point turner) or a large bodkin needle to mark straight lines for quilting. I also find a spoked tracing wheel very handy. This leaves little pinprick marks in the fabric as you push it along. These three tools can also be used to mark gentle curves. Marking is best done on a surface with a little “give” so the tool indents the fabric well.

PROS

- Marks are low-tech and temporary.
- Remove with simple pressing (or not at all).
- Will work on light and dark fabrics.

CONS

- Marks can be difficult to see, especially in poor light.
- Marks can disappear with handling, so are best used on small areas, or in short sequences.

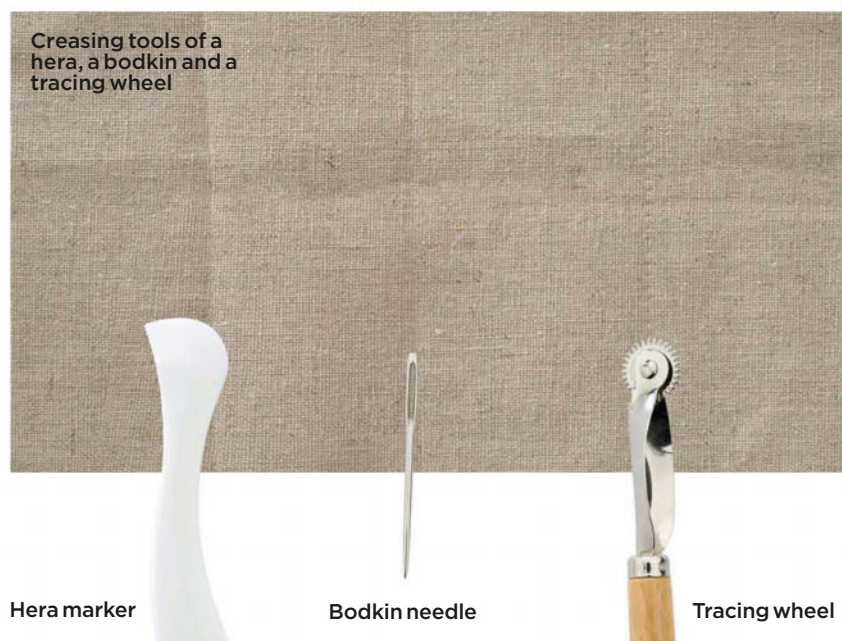

Hera marker

Bodkin needle

Tracing wheel

Chalk Markers

Chalk is a traditional method that remains very popular, particularly for dark fabrics. It is available in various forms and colours, including chalk pencils, chalk blocks and as a powder distributed through a pen or wheel (such as a Chaco liner). Perforated paper and chalk powder can be used in a technique called pierce and pounce, where chalk is pushed through holes in the paper.

PROS

- Marks are temporary.
- They can be removed with brushing (or a firm smacking!) and also by laundering.
- Different chalk colours can be used to suit the colour of fabric.
- Marks can be straight or curved.

CONS

- Marks can disappear with handling, so are best used on small areas, or short sequences.
- Some chalk colours, such as red and blue, can be difficult to remove completely without washing.
- Some chalk markers don't give a very fine line, which might be important for detailed marking.

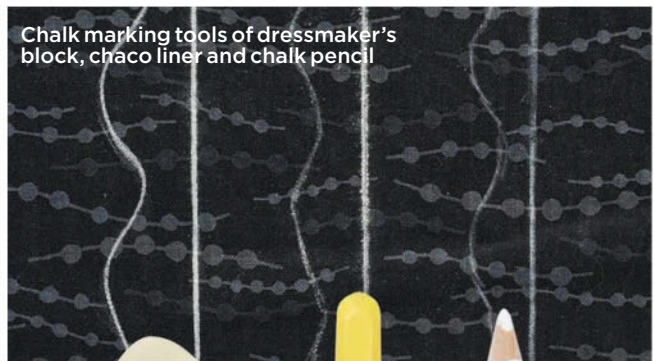

Chalk marking tools of dressmaker's block, chaco liner and chalk pencil



Dressmaker's block



Chaco liner



Chalk pencil



Chalks come in a range of shapes and colours



Sample block marked up with chalk markers

Masking Tape

Low-tack masking tape is ideal for marking straight lines, which may be for sewing or for quilting. Once the tape is stuck into position on the work you can sew or quilt along the edge of the tape (see Fig 1). Different widths of tape can be useful for quilting parallel lines. Quilter's tape is available in a 1/4in seam width.

Fig 1 Sewing along a masking tape edge

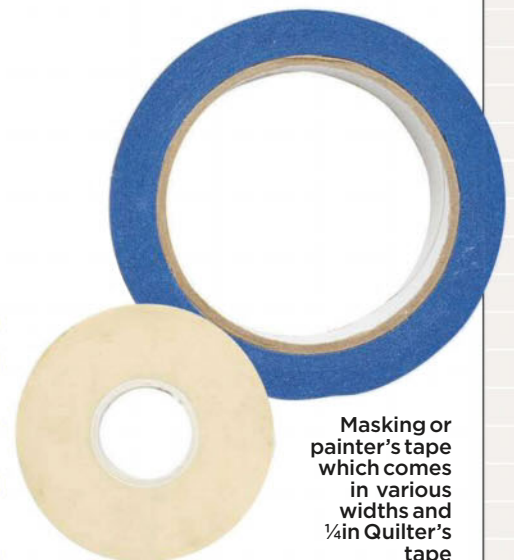
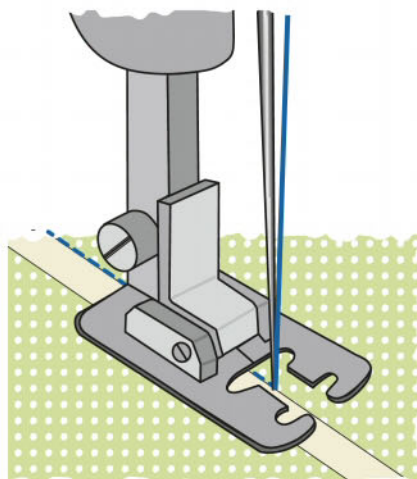

Masking or painter's tape which comes in various widths and 1/4in Quilter's tape

PROS

- No actual marking is needed as the edge of the tape becomes the line to be followed.
- Tape is easy to remove.
- Different widths can be used for different parallel lines, handy for quilting.

CONS

- Some masking tapes can leave a sticky residue, so use a low-tack one and remove as soon as possible after use.
- On thinner fabrics, removing the tape can dislodge threads from the edge of the fabric, causing fraying.
- Care needs to be taken not to sew onto the tape itself.
- Only straight line marking is possible, not curves.



Masking tape used to mark a diagonal line for a corner triangle

Pencils

A normal pencil is probably the marking tool we all use the most. A hard pencil is ideal for marking a fine, clean line around templates and a slightly softer pencil can be used to mark patterns for machine quilting. Fabric erasers can help with mark removal. Watercolour pencils can also be used for marking and have the advantage that the colour can be chosen to show against most fabric colours. Pencils called quilter's or dressmaker's pencils, which have a wax content, are available in certain colours.

PROS

- Marks can be made freehand with pencils or used with a ruler or template.
- Many colours are available.
- Pencil marks can usually be removed with erasers or washed out during laundering.
- Machine quilting marks may not need to be removed if the sewing line covers them.

CONS

- Normal drawing pencils do not show up well (or at all) against dark fabrics.
- Using pencils can stretch or fray edges of fabric (see Troubleshooting page 72).
- Wax-based pencils may need washing to remove them.
- Pencil leads can be difficult to sharpen to a fine point without breaking or crumbling.

Various pencils used for marking, including a normal graphite pencil, a watercolour pencil and a fabric pencil with special leads



Chalk pencil Quilter's pencil Watercolour pencil Normal pencil Fabric pencil

TO

TECHNICAL TIP

Clover has a product called mesh transfer canvas. The mesh is placed on the design and traced with a pencil. The mesh is then placed on the fabric and the design is re-drawn following the tracing. The design isn't too intrusive as it appears as a dotted line on the fabric. The canvas can be wiped clean and re-used.



Dressmakers' Carbon Paper

Carbon paper is useful to transfer fairly elaborate designs to fabric. Marks can be removed by washing but it would be best to check this on a sample first. If you are in any doubt then use it on items where the lines will be covered by stitching. The paper is available in sheets of different colours, including white, yellow, red and blue, which means it can be used on various colours of fabric. To use, place the coloured side of the paper face down on top of the right side of the fabric and use a hard pencil to firmly draw the design, checking carefully to see it is transferring clearly (Fig 2).

PROS

- Different colours of carbon paper produce coloured lines, to show up on a variety of fabrics.
- Marks can usually be removed by washing.
- Designs transferred can be quite elaborate and organic.

CONS

- The design being traced needs to be kept very still on the fabric to produce a clear image and avoid smudges.
- Designs must be drawn firmly to transfer the marks.
- Not very effective on uneven fabrics like wool or slubbed linen.
- Avoid using an iron on the paper.

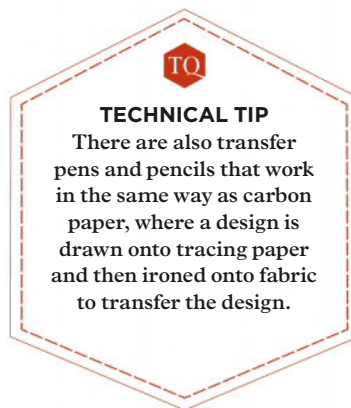
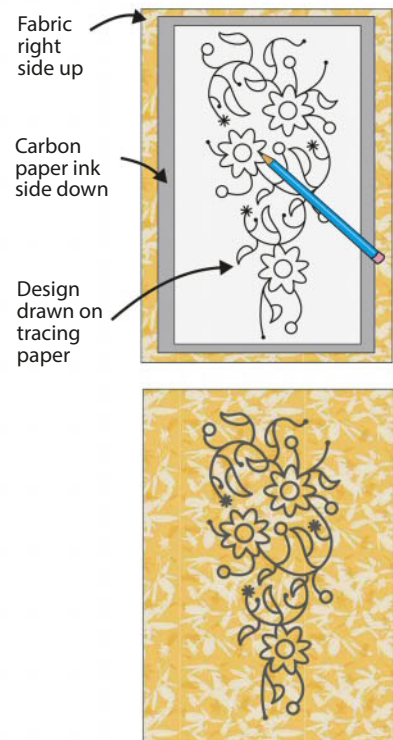

Fig 2 Using dressmaker's carbon paper



Pens

There are many types of marker pens, both temporary and permanent, and the sort you choose depends on your project and personal preference. Temporary (removable) marker pens include water-soluble, air-fading and iron-off. Some water-soluble markers will be set by the heat of an iron, so care needs to be taken to avoid this. Air-erasable markers may not stay in place long enough to complete a larger project, so will need to be refreshed. They work well with quicker projects. It is advisable to rinse finished projects in cool water, as the long-term effects of fabric markers are not yet known. Permanent fabric pens are useful for including text in a project and for writing labels for quilts. Iron-on transfer pens are also permanent and are available in a range of colours.

PROS

- Pens can be temporary or permanent.
- Pens with different methods of removal are available.
- Marks drawn with pens can be in variable thicknesses.
- Fine, permanent pens are useful for text on a project.

CONS

- Some pens don't show up well on dark fabrics.
- Water-soluble markers can require much more than a dab of moisture to remove them.
- Some markers are set by the heat of an iron so care must be taken to avoid this.

- Air-erasable markers may not remain in place long enough, or conversely may not fade.
- Some pen leads are fine and can drag on fabric.
- Some markers can dry out quickly and become useless.

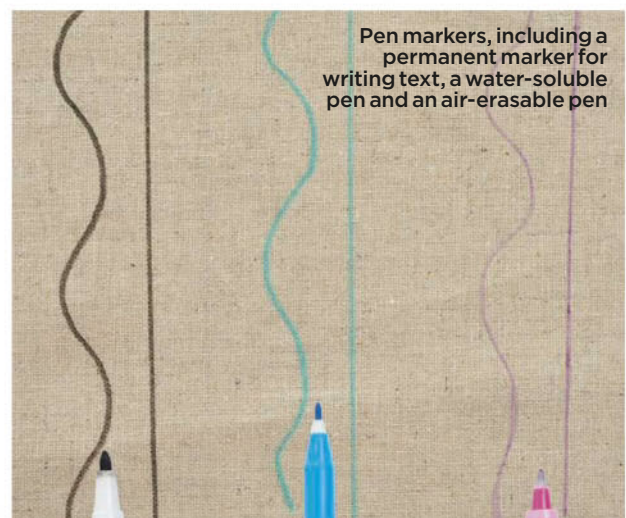

Pen markers, including a permanent marker for writing text, a water-soluble pen and an air-erasable pen

Permanent marker Water-soluble pen Air-erasable pen



MARKING TOOLS – TROUBLESHOOTING

Here are answers to some questions about marking methods.

HELP! I find that using a pencil to mark a diagonal line on a fabric square often pulls at the corners and stretches them. Is there a way to avoid this?

Try this... Pencils and pens with fine leads can drag the threads at a corner and distort the fabric or even dislodge threads if the fabric is a thin or loosely woven one. I find the easiest way to avoid this is to begin the marked line with a firm dot “twirled” in place using the point of the pencil (Fig 3). I then mark the line starting about 1/4in away from the dot, stopping about 1/4in from the end and finishing with another dot.

Fig 3 Avoiding frayed corners when marking

Start with just a dot in the corner

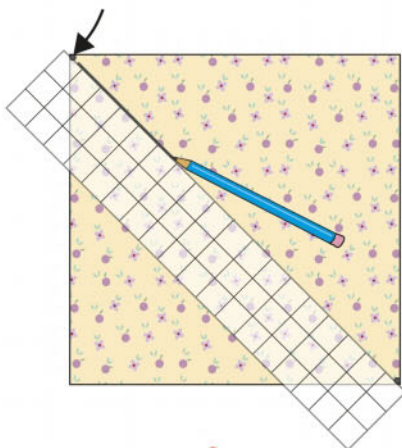

TQ

TECHNICAL TIP

Using a pencil or pen at a slightly more horizontal angle, rather than completely upright, can help to avoid drag on fabric.

HELP! I like using water-soluble markers but sometimes after I’ve removed them there is still a faint blue mark left. What’s the best way to sort this?

Try this... I, too, have had this blue “bloom” left on fabric, particularly on pale ones. The marks are meant to be removable with a damp sponge or a moist Q-tip but the ink can still bleed and spread, much like watercolour paint does. I find a better way is to spray the area with cold water using one of those garden spray bottles, getting it quite wet. I then blot really well with white kitchen paper. The project can be left to dry naturally, or use an iron if you want to continue working.

Note: Some quilters report marks from air and heat-removable pens returning. Always perform your own marker tests on your own fabrics if in any doubt.



Blue bloom remaining from a water-soluble marker after quilting and mark removal

TQ

TECHNICAL TIP

An old method of marking that works surprisingly well is a sliver of soap. Save pieces that have been worn quite flat and with a sharp edge and allow them to dry out before use. Use for straight lines, simple geometric shapes and gentle curves.

About the designer

Linda Clements is a leading technical quilting expert, editor and writer who, for 25 years, has worked on many fabric and craft titles for David & Charles and other leading craft publishers. Among the many quilters who have trusted Linda to ensure their books are both accurate and reader friendly, are Lynne Edwards MBE, Susan Briscoe, Pam & Nicky Lintott, Pauline Ineson, Mandy Shaw and Lynette Anderson. Linda’s own book, *The Quilter’s Bible*, is the must-have guide to patchwork, quilting and appliqué, and includes everything she has

learnt working with the industry’s best designers. For *Today’s Quilter*, Linda is working with the team to select practical and creative techniques. She will then go in depth, exploring the methods, taking them from the basic premise to their full technical and creative potential. You can cut out and keep this section to build your own bespoke technical handbook.

ESSENTIAL GUIDE NEXT ISSUE:

Quilt Labelling: In the next issue we look at how you can add labels to your quilts

TRY 3 ISSUES FOR JUST \$10

when you subscribe today!



SPECIAL OFFER!

- ✓ TRY 3 ISSUES FOR JUST \$10, THAT'S A SAVING OF OVER \$28*
- ✓ SUBSCRIPTION PRICES INCLUDE DELIVERY
- ✓ NEVER MISS AN ISSUE - 13 ISSUES A YEAR

Order now! Don't miss out!

UNITED STATES: Try 3 issues for \$10 and then pay just \$27.49

by quarterly continuous credit,

or pay \$101.99 for 13 issues (1 year subscription),

save 40%, US readers subscribe online at

www.imsnews.com/todaysquilter-a018

OR CALL TOLL-FREE ON 1 800 428 3003 AND QUOTE A018

EUROPE: £76.99 - 1-year debit/credit card

REST OF WORLD: £94.99 - 1-year debit/credit card

Visit www.buysubscriptions.com/tqui or call +44 (0)1795 414 861 and quote TQP18

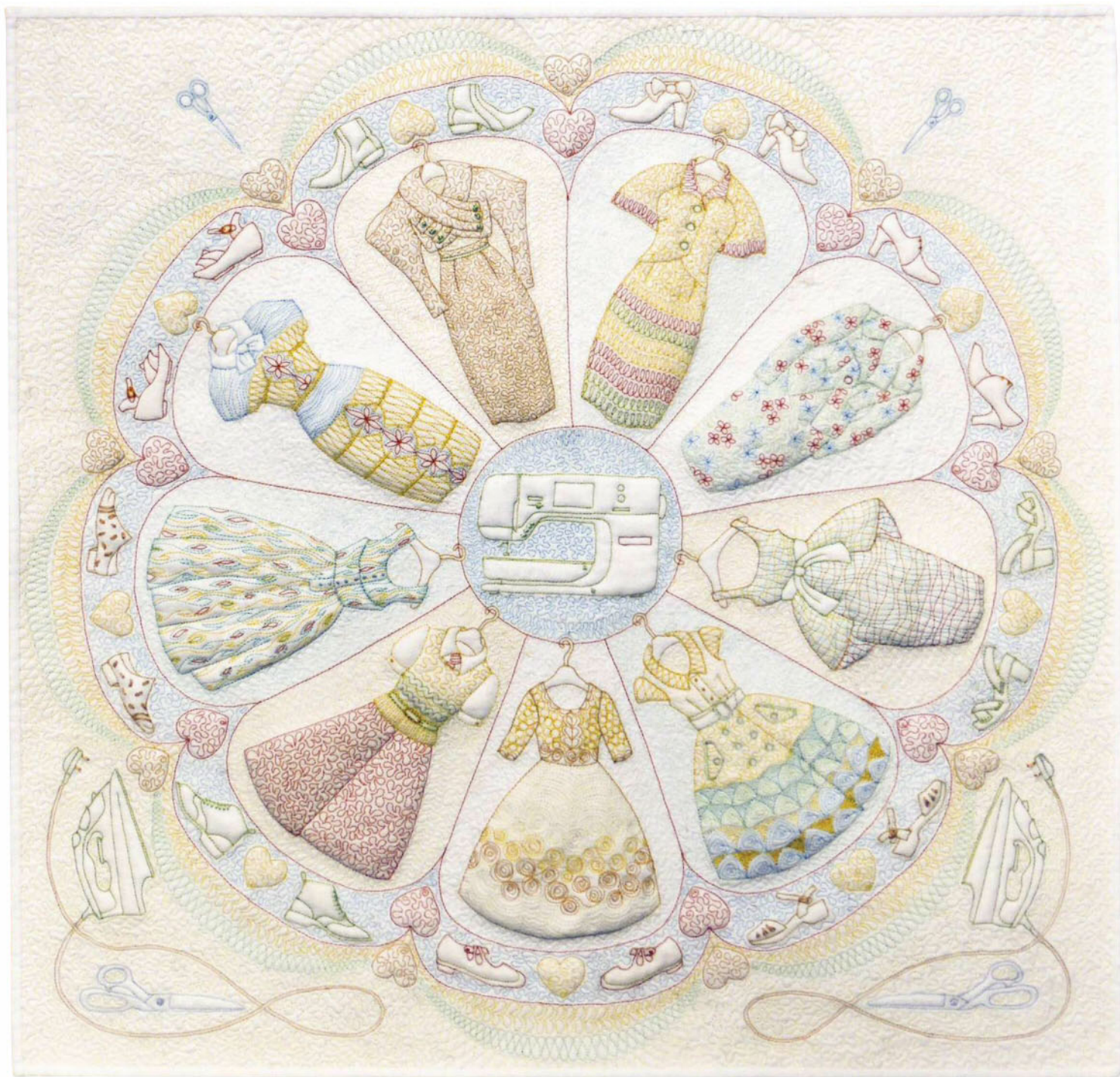

quilt as desired

PHILIPPA NAYLOR

This issue Anne Williams talks to Philippa Naylor to find out more about her fabulous machine quilting.



Above & left, Wearable Art. This quilt won third prize in the Miniature category at The Festival of Quilts 2016. Philippa says, "This little quilt shows a selection of some of my favourite things." **Right**, Scarlett's Crimson. Inspired by ball gowns of the 1950s this design came second in the Quilt Creations category at The Festival of Quilts 2013.



Philippa Naylor has won umpteen awards for her quilting, both in the UK and the United States. She also has three quilts in the prestigious collection at The National Quilt Museum in Paducah, KY, USA. I was thrilled to have the chance to chat with her about her work and to pick up some valuable tips.

10 When did you start machine quilting and how did you learn?

"From 1989 to 2004 we lived in Saudi Arabia, where my husband was working. Women weren't allowed to work so I had a lot of time on my hands. By chance I met someone who suggested I attend a short quilting course. I absolutely loved it and quilting soon became all-consuming. I taught myself to free-motion quilt by stippling everything! Although I had never quilted before, trained as a clothing designer I was an experienced sewer and had lots of technical knowledge, so it was just a case of learning slowly and steadily. I borrowed the few books that were in the library, and joined both The Quilters' Guild and the American Quilter's Society, but other than that had little exposure to quilts during the time we were away from the UK."

10 Are you interested in the history of quilting and do historical pieces influence your designs?

"I'm interested in both the history of quilting and of costumes. I regard my quilts as contemporary and in this 'category' it's easy to identify the origins of the designs and methods used. If you know where things come from then you have an understanding of traditions and techniques, which is a sound basis from which to develop new twists."

10 What captivates you about free-motion quilting?

"As well as the stunning visual effects that can be created with the quilted stitch I love the process. It gives me enormous pleasure to be fully immersed in a piece of work, from the design and preparation through to the hours spent quilting – I'm wedded to my sewing machine!"

10 What are the design sources for your patterns and how do you develop them?

"Many of my designs are autobiographical. As well as creating unique patterns I think sharing things that matter to me gives my work integrity. I'm a keen gardener and love to spend time in our allotment, so you'll see lots of quilted patterns reflecting this passion."

10 When do you consider the quilting pattern in the quilt design process?

"For wholecloths the quilted design is the starting point and you need a master pattern that can be marked onto the fabric. But I draw outlines of only the main elements; the patterns for filling them in evolve as I work. For pieced and appliquéd quilts I think about the quilting once the top is done. I don't think you need a plan or that you need to work out everything at once. I start in the middle and then when I've quilted the first section I stand back and look at it, then I'll move on to the next section and so on. If I'm not sure how to quilt the next section then I'll leave it, think about it and go back to it. It can be like pulling teeth sometimes, but I believe that if you let the design evolve as you go along then it has more personality. If necessary I will unpick as it's important to be precise! As well as attractive individual motifs, the design as a whole must be balanced or the finished quilt won't look harmonious."

10 How do you draft your quilting patterns?

“I draw my patterns in pencil freehand onto paper. I then cut out the motifs and arrange them into a pleasing composition. I then trace this design onto paper, and then transfer it onto the quilt top.”

10 What are your preferred fabrics and do you have a favourite type of wadding?

“I use fine high-quality cotton lawn or cotton poplin. Cotton lawn has a high thread count and a delightful silky feel. Cotton poplin is tightly woven and less prone to wrinkling than cotton. If I’m hand-dyeing fabric, I’ll use the same base fabric throughout so that all the cloth has the same ‘handle’. I use the same type of fabric on the quilt back. As well as being a pleasure to work with, lawn and poplin don’t stretch, and when doing tiny stitch work the needle doesn’t jump. I use 50% cotton/50% polyester blended wadding, which is firm and felt-like – as I’m making my quilts for exhibition it’s vital that they are flat and hang well. I pre-shrink the wadding by soaking (not washing) and spinning it; it does shrink quite a bit! This makes it softer, so when making the quilt sandwich the layers ‘stick’ together and when quilting it’s easier to needle. Also, the folds seem to drop out better if the wadding has been pre-shrunk, so this is another advantage as my quilts will be folded and transported several times.”

10 How do you transfer the quilting designs onto the quilt top?

“On lighter fabrics designs are marked with a fine propelling pencil. For darker fabrics I use a Sewline mechanical pencil for fabrics. I mark a solid line, which I stitch directly on top of.”

10 How do you baste your quilt sandwich?

“I layer my quilts on the floor and baste with 1in safety pins placed in a 3-4in horizontal and vertical grid. I find this the best method with the dense stitching I do as I can remove the pins as I work. It’s also easy to see at a glance which areas I’ve covered.”

10 What type of sewing machine do you use?

“I do my quilting on a Bernina 7 Series sewing machine, a domestic machine with an extra-long free-arm. I don’t use a hoop when I quilt, just a bit of non-slip mat (the sort you use on tea trays) under my left hand.”

10 Which threads do you like to use?

“I’m a huge fan of polyester threads and rarely use cotton. Polyester is finer and stronger than cotton; it also has some ‘give’ so breaks less easily and there’s no lint build-up. When quilting my large quilts, I use 40wt polyester on top, which has a lovely high sheen, and 60wt in the bobbin. For my miniature quilts I use 100wt silk on top, which is extremely fine; it also has



Far left, Sewing Bee and details. A miniature quilt that reflects Philippa’s love of her garden. The close-ups show the wonderfully detailed stitching and the use of different coloured threads; **Above & left, Flower Power:** a fabulous wholecloth featuring free-motion quilting and trapunto. The asymmetrical design is beautifully balanced. The close-up shows the areas raised by trapunto and the gorgeous stitched detail.

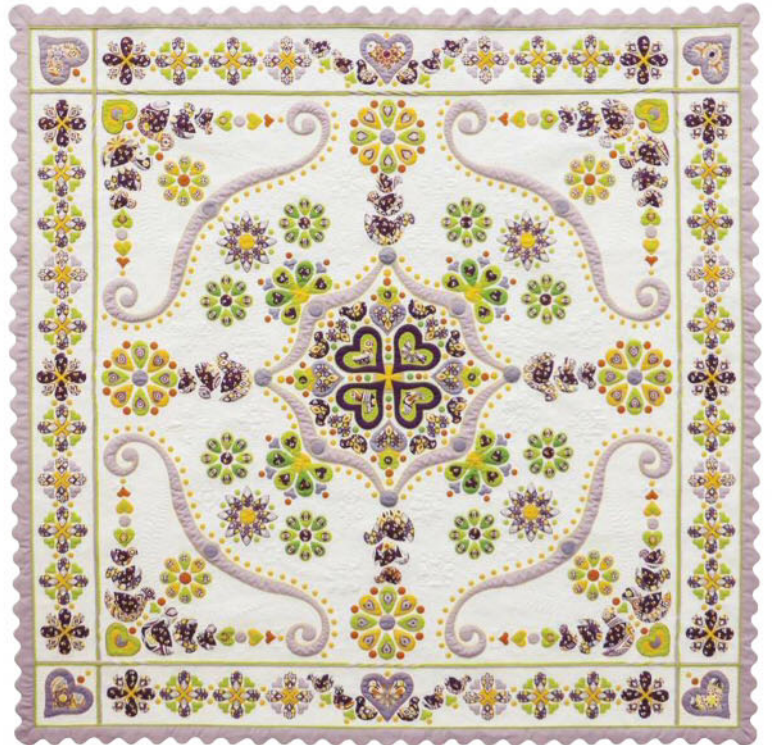

Above & right, Bird by Bird, this appliquéd quilt won first prize in the Traditional category at The Festival of Quilts 2014. In her book *Appliqué Mastery*, through a 12-month programme of instructions, Philippa takes the reader through the wide range of techniques used to make this quilt.

an attractive lustre. Mostly I use solid colours – there’s a massive range to choose from – using several hues in one quilt. If I change the top colour then I change the bobbin one too, so if I use orange on top then I use orange in the bobbin. I use Microtex Sharp Needles in size 60/8 as these have a thin and accurate point.”

10 When and why did you start to utilise trapunto in your work?

“I started to use trapunto early on in my quilting career. I didn’t know how to do it so made it up as I went along, but it really isn’t that difficult. I think this method of stuffed quilting to raise the surface is an under-used method and would recommend anyone to at least give it a go.”

10 Do you know how long it takes you to quilt a piece?

“I don’t keep a time sheet so I don’t know exactly how long it takes me to quilt a piece. But, working very intensively, my last two miniature quilts each took me six to eight weeks to quilt. When necessary, I will put in long hours, often working late into the night.”

10 Has entering competitions pushed you to progress your work?

“Entering competitions is a great motivator for improving your design and technical skills; I’m always trying to come up with something different. It’s important to me that I show high-quality pieces as quilting is my business. For me, entering quilts into shows and winning prizes is how I advertise my work and my classes. My quilts have to go out and work for me!” **10**

You can see more of Philippa’s work, find out about her classes and teaching schedule, and buy her book on her website: www.philippanaylor.com



Philippa’s top tips

Try Philippa’s tips to develop your quilting repertoire

- Start by becoming proficient in stippling. Practise is the only way to hone your skills – there are no shortcuts.
- Everything new you try teaches you something, which you can take forward to your next project. So don’t get stuck in a rut of two or three patterns; work on expanding your quilting vocabulary.
- If you’re stuck for a quilting design and have used prints in your quilt top look for motifs in the fabric/s, which you could use as a starting point, e.g. flowers or circles that you could work into a quilted pattern.
- Once you find a motif you like then play with it to come up with variations you can use in other work. But no matter how stylised it becomes take care to retain balance in the design.
- Don’t worry about not having a plan for how to quilt your top. Just start and see how the design progresses.
- Everybody can free-motion quilt if they really want to – you just have to be persistent and work at it!



Join us next issue when we catch up with award-winning long-arm quilter Sandy Chandler.

TRY 3 ISSUES FOR £5 WHEN YOU SUBSCRIBE TODAY!



Every month in **Love Patchwork & Quilting** magazine you'll discover:

- **Gorgeous projects** for fabric + thread
- **Easy-to-follow** instructions + techniques
- **Exciting ideas** for on-trend homestyle + gifts

BUYSUBSCRIPTIONS.COM/LPQHA17

OR CALL 0844 576 7854* QUOTING LPQHA17

Lines open 8am-8pm weekdays, 9am-1pm Saturdays



LovePatchworkandQuilting



@LoveQuiltingMag



LoveQuiltingMag



LoveQuiltingMag

Terms and conditions: This trial offer is for new print subscribers only subscribing by Direct Debit. You will receive 3 issues for £5 and then continue on a 6 monthly Direct Debit of £24.49 thereafter. Full details of the Direct Debit guarantee are available on request. Prices correct at point of print and subject to change. Offer ends 31st December 2017. *UK calls to 0844 numbers will cost 7p per minute plus your telephone company's access charge. Mobile charges may vary.

SCRAPS PROJECT

HALF-INCH NEEDLE BOOK

*It's easy to get great results with
the tiniest scraps with this
quickly pieced needle book.*

Designed and made by **ALI BURDON**



SCRAPS PROJECT
**HALF-INCH
 NEEDLE BOOK**



You will need

- Twenty-five (25) fabric scraps (at least 1in square) for the centre panel
- Linen fabric – 10in square for body of needle book
- Wool felt – 5in x 7in piece
- Fusible fleece – 4in x 10in*
- Light/medium iron-on interfacing – 5in x 15in**
- Set of coordinating Kam snaps or a sew-on press stud
- Baking parchment

Finished size

- 3½in x 4in approx.

BEHIND THE PROJECT

SCRAP BUSTING

Never ones to waste any fabric, even the tiniest scraps, this project is perfect as it uses the smallest of pieces to make a super sweet and useful object that makes a great gift for a friend... or yourself!

Cutting out

1 From the scraps cut twenty-five (25) 1in squares.

2 From the linen fabric cut as follows:

- Two (2) 1in x 3in pieces.
- Two (2) 1¼in x 4in pieces.
- Two (2) 1½in x 2¼in pieces.
- One (1) 4in x 4½in piece.
- One (1) 4in x 8½in piece.

3 Cut the felt into two pieces measuring 2½in x 7in.

4 From the fusible fleece/batting cut:

- One (1) 4in x 8½in piece.
- One (1) 1½in x 2¼in piece.

5 From the iron-on interfacing cut:

- One (1) 5in square
- One (1) 4in x 8½in piece
- One (1) 1½in x 2¼in piece

Making the patchwork

6 Mark a 1in grid on the non-sticky side of the iron-on interfacing (the smooth fabric side). A soft pencil is ideal for this (**Fig 1**).

7 Lay out the 1in squares in your chosen arrangement on your work surface. Starting in one of the corners, take the few squares from your arrangement, and lay them on the sticky side of the interfacing, aligned with the grid lines. You may need to hold it up to the light to see the markings. Very carefully, using baking parchment to protect your iron, iron these onto the interfacing (**Fig 2**). Complete with the rest of the scraps to cover the entire grid (**Fig 3**).

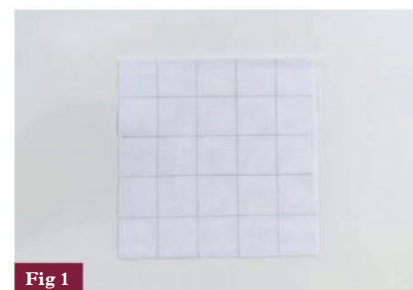

Fig 1



Fig 2



Fig 3

8 Make a fold along the first grid line, then stitch a scant ¼in seam from the fold (**Fig 4**). Cut along the fold, leaving a seam allowance of a generous ½in and then press open.

9 Repeat with the next grid line, cutting and pressing open as before, (**Fig 5**). Continue until you have completed all the parallel grid lines (**Fig 6**).

Fabric used

- Liberty fabric provided by Duck Egg Threads (www.duckeggthreads.co.uk), wool felt and Essex yarn-dyed linen from Cloud Craft (www.cloudcraft.co.uk), Kam snaps from Plush Addict (www.plushaddict.co.uk).

Notes

- Seams are $\frac{1}{4}$ in throughout.
- We used Kam snaps to make the fastening, but a press stud will work just as well.
- *Or batting of your choice, we used Vilene H640.
- **We used Vilene G700.



Fig 4



Fig 5

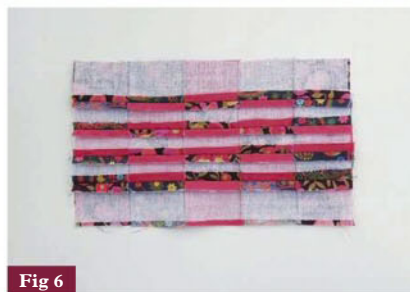

Fig 6

TQ

TECHNICAL TIP

Various designs can be made in the patchwork grid using contrasting solids or prints. Ali chose a solid pink chequerboard diamond shape. Other ideas include a cross, heart or a simple box. Shade a paper mock-up of your patchwork with coloured pencils to try out your own designs.

10 Fold, stitch, trim and press the first grid line in the other direction (**Fig 7** and **Fig 8**). Repeat for all the other grid lines. The finished patchwork panel should measure 3in square.

Making the needle book exterior

11 Take the two (2) 1in x 3in linen pieces and stitch to the top and bottom of the panel, and press seams to the side (**Fig 9**).

12 Take the two (2) $1\frac{1}{4}$ in x 4in linen pieces and stitch to each side of the patchwork and press seams to the side (**Fig 10**).



Fig 7



Fig 9



Fig 8



Fig 10



13 Stitch the 4in x 4½in piece of linen to one of the long sides, to create the back. Fuse the 4in x 8½in piece of fusible fleece to the wrong side (following the manufacturer's instructions), and then top stitch around the patchwork centre (on the linen) (**Fig 11**).

Assembling the needle book

14 Apply iron-on interfacing to one of the 1½in x 2¼in pieces of linen, and fusible fleece to the other piece. Mark lines ¼in from the two long sides and one short side on the wrong side of the interfaced piece of linen. Use a curved edge (a cotton reel is ideal) to join the lines and create the shape of the tab (**Fig 12**).

15 Put this piece RST with the other prepared piece and stitch around the marked line. Trim the seam allowance to a generous ⅛in (**Fig 13**).

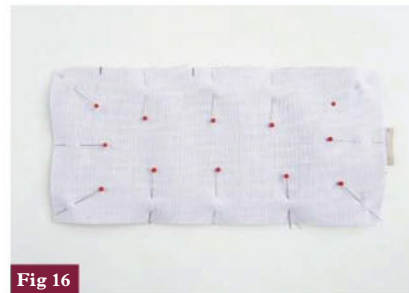
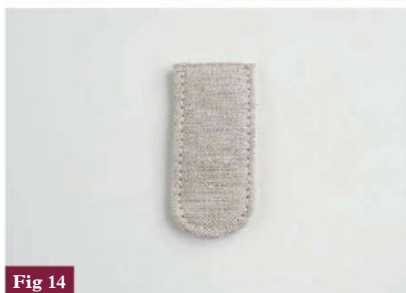

16 Finally turn through, press very thoroughly, and then top stitch around the edge of the tab (**Fig 14**).

17 Apply the 4in x 8½in piece of iron-on interfacing to the same sized piece of linen.

18 Lay the needle book right side up on your work surface, and place the completed tab, as shown in **Fig 15**.

19 Place the interfaced piece of linen on top, RST, sandwiching the tab between them, and pin in place (**Fig 16**). Stitch around the edge, leaving a turning gap on one of the long edges, close to the corner on the back of the needle book. Reverse stitch at either end of the seam, so that when you turn the needle book through the hole, your stitches won't unravel.

20 Clip across all the corners at a 45-degree angle, being careful not to cut through your stitching.



This handy little needle book is great for storing needles and pins so you can sew on the go



Fig 18



Fig 19

Turn the needle book through the hole, and press, turning under the edges of the turning hole. Use a little swish of washable glue, or pin the hole closed, then top stitch around the edge of the needle book, stitching the hole closed as you go.

21 Take the two pieces of felt and align them, one on top of the other, centrally on the inside of the needle book. Pin in place, then, working on the outside of the needle book, stitch to secure, stitching just to one side of the central seam line. Reverse stitch at either end of the seam to secure. Change your bobbin thread to match the felt if you want to (Fig 17).

22 Apply one of the Kam snaps to the tab, as shown, following the instructions that came with your kit. Alternatively, stitch half the press-stud in place (Fig 18).

23 Fold the needle book closed, and squeeze the first half of the Kam snap against the back of the needle book. Use the bradawl that came with your Kam snap kit to make a hole at the centre of the imprint you have just made, and insert the other Kam snap at that point. Alternatively, use the imprint as a guide to show you where to stitch the other half of the press-stud (Fig 19). Remember the popper needs to be on the outside of the back of the needle book. 📌



Personalise the needle book for specific friends using different colours and patterned fabrics

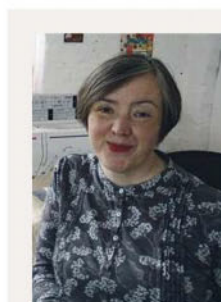

Meet the designer

Ali Burdon lives in north Staffordshire with her husband, twin sons and their dog, Barney, where she does lots of sewing, crochet and baking, the main themes of her website Very Berry Handmade. She also has a small business selling Liberty Tana lawns on her Folksy page, <https://folksy.com/shops/veryberryfabrics>.

🌐 www.veryberryhandmade.co.uk 📺 [veryberryhandmade](https://www.facebook.com/veryberryhandmade)

Crochet Stitch Collection

ONLY
£7.99*



New techniques to learn, beautiful patterns to treasure!

Discover more than **25 gorgeous crochet stitches** in this handy collection of 'how to' guides – then put your new skills into action with over **70 favourite patterns** chosen by the team at *Simply Crochet* magazine. You'll be an instant expert!

ORDER YOUR COPY TODAY!

- **CALL** 0844 844 0388 and quote 'Crochet Stitch Collection'
- **ONLINE** www.buysubscriptions.com/craftspecial

Lines open weekdays 8am to 8pm and Saturday 9am to 1pm. Overseas please call +44 (0) 1795 414 676.

* EUR price £9.99, ROW price £10.99. All prices include P&P. Please allow up to 28 days for delivery.

A Month in the Country
BLOCK OF THE MONTH NO. 4

SNOWFLAKES

Designed and made by
JO AVERY



Fabric shopping taken to a whole new level

It's the middle of winter and I'd like to think that Shangri La Farm is lying under a carpet of pure snow. January is a quiet time of year for me with very little teaching so I don't mind at all if it snows when I know I can stay safe and warm inside.

One of the things I love most about heavy snow is how it reveals all the varied wildlife activity in our fields. Normally we have no idea how many little creatures run around outside at night, but the virgin snow reveals numerous tracks criss-crossing the land from many different feet and paws. We slow down our daily walks so we can study them and we always enjoy

that crisp crunching sound as we contribute our own footsteps.

And then there's that strange quiet that snow seems to bring, especially after dusk when the snow magnifies the moonlight and makes you feel you have entered a magical realm.

To celebrate that special winter magic I've chosen a snowflake as the subject for this month's block. Even though we all know that each one is unique it is still fairly mind-blowing when you think about it!

Jo x

[mybearpaw.com](https://www.mybearpaw.com) [Twitter](#) [Instagram](#) [mybearpaw](#)



Make your own unique snowflake



Some of the wildlife on the farm



The snow covers everything

BLOCK OF THE MONTH
SNOWFLAKES



"Just like real snowflakes, each and every hand-stitched block will be entirely unique – one of the many reasons we love patchwork."

Assemble your block

1 First trace the large snowflake pattern (see Templates section) on to the right side of your background square using a pencil or removable pen. Fold the fabric square in half for a centre guideline. Line up the half snowflake pattern with the centre fold and trace, then turn the pattern around and trace the other half of the snowflake. If you can't see the pattern lines easily through

your fabric try taping to a window, your computer screen with the light turned up, or go over the pattern lines with a thicker pen.

2 Lay the background fabric over your snowflake fabric, right sides up, and pin (**Fig 1**). Using a contrasting thread tack inside the pattern line all the way around the pattern (**Fig 2**).

You will need

For the main block:

- Background fabric – 13in square
- Snowflake fabric – 13in square
- Fine cotton thread to match your background.

For the variation block:

- Background fabric – four (4) pieces measuring 6½in each
- Snowflakes fabric – four (4) pieces measuring 6½in each
- Paper backed fusible web (bondaweb) measuring 12in square



Fig 1



Fig 2



Fig 3

Finished size

- 12½in square (12in once pieced into project)

Notes

- Make one of each block for the quilt, or two of the same if you prefer.



Silver fabric would look really great in this snowflake block

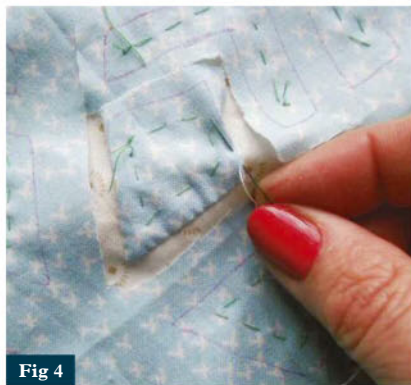

Fig 4



Fig 5



Follow in the footsteps...

Thick coats are a must in the cold

The Tiny Barn's blue paint looks icy in the snow

COUNTRY SNOW PHOTOGRAPHS BY JONATHAN AVERY

3 Using small sharp scissors carefully snip through your background fabric and cut a scant ¼in seam inside a small area of the snowflake shape (Fig 3).

4 Turn under your seam allowance and finger press. Appliqué the background fabric to the snowflake fabric using a tiny neat slip stitch and matching thread (Fig 4). Work your way round the whole snowflake pattern, cutting into the background

fabric and stitching down a small amount at a time.

5 When you have completed the reverse appliqué carefully remove all the tacking stitches and press. Snip away the unattached snowflake fabric behind the background (Fig 5). Trim to a 12½in square.

A different view
MINI SNOWFLAKES



You've got to love these blocks when you can create a flurry of snowflakes while staying warm indoors. Use all four patterns provided, or use just one or two to make a variety of mini snowflakes variations

VARIATION BLOCK

1 Cut your fusible web into four (4) quarters. Using the small snowflake patterns (see Templates section) trace a different snowflake on to the paper side of each piece of fusible web (**Fig 1**).

2 Press one of the fusible web squares, paper side up, on to the wrong side of a snowflake square.

3 Carefully cut out the shape using small sharp scissors (**Fig 2**) and peel away the paper. Place on top of the right side of a background square, fusible web facing fabric. Press to adhere the snowflake to the background.

4 Sew a neat top stitch close to the edge all around the snowflake shape. (**Fig 3** and **Fig 4**).



Fig 1



Fig 2



Fig 3



Fig 4

5 Make the other three snowflakes in the same way. Sew two finished squares together. Then

sew the other two together before joining the two rows to complete your block. Press. 

TEMPLATES

All the templates you'll need from issue 18...

PICKLE DISH DELIGHT

FOUNDATION PIECING TEMPLATE

ACTUAL SIZE

Includes seam allowances

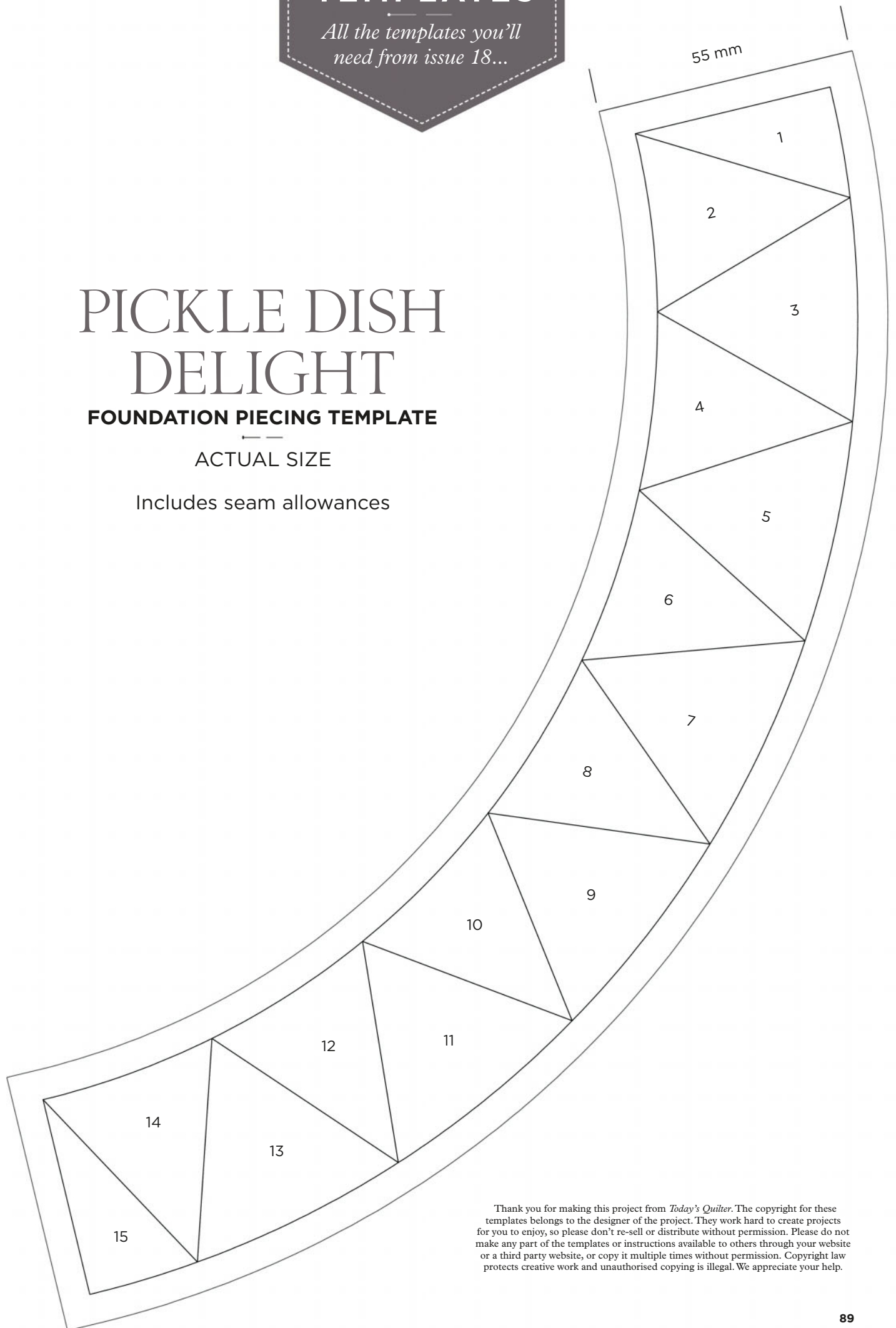

Thank you for making this project from *Today's Quilter*. The copyright for these templates belongs to the designer of the project. They work hard to create projects for you to enjoy, so please don't re-sell or distribute without permission. Please do not make any part of the templates or instructions available to others through your website or a third party website, or copy it multiple times without permission. Copyright law protects creative work and unauthorised copying is illegal. We appreciate your help.

PICKLE DISH DELIGHT

BLOCK TEMPLATES

ENLARGE BY 200%

Includes seam allowances

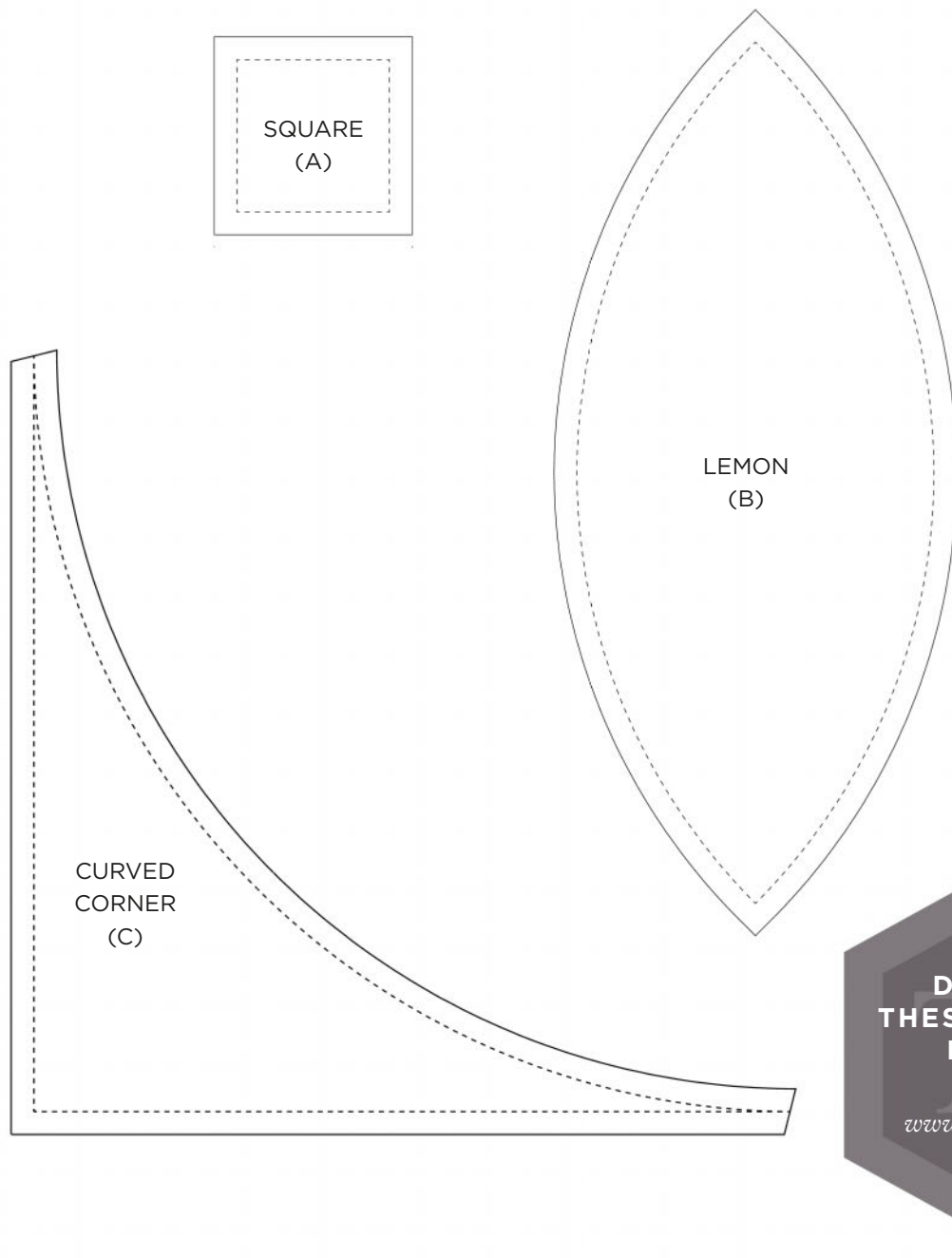

**DOWNLOAD
THESE TEMPLATES
FULL SIZE**
Visit our blog:
www.todaysquilter.com
today!

Thank you for making this project from *Today's Quilter*. The copyright for these templates belongs to the designer of the project. They work hard to create projects for you to enjoy, so please don't re-sell or distribute without permission. Please do not make any part of the templates or instructions available to others through your website or a third party website, or copy it multiple times without permission. Copyright law protects creative work and unauthorised copying is illegal. We appreciate your help.



RED & WHITE MEDALLION

APPLIQUÉ AND FOUNDATION PIECING TEMPLATES

PLEASE NOTE:

Pentagon and appliqué templates
Do not include seam allowances

DOWNLOAD
THESE TEMPLATES
FULL SIZE

Visit our blog:
www.todaysquilter.com
today!

FOUNDATION PIECING TEMPLATE

ENLARGE BY 200%

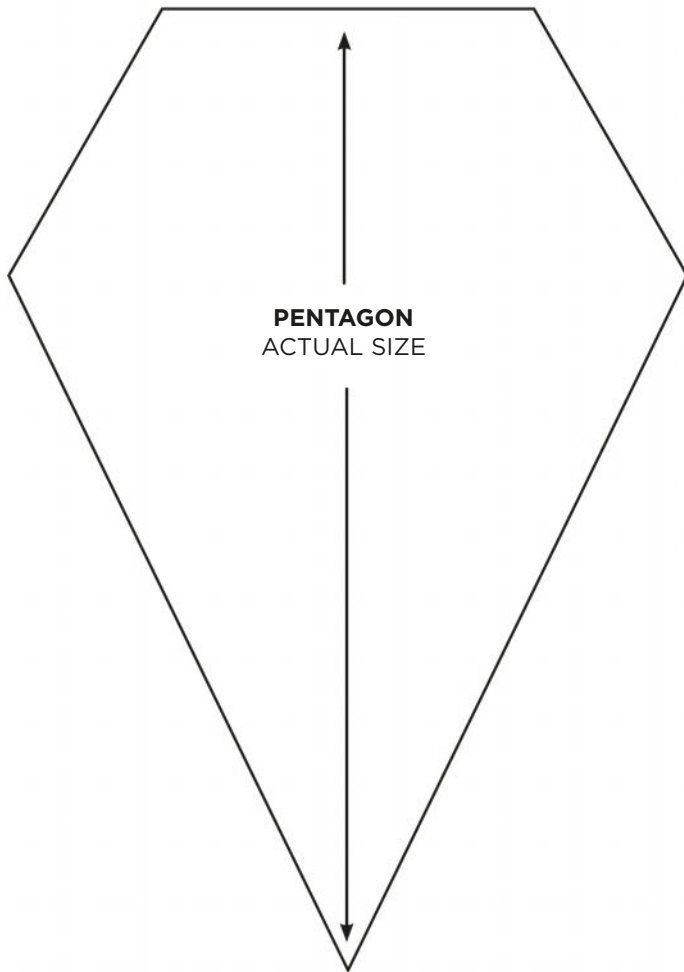
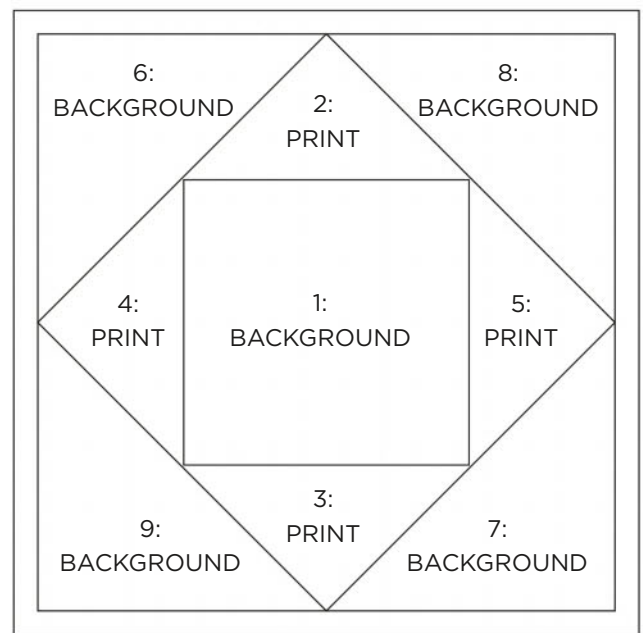

FLOWER CENTRE
ACTUAL SIZE

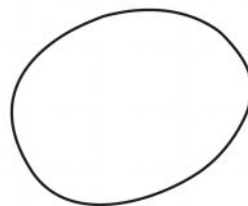

APPLIQUÉ FLOWER
ACTUAL SIZE

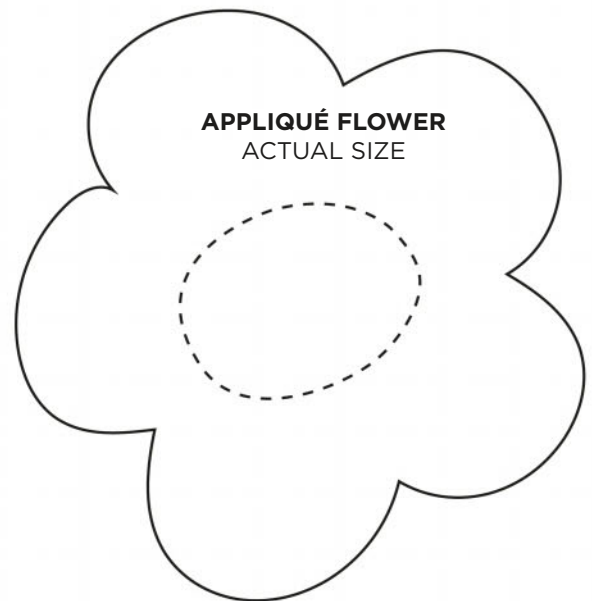

Thank you for making this project from *Today's Quilter*. The copyright for these templates belongs to the designer of the project. They work hard to create projects for you to enjoy, so please don't re-sell or distribute without permission. Please do not make any part of the templates or instructions available to others through your website or a third party website, or copy it multiple times without permission. Copyright law protects creative work and unauthorised copying is illegal. We appreciate your help.

THE ROSE STAR

KITE TEMPLATE

ACTUAL SIZE

Includes seam allowances

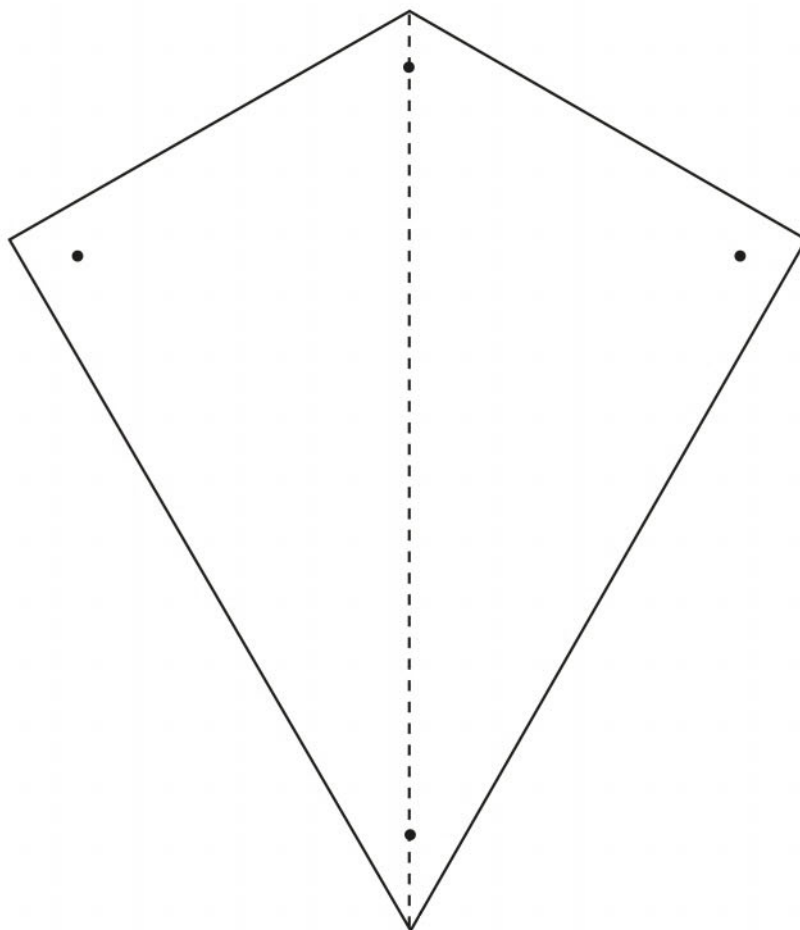

Thank you for making this project from *Today's Quilter*. The copyright for these templates belongs to the designer of the project. They work hard to create projects for you to enjoy, so please don't re-sell or distribute without permission. Please do not make any part of the templates or instructions available to others through your website or a third party website, or copy it multiple times without permission. Copyright law protects creative work and unauthorised copying is illegal. We appreciate your help.



BLOCK OF THE MONTH

LARGE SNOWFLAKE TEMPLATE

— —
ACTUAL SIZE

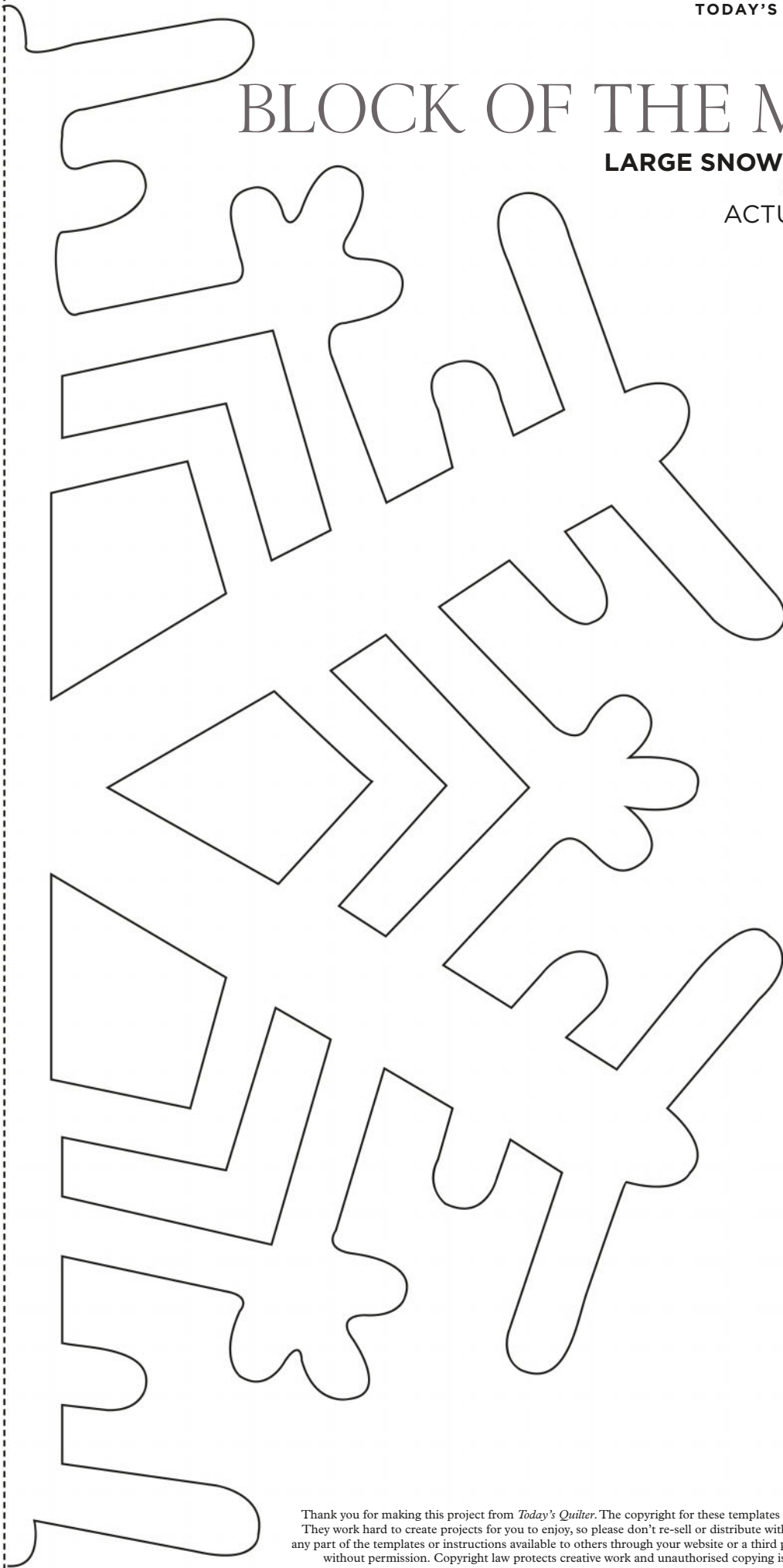

Thank you for making this project from *Today's Quilter*. The copyright for these templates belongs to the designer of the project. They work hard to create projects for you to enjoy, so please don't re-sell or distribute without permission. Please do not make any part of the templates or instructions available to others through your website or a third party website, or copy it multiple times without permission. Copyright law protects creative work and unauthorised copying is illegal. We appreciate your help.

BLOCK OF THE MONTH

SMALL SNOWFLAKE TEMPLATES

ENLARGE 200%

**DOWNLOAD
THESE TEMPLATES
FULL SIZE**
*Visit our blog:
www.todaysquilter.com
today!*

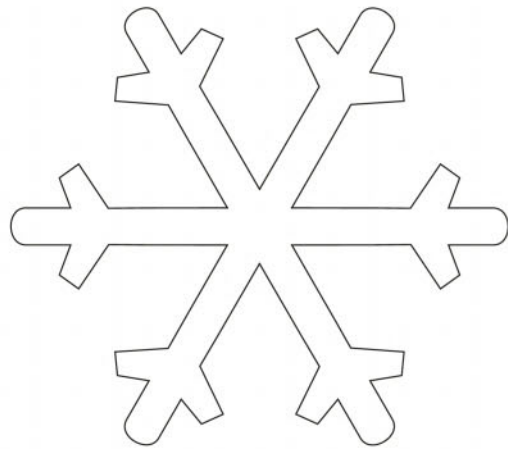
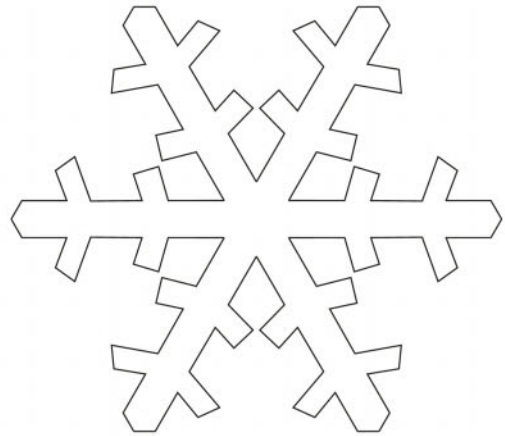
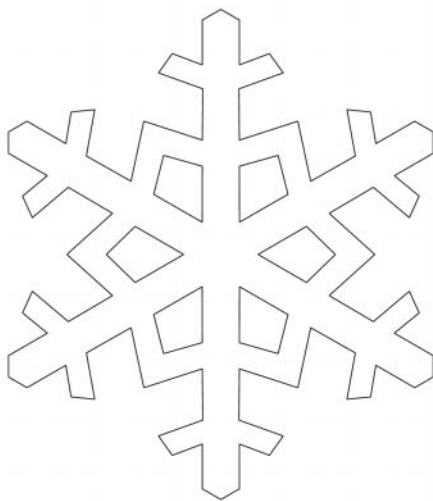
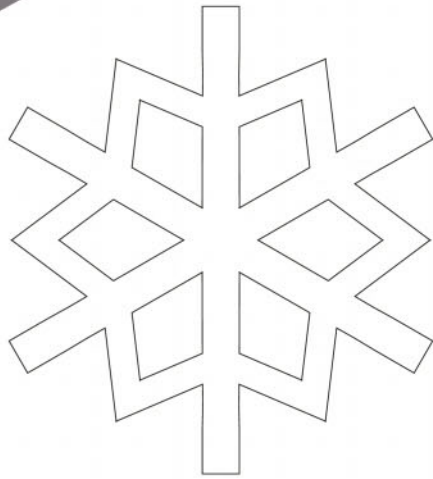

Thank you for making this project from *Today's Quilter*. The copyright for these templates belongs to the designer of the project. They work hard to create projects for you to enjoy, so please don't re-sell or distribute without permission. Please do not make any part of the templates or instructions available to others through your website or a third party website, or copy it multiple times without permission. Copyright law protects creative work and unauthorised copying is illegal. We appreciate your help.



The all-NEW patchwork and quilting experience for Scotland



the SCOTTISH QUILTING show

2-5 March 2017

Hall 4, SECC, Glasgow

A celebration of patchwork and quilting, featuring essential supplies, fabulous galleries, exciting competitions, workshops and talks

Quilting competitions 2017

You are invited to enter your handiwork into one of our exciting quilting competitions, with fabulous prizes to be won!

CATEGORIES:

- A. TRADITIONAL QUILTS
- B. CONTEMPORARY ART QUILTS
- C. JOURNAL QUILTS
- D. GROUP QUILTS
(ONE QUILT MADE BY TWO OR MORE MAKERS)
- E. THEMED QUILTS – ELEMENTS

To download the competition entry form and rules visit: www.thequiltingshow.co.uk
Or phone: +44 (0) 1425 272711 for a hard copy by post.



SEARCH PRESS
specialist art and craft book publishers

storage
CRAFTS

JANOME

Siesta

Quilt: Hanne Asbey – Silver Winner, Carnival 2016. Details correct at time of going to press, but may change due to unforeseen circumstances.

TODAY'S QUILTER Reader Offer

Scottish Crafting Escape

What's included?

- Return transfers from Edinburgh to Stirling
- One day entrance to the Edinburgh Knitting and Stitching Show
- Workshop with Gillian Cooper at your hotel in Stirling
- Workshop with Pat Archibald at her studio in Edinburgh
- 5 nights' accommodation at the Stirling Highland Hotel on a half-board basis
- Tour of Edinburgh
- Excursion to the Fife Folk Museum and the Wemyss School of Needlework
- Coaching as described in the itinerary
- The services of an Arena Tour Manager
- Baggage handling at the hotel



Saturday 29 April - Thursday 04 May 2017
6 days from £699 per person

Visit www.arenatravel.com/scotland or
call 01473 660800 for more information

Stichtopia



ARENA
TRAVEL
Passionate about your passions

*Find full payment details and options on the website. Please ensure you check this website for the latest details on all holidays.

FOR YOUR STASH

must-have fabrics and supplies



THE QUILT LADY

Come and learn to quilt in Cornwall. Small, relaxed ½, 1, 2 and 5 day classes for all abilities. Equipment and materials available.
sara@thequiltlady.co.uk



HAZEL'S FABRIC CRAFT

West Calder. Patchwork & Quilting supplies and workshops. Open Fri & Sat 9.30am–4.30pm, Sun 10am–2pm.
hazelsfabriccraft.co.uk



RICKY TIMS

Long awaited return visit to Patchwork Parade, 15th July 2017. (venue Middleton Arena). Tickets on sale 3rd Jan 2017 from Patchwork Parade.
0161 633 5900 Phil Langford



THE QUILT SANCTUARY

Professional Long Arm Quilting Service, including a selection of fabrics and wadding. Gwynedd, Wales.
01341 250809 / 07402 919194
thequiltsanctuary.co.uk



CREATIVE CRAFTS

Creative Crafts is an independent arts & crafts shop bursting to the seams with everything you need for your hobby.
01962 856266



HOMETOWN

Keep warm this winter by quilting. Discover fabrics and wadding at 62 High Street, Rochester, Kent.
01634 838880
hometownrochester.co.uk



CHALK HILL BLUE FABRICS

Supplier of patchwork fabrics, threads, waddings and notions. See you on Facebook!
01903 230008
FB/ Chalk Hill Blue Fabrics



FABRIC TREASURE

Quality cotton fabrics for patchwork, accessories & clothing. MODA pre-cuts, Frivols, jelly rolls & layer cakes.
fabrictreasure.co.uk



TEMPTATIONS

Everything you need for Patchwork and Quilting. Hundreds of quality cotton fabrics, wadding, haberdashery, Brother Sewing Machines.
temptationsbentham.co.uk



TYLER'S PATCH

Classes in Lacemaking and Patchwork Quilting, group sessions and events, plus all your quilting fabric and equipment needs!
tylerspatch.co.uk



28 Queens Road

Craig-y-Don
Llandudno
Conwy, North Wales
LL30 1AZ
thequiltingbeecyd@gmail.com
01492 878599



HORNCASTLE SEWING CENTRE

A friendly welcome for fabric crafters. Fabric, haberdashery, wadding and notions.
01507 524596
thesewstore.co.uk

TODAY'S
QUILTER
Create beautiful quilts for your home

- 56% of readers visit Today's Quilter's website after reading our magazine
- 85% of readers find advertising in Today's Quilter Useful
- Today's Quilter currently sells 419% more than its closest competitor!



Sticky Fingers

STICKY FINGERS

Wide range of 100% cotton patchwork fabrics, waddings, threads and notions, Janome sewing machine accessories.
stickyfingerscrafts.co.uk



CRAFT HIVE

Fabrics, Threads, Wool & Haberdashery, Workshops and Craft Groups.
16c Front St. West, Bedlington, Northumberland NE22 5UB
crafthive.co.uk 01670 821758



SEW & SO'S

Everything for the patchwork quilter, over 6,000 bolts in stock plus notions. 14 Upper Olland Street, Bungay, NR35 1BG
sewsos.co.uk 01986 896147



PEMBERTONS

Everything for the Quilter, fantastic selection of machines, cabinets, habby, fabrics & notions. Friars Street, Stirling.
psmc.co.uk 01786 462993



THE CORNER PATCH

A little corner of patchwork heaven. Fabric, wadding, threads and haberdashery. Workshops for all ages and abilities.
thecornerpatch.co.uk



FROM RAGS TO STITCHES

Utterly delightful fabric emporium. Shop online, sewing classes. Tickhill, Doncaster 01302 750973.
fromragstostitches.co.uk



RUTLAND SEWING

Pfaff dealer, patchwork and dress fabrics, haberdashery, classes, books. Free parking. Closed Mondays.
01572 756468



COAST AND COUNTRY CRAFTS & QUILTS

Cornwall's specialist Patchwork Shop stocking beautiful books, linens, magazines, patterns & fabrics.
coastandcountrycrafts.co.uk

Useful guide to quilting goodies!
DIRECTORY

Find the fabrics, accessories and more that you want from this month's issue.

SHOPPING

ACCESSORIES

Oakshott bag
www.oakshottfabrics.com
0145 237 1571

Trimits ruler
groves@stockistenquiries.co.uk

Westalee Ruler
www.cottonpatch.co.uk
0121 778 5327

Supersize 5-in-1 sliding gauge
clover@stockistenquiries.co.uk
0145 388 3581

Aurifil
www.aurifil.com

Sew Easy Mini Templates
groves@stockistenquiries.co.uk

BOOKS

Search Press
www.searchpress.com
0189 251 0850

Abrams & Chronicle Books
www.abramsandchronicle.co.uk
0190 382 8501

FABRIC COLLECTIONS

The Garden of Dreams
www.libertylondon.com
0207 734 1234

Guess How Much I Love You III
www.egsuk.com
www.clothworks.com
0116 271 0033

Hotel Frederiksted
www.freepiritfabrics.com



The Jane Austen's House Museum is located in Winchester Road, Chawton, Hampshire, GU34 1SD
Admission: £8.00 adults. For more info, visit www.jane-austens-house-museum.org.uk



To mark the bicentenary of Jane Austen's death, the Jane Austen's House Museum is creating a story quilt. To find out more about how you can take part, turn to *Fresh Picks*, page 17.

“The quilt was made by the English paper piecing method – how we wish the papers had been left in – they might have been scraps of letters, or even discarded writings by Jane!”

JANE AUSTEN'S QUILT

In addition to her great talent as a writer, Jane Austen was an accomplished seamstress.

In May 1811, Jane wrote to her sister Cassandra: “Have you remembered to collect pieces for the Patchwork? – we are now at a stand still.” As quilters, we can certainly relate to this point in proceedings. Luckily for us, many of Jane's pieces of fine needlework survive and can be seen on display at Jane Austen's House Museum

The Museum is the place where Jane wrote or revised all her published novels and is visited by over 40,000 people each year. One of the most popular exhibits is the quilt made by Jane, her sister Cassandra and their mother. In fact, it is not a quilt but a coverlet, as there is no layer of wadding, simply a patchwork top with a cotton backing. It is a frame quilt with a large central motif in chintz, cut as a diamond. This is surrounded by a central panel of 249 smaller diamonds interconnected by spotted sashing. The outer edge, 11 inches deep, is composed of over 2,500 tiny diamonds.

Sue Dell, who is Collections volunteer at

the Museum, has a keen interest in the Jane Austen Quilt, and has spent many hours in its company. “There are many remarkable things about this quilt, aside from the fact that it was stitched by one of the world's favourite authors. The central panel of diamonds shows fourfold symmetry in their placement and the tiny diamonds in the outer edge are also placed symmetrically with top and bottom, and left and right sides matching. There is also extensive use of fussy-cutting in the diamonds. This was a very carefully planned quilt.

“The diamonds are 70° and 110° angles, which is unusual, and the sashing joining the central diamonds is composed of short pieces, rather than continuous lengths – perhaps fabric left from a previous project? We have not found another quilt like this anywhere, it is a truly unique piece (although there are rumours of other quilts made by the Austen ladies, and this was clearly not the first quilt they had made in terms of the quality of the design).”

Do you have a quilt with a tale to tell? Let us know, and you could be featured on the Back Story page! Email todaysquilter@immediate.co.uk or write to Today's Quilter, Tower House, Fairfax St, Bristol, BS1 3BN

TODAY'S QUILTER

Create beautiful quilts for your home

NEXT
ISSUE
On Sale
2nd February

GARDENER'S WORLD
Glenna Hailey has sewn
these beautiful tulips
for you to pick!



CHOCOLATE BOX Carolyn
Forster's quilt is truly
scrumptious



THE KAFFE COLLECTIVE
Go behind the scenes
with this unique group
of designers!

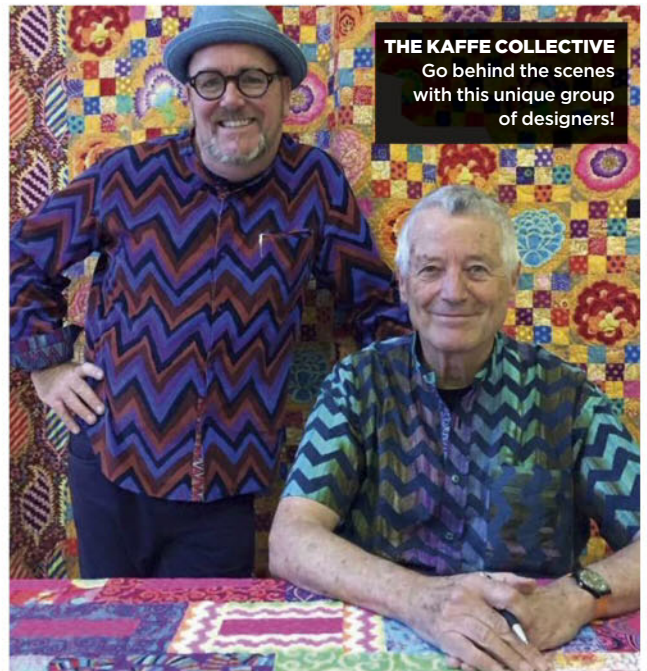

Embrace colour for dynamic results!

Gail Lawther makes her TQ debut with enchanting silhouetted owls • Meet award-winning long-arm quilter **Sandy Chandler** • Sew in shades of chocolate with **Carolyn Forster** • Discover Danish style with our **Hygge** cushion!

FREE! Supplement bursting with beautiful blocks to mix and match

Issue 19 on sale 2nd February



Innov-is F420

The Innov-is F420 is packed with a huge range of features including 140 stitches, lettering, lock stitch button, automatic thread cutter, and Square Feed Drive System for strong, smooth, even sewing on all types of fabric.



Innov-is 55FE

The feature-packed Innov-is 55 Fashion Edition will shape your fashion dreams into reality. 81 stitches including 10 one step button hole styles plus lettering together with the included 12 accessory feet make this an excellent all round machine.



Innov-is 27SE

The Innov-is 27SE offers fantastic versatility for both the beginner and experienced sewer. With fingertip controls, 50 stitches including 5 one step button hole styles and a protective hard case; it's ideal for all kinds of sewing.

Create your own style



TODAY'S
QUILTER
Create beautiful quilts for your home

NEW CATHEDRAL WINDOW

The updated machine technique by Lynne Edwards MBE

— An exclusive supplement —



INCLUDES

5

PROJECTS

USING THE NEW
TECHNIQUE

A PASSION ADVANCED!

Master Lynne Edwards' new
machine method, step by step

Achieve faster *and* stronger results

Create five beautiful new projects
designed by Lynne





WELCOME

Cathedral Window quilts are some of the most stunning fabric creations I've had the pleasure of seeing. Their intricate three-dimensional quality takes my breath away (as did the weight when I lifted one!). Although it's rarely a good idea to mess with a classic, there are some exceptions to the rule. Lynne Edwards was already queen of the Cathedral Window, so trust her to come up with a technique that allows us to create these beautiful blocks with results that are not only faster, but stronger, than the original. We adore Lynne's attitude to quilting: sharing knowledge and fun are crucial. It's this outlook that allowed her to develop this new Cathedral Window technique. For those of you who enjoyed the original technique, do try this new method to discover just why it's so exciting. If you've never attempted Cathedral Window quilts before, then this is the perfect time to give it a go.



Jenny

Jenny Fox-Proverbs

Senior Editor

TODAY'S
QUILTER
Create beautiful quilts for your home

Senior Editor Jenny Fox-Proverbs Art Editor Kit Cheung Deputy Editor Fiona Smith
Technical Editor Laura Pritchard
Advertising Manager Penny Stokes Editorial Production Coordinator Lizzie Ayre

Printed in the UK. Presented with Issue 18 of *Today's Quilter* magazine.
© Immediate Media Co. Not to be sold separately.

To subscribe to *Today's Quilter* call 01604 828744 or go to www.buysubscriptions.com

Todaysquilter Todaysquilter Todaysquilter Todaysquilter www.todaysquilter.com





Discover
NEW WAYS
WITH CATHEDRAL
WINDOW

*Recreate this traditional patchwork
technique using modern machine
methods to construct and join the blocks.*



Lynne Edwards is the acknowledged expert in Cathedral Window and a great enthusiast for it. Her passion for the technique has led to the development of this new method of machine-stitching and joining together of the classic folded squares that are the basis of the design. “I want quilters to love Cathedral Window, so I needed to make it as easy as possible for them to achieve without compromising the technique in any way. This is how I make all my blocks now, limiting the handwork to the exciting part, which is the stitching of the curves that make Cathedral Window so distinctive.”

Using this method, any Cathedral Window design can be achieved quicker and with more strength in the seams. The traditional unbacked quilts look so much better on the reverse side too, which is an added bonus. Blocks can be combined with regular patchwork as never before, giving a totally new look to this much-loved patchwork technique.

Follow the step-by-step instructions in the Technique section to master the stitching of the folded squares, with all the tips for getting it right at every stage. The majority of the projects use small amounts of Cathedral Window, often combined with borders and backgrounds of regular patchwork, which display the technique at its best in these stunning designs.

“Within the pages of this supplement, I’ll tackle how to make a four-square block, which covers all the hands-on technique instructions with all the tips to get it just right –

this really is a new way to construct the block, so everything that’s needed to get started and get it right is included.

“The instructions give two choices of design, and these make the first project, a pair of cushions. I also give you the option of a second project, a little carrying case made from the essential four-square block. Then, taking the skills and knowledge you’ve learnt, I show you a repeat four-square unit that can be added to, block by block, to make any size at all – I call it the Everlasting Cathedral Window pattern – a traditional unbacked design made in this new easier way. This project is Heather Jackson’s 25-unit quilt, plus a collection of individual four-square units that Wendy Jobber is making just for pleasure, so not yet assembled into any fixed design. For fun, I show you how to make a Christmas table runner – a great project to make for the festive season using this technique. We move on next to a wall hanging based on nine folded squares, again mounted on a background square with a new take on the outer edges of the folded block, which are stitched back and curved on to the frame. This design could just as easily be made into a cushion if preferred. Finally, a larger more complex wallhanging made by combining four of the nine-square units that made up the previous project. Again, the Cathedral Window design is mounted on a background, this time on-point, plus additional surface quilting is used as an integral part of the design – a nice combination of regular patchwork with Cathedral Window.”

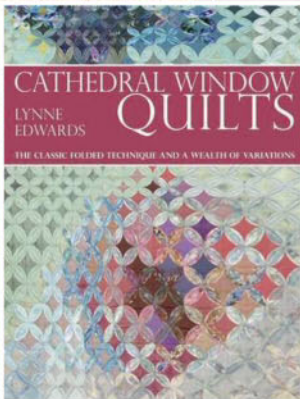
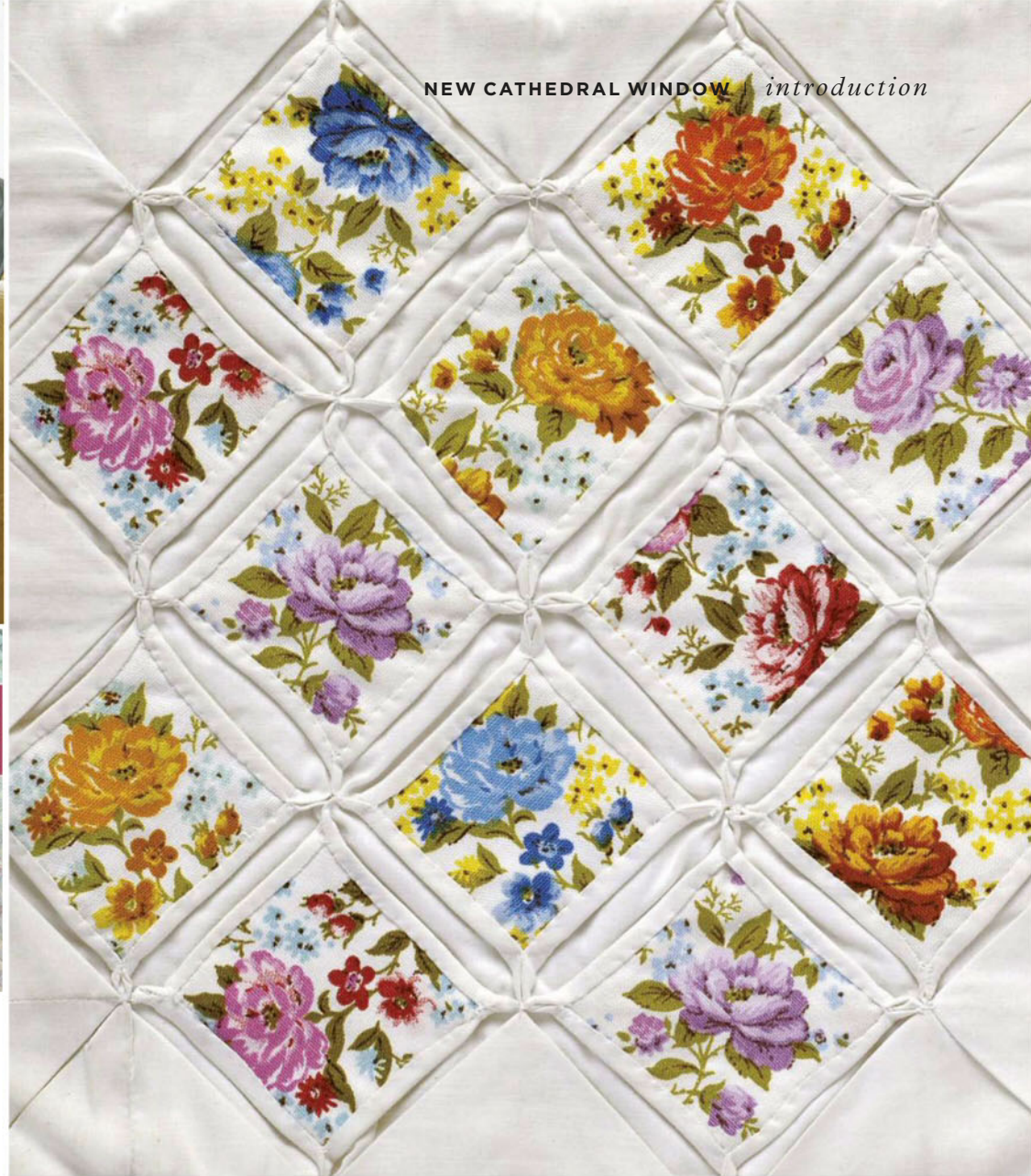

Left, Lynne Edwards MBE; Top, Dawning Rose Cathedral Window Quilt; Above, Cathedral Window Quilts; Right, A piece of traditional Cathedral window from the US, made by Susan Harvey from Jersey and given to Lynne

CONTENTS

04 Introduction

Lynne talks you through the supplement, and what is included

08 Basic Technique

Learn Lynne's New Cathedral Window technique

19 Project: Cushion

Use the knowledge you've gained to create a pretty cushion

20 Project: Carrying Cases

Still using the four-square block make a useful carrying case for glasses, rotary cutters ect

24 Project: Quilt

You'll love this Everlasting Cathedral Window design, just keep adding four-square units till you're happy!

30 Project: Tablerunner

Spread some festive fun with this delightful design

36 Project: Wall Hanging

Decorate any room with this nine-square hanging

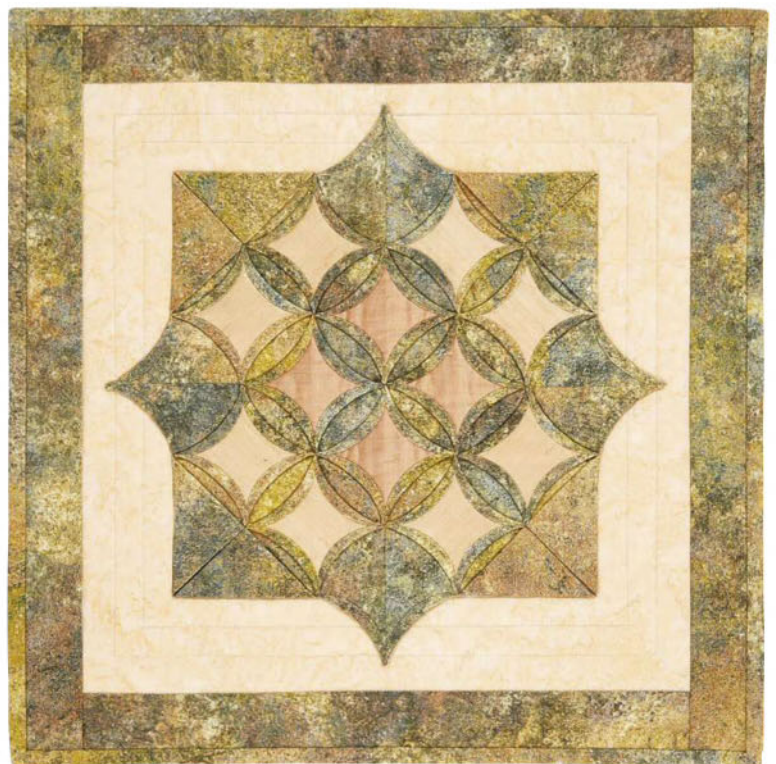

The versatile four-square Cathedral Window block can be framed in different ways, as shown on these pretty cushions

MAKING A FOUR-SQUARE BLOCK

THE NEW TECHNIQUE

The essence of this new approach is to keep the design simple and striking, often framing it by mounting it on a piece of background fabric. Let's get started by mastering the technique in this classic block made from four folded squares.





MAKING A FOUR-SQUARE BLOCK
TECHNIQUE



"Less is more! A simple design of four classic Cathedral Window blocks is framed and transformed into this elegant cushion."

You will need

- Fabric for the folded squares – one (1) fat quarter
- Fabric for the four (4) small squares that make the windows – a piece about 6in square. This will make all four windows
- Background fabric to frame the Cathedral Window block – one (1) square at least 13in square

Making a Four-Square Block

1 From the chosen fabric cut four (4) 8in squares.

2 Fold each cut square in half with right sides facing. Pin and machine-stitch an exact 1/4in seam at either end (Fig 1). I stitch all four squares at once, stringing them through the machine in a chain, one after the other. Leave about 1in of thread between each stitched square. Cut the linking threads after stitching to separate the folded squares. Leave about 1/2in of machine threads hanging at the folded end of each seam. These threads are a great help

when you come to finger-press the seams open later.

3 Trim the two folded corners diagonally to within 1/8in of the stitching to reduce the bulk of the fabric (Fig 2).

4 Pull the open edges of the folded square apart and refold with the seamlines matching exactly. Finger-press the seams open as you match them, taking care not to pull any of the stitches undone as you do so. Pin diagonally across the seam junction to keep the layers of fabric in place (Fig 3A). Now match the raw edges exactly and add more pins to one side only (Fig 3B).

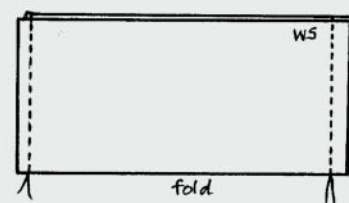

Fig 1



Fig 2

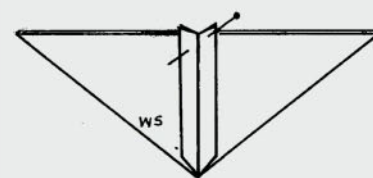

Fig 3A

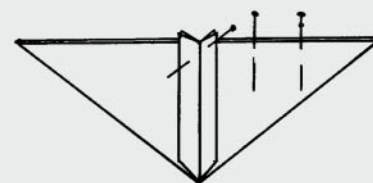

Fig 3B



5 Starting at a point about $\frac{1}{2}$ in to the left of the centre seam, stitch a $\frac{1}{4}$ in seam across the centre along the pinned section to the folded end of the seam (Fig 4). Leave the machine threads about $\frac{1}{2}$ in long at the folded end.

6 Turn the fabric over and pin the remaining section of the seam, matching the raw edges as before. Starting at a point about 2in from the end of the previous stitched seam, stitch a $\frac{1}{4}$ in seam to the other folded end of the fabric (Fig 5).

7 Trim the two folded corners at either end of these seams as shown in Fig 2.

8 Place the folded square flat on a surface and finger-press the seams open, including the unstitched section (Fig 6). Pull on the threads at the corners of the square to help you press them open as firmly as possible. If you have a tiny quilter's iron, or a wooden pressing tool usually used in foundation patchwork, these might help. I just use my thumbnail to do the job!

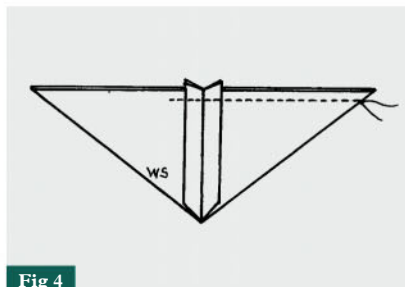

Fig 4

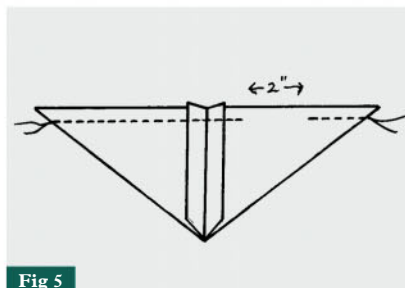

Fig 5

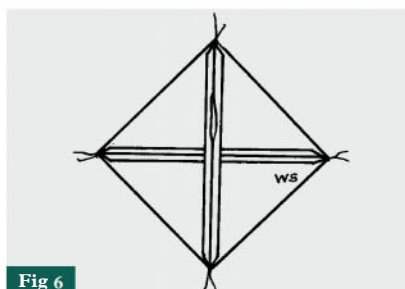

Fig 6

**TECHNICAL TIP**

At this stage the folded square of fabric should lie flat on the table. If it seems twisted or undulating at all, it's a warning sign that something is wrong. Possibly the original square was not cut exactly 8in on all sides, or perhaps the seams were not all $\frac{1}{4}$ in wide. Now is the time to get this sorted, before the next stage in the process.





9 Turn each folded square right side out through the centre opening. Use a large pin (i.e. one that isn't too sharp and doesn't do too much damage) to ease out each corner. Hold the opened seam allowances firmly between thumb and forefinger as you turn so that they stay open. The aim is to finish up with the corners of the square as flat and pointed as possible (Fig 7).

10 Using a steam iron, take each square of fabric and press firmly, pulling the corners out as much as possible as you do so. Tuck under the unstitched folded edges at the gap so they butt together edge to edge exactly. These edges do not have to be hand-stitched together – they will be held in position by a line of machine stitching across them when the blocks are joined.

11 For this new way of joining the folded squares, you need to find the centre of the sides of each square. The easiest way to do this is to simply fold each pressed square in half and press the folded corner at either end with the iron – just press about $\frac{1}{2}$ in at the corner, no more. Unfold the

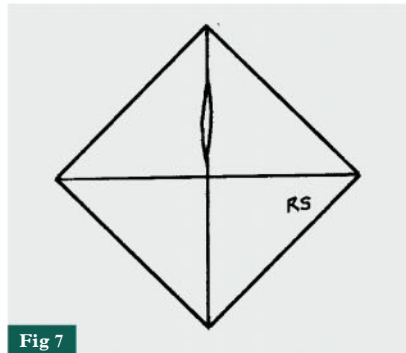

Fig 7

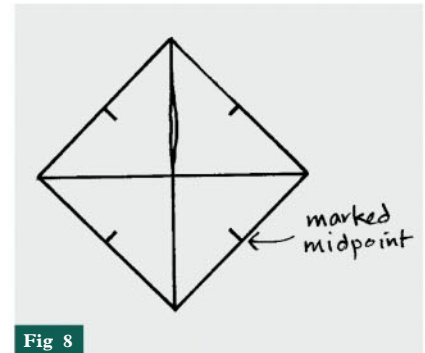

Fig 8

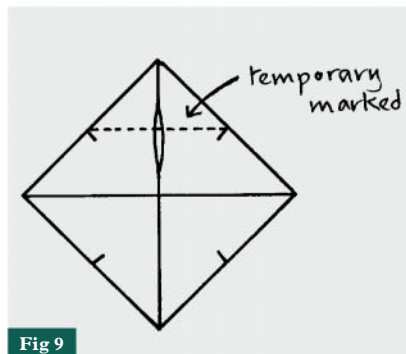

Fig 9

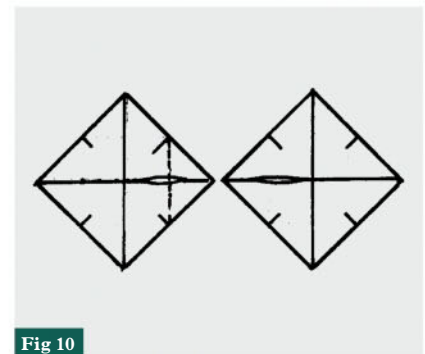

Fig 10

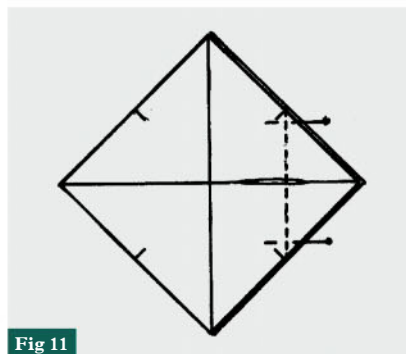

Fig 11

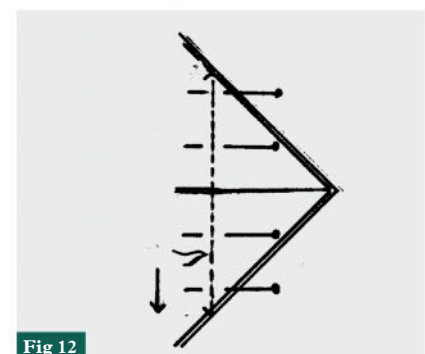

Fig 12

square and fold it in the opposite direction. Press the corners as before to mark all four mid-points of each side of the folded square (Fig 8). If the pressed marks are not too clear, highlight them with a temporary fabric marker, as it's important to get these accurately marked.

Joining the folded squares

The stitching lines for joining the squares need to be marked with a temporary marking pencil. Only the top layer needs to be marked as a guide for the stitching.

12 Join the marked mid-points across the unstitched gap of one folded square with a fine temporary marking pencil, keeping the marking as light as possible, especially at the

ends, where the marks may show slightly when the edges are rolled back and stitched later (Fig 9). Repeat this with a second folded square.

13 Arrange one marked fabric square with an unmarked square, each with the unstitched sections positioned as in Fig 10. These will be stitched together along the marked line. Place the two squares together with the unmarked sides facing and the two unstitched gaps positioned on top of each other. Match exactly the marked mid-line points at either end of the stitching line on the top square with the marked mid-points on the underneath square and pin together (Fig 11). Pin through all layers in two more places along the stitching line, making sure that the edges of the



unstitched sections on each square are closely butted together.

14 Use a thread on the machine that matches as closely as possible the fabric of the folded squares. If the two squares to be joined are different colours, use a matching thread for the top square of the layer and a different colour thread in the bobbin to match the bottom square of fabric. Fiddly, I know, but necessary if the stitching is to remain unseen in the final design. I also change the foot on my sewing machine from the $\frac{1}{4}$ in foot to an open-fronted appliqué foot, so that I can see the marked line as I stitch along it. It is the stitching at either end of the marked lines that is the most visible in the finished design, so it is best not to start and finish stitching at these places. I

begin about $\frac{1}{2}$ in from the bottom end of the marked line and stitch towards the outer edge (**Fig 12**). At the end of the marked line, absolutely on the edge of the fold, I sink the needle into the fabric, lift the pressure foot of the machine and turn the fabric round through 180-degrees. Then I stitch along the marked line until I get to the other end. Again, I stop right on the folded edge, lift the foot, turn the work through 180-degrees and stitch back along the line for about $\frac{1}{2}$ in before finishing and cutting the threads. Trim all the thread ends close to the stitches so there is no chance of them showing at all.

15 Repeat steps 12-14 to join the other pair of folded squares together in exactly the same arrangement as the first pair.

TQ

TECHNICAL TIP

By stitching across the gap in each fabric square, the edges are held in place and they will be hidden in the layers when the corners of the squares are pulled into the centre and stitched.

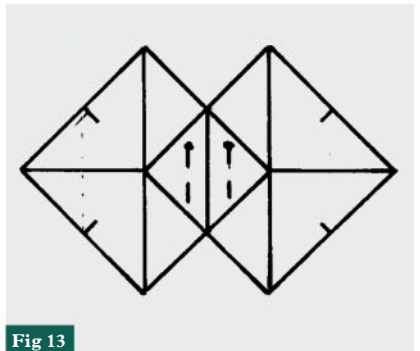

Fig 13

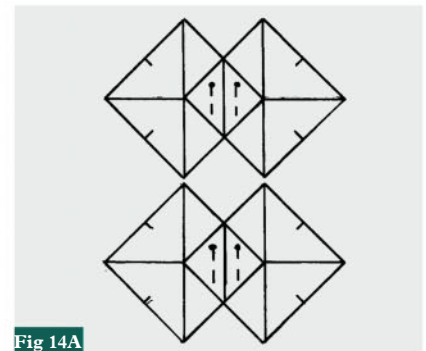

Fig 14A

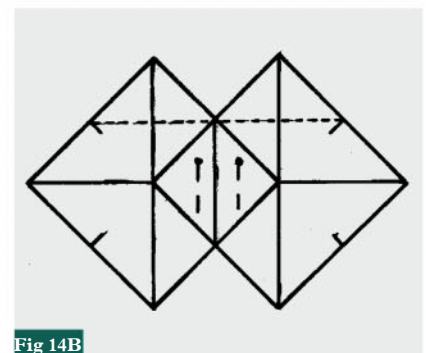

Fig 14B

16 Press the corners of the stitched seams to the centre of each square and pin in place (**Fig 13**).

17 Arrange the two rows of the design as in **Fig 14A**. Mark a stitching line from mid-point to mid-point across one row only (**Fig 14B**).

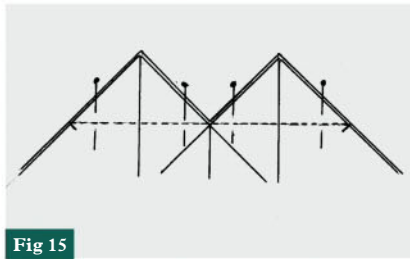

Fig 15

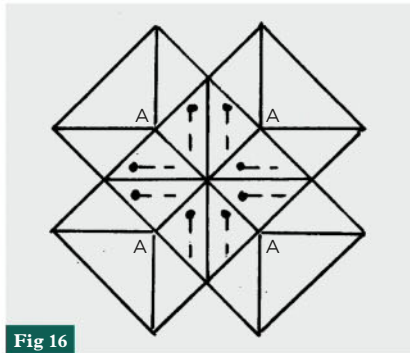

Fig 16

18 Place the two rows together with the unmarked sides facing and the marked stitching lines on the top layer as before. Match the mid-point marks exactly at either end of the marked stitching lines and pin in place, and also at the centre junction, pinning either side as in Fig 15. Add more pins to fix the two layers exactly on top of each other and stitch as before, stitching across the matched mid-point marks from one end of the pinned squares to the other. Start and finish $\frac{1}{2}$ in from the ends as in step 14. The aim is to make a perfect match of the folded edges at either end of the stitching and especially at the centre junction, which will be the central focus of the finished design.

19 Press each of the eight loose corners that are in the middle area of the block to the centre of each folded square, leaving the outer eight corners untouched (Fig 16). Stitch each corner (marked A in Fig 16) by hand onto the exact centre of each square with two small stitches through all the layers. Pull the stitches really firmly and finish off at the back with two tiny stitches through the back layer only. Run the needle into the back layer for about 1in before cutting off the thread to keep the back looking neat.



Tiny pinprick backstitches are Lynne's preferred method for sewing down the rolled edges

Classic Four-Square

If you wish to make a classic four-square block without a background frame, all the loose corners including the outer points must be pressed to the centre of each folded square at this stage and stitched down firmly. To make the four corners fit together snugly, do not stitch each corner down individually. Instead, stitch the two opposite corners down with one small stitch though all the layers at the centre. Arrange the remaining two corners that they fit snugly alongside the first pair, not sitting on top of them. Stitch these two corners down with one stitch through all the layers. The stitches will form a tiny cross at the centre of the folded square. Pull the stitches really firmly and repeat (Fig 17).

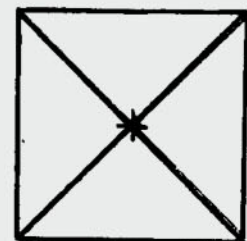

Fig 17

Fussy-cutting

If you want to use a specific area of a piece of fabric in the window such as a flower or a star, you need to cut a square template in the appropriate size from template plastic so that you can position it exactly in the right position on the fabric before drawing round it and cutting it out. Remember that each window is arranged on-point, as in **Fig 18**, so place the template on the fabric to match this.

The outer $\frac{1}{4}$ in of the cut square will be lost when it is covered by the curved edge of the background fabric (**Fig 19**). For most fabrics I just randomly cut squares of the required size with a rotary cutter and ruler as usual.

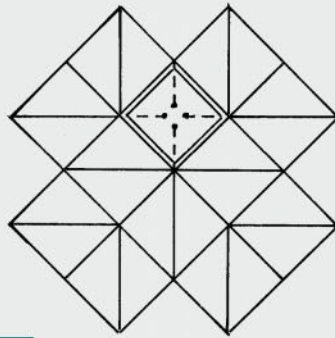

Fig 18

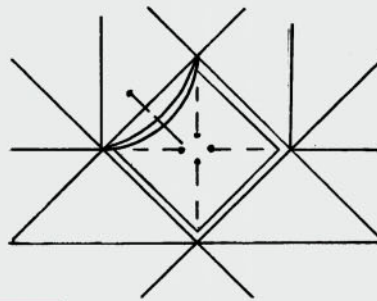

Fig 19

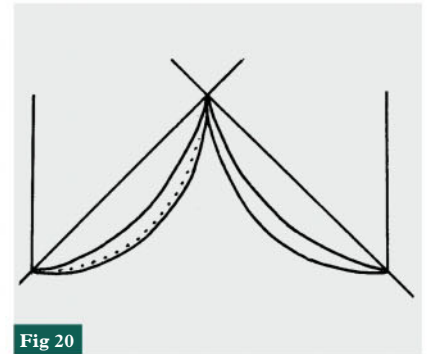

Fig 20

4 Starting at the top centre corner (the corner that has the seam joining the two folded squares underneath it), roll the surrounding border on one side of the window over it, stretching the bias edge to create a curve. Don't be afraid to really stretch that edge so that the curve measures at least $\frac{1}{4}$ in in the centre. Pin the curved edge at the centre as in **Fig 19**.

5 Beginning about $\frac{1}{2}$ in from the corner, stitch the rolled edge down, using either a hemming stitch or tiny spaced backstitches placed close to the folded edge. The backstitch is my preferred method, but you choose whatever stitch gives you the best effect (**Fig 20**). The trick with the backstitch is to place the needle virtually back in the place where the thread is emerging, but just behind it, so that the stitch made looks like a tiny pin-prick without any real length. I do not take my needle through to the back of the work, just into the background fabric below the window. Every few stitches I dig a little deeper to fix the curved edge onto the background layers to make it more secure and less vulnerable to wear and tear.

6 Since all raw edges of the window fabric need to be covered, stop stitching about $\frac{3}{8}$ in from the corner and bring both bias edges over the window. Some of the corners can be quite bulky and resist being pulled over the window fabric. I use the side of a fine pair of scissors or the edge of a hera (a Japanese marking tool) or even the blunt edge of an old butter knife to press a central groove in the layers to encourage the

Adding the windows

I do all the stitching of the windows by hand, not just because I enjoy it hugely, but also because I find it the best way to make sure that the raw edges of the squares of window fabric are securely covered by the rolled edges of the folded squares. If, however, you are an absolute ace at machine work and can manage this task on your trusty sewing machine, then please go ahead and do it – nothing is forbidden in patchwork, despite what the quilt police say...

1 The windows that are added to the folded squares for this size are made from $2\frac{3}{8}$ in squares. Cut four (4) of these squares from the chosen window fabric.

2 The four background folded squares when joined together create four small squares on-point at the centre as in **Fig 16**. This is where the four squares of window fabric are positioned. Start by pinning one window in place, pinning each corner as in **Fig 18**.

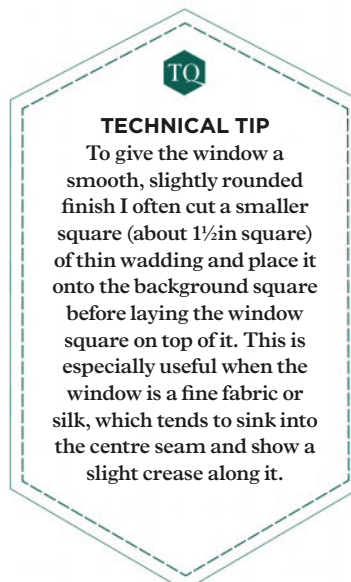

TECHNICAL TIP

To give the window a smooth, slightly rounded finish I often cut a smaller square (about $1\frac{1}{8}$ in square) of thin wadding and place it onto the background square before laying the window square on top of it. This is especially useful when the window is a fine fabric or silk, which tends to sink into the centre seam and show a slight crease along it.

3 Trim the window fabric down if necessary until about $\frac{1}{8}$ in of the background fabric shows on all sides. If your fabric is bulky you may like to cut a slight curve along each side to reduce the bulk of fabric when the background fabric is rolled over it. If so, do not trim away at the corners of the window fabric – leave them at the original $\frac{1}{8}$ in distance from the background fabric.

rolled edges to meet in a balanced way when pulled over the window. Don't be gentle with this – place the piece of work flat on a table and really push very hard with the side of the scissors or hera to flatten the fibres in the layers of fabric along the centre groove.

7 When you are happy with the look of the rolled edges at the corner, stitch a bar stitch a good $\frac{1}{4}$ in from the corner (**Fig 21**). Stitch straight across both rolled edges from side to side, not through any of the underlying layers. Often quilters stitch too near the corner before making the bar stitch, which risks the window fabric fraying out. A $\frac{1}{4}$ in is the safest distance from the corner to keep the window fabric in place and protect its raw edges. Pull the stitch firmly and repeat it, this time bringing the needle up into the next rolled edge ready to begin stitching this side of the window in place.

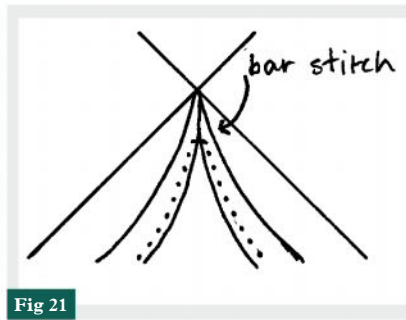

Fig 21

8 Stitch all four sides of the rolled edges around the window, treating each corner in the way described above. When the final corner is reached, the original stitching began $\frac{1}{2}$ in from the corner, so there is room to make the final double bar stitch $\frac{1}{4}$ in from the corner to match the others.

9 To finish, bring the needle to the back of the work in the joining seam between the two blocks. Make a couple of tiny stitches into the back layer of fabric only and run the

needle into this layer for about 1in before cutting off the thread. Turn the work over to the right side. I defy you not to pat the window fondly and give a little sigh of contentment at the way the window fabric is framed so nicely by the curved edges. I shall now say what most quilters say when anyone looks at or admires their work – “Don't look too closely...”

Of course it won't be perfect – a first attempt never is, and of course it takes so long at this stage to do just one window. Remember that anything learnt for the first time takes about four times as long as when you are comfortable with the technique. You may see poor corners and flawed stitches, but no one else will. There are four window squares to be stitched in this way, so by the time you have completed the last one, you will have gained confidence and the skill to explore the technique in so many different projects.

Design ideas for the four-square block



The cushion (left) made by Marjory Dench, was framed following the Style A frame instructions, with a ruffle trim added in a print to match the windows. To make your own cushions from your block, follow the



instructions on page 19. The orange quilt (right) made by Lois Roberts, is made using the Style B frame, with blocks attached using the quilt-as-you-go method.



Framing the design

Cathedral Window is a unique technique that makes a piece of patchwork that needs no border, no wadding (batting) and no backing fabric. Traditionally, the folded squares are joined one by one by whip stitching the folded edges together by hand and then adding the windows until the piece is complete. Using this new way of joining the blocks by machine, it is possible to stitch the folded squares to a larger piece of background fabric that will support the design and frame it. The framing fabric is a single layer, so the outer edges can be treated as a regular piece of patchwork and combined with other fabrics to make a larger design with the Cathedral Window appliquéd to it. This enhances the intricate Cathedral Window blocks, providing space around them and making them the focus of the design.

Framing the block – Style A

1 To make the Style A as shown in **Fig 22**, take the Cathedral Window block and mark the stitching lines with a temporary fabric marker from mid-point to mid-point (**Fig 23**) in the usual way.

2 Place the block centrally on the right side of a 13in square of framing fabric and pin it in place along the marked lines as in **Fig 24**.

3 Stitch continuously along the marked lines, starting halfway along on one side and stitching all the way round, finishing by overlapping the starting stitches by about $\frac{1}{2}$ in to secure the seam. Trim the threads close to the work.

4 Press the eight outer corners in to the centres of the folded squares and pin in place (**Fig 25**). Stitch each corner onto the block, stitching firmly through all the layers (see step 19 on page 14).

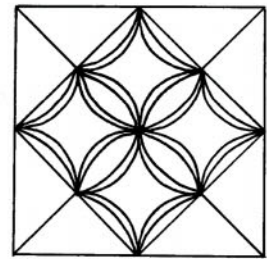

Fig 22 Style A

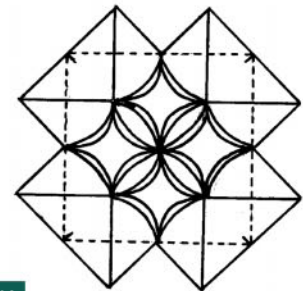

Fig 23

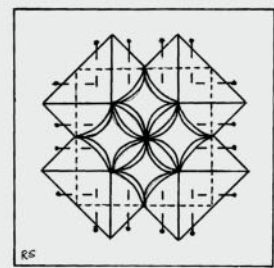

Fig 24

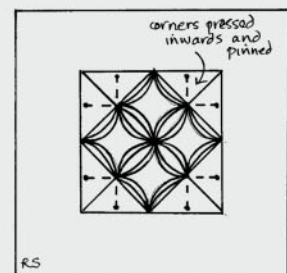

Fig 25



TECHNICAL TIP

To centre the block accurately on the square of background fabric, fold the background square in half vertically. Then unfold it and refold it in half horizontally. Use these fold lines to help position the block centrally on the background.



TECHNICAL TIP

I like to leave the Cathedral Window block supported by the square of framing fabric, as it gives it stability, but if this seems a shocking waste of your precious fabric, before stitching the eight outer corners into place at the centre, remove the pins and turn the work to the back. Pull the framing fabric away from the block and carefully cut the framing fabric about 1/2in inside the machined stitchline as in Fig 26. Remove the cut square of framing fabric and save it to use another time – it is, after all, about 6 1/2in square, so you are saving a lot of fabric if you do this – your choice, as ever. Once this is done, follow step 4 to pin and stitch the outer corners in position on the block.

5 Press the outer edges of the block from the front of the work, avoiding the stitched windows, which do not need pressing. Finally trim the block down to 12 1/2in square on all sides. This will make a 12in finished block to be used in a project such as the cushion shown on page 19 or the quilt on page 24.

Framing the block – Style B

6 To make Style B as shown in Fig 27, place the block centrally on the right side of a square of framing fabric cut 13in square and pin it in place. To fix the main block securely to the framing fabric, quilt through the layers either by hand or machine as in Fig 28 – I use a hera marking tool to mark a guideline for the quilting. If you wish to cut away the framing fabric to save fabric (see the Tip above), cut the framing fabric about 1/2in inside the quilting lines.

7 Stitch each outer corner of the block firmly onto the framing fabric with several tiny stitches, following step 19 again on page 14.

8 The outer folded edges of the block are similar to the folded edges in the original Cathedral Windows and can be curved back and stitched in the same way. As there is no added window fabric to protect, the stitching is nice and easy, especially at the corners. Just follow steps 4-9 in Adding the Windows on pages 15-16 to pin and stitch the rolled-back curves. The shorter sides are rolled back in a curve to match the Cathedral Window curved edges, while the four longer outer edges should be rolled over in a deeper curve, about 1/2in at the centre. Start stitching at an inner corner and work all the way round the edges of the block, curving each seam as you reach it. Try to stitch through all the layers at intervals, especially on the longer curves, to fix the block securely to the framing fabric.

9 More quilting or decorative stitching by hand or machine could be added to the outer areas of the block if desired, especially if these are not lying very flat.

10 Press the framing fabric around the edges of the block and finally trim the block to 12 1/2in on all sides. This will make a 12in square finished block. This simple block can be used for stunning cushions as in the pair in the project shown on page 19. Even easier is the classic four square block adapted to make the carry cases on page 20, which can be used as a spectacle case or even a case for rotary cutters.



TECHNICAL TIP

The rolled-back curves could be top-stitched by machine if you prefer, especially if you machine-stitched the quilting that attached the block to the framing fabric earlier.

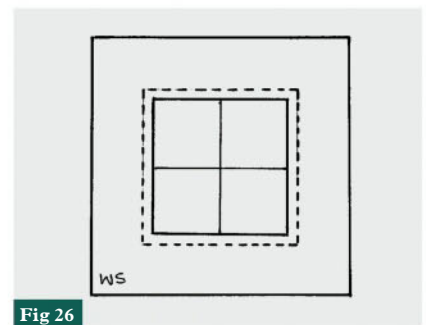

Fig 26

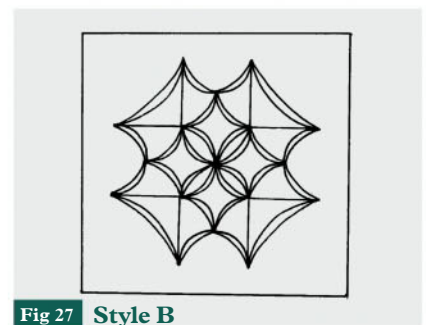

Fig 27 Style B

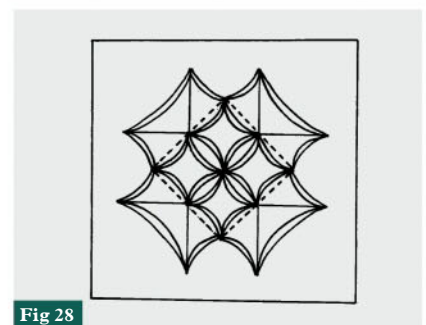

Fig 28

FOUR-SQUARE BLOCK PROJECT
CUSHION

PROJECT | *cushion*



You will need

- Contrast border – 12in x 17½in
- Backing fabric – Two (2) pieces 17½in x 12in
- 16in cushion pad

Finished size

- Approx. 17in square



"Consider using your favourite fabric for the folded squares, rather than for the four add-on windows, as you see more of it."

Make one of each framed block, or a matching pair for your favourite piece of furniture

5 Hem one long side of each backing piece by turning over a ½in twice and top stitching to secure.

6 Layer the cushion front, right side up, and two backing pieces right sides down, with the hemmed edges facing inward.

7 Stitch all around the four edges of the cushion. Clip the bulk from the corners and turn the cushion right way out, pushing out the corners with something tapered like a chopstick.

8 Flatten the edge of the cushion and pin together. Top stitch ¼in all around the edge of the cushion. Repeat with another line of top stitching ½in away from the edge.

9 Finally, insert your cushion pad to finish.



Cutting out

1 From the contrast border cut two (2) 3in x 12½in strips and two (2) 3in x 17½in strips.

Making the cushion

2 Make a four-square block as described in steps 1-19 on pages 10-14, and steps 1-9 on pages 15-16.

3 Choose a frame style and follow the instructions on pages 17-18 to frame the block.

4 Add the 3in x 12½in contrast borders to the sides and press seams out towards the borders. Attach the remaining borders to the top and bottom and press in the same way.

Make a single four-patch block to create a sweet little pouch useful for safekeeping all kinds of items

ONE-BLOCK PROJECT

LITTLE CARRYING CASES

This classy little carrying case has so many uses – head phones, spectacle, pen and pencil case, or a safe home for your rotary cutters – your choice.

It uses a combination of just two fabrics, so you can customise it as a gift by choosing those fabrics you know will please the recipient the most.





LITTLE CARRYING CASES



"This useful little carrying case will keep safe whatever you treasure. A great travelling companion."

Making the carry case

1 Take the four large cut squares of background fabric each 8in square and follow the instructions for making a four-square block starting on page 10, steps 1-19 to make the background squares and join them together ready for the windows.

2 Follow the instructions that follow on pages 15-16 for Adding the Windows, steps 1-9, to cut four (4) squares for the windows and pin and stitch them into place as described. The block should now have the four centre windows and the outer corners opened flat as in **Fig 1**, with the mid-points marked as shown.

3 Fold the bottom two corners in to the centre of the lower two blocks, folding at the marked mid-points as in **Fig 2**. Stitch the corners in place at

the centre of each block with two tiny stitches through all the layers as usual.

4 Top stitch by machine about $\frac{1}{8}$ in from the edges of the bottom triangle shapes through all the layers, or stitch by hand in small quilting stitches to hold the triangles in place (**Fig 3**).

5 At the top edge of the block, fold the right hand top corner to the centre of that folded square and stitch it in place at the centre with two tiny stitches through all the layers as usual. (**Fig 4**).

6 Top stitch this top triangle either by machine or quilt by hand as on the bottom edge about $\frac{1}{8}$ in from the edges as before (**Fig 5**).

You will need

- Main background fabric – four (4) 8in squares
- Fabric for the windows – six (6) $2\frac{3}{8}$ in squares
- Press stud for fastening
- Button as a decorative finish to the case

Finished size

- $7\frac{1}{2}$ in x $3\frac{3}{4}$ in

Notes

- Refer to instructions in "The New Technique" section throughout.

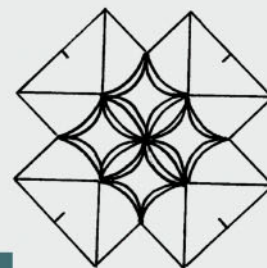

Fig 1

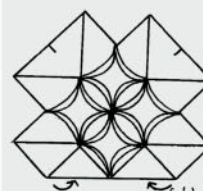

Fig 2

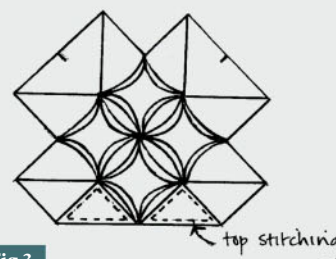

Fig 3

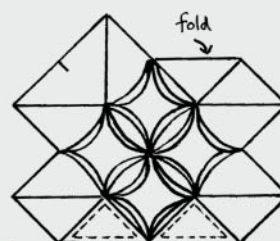

Fig 4



One-block project

The carrying cases are made from just one four-patch block as described in “The New Technique” section. Choose contrasting fabrics for the background and windows like Lynne’s indigo and cream block sample, right, to really show off the Cathedral Window.



7 Mark a stitching line from mid-point to mid-point along the right hand side of the block (**Fig 6**).

8 Fold the block in half from top to bottom with wrong sides together, matching the mid-point marks and the outer points of the block exactly (**Fig 7**).

9 Pin and stitch along the marked lines in the usual way to make a tall tube shape, which is just about big enough to get your hand inside (**Fig 8**).

10 Finger-press the four loose corners back from the stitched seam to the centre of each folded square and pin and stitch them in place (**Fig 9**).

11 Cut two (2) more squares of window fabric $2\frac{3}{8}$ in square to match the four already stitched in place on the block. Turn the fabric tube round to show the seam that has just been stitched. The background folded squares when joined into a tube create two small squares on-point at the centre as in **Fig 9**. This is where the two squares of window fabric are positioned (**Fig 10**). Start by pinning one window in place, then rolling the surrounding folded edges over it and stitching in place to create a Cathedral Window in the usual way. Repeat this to pin and stitch the second window in place on the tube.

12 Flatten the tube as shown in **Fig 11**, matching the joining seams. Stitch the bottom edges of the tube together firmly by hand – I use ladder stitch to do this.

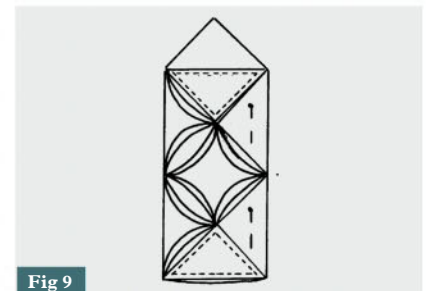

Fig 9

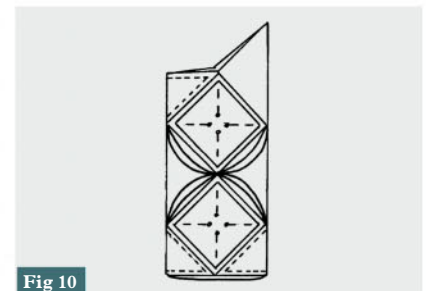

Fig 10

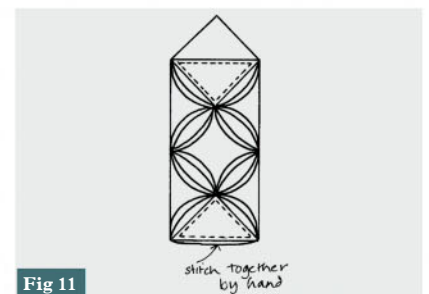

Fig 11

13 Fold the top flap over onto the front of the case and mark the position for the two parts of the press-stud, one on the front of the case and the other on the underside of the flap. Stitch these in place. Finally stitch a decorative button to the front of the flap to cover the stitches of the press-stud. I preferred to leave my cases without either a press-stud or button – I liked them as slip-cases. Your choice as to what seems good to you.

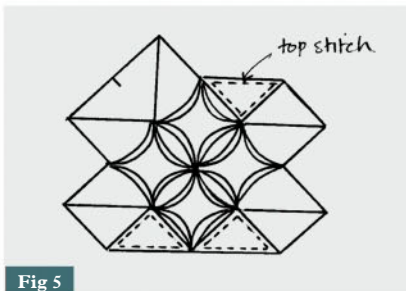

Fig 5

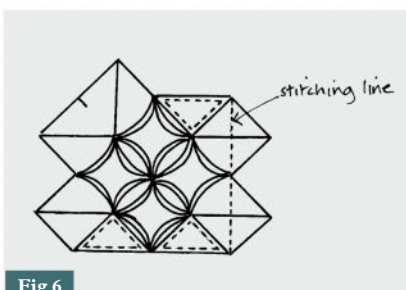

Fig 6

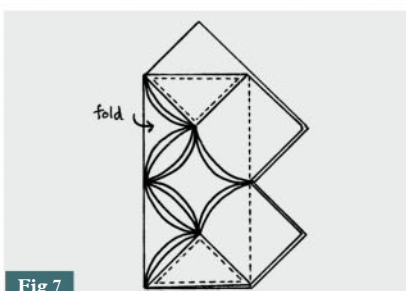

Fig 7

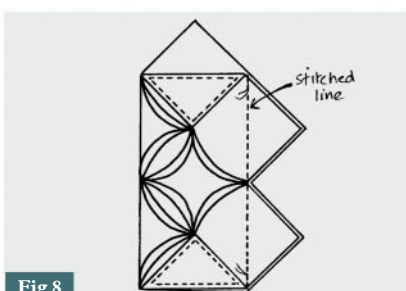

Fig 8

Calming white with
patterned fabric windows
make up this stunning quilt

ANY-SIZE QUILT PROJECT

EVERLASTING CATHEDRAL WINDOW

Making simple four-square Cathedral Window blocks can be totally addictive, especially without the extra step of adding borders, as my good friend Heather Jackson discovered in this everlasting quilt.





ANY-SIZE QUILT PROJECT EVERLASTING CATHEDRAL QUILT



"This design pays homage to the traditional look of Cathedral Window, while adding quiet calm through the white background fabric."

Everlasting Cathedral Window

In the quilt featured, Heather Jackson used plain white fabric for all the folded squares, and fussy-cut windows from some of her favourite fabrics to make a series of classic four-square blocks as in **Fig 1**. She began with a plan to make just four of these blocks which, she would join together as a small hanging or quilt. However, by this time, the addiction had taken hold, so Heather, the hapless victim, immediately embarked on more blocks in the same arrangement of white plus assorted scraps fussy-cut for the windows. At the time of writing the

pattern, the quilt had sixteen (16) blocks arranged in four (4) rows each of four (4) blocks, but the outer edges were left opened out as points, so the quilt could be enlarged by adding more blocks at any time if she wanted to. And indeed she did, as it has since

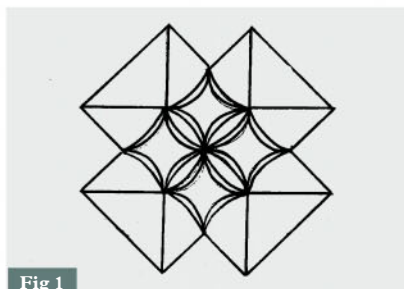

Fig 1

You will need

- White fabric for Four-Square blocks (sixty-four (64) folded squares) – 3yds
- Fabric for windows – Sixteen (16) pieces of assorted fabrics, each 6in square or ½yd in total

Finished size

- 33¾in square (or as large as you like)

grown to twenty-five (25) blocks and she still has quite a lot of potential window fabric waiting to be used, and more plain white fabric could always be purchased, so this really could be an everlasting, add-on project...

Instead of adding windows over the entire design as in so many traditional Cathedral Window quilts, the design is enhanced by leaving the final joining seams between the four-square blocks free from overlying windows, which gives the design a quiet calmness. These areas combine at the junctions of the blocks to make a larger white space, with the curved-back edges and the joining seams becoming a feature.

The joy of this project is that it can be any size that the maker wants and any shape – square or rectangular. Each four-square block measures approximately 7½in square plus an extra 1⅛in on all sides created by the edging points that give the quilt its distinctive finish. To calculate the number of blocks for larger bed-sized projects, work in units of 7½in and add an extra 3¾in in total for the edging points. Alternatively, you could simply keep adding rows of blocks, try it on the bed and when it looks good say, "That'll do nicely," and stop. One of the main attractions of traditional Cathedral Window quilts was that once the folded squares were joined and all the windows added, the quilt was finished – no layering with batting and backing fabric, no quilting! And this everlasting repeat block works in just the same way.

A very different effect can be achieved by changing not only the

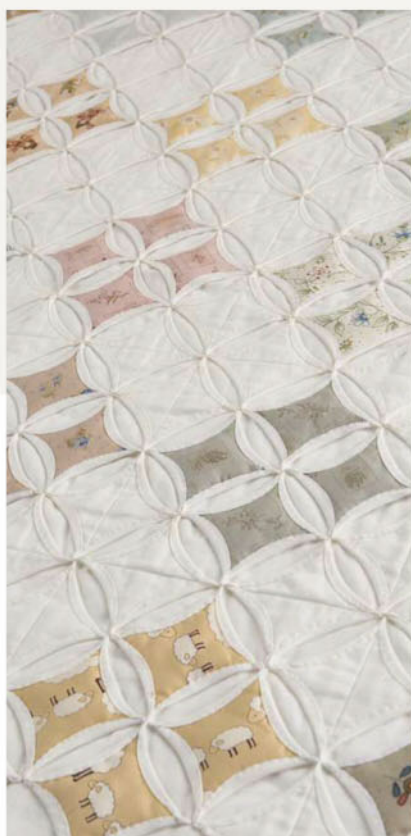

groups of windows but also the background folded fabric from block to block, there are no limits to the creative variations you can do!

Making the blocks

1 To make one four-square block follow the instructions given in Making a Four-Square Block starting on page 10, using four (4) squares of white fabric each cut 8in square for the folded squares, and one of the chosen 6in squares to make the four windows on that block.

2 Repeat this whole process to make sixteen (16) blocks in total. Each block uses a different fabric for the four windows.

Joining the blocks

The quilt is made in four units, each of four blocks, which are finally joined together to complete the design.

3 Arrange four blocks in two rows each of two blocks (**Fig 2**). Take the top row of two blocks and mark a stitching line from mid-point to mid-point across the right hand edge of one block only (**Fig 3**).

Scrappy blocks

Wendy Jobber's blocks demonstrate how different combinations of fabrics could create quite varied effects in this quilt. Change the background fabric, centre fabrics or both with every block, to create more of a scrappy effect.

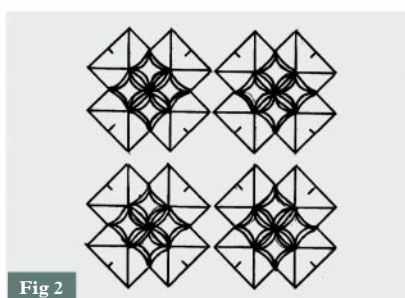

Fig 2

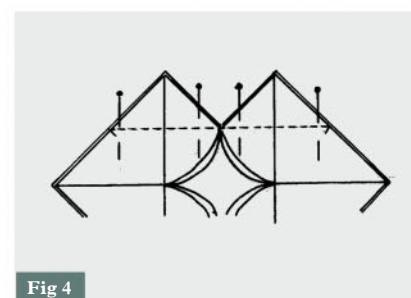

Fig 4

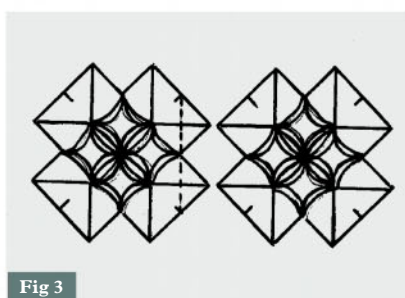

Fig 3

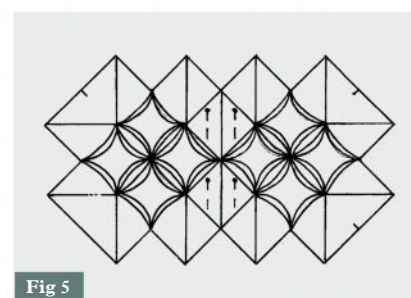

Fig 5

4 Place the two blocks together with the unmarked sides facing and the marked stitching lines on the top layer. Match the mid-point marks exactly at either end of the marked stitching lines and pin in place, and also at the centre junction, pinning either side as in **Fig 4**. Add more pins to fix the two layers exactly on top of each other and stitch across the matched mid-point marks from one end of the pinned squares to the other. Start and finish $\frac{1}{2}$ in from the ends as usual.



5 Press the loose corners of the stitched seam towards each block and pin in place (**Fig 5**). Stitch the corners firmly in position in the usual way.

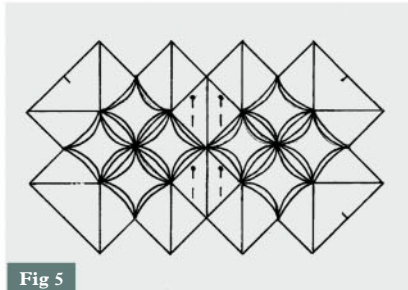

Fig 5

6 Repeat steps 4-5 with the bottom row of two blocks.

7 Place the two rows of blocks back in the original arrangement as in **Fig 2**. Mark a stitching line from mid-point to mid-point across one row of blocks only (**Fig 6**).

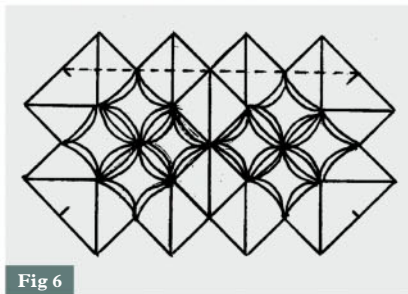

Fig 6

8 Place the two rows of blocks together with the unmarked sides facing and the marked stitching lines on the top layer as in step 4 above. Match the mid-point marks and junctions exactly at either end of the marked stitching lines and pin in place as described in step 4. Stitch as before, stitching across the matched mid-point marks from one end of the pinned squares to the other.

9 Open out the blocks and press the eight loose corners of the folded white fabric back from the seam and pin in place (**Fig 7**). Stitch the corners firmly in position in the usual way.

10 Roll back and stitch all the folded edges of white fabric where the four blocks were joined together in the usual Cathedral Window method, but without adding

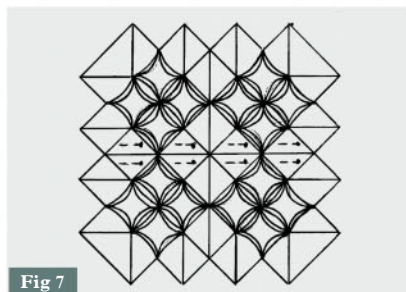

Fig 7

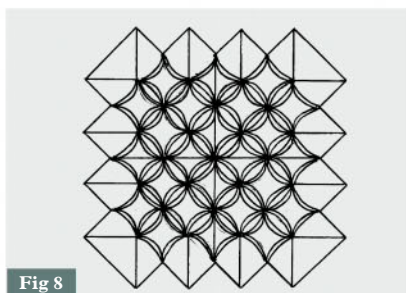
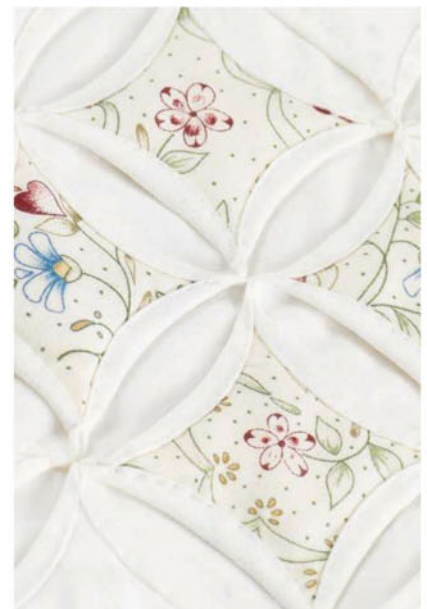

Fig 8



TO

TECHNICAL TIP

If you run out of the fabric for the background folded squares, you could introduce a similar or sympathetic fabric for the new blocks and place them in the overall design so that they add to the richness of the background and combine with the original blocks in a pleasing way.

any squares of window fabric, as shown in **Fig 8**. The joining seams will still be visible running across the window area, which adds interest to the design.

11 Repeat this process from steps 3-10 three more times to make all four (4) quarters of the design.

12 Arrange the four quarter-sections of the quilt in two rows each of two sections. Take the top row of two (2) sections and mark a stitching line from mid-point to mid-point across the four folded squares on the right hand edge of one section only. Follow step 8 previously to join the two sections together.



Heather fussy-cut her favourite fabrics for the windows of the quilt



In the everlasting quilt, blocks can be added in rows to grow it with time. After Lynne wrote the instructions, Heather added a row to the side and bottom. What was once planned for a wall decoration is growing into something much larger – these blocks are addictive!

13 Press the eight loose corners of the stitched seam back from the seam and pin in place. Stitch the corners firmly in position in the usual way.

14 Join the bottom row of two sections together in the same way.

15 Finally use the same technique to join the two halves of the design together. Press each of the 16 loose corners back from the long

joining seam and pin them in place as before. Stitch the corners firmly in position in the usual way.

16 Roll back the folded edges of white fabric where the four sections of the quilt were joined together and stitch the curves without adding any squares of window fabric to complete the design. Continue to add blocks in rows as you wish. The outer points are left around the edge of the quilt to create an unusual and attractive finish to the piece.

A green, gold and red colour scheme makes this the perfect centrepiece for your Christmas table

DECORATIVE CENTREPIECE

CHRISTMAS TABLERUNNER

This elegant table runner is made really effective by using a gold striped cotton fabric for the main folded shapes. The stripes change direction when the bias edges are curved, giving an intriguingly complex surround to the red windows. Placing the central design on the dark green background with its final gold striped edging makes for a stunning centerpiece on the Christmas table.





DECORATIVE CENTREPIECE
**CHRISTMAS
 TABLERUNNER**



"The star of this table runner is the gold striped fabric! It changes direction as it is folded, adding impact to the finished design."

You will need

- Fabric for the folded squares plus the outer border frame – $\frac{3}{4}$ yd
- Fabric for the windows – Two (2) fabrics: One (1) piece 6in square for the centre four windows, one (1) piece about 12in x 8in for the surrounding twelve (12) windows.
- Background fabric for the front of the runner – 34in x 14in
- Fabric for the back of the runner – 36in x 15in
- Batting (wadding) – 35in x 15in

Finished size

- 33½in x 14½in

Joining the folded squares

The design is made from two rows of folded squares, with six (6) folded squares in the top row and six (6) folded squares in the bottom row. The stitching lines for joining the squares need to be marked with a temporary marking pencil. Only the top layer needs to be marked as a guide for the stitching.

3 Arrange the top row of six (6) folded squares as shown in **Fig 1**. Take care to position the unstitched gaps in the positions as shown, A-E facing the right, F facing the left.

4 Join the marked mid-points across the unstitched gap of the folded square marked (A) with a fine

Before you start

The design seems deceptively complicated, but is in fact just the original four-square block repeated three times and then joined together, with extra windows added at those joining seams. I have also tackled the problem of trying to bind the edges of a quilt that has corners that are not a straightforward 90-degree right angle. Regular binding is a nightmare to get looking good, so I have avoided that by adding a final border of my striped gold fabric that will finish just ½in

wide, looking just like binding around the edges of the runner.

Making the table runner

1 From the fabric chosen for the base folded squares (I used gold striped cotton fabric), cut twelve (12) 8in squares.

2 Follow the instructions given in **Making a Four-Square Block** starting on page 10, steps 1-19 to make twelve (12) folded squares ready to join together.

TQ

TECHNICAL TIP

It is important that block (F) at the end of the row is turned with the unstitched gap towards block (E) as shown in **Fig 1**. The rest are all with the gap at the right hand side of the folded square.

Tying Simple Knots

The basic method is to hand sew a thread through all layers of the quilt, tie it in a reef knot and then trim the ends. The knots can be tied from front to back of the work, or vice versa.

1 Pencil mark the place where you want the knot to be. Prepare a needle and thread. A thread length of 7in-10in is a comfortable one to tie and make bows with. Pass the thread through the layers of the quilt, from the back through to the front (or vice versa). Return again to the back, spacing the stitches about $\frac{1}{8}$ in apart (**Fig 1A**). You can do this twice or more if desired. Both thread ends should end up at the back (or front) of the work.

2 Pull the thread ends snug against the work and make a reef knot – right over left and then left over right (**Fig 1B**). Tie the knot tightly and trim the thread ends or leave them a little long if you prefer.

For more instructions by Linda Clements on tying quilts, see the *Essential Guide* in issue 15

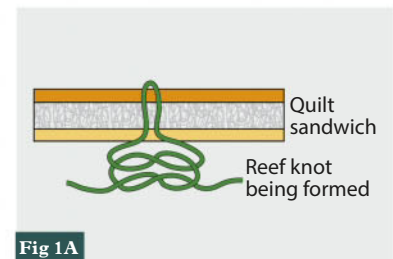

Fig 1A

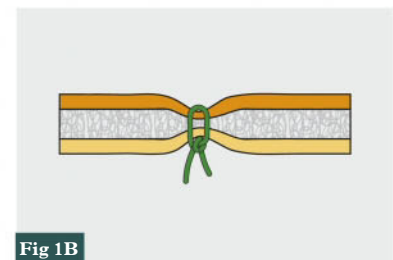

Fig 1B

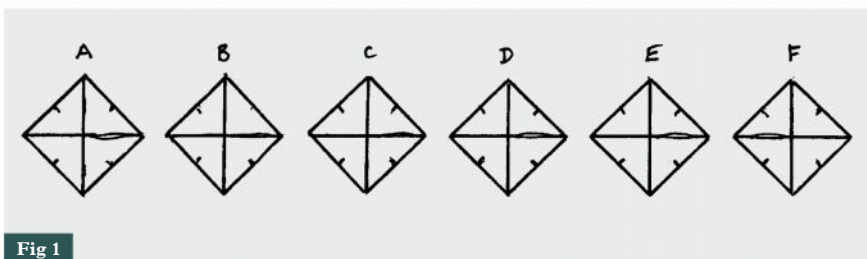

Fig 1

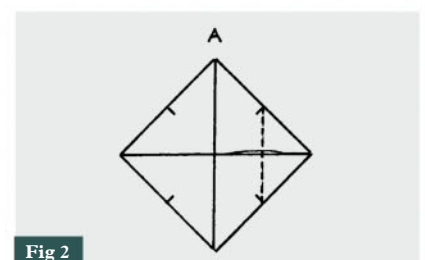

Fig 2

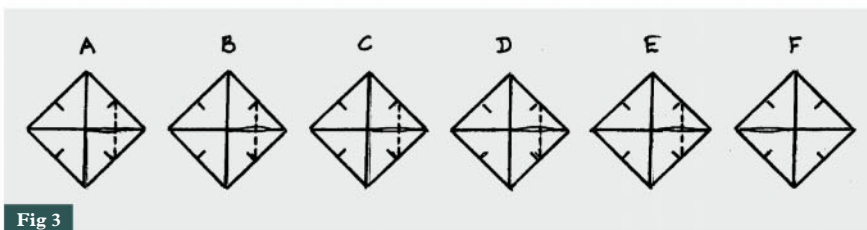

Fig 3

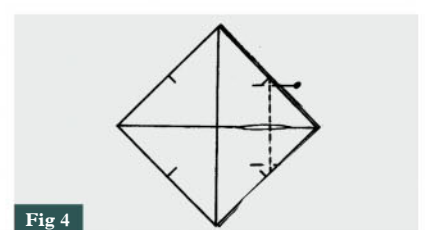

Fig 4

temporary marking pencil, keeping the marking as light as possible, especially at the ends, where the marks may show slightly when the edges are rolled back and stitched later (**Fig 2**).

5 Repeat this on squares (B), (C), (D) and (E), each time marking across the unstitched gap. Leave the folded square (F) unmarked. Place the blocks back in the design as shown in **Fig 3**.

6 Pick up the two squares (A) and (B) together as they have been arranged in the row, with block (A) uppermost. Match exactly the marked mid-line points at either end of the stitching line on the top square (A) with the marked mid-points on the underneath square (B) and pin

together (**Fig 4**). Pin through all layers in two more places along the stitching line, making sure that the edges of the unstitched sections on each square are closely butted together.

7 Follow step 14 in *Joining the Folded Squares* on page 13 to stitch square A to square B.

8 Repeat steps 6 and 7 above to stitch square (C) to square (B). Place the joined unit of three folded squares back in the design and check that the unstitched gaps are still in the right position.

9 Repeat this process to join first block (D) to block (C) and then to join block (E) to block (D). Finally join the last block (F) to block (E).

Place the joined unit back and check that all the seams and unstitched gaps are in the right place (see **Fig 3** to check this).

10 Press the corners of the stitched seams to the centre of each square and pin in place (**Fig 5**).

11 Take the remaining six (6) folded squares and follow steps 3-10 to make the second row of the design.

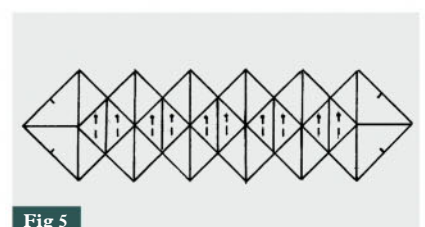

Fig 5

12 Mark a stitching line from mid-point to mid-point across the top row of squares (**Fig 6A**).

13 Arrange the two rows of the design as in **Fig 6B**.

14 Place the two rows together with the unmarked sides facing and the marked stitching lines on the top layer. Match the mid-point marks exactly at either end of the marked stitching lines and pin in place, and also at the centre junctions, pinning either side as in **Fig 7**. Add more pins to fix the two layers exactly on top of each other and stitch as before, stitching across the matched mid-point marks from one end of the pinned squares to the other. Start and finish $\frac{1}{2}$ in from the ends as before. The aim is to make a perfect match of the folded edges at either end of the stitching and at the junctions of the seams of the rows of folded squares.

15 Press each of the loose corners that are in the middle area of the block to the centre of each folded square, leaving just the outer 16 corners untouched (**Fig 8**). Stitch each corner onto the exact centre of each square with two small stitches through all the layers. Pull the stitches really firmly and finish off at the back with two tiny stitches through the back layer only.

Adding the windows

I used two different red fabrics for the windows – a patterned fabric was used for the four centre squares and the remainder in a plain red fabric (see page 31).

16 From the first fabric cut four (4) squares each $2\frac{3}{8}$ in square. From the second fabric cut twelve (12) squares each also $2\frac{3}{8}$ in square.

17 Follow the instructions given in Making a Four-Square Block – Adding the Windows on page 15 to pin and stitch the 16 windows in place on the folded squares.

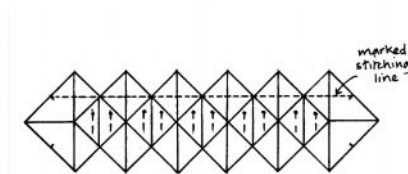

Fig 6A

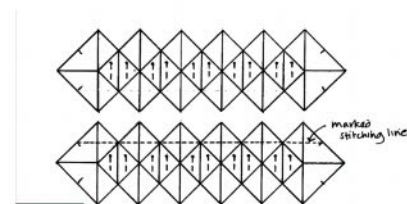

Fig 6B

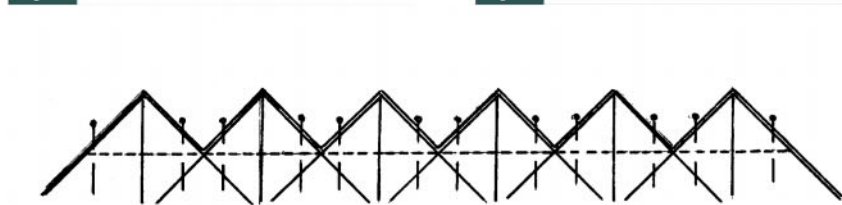

Fig 7

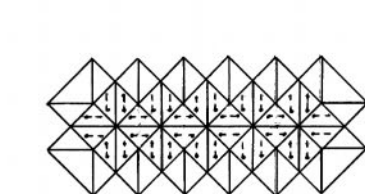

Fig 8

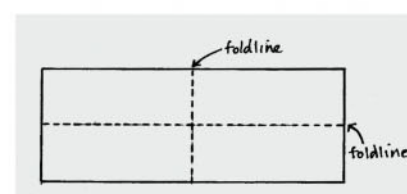

Fig 9

Assembling the tablerunner top

18 From the fabric chosen for the background of the design (mine was the dark green) cut a piece 34in x 14in. Fold this rectangle in half and press it lightly. Unfold, and refold it in half in the other direction. Press lightly and then open the fabric out again (**Fig 9**). These two fold lines help position the Cathedral Window unit centrally on the background fabric.

19 Place the Cathedral Window design centrally on the right side of the rectangle of background fabric and pin it in place. To fix the main block securely to the background fabric, tie the quilt through the layers at each junction of

the Cathedral Window blocks, tying from the back of the work so that the tiny stitches are barely visible (see box on page 33).

20 Stitch each outer corner of the block firmly onto the framing fabric with several tiny stitches, finishing off at the back as in step 15 previously.

21 The outer folded edges of the block are similar to the folded edges in the original Cathedral Window and can be curved back and stitched in the same way. As there is no added window fabric to protect, the stitching is nice and easy, especially at the corners. Just follow steps 4-9 in Adding the Windows on pages 15-16 to pin and stitch the rolled-back curves. The shorter sides are rolled back in a curve to match the Cathedral Window curved edges, while the two longer edges at either end of the design should be rolled over in a deeper curve, about $\frac{1}{2}$ in at the centre. Start stitching at an inner corner and work all the way round the edges of the block, curving each seam as you reach it. Try to stitch through all the layers at intervals, especially on the longer curves, to fix the block securely to the framing fabric.



22 To make the pointed ends, mark the centre of each short end of the fabric and 7in away from each corner as shown in **Fig 10A**. Join up the marks with a drawn line as in **Fig 10B** and cut along the drawn lines to remove the corners (**Fig 10C**).

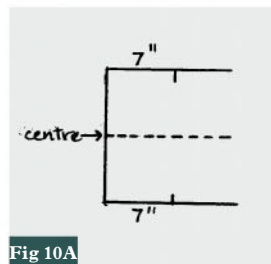

Fig 10A

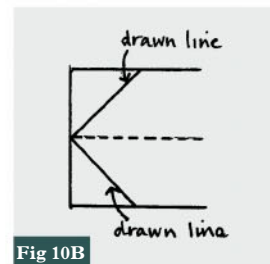

Fig 10B

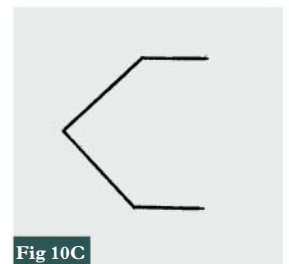

Fig 10C

Adding the narrow border strips

23 From the border fabric cut two (2) strips each measuring 1in x 23in. Pin and stitch them to either side of the background strip (**Fig 11A**) – they should be slightly longer than the edges of the runner. Press the seams outwards, away from the background fabric, and trim the corners to match the angle of the pointed ends of the runner (**Fig 11B**).

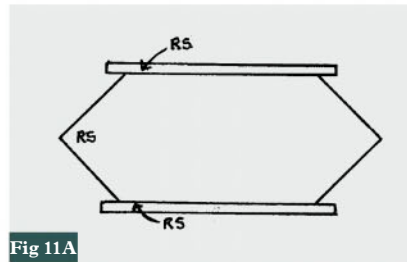

Fig 11A

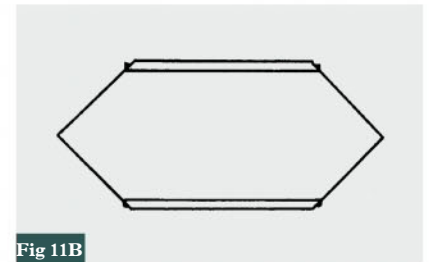

Fig 11B

24 From the border fabric cut four (4) strips each measuring 1in x 11in. Take one of these strips and pin and stitch it to one end of the runner (**Fig 12A**), matching the square corner of the runner with one end of the border strip. Press the seam outwards, away from the runner.

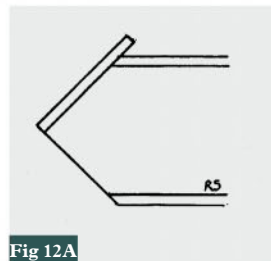

Fig 12A

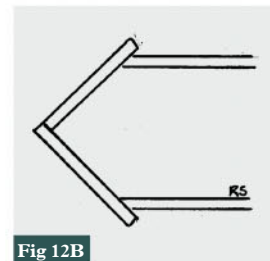

Fig 12B

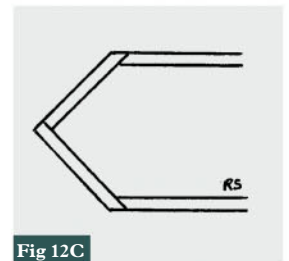

Fig 12C

25 Pin and stitch a cut strip to the other raw edge of the runner (**Fig 12B**), matching the square corner of the runner with one end of the border strip. Press the seam outwards as before.

26 Trim the long ends of the border strips to match the sides of the runner (**Fig 12C**).

27 Repeat steps 24 and 25 to pin and stitch the remaining two cut strips of border fabric to the other end of the runner. Trim the ends to match the runner as before (**Fig 12C**).

Quilting and finishing

28 Cut the backing fabric chosen for the runner into two (2) pieces, each 15in x 18in. Stitch them together lengthways, leaving a section about 6in long in the centre unstitched (**Fig 13A**). Press the

seam open, including the unstitched section (**Fig 13B**).

29 Trim the backing and the cut piece of wadding (see You Will Need list on page 32) to fit exactly the front of the runner. Layer the three pieces in this order: first the wadding, then the front of the runner onto it with right side up, and then the backing fabric, right side down, matching all the edges exactly. Pin the layers together around the edges.

30 Using the walking foot, stitch a $\frac{1}{4}$ in seam around all the edges. Trim the corners a little to reduce the bulk and turn the runner through to its right side through the unstitched section of the backing fabric. Press the edges of the runner and stitch the gap in the backing fabric closed before tying at the junctions of the windows (if you have not already done that). I also machined along the seam (known as stitching in the ditch) between the background fabric and the final narrow border to hold everything in place.

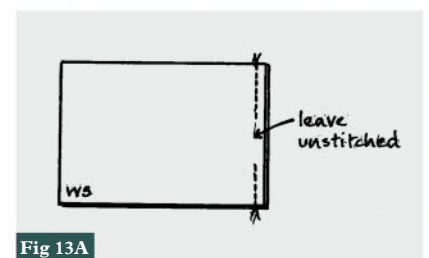

Fig 13A

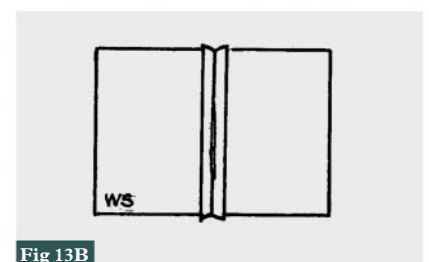

Fig 13B

Take the technique one step further with Lynne's beguiling nine-patch block

NINE-SQUARE BLOCK

WINDOWS WALL HANGING

Once you have explored the many designs that can be made just by using four folded squares with the added windows, you may like to think bigger!

This wall hanging uses nine folded squares as the base layer, with two fabrics making the overlying windows.

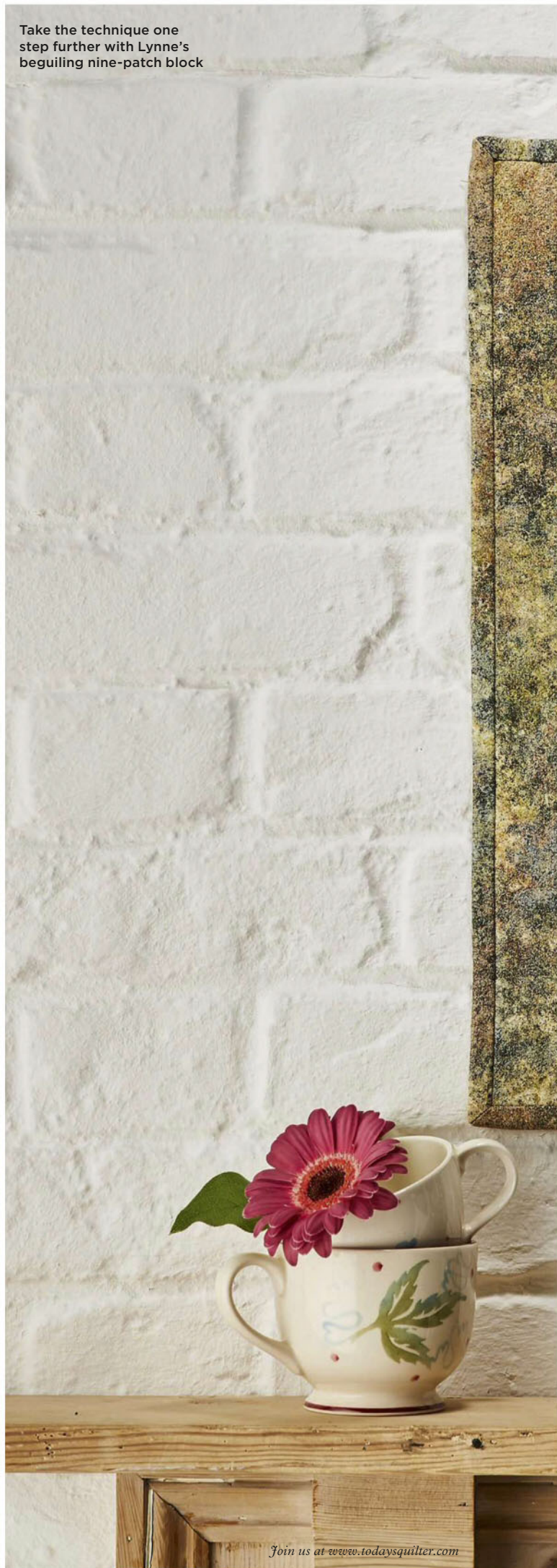
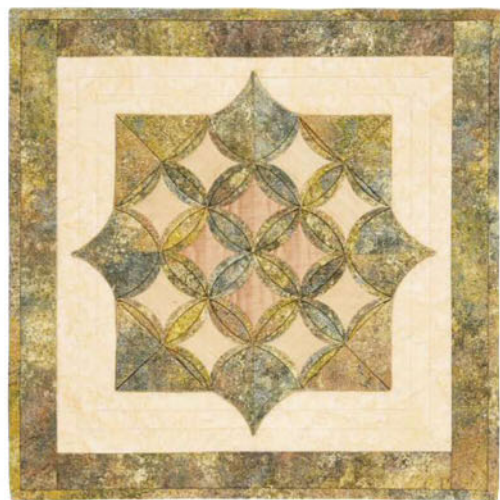



NINE-PATCH BLOCK
WINDOWS WALL HANGING



"I chose a textured fabric for the folded squares with two shades of Dupion silk fabric for the windows."

You will need

- Fabric for the folded squares plus the outer border frame and binding – 1yd
- Fabric for the overlying windows – two (2) fabrics, one (1) piece 6in square from which will be cut the centre four windows, one (1) piece 12in x 6in for the surrounding eight (8) windows.
- Background fabric for the gold bordering frame – 17in square
- Batting (wadding) – 21in square
- Backing fabric – 21in square
- Hanging sleeve fabric 3in x 20in (optional)
- Baton– 19in long (optional)

Finished size

- 20in square

unstitched sections on each square are closely butted together.

5 Follow step 14 in Joining the Folded Squares on page 13 to stitch square A to square B.

6 Repeat this process to stitch square C to square B, making the top row of three squares. Press the corners of the stitched seams to the centre of each square and pin in place (**Fig 4**).

Making the folded squares

1 From the fabric chosen for the base folded squares, cut nine (9) 8in squares.

2 Follow the instructions given in Making a Four-Square Block on page 10, steps 1-11 to make nine (9) folded squares ready to join together.

Joining the folded squares

The stitching lines for joining the squares need to be marked with a temporary marking pencil. Only the top layer needs to be marked.

3 Join the marked mid-points across the unstitched gap of one folded square (A) with a fine temporary marking pencil, keeping the marking as light as possible, especially at the

ends, where the marks may show slightly when the edges are rolled back and stitched later (**Fig 1**). Repeat this with a second folded square (B).

4 Arrange the two marked fabric squares (A and B) in a row with one unmarked square (C), each with the unstitched sections positioned as in **Fig 2** (A facing the right, B and C facing the left). These will be stitched together along the marked lines. Place the two squares A and B together with the unstitched gaps facing and the two unstitched gaps positioned on top of each other. Match exactly the marked mid-line points at either end of the stitching line on the top square with the marked mid-points on the underneath square and pin together (**Fig 3**). Pin through all layers in two more places along the stitching line, making sure that the edges of the

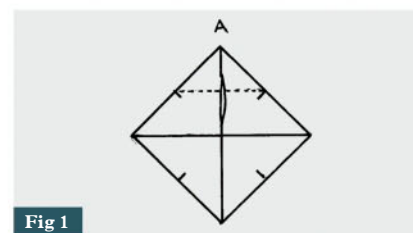

Fig 1

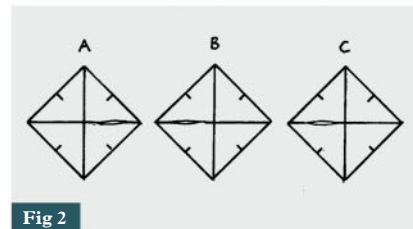

Fig 2

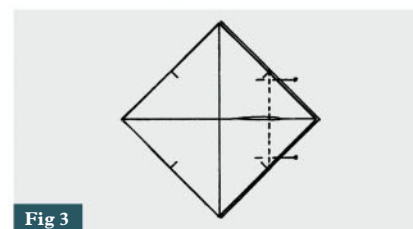

Fig 3

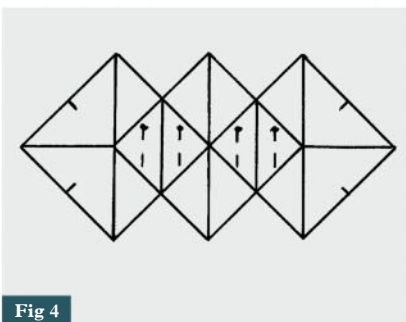

Fig 4

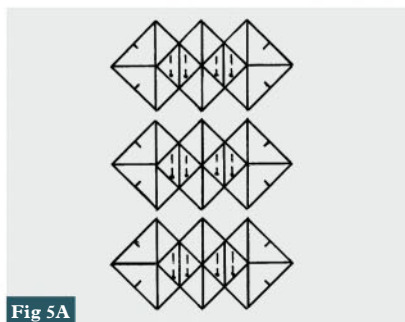

Fig 5A

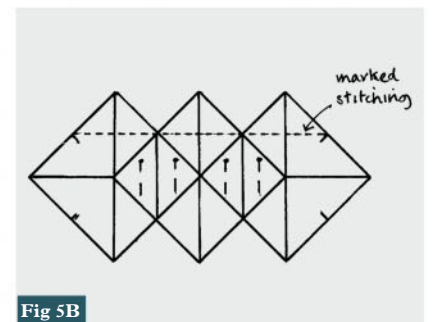

Fig 5B

7 Take three (3) of the remaining folded squares and repeat steps 3-6 previously to join the squares together to make row two of the block.

8 Take the final three (3) folded squares and join them together in the same way to make row three of the block.

9 Arrange the three rows of the design as in **Fig 5A**. Mark a stitching line from mid-point to mid-point across row one only (**Fig 5B**).

10 Place the top two rows together with the unmarked sides facing and the marked stitching lines on the top layer as in step 4 previously. Match the mid-point marks exactly at either end of the marked stitching lines and pin in place, and also at the centre junctions, pinning either side as in **Fig 6**. Add more pins to fix the

two layers exactly on top of each other and stitch as before, stitching across the matched mid-point marks from one end of the pinned squares to the other. Start and finish $\frac{1}{2}$ in from the ends as described previously. The aim is to make a perfect match of the folded edges at either end of the stitching and at the junctions of the seams of the rows of folded squares.

11 Repeat this to join the third row to the second row to complete the block.

12 Press each of the loose corners that are in the middle area of the block to the centre of each folded square and pin them in place, leaving the outer corners untouched (**Fig 7**). Stitch each of these pressed corners onto the exact centre of each square with two small stitches through all the layers. Pull the stitches really firmly

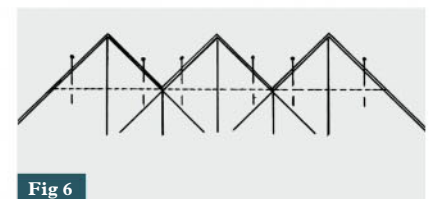

Fig 6

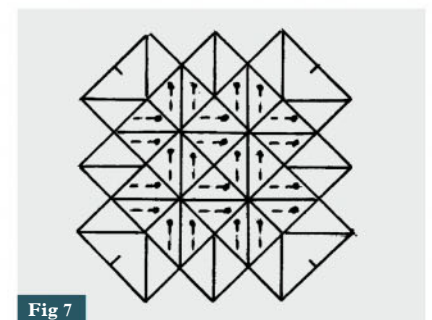

Fig 7

and finish off at the back with two tiny stitches through the back layer only. Run the needle into the back layer for about 1in before cutting off the thread to keep the back looking neat.

Adding the windows

13 From the fabric chosen for the centre of the design cut four (4) windows each $2\frac{3}{8}$ in square. From the fabric chosen for the surrounding windows cut eight (8) squares also $2\frac{3}{8}$ in square.

14 Place the four centre windows in position on the joined folded squares as in **Fig 8A**. Place the eight other windows in position around them as in **Fig 8B**.

15 Working from the centre, pin and stitch each window in the usual way (**Fig 9**).

Framing the Cathedral Window block

16 Take the Cathedral Window block and mark the outer stitching lines at each corner with a temporary fabric marker from mid-point to mid-point (**Fig 10**) in the usual way. Note that the folded square in the middle of each side of the block does not have a marked stitching line.

17 Place the block centrally on the right side of the cut square of framing border fabric (cut 17in square) and pin it in place along the marked lines as in **Fig 11**.

18 Stitch along the marked lines at each corner in the usual way.

19 Press the eight outer corners in to the centres of the folded squares and pin in place. Stitch each corner onto the block, stitching firmly through all the layers as usual (**Fig 12**).

20 The four (4) remaining outer points on the Cathedral Window block need to be stitched onto the background framing fabric. Stitch each corner of the block down firmly with several tiny stitches, following step 19 in Making a Four-Square Block on page 14.

21 The two folded edges of these points on the block are similar to the folded edges in the original Cathedral Windows and can be



Fig 8A

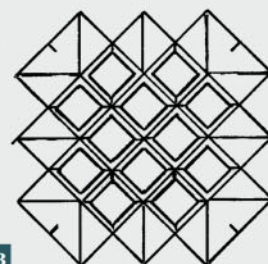

Fig 8B

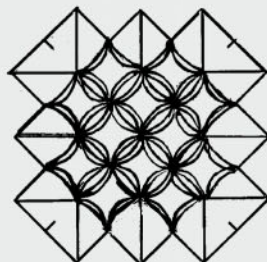

Fig 9

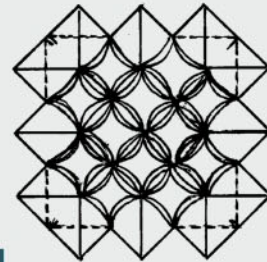

Fig 10

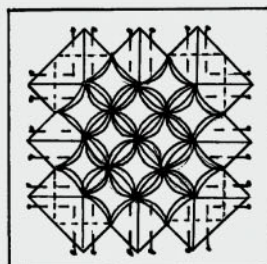

Fig 11

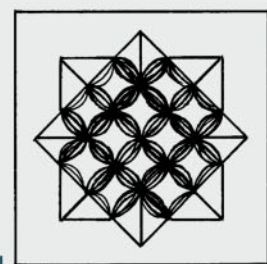

Fig 12

Thrifty stitching

I like to leave the Cathedral Window block supported by the square of framing fabric, as it gives it stability, but if this seems a shocking waste of your precious fabric, before stitching the eight outer corners into place at the centre, remove the pins and turn the work to the back. Pull the framing fabric away from the block and carefully cut the framing fabric about $\frac{1}{2}$ in inside the machined stitchline as in **Fig 13**. Remove the cut square of framing fabric and save it to use another time – it is, after all, about 10in square,

so you are saving a lot of fabric if you do this – your choice, as ever. Once this is done, pin and stitch the outer corners in position on the block.

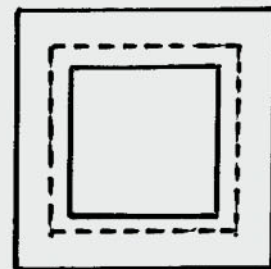

Fig 13

curved back and stitched in the same way. As there is no added window fabric to protect, the stitching is nice and easy, especially at the corners. Just follow steps 4-9 in Adding the Windows on pages 15-16 to pin and stitch the rolled-back curves to match the Cathedral Window curved edges (Fig 14). Try to stitch through all the layers at intervals to fix the block securely to the framing fabric.

22 Press the framing fabric around the edges of the block and trim the block to 16½in square.

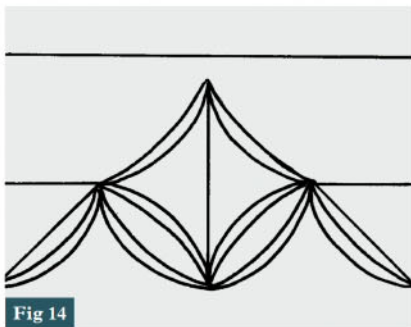

Fig 14

Adding the final border

23 From the fabric used for the Cathedral Window block, cut two (2) strips each 2½in x 16½in. Pin and stitch these to either side of the block. Press the seams from the front away from the block.

24 From the same fabric cut two (2) strips each 2½in x 20½in. Pin and stitch these to the top and bottom of the block. Press the seams away from the block as before.

Quilting and finishing

25 Layer the backing fabric, batting and quilt top and baste. Quilt or tie the quilt if desired.

26 Trim the backing and batting square. From the binding fabric cut three (3) 2½in x WOF strips. Stitch binding strips into one continuous length and use to bind the wall hanging.

27 To make a hanging sleeve for a baton, cut a piece 3in x 20in. Hem the short sides by turning over a ¼in -½in seam and top stitching to secure. Repeat with the long sides. Slip stitch the sleeve along the two long sides to the wrong side of your wall hanging, at the top below the binding.



Japanese Windows

“This is my most recent piece using Cathedral Window, where I have been exploring the possibilities of using this new method of making the blocks. I love everything Japanese, and this technique is of course very origami-like, so I worked with a group of fabrics that reflected all this. Rather than make this a detailed step-by-step project, I thought it might be good to give a general outline of the way it was made, so it might give those wanting to explore this technique with designs of their own some ideas for how to do it. After some preliminary drawings to establish a working idea for the design, I made a base layer of folded squares using two shades of putty coloured fabrics plus four folded squares using indigo coloured fabric. I stitched them together in the usual way and sewed down all the corner flaps except those on the outer edges, ready for windows to be added.

“The whole design was then placed on-point on a large square of indigo fabric, and the outer corners played with until I decided on the arrangement shown in the picture of the finished quilt. Some were left as triangles extending out onto the background fabric, others folded back in place in the folded squares. Because the main design is formal and symmetrically balanced, I deliberately made the edges asymmetrical, just to add an unexpected twist at it all.”



LIBRARY ESSENTIALS

Find tips, patterns, ideas and inspiration for everything from creating gorgeous quilts to using up fabrics in your stash with these books by Lynne Edwards MBE

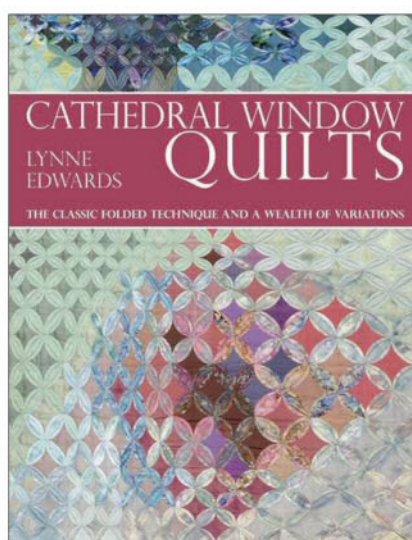

Cathedral Window Quilts
With over 25 flamboyantly-folded projects ranging from heirloom quilts and striking wall hangings to colourful quick-to-make cushions, bags and pincushions. Clear step-by-step instructions, handy machine shortcuts and Lynne's uniquely creative approach will capture your imagination and inspire you to master these classic techniques.
Published by David & Charles, £14.99
www.lynneedwardsquilts.com

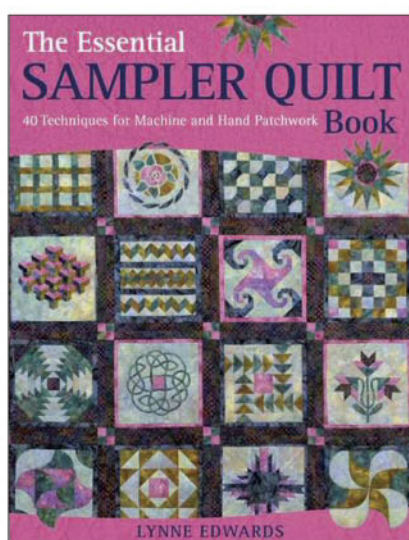

The Essential Sampler Quilt Book
Master a range of patchwork and quilting techniques while sewing classic block designs, such as Mariner's Compass, Rail Fence, Celtic Knot, Attic Windows, Tumbling Blocks, Drunkard's Path and Courthouse Steps. Colour illustrations guide you through each step, making even the most complicated techniques easy to follow.
Published by David & Charles, £19.99
www.lynneedwardsquilts.com



Quilt Essentials: 9 Classic Quilt Blocks
With step-by-step instructions for creating nine classic quilting blocks, the book includes techniques for finishing, quilting and turning them into a quilt or wall hanging. A great introduction to quilt block piecing.
Published by David & Charles, £6.99
www.lynneedwardsquilts.com



Creating Waves
In this booklet Lynne has designed five lovely projects using both the Non-Slip 2in and 3in Wavy Border Rulers from Creative Grids. Her clear and concise approach to instructions guides you through each process with tips along the way.
£12.99 www.creativegrids.com,
www.lynneedwardsquilts.com



Blanket Stitch Quilts
Learn to sew beautiful handmade quilts with Lynne Edwards' simple blanket stitch appliqué technique. Straightforward instructions allow even new quilters to create gorgeous quilts and experienced quilters will love adopting the stick-and-stitch technique that gives such great results for more complicated designs. Detailed step-by-step instructions with full-colour illustrations.
Published by David & Charles, £19.99
www.lynneedwardsquilts.com

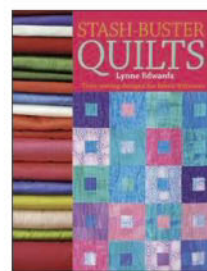

Stash-Buster Quilts
The book provides solutions for the quilters' biggest problem, designs that can use up their fabric hoard or stash. Featuring 14 exciting new patchwork projects, including projects for creating bags, cushions and soft toys, all perfect for using up fabric scraps.
Published by David & Charles, £16.99
www.lynneedwardsquilts.com





“I want quilters to love Cathedral Window, so I needed to make it as easy as possible for them to achieve without compromising the technique in any way.”

Lynne Edwards MBE